

Multifunktional
self-driven lifting device

SL 580 Maxi

Indoor lift for heavy windows and panes

Lifts and handles elements up to 580 kg

The SL 580 Maxi is an agile and stable lifting device – excellent for easy lifting and moving of the heaviest window panes and sheets of glass.



The lifting capacity and precise movements of the Smartlift make the machine ideal for installation of e.g. heavy fire doors.

- Two vacuum circuits with two pumps
- Handy og compact
- Multifunktional
- Self-propelled
- Accurate to the millimeter
- Labour-saving
- Improves work environment
- Tried-and-tested Danish quality



The SL 580 Maxi is increasingly used in industry for heavy lifting jobs.

Windows are kept securely in place throughout the installation process.



N.A. Christensensvej 39
DK-7900 Nykøbing Mors
Tlf.: +45 97 72 29 11
E-mail: smart@smartlift.dk
www.smartlift.dk





The lifting device has a multifunctional swivel head.



The SL 380 can be shifted sideways up to 100 mm for precision adjustment during the window installation process.

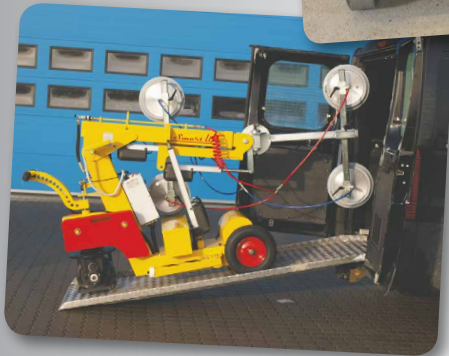

The Smartlift is easily transported in a van or on a trailer

Technical data

Description	Value
Weight	697 kg
Height	1420 mm
Width (min)	780 mm
Length(min)	2020 mm
Extension of arm	500 mm
Tip from horizontal	35° back/100° forward
Sideshift	100 mm
Vacuum system	2 circuits
Chargingvoltage	230 volt
Integrated charger	Cetek XT 14000
Chargingtime	Approx 8 hours
Battery (2 x 12v) 24 volt	2 x 90 A
Runningperiod	Approx 30 hours
Front-wheel drive	1000 Watt
Suction pads	4 unit Ø 400 mm

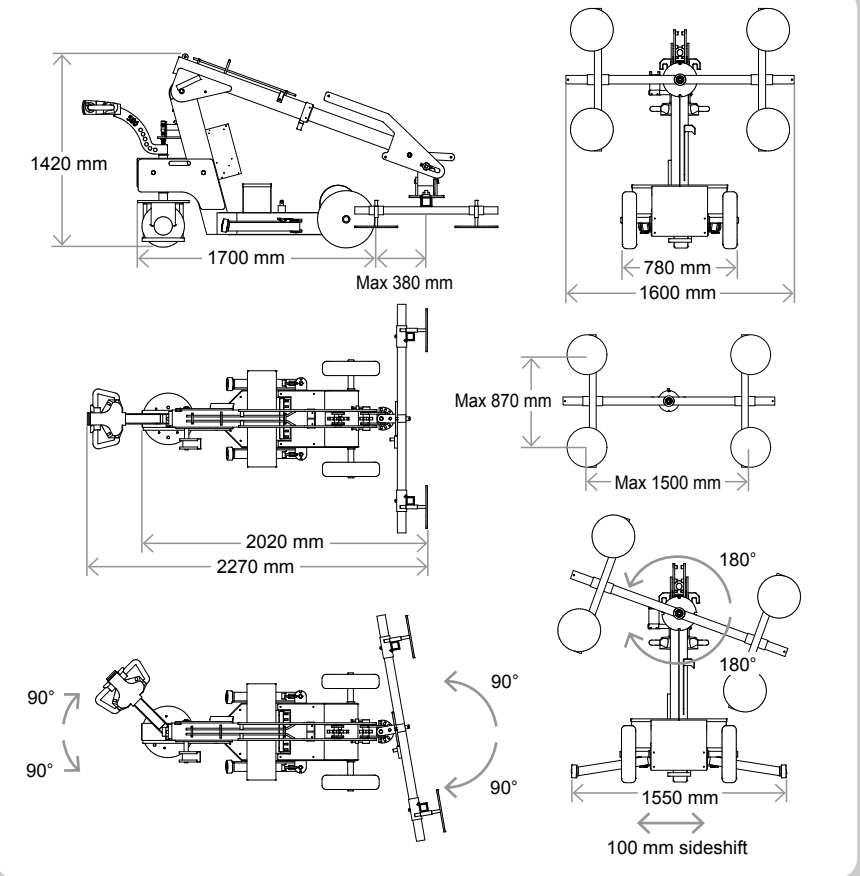
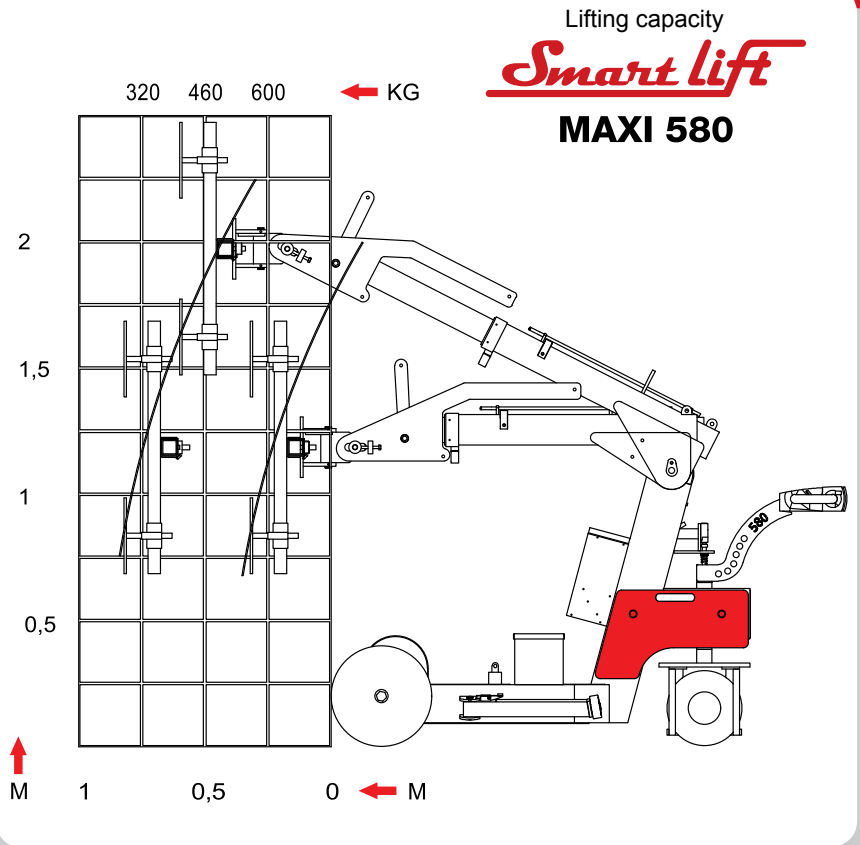

N.A. Christensensvej 39
 DK-7900 Nykøbing Mors
 Tlf.: +45 97 72 29 11
 E-mail: smart@smartlift.dk
 www.smartlift.dk