

40105R SIDE VIEW DIAGRAM

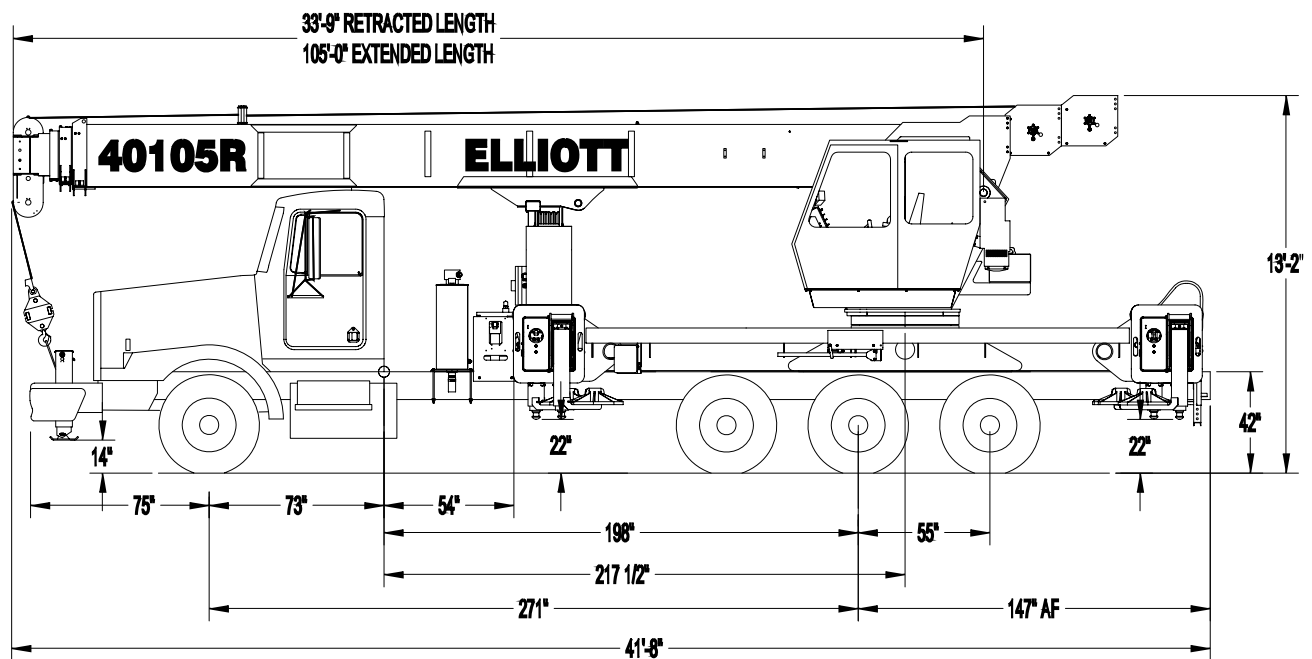

- | | | | |
|----------------------------------|-----------------------|---------------------------------|--------------------------|
| • Maximum Vertical Reach | 164'/50 m | • Powered Boom Sections | 4 |
| • Working Area | 360 Degrees | • Overall Height | 13'2"/4 m |
| • Lifting Capacity | 80,000 lbs/36 287 kg | • Operator Controls | Rotating Seated With Cab |
| • Boom Length | 105'/32 m | • Outrigger Type Front | Out-Down |
| • Crane Weight (Standard) | 38,200 lbs/17 327 kg | • Outrigger Spread Front | 26'2"/8 m |
| • Jib Lengths | 32', 49'/ 9,8 m, 15 m | • Outrigger Type Rear | Out-Down |
| • Winch Bare Drum Pull | 15,000 lbs/6804 kg | • Outrigger Spread Rear | 26'2"/8 m |

TECHNICAL SPECIFICATIONS

Crane Capacity: 80,000 lbs at 9' load radius.

Maximum Tip Height: 115' height (164' with optional 49' jib)

Control Console: Rotating seated controls with operator cab and deluxe operators seat. Station equipped with four pilot operated control levers for the main crane controls. Operator station includes LMI display, diesel heater, bubble level gauge, engine start/stop switch, signal horn button, variable speed throttle switch, lifting capacity chart, range diagram chart, boom angle indicator, system pressure gauge, 12V DC power source, and cup holder. Independent ground level electric operated outrigger controls.

Boom: Four-section fully proportional, high strength steel plated rectangular tube sections. A maximum boom tip height of 164' mounted on a truck. The boom nose contains one floating upper sheave and three lower sheaves. Assembly includes heavy-duty cylinder fittings, pivot pins, and replaceable wear pads.

Winch: Mounted at the base of the boom for a long fleet angle and flat level spooling of cable. Winch is driven by a planetary reducer and powered by a hydraulic motor. Burst-of-speed winch provides increased line speed. The winch brake is spring applied, pressure release design. Supplied with 430' of 5/8" diameter rotation resistant wire rope with a single line pull of 10,000 pounds, and a downhaul ball with swivel hook for single part line.

Load Moment Indicator System: System senses hoist cylinder pressures, boom length and boom angle with hydraulic function lockout. The display console is equipped with a bar graph showing crane utilization, boom angle or boom length, a mode select controls for main boom and jib operation, and an anti-two block with an audio/visual warning and shut-off functions to limit

Elliott Equipment Company reserves the right to change the specification of any unit at any time without prior notice. This brochure is only a statement of general specifications on the date of this publication. For more detailed info on specific Elliott trucks go to www.elliottequip.com

hook-boom point contact.

Outriggers: Two sets of out and down overframe outriggers with 26'2" span. Outriggers are configured for full span, mid span, and full retracted operation. Outriggers equipped with 22" diameter ball socket aluminum removable pads that stow on vertical outrigger legs. Front stabilizer bumper is required.

Frame: Full length, all welded rigid 4-plate design sub-frame. Sub-frame allows for bolt-on addition of aluminum bed wings, with top plate of subbase serving as a portion of the bed deck, to form a three-piece bed.

Turret: Reverse offset turret is one-piece weldment. Turret rotates on large diameter ball bearing.

Rotation: Hydraulic motor drives turret through double reduction planetary swing drive for 360 degree continuous rotation. Glide-swing drive system has manual foot applied brake

Lift: One double-acting long stroke cylinder provides smooth and stable boom elevation. Holding valve prevents boom from falling in event of hose failure.

Boom Extension: Incorporates a 2-stage hydraulic extension cylinder, attached to the largest boom section, with a proportional cable extension system driving the outermost sections.

Hoses: All high pressure hoses are wire braid reinforced with a minimum safety factor of 4 to 1.

Cylinders: All cylinders use microhoned cylinder tubing, chrome shafts, top grade packing and protective rod wipers. Cylinder-mounted holding valves provided on all load-holding cylinders.

Hydraulic System: Equipped with air-shift PTO, piston pump, SAE O-ring face seals on pressure lines, and a 10-micron return line filter. The control valve distributes all flow to hoist system, swing circuit, and other crane functions.

System is closed center type.

Oil Tank Capacity: 143 gallon mounted on top of truck frame.

Cab Equipment: Air shift PTO with indicator lights installed in truck cab. U/L approved 5:BC dry chemical fire extinguisher installed in truck cab.

Operators Manual & Video: Two CD copies and one hard copy of operation, maintenance, safety and parts manual provided with each unit. Operational and safety video provided at delivery.

Installation: Unit installed on chassis, painted, system and tank filled with oil, tested, inspected, and ready to operate.

Standard Paint: Paint turret and boom white, outriggers red, and bed and boxes black.

Bumper: Bureau of Motor Carrier Safety rear bumper.

Weight: Approximately 38,200 lbs. with 18' aluminum bed less truck.

Truck Chassis Required: Approx. 198" C.T., RBM 3,300,000 in-lb. per rail, 20,000 lb. front axle and 78,000 lb. GVWR required. Trucks must have front frame extension, 12V electrical system with high capacity alternator, cab clearance stop/tail/backup lights, and I.D. lamps. Recommended GVWR is minimum for BoomTruck with flatbed only. Contact factory when additional equipment is to be added.

Options:

Air Conditioning for Crane Cab.

49 ft. Telescopic Jib.

Gravity Leveled Work Basket.

Swing Counterweight up to 1,600 lbs.

Radio Remote Controls.

Auxiliary Winch for Faster Jib Deployment.

Much More...

LOAD CHART - MAIN BOOM, FULL-SPAN OUTRIGGERS



MODEL H4000

105-ft BOOM

MAIN BOOM LOAD RATINGS WITH FULLY EXTENDED OUTRIGGERS

MAIN BOOM LOAD RATINGS

LOAD RATINGS IN lbs WITH OUTRIGGERS AND STABILIZERS EXTENDED

LOAD RADIUS IN FEET	LOADED BOOM ANGLE	33-ft	A	LOADED BOOM ANGLE	B	LOADED BOOM ANGLE	C	LOADED BOOM ANGLE	D	LOADED BOOM ANGLE	E	LOADED BOOM ANGLE	F	
		33-ft	46-ft		57-ft		69-ft		81-ft		93-ft		105-ft	
9	72.6	80,000												
10	70.4	64,500	76.5	46,600										
12	66.4	58,100	73.9	46,600	77.9	46,600								
15	60.1	50,800	69.9	46,600	74.9	44,600	78.4	41,700						
20	48.5	39,700	62.7	38,900	69.3	36,500	74.0	34,900	77.2	30,700				
25	33.4	30,000	54.8	31,000	63.5	31,100	69.5	29,500	73.4	26,100	76.4	23,500	78.4	19,000
30			45.7	24,600	57.2	25,200	64.7	25,500	69.5	22,600	73.1	20,400	75.9	18,700
35			34.8	18,900	50.3	19,350	59.5	19,700	65.5	19,700	69.7	17,800	72.9	16,300
40			17.9	14,900	42.5	15,300	53.9	15,600	61.1	15,900	66.2	15,700	69.9	14,500
45					33.3	12,400	48.0	12,700	56.5	13,000	62.4	13,200	66.9	13,500
50					20.1	10,100	41.5	10,500	51.7	10,750	58.4	10,900	63.5	11,150
55							34.6	8,800	47.0	9,050	54.7	9,200	60.4	9,350
60							25.0	7,200	41.4	7,600	50.5	7,800	56.8	7,950
65									34.9	6,400	45.9	6,600	53.1	6,750
70									27.1	5,450	40.9	5,600	49.2	5,750
75									15.3	4,500	35.2	4,700	45.1	4,800
80											28.6	3,950	40.6	4,100
85											19.7	3,300	35.7	3,450
90													30.0	2,850
95													22.8	2,350
100													11.0	1,800
	0	18,500	0	11,900	0	8,150	0	5,450	0	3,900	0	2,500	0	1,000
DEDUCTIONS FOR STOWED JIB (lbs)		1,000		750		600		500		400		350		300

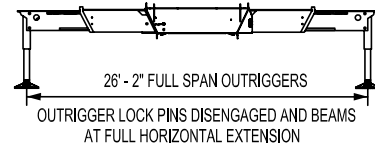

- ELLIOTT EQUIPMENT CO. SUPPLIED
 LOADLINE EQUIPMENT DEDUCTIONS:
 DOWNSHAUL WEIGHT225 lbs
 ONE SHEAVE BLOCK.....424 lbs
 TWO SHEAVE BLOCK.....592 lbs
 THREE SHEAVE BLOCK.....639 lbs
 FOUR SHEAVE BLOCK.....762 lbs
 AUXILIARY SHEAVE.....100 lbs

DEDUCTIONS FOR STOWED EXTENDABLE JIB (lbs)



Elliott Equipment Company
 4427 South 76th Circle
 Omaha, NE 68127
 Phone: 402-592-4500
 Fax: 402-592-4553
 Email: sales@elliottequip.com

Built for You.
 www.elliottequip.com

LOAD CHART - MAIN BOOM, MID-SPAN OUTRIGGERS



MODEL H4000

105-ft BOOM

MAIN BOOM LOAD RATINGS WITH MIDSPAN OUTRIGGERS

LOAD RATINGS IN lbs WITH OUTRIGGERS AND STABILIZERS EXTENDED

LOAD RADIUS IN FEET	LOADED BOOM ANGLE	33-ft	LOADED BOOM ANGLE	A 46-ft	LOADED BOOM ANGLE	B 57-ft	LOADED BOOM ANGLE	C 69-ft	LOADED BOOM ANGLE	D 81-ft	LOADED BOOM ANGLE	E 93-ft	LOADED BOOM ANGLE	F 105-ft	
9	71.3	80,000													
10	69.1	64,500	75.5	46,600											
12	65.2	58,100	72.9	46,600	77.1	46,600									
15	59.1	50,800	69.0	46,600	74.1	44,600	77.8	41,700							
20	47.7	29,600	61.7	33,300	68.4	34,000	73.4	34,900	76.6	30,700					
25	34.1	17,400	53.6	19,500	62.2	20,300	68.1	20,800	72.4	21,400	75.7	22,000	78.2	20,000	
30			44.9	13,000	55.8	13,450	63.1	13,900	68.1	14,400	71.8	14,800	74.8	15,200	
35			35.8	9,000	49.8	9,450	58.4	9,800	63.8	10,200	68.0	10,550	71.4	10,800	
40			22.3	6,300	42.5	6,750	53.1	7,100	59.8	7,400	64.7	7,700	68.5	8,000	
45					33.9	4,850	47.4	5,100	55.4	5,450	60.9	5,700	65.2	5,950	
50					22.9	3,400	41.2	3,650	50.7	3,950	57.1	4,200	61.9	4,400	
55								34.0	2,600	45.7	2,850	53.1	3,100	58.5	3,300
60								25.2	1,700	40.3	1,950	48.9	2,150	55.0	2,300
65										34.2	1,200	44.4	1,400	51.4	1,500
	0	9,800	0	4,850	0	2,400	0	800							
DEDUCTIONS FOR STOWED JIB (lbs)		1,000		750		600		500		400		350		300	

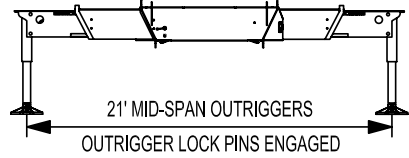

- ELLIOTT EQUIPMENT CO. SUPPLIED
LOADLINE EQUIPMENT DEDUCTIONS:
- DOWNHAUL WEIGHT225 lbs
 - ONE SHEAVE BLOCK.....424 lbs
 - TWO SHEAVE BLOCK.....592 lbs
 - THREE SHEAVE BLOCK.....639 lbs
 - FOUR SHEAVE BLOCK.....762 lbs
 - AUXILIARY SHEAVE.....100 lbs

DEDUCTIONS FOR STOWED EXTENDABLE JIB (lbs)

NOTE:

1. Operate jib by radius when main boom is fully extended.
Increase boom angle if necessary to maintain load radius.
2. When boom is retracted, operate jib by boom angles.
Do not exceed any rated jib capacities at reduced boom lengths.
3. Capacities do not exceed stability based on ISO 4305-1991.
4. Load ratings above bold line are structurally limited.
5. Personnel handling is allowed only with full span outriggers.
6. Boom load ratings are based on loaded boom radius.
Loaded boom angles are given as reference only.

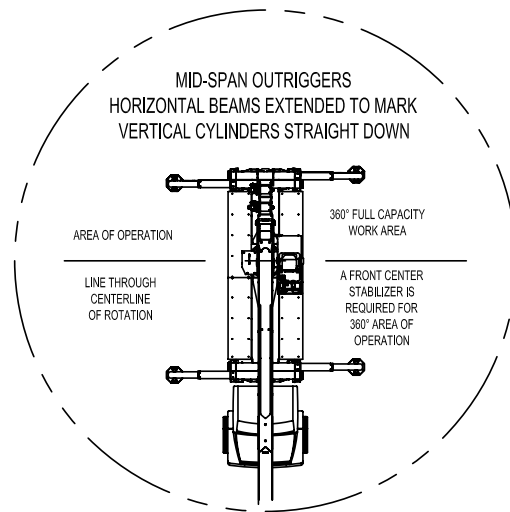

CRANE MEETS ASME B30.5 REQUIREMENTS AT TIME OF MANUFACTURE

DO NOT PAINT OVER ANY LABELS

1115620 090407



Elliott Equipment Company
4427 South 76th Circle
Omaha, NE 68127
Phone: 402-592-4500
Fax: 402-592-4553
Email: sales@elliottequip.com

Built for You.
www.elliottequip.com

LOAD CHART - MAIN BOOM, RETRACTED OUTRIGGERS



MODEL H4000 105-ft BOOM

MAIN BOOM LOAD RATINGS WITH OUTRIGGERS AT RETRACTED POSITION

RANGE DIAGRAM WITH OUTRIGGERS IN RETRACTED POSITION

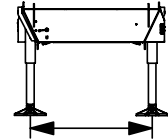
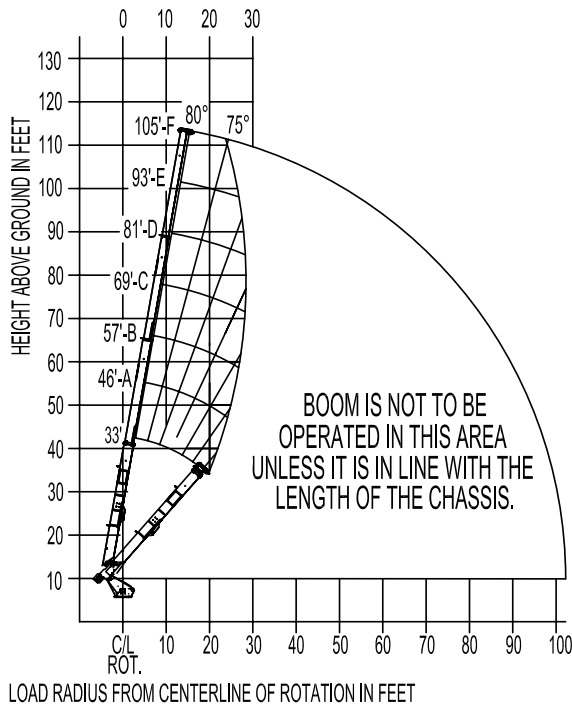

7' RETRACTED OUTRIGGERS
OUTRIGGER LOCK PINS DISENGAGED AND BEAMS
AT FULL HORIZONTAL RETRACT

- ELLIOTT EQUIPMENT CO. SUPPLIED
LOADLINE EQUIPMENT DEDUCTIONS:
- DOWNHAUL WEIGHT225 lbs
 - ONE SHEAVE BLOCK.....424 lbs
 - TWO SHEAVE BLOCK.....592 lbs
 - THREE SHEAVE BLOCK.....639 lbs
 - FOUR SHEAVE BLOCK.....762 lbs
 - AUXILIARY SHEAVE.....100 lbs

MAIN BOOM LOAD RATINGS WITH NO SPAN OUTRIGGERS

LOAD RATINGS IN lbs WITH OUTRIGGERS RETRACTED AND STABILIZERS EXTENDED

LOAD RADIUS IN FEET	LOADED BOOM ANGLE	33-ft	LOADED BOOM ANGLE	A	LOADED BOOM ANGLE	B	LOADED BOOM ANGLE	C	LOADED BOOM ANGLE	D	LOADED BOOM ANGLE	E	LOADED BOOM ANGLE	F
9	70.2	18,800												
10	68.2	15,000	74.6	16,600										
12	64.3	10,350	71.8	11,500	75.7	11,900								
15	59.3	6,050	68.3	6,900	72.9	7,150	76.2	7,400						
20	48.6	2,250	61.2	2,950	67.3	3,150	71.6	3,300	74.6	3,500				
25			53.7	850	61.5	1,000	67.0	1,150	70.7	1,300	73.5	1,400	75.7	1,500

DEDUCTIONS FOR STOWED JIB (lbs)	1,000	750	600	500	400	350	300

CRANE MEETS ASME B30.5 REQUIREMENTS AT TIME OF MANUFACTURE

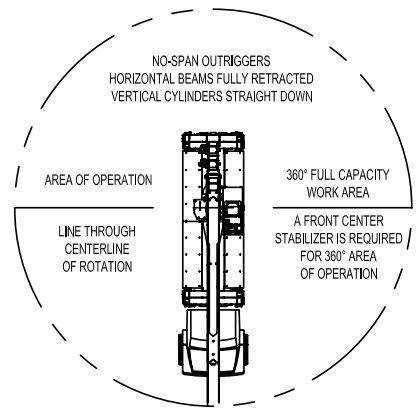

DEDUCTIONS FOR STOWED EXTENDABLE JIB (lbs)

DO NOT PAINT OVER ANY LABELS 1115620 090407

RANGE CHART - MAIN BOOM, FULL-SPAN OUTRIGGERS



MODEL H4000

105-ft BOOM

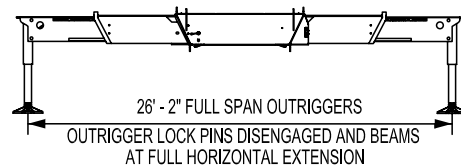
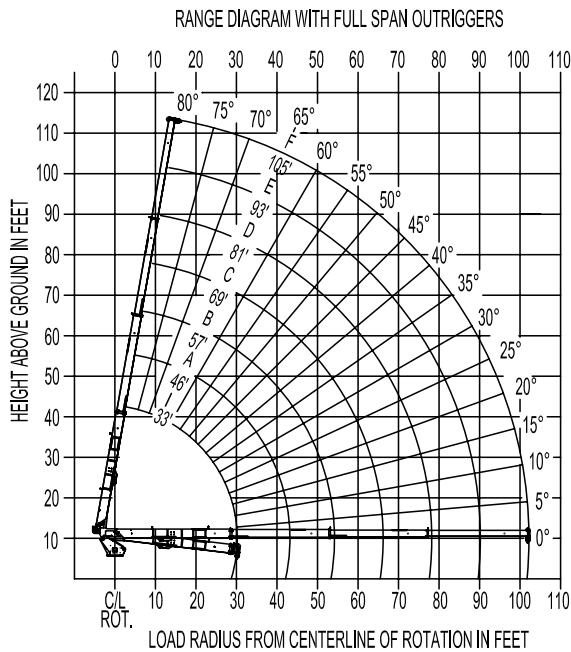

NOTE:

1. Operate jib by radius when main boom is fully extended. Increase boom angle if necessary to maintain load radius.
2. When boom is retracted, operate jib by boom angles. Do not exceed any rated jib capacities at reduced boom lengths.
3. Capacities do not exceed 85% stability.
4. Load ratings above bold line are structurally limited.
5. Personnel handling is allowed only with full span outriggers.
6. Boom load ratings are based on loaded boom radius. Loaded boom angles are given as reference only.

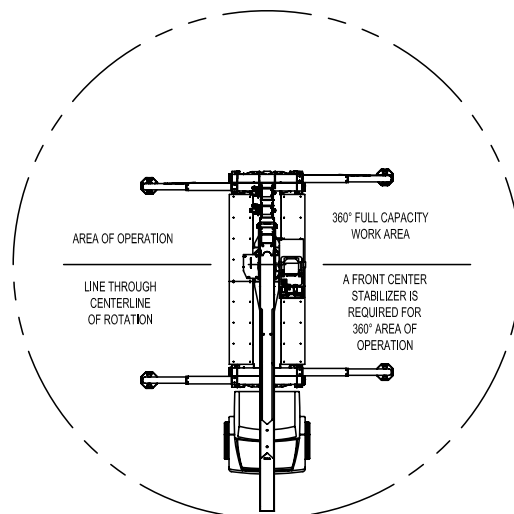

CRANE MEETS ASME B30.5 REQUIREMENTS AT TIME OF MANUFACTURE

DO NOT PAINT OVER ANY LABELS 1115620 090407



Elliott Equipment Company
4427 South 76th Circle
Omaha, NE 68127

Phone: 402-592-4500
Fax: 402-592-4553
Email: sales@elliotequip.com

Built for You.
www.elliotequip.com

RANGE CHART - MAIN BOOM, MID-SPAN OUTRIGGERS



MODEL H4000

105-ft BOOM

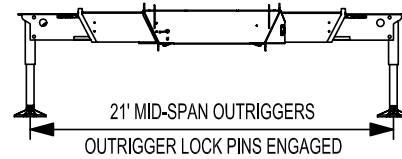

RANGE DIAGRAM WITH OUTRIGGERS IN MID-SPAN POSITION

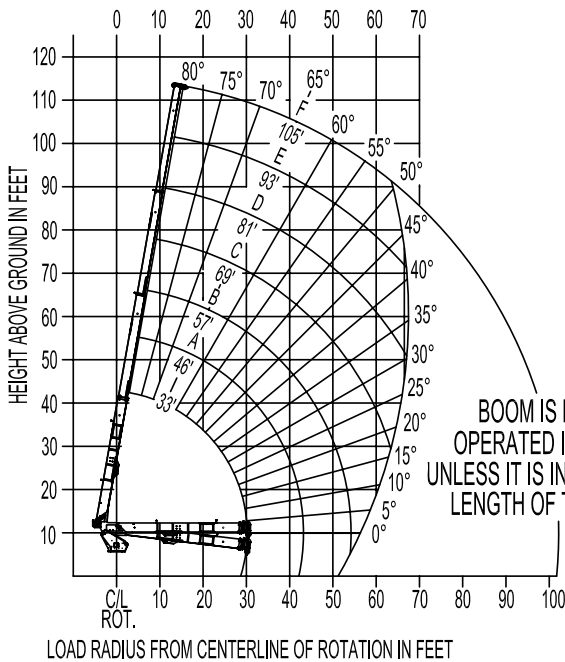

NOTE:

1. Operate jib by radius when main boom is fully extended. Increase boom angle if necessary to maintain load radius.
2. When boom is retracted, operate jib by boom angles. Do not exceed any rated jib capacities at reduced boom lengths.
3. Capacities do not exceed stability based on ISO 4305-1991.
4. Load ratings above bold line are structurally limited.
5. Personnel handling is allowed only with full span outriggers.
6. Boom load ratings are based on loaded boom radius. Loaded boom angles are given as reference only.

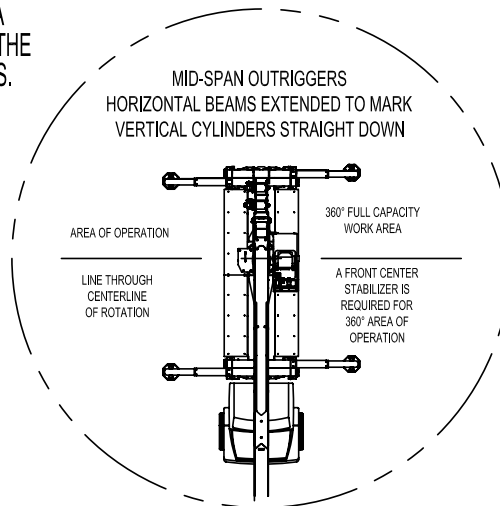

CRANE MEETS ASME B30.5 REQUIREMENTS AT TIME OF MANUFACTURE

DO NOT PAINT OVER ANY LABELS

1115620 090407

LOAD CHART - MAIN BOOM + JIB, FULL-SPAN OUTRIGGERS



MODEL H4000

105-ft BOOM

JIB LOAD RATINGS WITH FULLY EXTENDED OUTRIGGERS

LOAD RADIUS IN FEET	32-49 ft EXTENDABLE JIB			
	LOADED BOOM ANGLE	32-ft JIB 360°	LOADED BOOM ANGLE	49-ft JIB 360°
35	77.4	6,050		
40	75.2	5,500	77.6	5,100
45	73.0	5,150	75.8	4,800
50	70.8	4,850	73.9	4,500
55	68.5	4,550	72.1	4,250
60	66.2	4,300	70.1	4,000
65	63.8	4,000	68.1	3,750
70	61.3	3,700	66.0	3,450
75	58.7	3,400	63.8	3,200
80	56.1	3,250	61.7	3,000
85	53.2	2,900	59.4	2,750
90	50.2	2,600	57.0	2,500
95	46.8	2,050	54.5	2,250
100	43.2	1,550	52.0	2,000
105	39.4	1,100	49.3	1,750
110	35.3	700	46.4	1,500
115	31.0	500	43.4	1,250
120			40.2	950
125			36.6	600

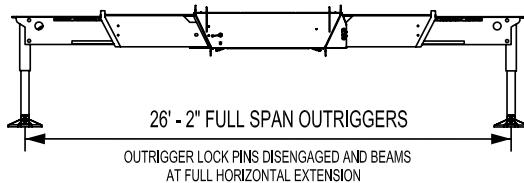
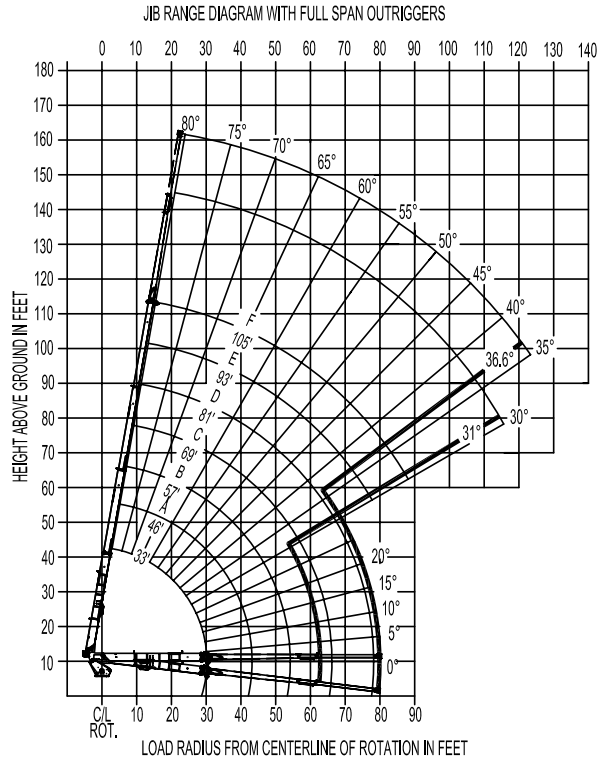

- NOTE:
1. Operate jib by radius when main boom is fully extended. Increase boom angle if necessary to maintain load radius.
 2. When boom is retracted, operate jib by boom angles. Do not exceed any rated jib capacities at reduced boom lengths.
 3. Capacities do not exceed 85% stability.
 4. Load ratings above bold line are structurally limited.
 5. Personnel handling is allowed only with full span outriggers.
 6. Boom load ratings are based on loaded boom radius. Loaded boom angles are given as reference only.

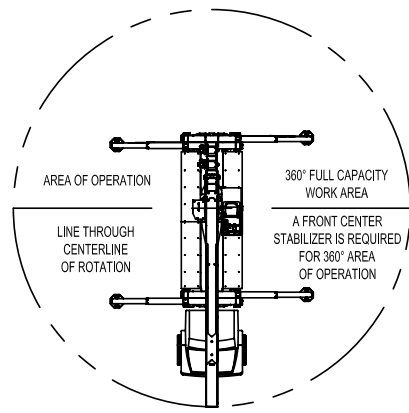

CRANE MEETS ASME B30.5 REQUIREMENTS AT TIME OF MANUFACTURE

DO NOT PAINT OVER ANY LABELS 1115620 090407



Elliott Equipment Company
 4427 South 76th Circle
 Omaha, NE 68127
 Phone: 402-592-4500
 Fax: 402-592-4553
 Email: sales@elliottequip.com

Built for You.
 www.elliottequip.com

LOAD CHART - MAIN BOOM + JIB, MID-SPAN OUTRIGGERS



MODEL H4000

105-ft BOOM

JIB LOAD RATINGS WITH MID-SPAN OUTRIGGERS

32-49 ft EXTENDABLE JIB				
LOAD RADIUS IN FEET	LOADED BOOM ANGLE	32-ft JIB 360°	LOADED BOOM ANGLE	49-ft JIB 360°
35	77.4	6,050		
40	75.2	5,500	77.6	5,100
45	73.0	5,150	75.8	4,800
50	70.8	4,850	73.9	4,500
55	68.5	4,550	72.1	4,250
60	66.0	4,050	70.1	4,000
65	63.1	3,100	68.1	3,750
70	60.1	2,300	65.6	3,100
75	57.1	1,600	63.0	2,350
80	54.1	1,000	60.5	1,800
85	51.0	500	57.9	1,250
90			55.3	800

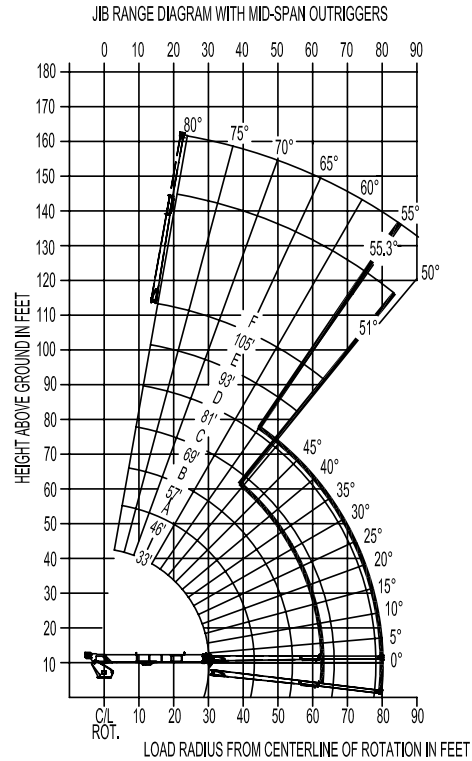
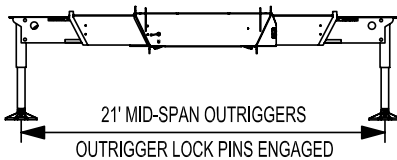

- NOTE:
1. Operate jib by radius when main boom is fully extended. Increase boom angle if necessary to maintain load radius.
 2. When boom is retracted, operate jib by boom angles. Do not exceed any rated jib capacities at reduced boom lengths.
 3. Capacities do not exceed stability based on ISO 4305-1991.
 4. Load ratings above bold line are structurally limited.
 5. Personnel handling is allowed only with full span outriggers.
 6. Boom load ratings are based on loaded boom radius. Loaded boom angles are given as reference only.

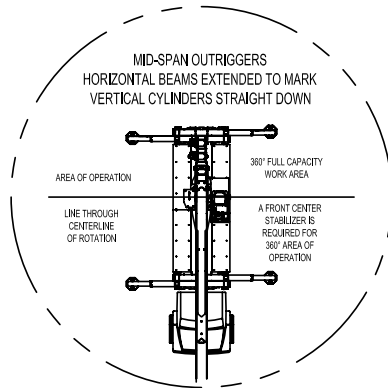

CRANE MEETS ASME B30.5 REQUIREMENTS AT TIME OF MANUFACTURE

DO NOT PAINT OVER ANY LABELS

1115620 090407

MAIN BOOM WINCH DATA



MODEL H4000

105-ft BOOM

PARTS OF LINE

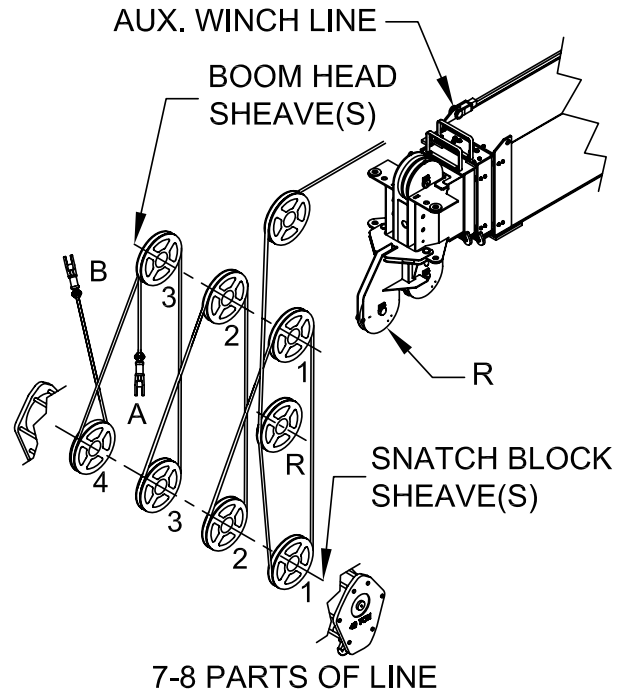
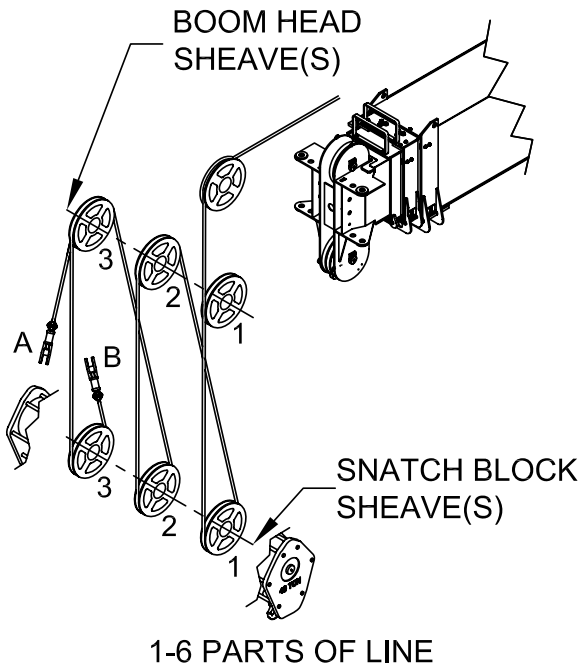

NOTICE:

- DO NOT DEADHEAD LINE BLOCK AGAINST BOOM TIP WHEN EXTENDING BOOM.
- KEEP AT LEAST 5 WRAPS OF LOADLINE ON THE WINCH DRUM AT ALL TIMES.
- USE ONLY 5/8" DIAMETER WIRE ROPE, AS SPECIFIED, WITH THE PROPER BREAKING STRENGTH LISTED.
- ANTI-TWO-BLOCK SYSTEM MUST BE IN GOOD OPERATING CONDITION BEFORE OPERATING CRANE. SEE OPERATION & SAFETY MANUAL.

PARTS OF LINE	SHEAVE(S) ON BOOM HEAD	SHEAVE(S) ON SNATCH BLOCK	5/8" - SPIN RESISTANT (5:1 S.F.) 50,000-lbs. BREAKING STRENGTH
1	1	A	10,000 lbs
2	1B	1	20,000 lbs
3	12	1A	30,000 lbs
4	12B	12	40,000 lbs
5	123	12A	50,000 lbs
6	123B	123	60,000 lbs
7	R123	123A	70,000 lbs
8	R123B	1234	80,000 lbs

A-DEAD END FOR ODD PARTS OF LINE
 B-DEAD END FOR EVEN PARTS OF LINE
 R-ROOSTER SHEAVE REQUIRED WHEN USING 7 AND 8 PARTS OF LINE

CRANE MEETS ASME B30.5 REQUIREMENTS AT TIME OF MANUFACTURE

DO NOT PAINT OVER ANY LABELS

1115620 090407



Elliott Equipment Company
 4427 South 76th Circle
 Omaha, NE 68127
 Phone: 402-592-4500
 Fax: 402-592-4553
 Email: sales@elliottequip.com

Built for You.
www.elliottequip.com

TRUCK CHASSIS SPECIFICATIONS

	40105R BoomTruck
Wheelbase (WB)	288" / 731 cm
Cab to Tandem (CT)	198" / 503 cm
Cab to End of Frame (EOF)	345" / 876 cm
Frame Section Modulus	30.0 in ³ -110,000 psi / 758,428 kPa
Front Axle Gross Weight Rating	20,000 lb / 9,072 kg
Rear Axle Gross Weight Rating	58,000 lb / 26,308 kg
Integral Front Frame Rails	Required for Front Stabilizer

Chassis data is minimum general requirements-not for engineering.
 Actual dimensions and truck data will depend on truck selection and axle configuration.
 *Minimum chassis weight is required to meet 85% stability requirements.

OPTIONS



Radio Remote Control

Interference protected radio remotes let you get closer to your work and have full control over your machine. Includes battery charging feature and optional LMI screen.



Pin-On Jib Attachments

One piece & two piece telescoping or fixed jibs that stow on the side of the boom for easy placement while on the worksite.



Air Conditioning in Crane Cab

Work all day in comfort with an high efficiency air conditioning system mounted on the rear of the crane control cab.



Auxiliary Winch System

Take advantage of the auxiliary winch to quickly deploy Elliott's telescopic jib or perform wireline work applications.



Tool Boxes

Optional tool boxes and bed storage can accommodate any storage need for tools, work materials and more.

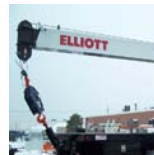

Hook Block for Multi-Part Line

Elliott can include a hook block device for up to 8 parts of line to improve lifting capabilities and allow you to maximize your use of the crane.



Gravity Leveled Basket

Elliott's pin-on work platform pins onto the boom for easy installation and removal. Gravity leveling and mechanical rotation makes it a great accessory for any worksite.



Body Mounted Hose Reels and Circuits

Let us work with you to customize your tool compatibility by adding hose reels or hydraulic circuits to the crane bed.