

**ROUGH TERRAIN
HYDRAULIC CRANE**

KATO KR-22H

KATO KR-22H ROUGH TERRAIN CRANE

Major Specifications

Crane Module

Name		22 ton hoisting rough terrain crane
Model		Kato KR-22H
<ul style="list-style-type: none"> Crane Performance 		
Maximum total rated load	6.70m boom	22,000kg x 3.0m (7 cables)
	11.00m boom	12,000kg x 6.0m (4 cables)
	15.20m boom	12,000kg x 5.5m (4 cables)
	21.60m boom	8,000kg x 6.5m (3 cables)
	28.00m boom	6,000kg x 7.0m (2 cables)
	5.00m jib	3,100kg x 11.0m (1 cable)
	Rooster sheave	3,400 kg (1 cable)
Boom length		6.7m – 28.0m
Jib length		5.0m
Maximum lift above ground level		28.7m (boom) 34.1m (jib)
Lifting rope speed	Main hoist	118m/min (4 th tier)
	Secondary hoist	102m/min (2 nd tier)
Hook speed	Main	(Rope cable no. – 7) 16.8m/min (4 th tier)
	Secondary	(Rope cable no. – 1) 102.0m/min (2 nd tier)
Boom hoisting range		-10° – 81°
Boom raising time		0° – 81°/33sec
Boom extension time		6.7m – 28.0m/73 sec
Swivelling speed		2.6rpm
Rear end swing radius		2.420m (slide sheave) 2.140m (counterweight)
<ul style="list-style-type: none"> Crane module equipment and construction 		
Boom format		Box 6-level hydraulic telescopic
Jib format		Box 1-level boom compartment storage type
Boom telescope		Combination use of hydraulic cylinders and wire ropes 2 & 3-level isometric, and 4, 5 & 6-level isometric telescopic
Boom hoisting unit		Hydraulic cylinder direct pressing type
Lifting rope unit		2 single winches, oil motor drive – spur gear reduction system Automatic brake (stepping brake, free lowering and power lowering devices)
Swivelling unit		Oil motor drive – planetary gear reduction system (built-in negative brake) Free lock switch type
Swivelling circle		Ball bearing type
Outrigger unit	Format	All hydraulic H model (float and vertical cylinder combination)
	Reach width	5,800mm (maximum reach)
		4,600mm (intermediate reach)
		3,400mm (intermediate reach) 2,040mm (minimum reach)
Rope		
Main hoist	SeS (48) + 6 x WS (31) f 16mm x 100m	
	IWRC 6 x Fi (29) f 16mm x 75m	

KATO KR-22H ROUGH TERRAIN CRANE

<ul style="list-style-type: none"> Hydraulics 		
Oil pumps	Double variable plunger model, gear + plunger model	
Oil motor	Lifting	Axial plunger
	Swivelling	Axial plunger
Control bulb	Multiple auto recovery (hydraulic compensated flow control valve)	
Cylinder	Double acting	
Oil reserve	400 l	
<ul style="list-style-type: none"> Safety Devices 		
	ACS (overload protection and voice alarm), work scope restriction unit, outrigger reach width auto detector, boom natural lowering prevention unit, over-lift prevention unit, drum hold safety unit, auto brake, irregular winding prevention unit, hydraulic safety valve, outrigger lock, angle indicator, swivelling warning light, hydraulic fluid overheat alarm, hydraulic fluid filter blockage alarm	
<ul style="list-style-type: none"> Standard Equipment 		
	Hydraulic dehumidifying air conditioner, AM/FM clock radio, drum rotation indicator, intermittent ceiling wiper (with washer)	
<ul style="list-style-type: none"> Optional Equipment 		
	Winch monitoring camera, TV receiver	

Carrier Module

<ul style="list-style-type: none"> Driving Performance 		
Maximum speed	49km/h	
Hill-climbing performance	0.6 (tan ?)	
Minimum turning radius	7.5m (2-wheel steering)	
	4.7m (4-wheel steering)	
<ul style="list-style-type: none"> Measurements & Weights 		
Total length	8,460mm	
Total width	2,395mm	
Total height	3,400mm	
Wheel base	3,300mm	
Wheel tread	Front wheels	1,970mm
	Rear wheels	1,970mm
Passengers	1	
Total carriage weight	23,705kg	
	Forward axle weight	11,840kg
	Rear axle weight	11,865kg
<ul style="list-style-type: none"> Engine 		
Name	Mitsubishi 6D16-T (with turbo)	
Model	6 cylinder, water cooled 4 cycles. Direct fuel-injected diesel engine	
Total exhaust	7,545cc	
Maximum output	220ps/2,800rpm	
Maximum torque	65kg·m/1,600rpm	

KATO KR-22H ROUGH TERRAIN CRANE

• Base driving equipment and construction		
Driving formats		Switches between 2-wheel drive (4 x 2) and 4-wheel drive (4 x 4)
Torque convertor		3 elements. 1-level (with auto lock-up clutch)
Transmission model		Auto and manual transmission
Number of speeds		Four speeds when moving forward. Two speeds when moving backwards (Hi/low switch)
Axle model		Full floating type (both front and rear axles)
Main brake		2 system pneumatic-hydraulic combination. 4-wheel disc brake
Parking brake		Mechanical & propeller shaft brake internal expanding type
Auxiliary brake		Torque convertor lock-up interlocking exhaust brake Auxiliary braking unit for work
Suspension	Front axle	Coil spring 4-ring (with hydraulic lock cylinder)
	Rear axle	Coil spring 4-ring (with hydraulic lock cylinder)
Steering unit	Format	All hydraulic power steering With reverse steering correction mechanism
	Mode	Forward 2wheel steering, 4wheel steering, crab steering, rear 2-wheel steering, independent front and rear wheel steering
Tyre size	Front wheels	385/95 R25 170E ROAD
	Rear wheels	385/95 R25 170E ROAD
Fuel tank		300 l
• Safety Devices		
		Camera for reversing, powered/electric remote controlled side mirrors, emergency steering unit, back wheel steering auto-lock device, over shift prevention unit, brake fluid leakage alarm, suspension lock unit, auxiliary brakes for work, over-run alarm, radiator liquid level alarm, air filter blockage alarm

**KATO KR-22H ROUGH TERRAIN CRANE
TOTAL RATED LOAD IN TONNES**

This document should be read in conjunction with the AML

Outrigger Maximum Reach (5.8 m) (Total Perimeter)					
Boom Length Working Radius	6.7 m	11.0 m	15.2 m	21.6 m	28.0 m
3.0 m	22.00	12.00	12.00	8.00	
3.5 m	20.00	12.00	12.00	8.00	
4.0 m	17.00	12.00	12.00	8.00	6.00
4.5 m	15.00	12.00	12.00	8.00	6.00
5.0 m		12.00	12.00	8.00	6.00
5.5 m		12.00	12.00	8.00	6.00
6.0 m		12.00	11.50	8.00	6.00
6.5 m		11.30	10.60	8.00	6.00
7.0 m		9.70	9.40	7.85	6.00
8.0 m		7.35	7.20	7.10	5.90
9.0 m		5.70	5.60	6.35	5.35
10.0 m			4.50	5.25	4.80
11.0 m			3.60	4.35	4.30
12.0 m			2.90	3.65	3.85
13.0 m			2.30	3.05	3.40
14.0 m				2.60	2.90
15.0 m				2.20	2.50
16.0 m				1.80	2.10
17.0 m				1.50	1.80
18.0 m				1.20	1.55
19.0 m				1.00	1.30
20.0 m				0.85 (19.6 m)	1.10
21.0 m					0.95
22.0 m					0.80
23.0 m					0.65
24.0 m					0.50
25.0 m					0.35
Hazardous Angle	-	-	-	-	-

**KATO KR-22H ROUGH TERRAIN CRANE
TOTAL RATED LOAD IN TONNES**

This document should be read in conjunction with the AML

Outrigger Intermediate Reach (4.6 m) (Laterally)					
Boom Length Working Radius	6.7 m	11.0 m	15.2 m	21.6 m	28.0 m
3.0 m	22.00	12.00	12.00	8.00	
3.5 m	20.00	12.00	12.00	8.00	
4.0 m	17.00	12.00	12.00	8.00	6.00
4.5 m	15.00	12.00	12.00	8.00	6.00
5.0 m		12.00	12.00	8.00	6.00
5.5 m		10.00	10.00	8.00	6.00
6.0 m		8.50	8.40	8.00	6.00
6.5 m		7.20	7.10	7.90	6.00
7.0 m		6.20	6.10	6.85	6.00
8.0 m		4.65	4.55	5.30	5.65
9.0 m		3.60	3.50	4.20	4.50
10.0 m			2.70	3.40	3.70
11.0 m			2.05	2.75	3.05
12.0 m			1.50	2.25	2.55
13.0 m			1.05	1.85	2.10
14.0 m				1.45	1.75
15.0 m				1.10	1.45
16.0 m				0.85	1.15
17.0 m				0.60	0.90
18.0 m				0.40	0.70
19.0 m					0.50
20.0 m					0.35
Hazardous Angle	-	-	-	18°	38°

**KATO KR-22H ROUGH TERRAIN CRANE
TOTAL RATED LOAD IN TONNES**

This document should be read in conjunction with the AML

Outrigger Intermediate Reach (3.4 m) (Laterally)					
Working Radius \ Boom Length	6.7 m	11.0 m	15.2 m	21.6 m	28.0 m
3.0 m	22.00	12.00	12.00	8.00	
3.5 m	15.20	12.00	12.00	8.00	
4.0 m	11.40	11.00	10.00	8.00	6.00
4.5 m	8.95	8.60	8.40	8.00	6.00
5.0 m		6.95	6.85	7.00	6.00
5.5 m		5.75	5.65	6.20	6.00
6.0 m		4.80	4.70	5.40	5.30
6.5 m		4.05	3.95	4.65	4.70
7.0 m		3.45	3.35	4.00	4.15
8.0 m		2.50	2.40	3.05	3.30
9.0 m		1.80	1.70	2.35	2.65
10.0 m			1.10	1.85	2.10
11.0 m			0.60	1.40	1.65
12.0 m				1.00	1.30
13.0 m				0.65	0.95
14.0 m				0.50 (13.5 m)	0.70
15.0 m					0.45
Hazardous Angle	-	-	30°	42°	53°

**KATO KR-22H ROUGH TERRAIN CRANE
TOTAL RATED LOAD IN TONNES**

This document should be read in conjunction with the AML

Outrigger Minimum Reach (2.04 m) (Laterally)					
Boom Length Working Radius	6.7 m	11.0 m	15.2 m	21.6 m	28.0 m
3.0 m	7.80	7.50	7.00	7.00	
3.5 m	6.10	5.80	5.40	5.60	
4.0 m	4.80	4.50	4.30	4.55	3.80
4.5 m	3.80	3.50	3.40	3.80	3.80
5.0 m		2.80	2.70	3.20	3.25
5.5 m		2.20	2.10	2.65	2.75
6.0 m		1.70	1.60	2.25	2.35
6.5 m		1.30	1.20	1.85	2.00
7.0 m		0.90	0.80	1.55	1.70
8.0 m				1.00	1.20
Hazardous Angle	-	30°	55°	62°	69°

**KATO KR-22H ROUGH TERRAIN CRANE
TOTAL RATED LOAD IN TONNES**

This document should be read in conjunction with the AML

Outrigger Maximum Reach (5.8 m)		
Boom Angle (°)	Working Radius (m)	Load (ton)
81.0	4.0	3.10
73.0	8.5	3.10
68.8	11.0	3.10
65.0	13.0	2.65
60.0	15.5	2.20
57.0	17.0	2.00
56.0	17.4	1.85
50.0	20.1	1.25
45.0	22.1	0.90
40.0	23.9	0.65
35.0	25.6	0.45
30.0	27.1	0.30
Hazardous Angle	25°	

Outrigger Intermediate Reach (4.6 m)		
Boom Angle (°)	Working Radius (m)	Load (ton)
81.0	4.0	3.10
73.0	8.5	3.10
68.8	11.0	3.10
65.0	13.0	2.30
60.0	15.4	1.55
57.0	16.8	1.20
56.0	17.2	1.10
50.0	19.9	0.60
45.0	22.0	0.30
Hazardous Angle	42°	

Outrigger Intermediate Reach (3.4 m)		
Boom Angle (°)	Working Radius (m)	Load (ton)
81.0	4.0	3.10
73.0	8.5	3.10
68.8	10.8	1.90
65.0	12.7	1.25
60.0	15.0	0.65
57.0	16.5	0.35
56.0	16.9	0.30
Hazardous Angle	54°	

KATO KR-22H ROUGH TERRAIN HYDRAULIC CRANE

CAUTIONS – WHEN USING THE OUTRIGGER

1. The total rated load tables display the maximum load under warranty in a state where the machine is set level on level and firm ground and includes the weight of the hook and other hoisting accessories.

The sections boxed in bold () are set out according to the machinery's strength. Other areas are set out according to the machine's degree of stability.

HOOK TYPE	22,000 kg	3,400 kg
WEIGHT	160 kg	60 kg

2. Since the working radius is based on the actual values including the flex of the boom, please ensure work is carried out with the working radius as the standard.
3. Total rated loads below the bold lines do not exceed 75% of tipping load.
4. The jib working radius displays values when work is carried out with a jib attached to a 28.0 m boom. Please use just the boom angle as the standard when doing jib work with booms of other lengths.
5. Lateral lifting performance differs according to the outrigger's reach. Consequently, please carry out work for the respective reach conditions according to the total rated load tables. For forward and backward lifting performance, please carry out work according to the total rated load table for the outrigger maximum reach.

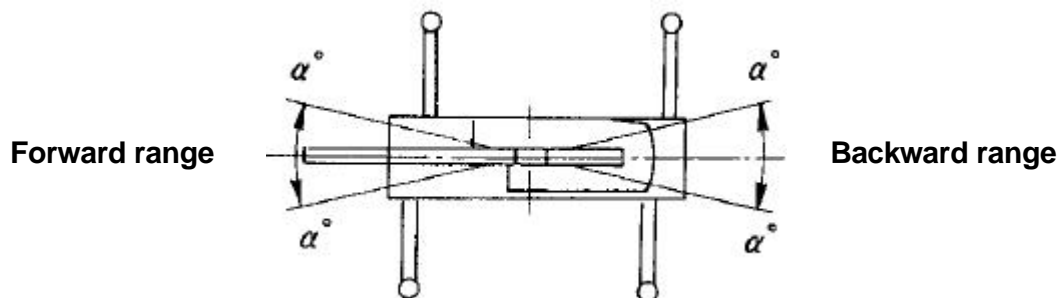

Outrigger reach status	Intermediate reach (4.6m)	Intermediate reach (3.4m)	Minimum reach
Area α°	35	20	3

6. Please do not carry out jib work at the outrigger minimum reach.
7. The total rated load for the rooster sheave is equivalent to the value after subtracting the 22 tonne hook weight (160 kg) from the total rated boom load and the limit shall be 3,400 kg.
8. When the boom length exceeds the stipulated length, please carry out work at the total rated load for either the stipulated length, or at a length for a boom which is one step longer, whichever is the smaller total rated load.
9. When carrying out boom work with a jib or with a rooster sheave attached, in addition to the weight of accessory hoists, please subtract 440 kg from the total rated load when a jib is attached or 90 kg when a rooster sheave is attached.
10. The hazardous angle for booms in each work situation is as per the tables. Please exercise sufficient caution since the crane can topple over even without any load if the boom is lower than the hazardous angle.

11. The number of standard hook cables is as per the table below. However, when using a number of cables other than for the standard hook, please use a limit of 3,300 kg for each wire rope.

Boom length	6.7m	11.0 – 15.2m	21.6m	28.0m	Jib/rooster sheave
No. of lifting cables	7	4	3	2	1

12. The total rated load tables do not include the impact of wind. Please halt work when the instantaneous wind speeds exceeds 10m/sec.
13. When carrying out work that exceeds the total rated load and when the crane has not been used correctly, it will topple over or get damaged. In these instances, the crane's warranty is invalidated.

**KATO KR-22H ROUGH TERRAIN CRANE
TOTAL RATED LOAD IN TONNES**

This document should be read in conjunction with the AML

Not using the Outrigger Fixed Hoisting						
Working Radius (m)	6.7 m Boom		11.0 m Boom		15.2 m Boom	
	Forward	Total Perimeter	Forward	Total Perimeter	Forward	Total Perimeter
3.0		6.00		5.50		5.20
3.5	8.50	4.50	8.50	4.10	8.00	3.80
4.0	8.50	3.30	8.50	3.20	8.00	3.00
4.5	7.50	2.55	7.20	2.55	6.50	2.40
5.0			6.10	2.00	5.40	1.90
5.5			5.10	1.55	4.55	1.50
6.0			4.25	1.20	3.85	1.15
6.5			3.55	0.90	3.30	0.85
7.0			3.00	0.65	2.80	
8.0			2.15		2.05	
9.0			1.55		1.50	
10.0					1.00	
11.0					0.60	
Hazardous Angle	-	-	-	30°	30°	56°

Not using the Outrigger Driving while suspending a load (under 2 km/hr)						
Working Radius (m)	6.7 m Boom		11.0 m Boom		15.2 m Boom	
	Forward	Total Perimeter	Forward	Total Perimeter	Forward	Total Perimeter
3.0		4.80		4.40		4.00
3.5	6.80	3.60	6.40	3.30	5.90	3.00
4.0	6.80	2.65	6.40	2.55	5.90	2.40
4.5	6.00	2.05	5.50	2.05	5.00	1.90
5.0			4.75	1.50	4.30	1.40
5.5			4.10	1.05	3.65	1.00
6.0			3.40	0.65	3.10	0.60
6.5			2.85		2.65	
7.0			2.40		2.25	
8.0			1.65		1.60	
9.0			1.00		1.00	
10.0					0.50	
Hazardous Angle	-	-	-	42°	35°	60°

KATO KR-22H ROUGH TERRAIN HYDRAULIC CRANE

CAUTIONS – WHEN NOT USING THE OUTRIGGER

1. The total rated load tables display the maximum load under warranty for this crane when tyre air pressure is at the specified pressure on firm and level ground and the suspension lock cylinders have been contracted to a minimum. The values include the weight of the hook and other hoisting accessories.

The sections boxed in bold () are set out according to the machinery's strength. Other areas are set out according to the machine's degree of stability. (The stipulated tyre air pressure is 9.0 kg/cm²).

2. Since the working radius is based on the actual values including the flex of the boom, please ensure work is carried out with the working radius as the standard.
3. Total rated loads below the bold lines do not exceed 75% of tipping load.
4. The total rated loads differ according to forward performance or entire perimeter performance. Please exercise due caution when swivelling from the forward area to a lateral area since there is a risk of overload.

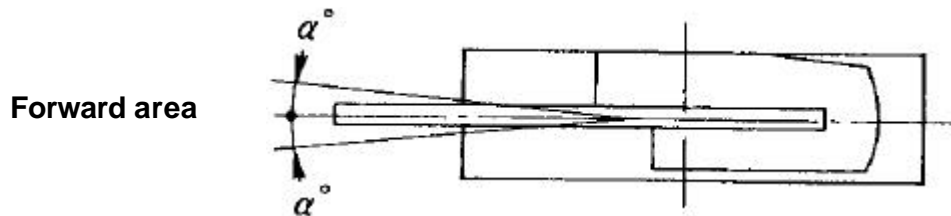

Crane work	Fixed hoisting	Driving while suspending a load
Area α°	1	1

5. The total rated load for the rooster sheave is equivalent to the value after subtracting the 22 tonne hook weight (160 kg) from the total rated boom load and the limit shall be 3,400 kg.
6. Please do not carry out boom work, jib work or free lowering work when the boom length exceeds 15.2m.
7. Please carry out fixed crane work with the parking brake active.
8. When driving while suspending a load, turn the high/low switch to "ON" (low range) and have the shift lever at speed 1.
9. While driving while suspending a load, keep the load close to the ground so that it does not sway and proceed at under 2 km/hr. In particular, exercise caution with cornering, sudden acceleration and sudden braking.
10. Do not carry out crane work when driving while suspending a load.
11. The hazardous angle for booms in each work situation is as per the tables. Please exercise due caution since the crane can topple over even without any load if the boom is lower than the hazardous angle.

12. The number of standard hook cables is as per the table below. However, when using a number of cables other than for the standard hook, please use a limit of 3,300 kg for each wire rope.

Boom length	6.7m	11.0 – 15.2m	Rooster sheave
No. of lifting cables	7	4	1

13. When carrying out work that exceeds the total rated load and when the crane has not been used correctly, it will topple over or get damaged. In these instances, the crane's warranty is invalidated.

**KATO KR-22H ROUGH TERRAIN CRANE
TOTAL RATED LOAD IN TONNES**

WORKING RANGE DIAGRAM

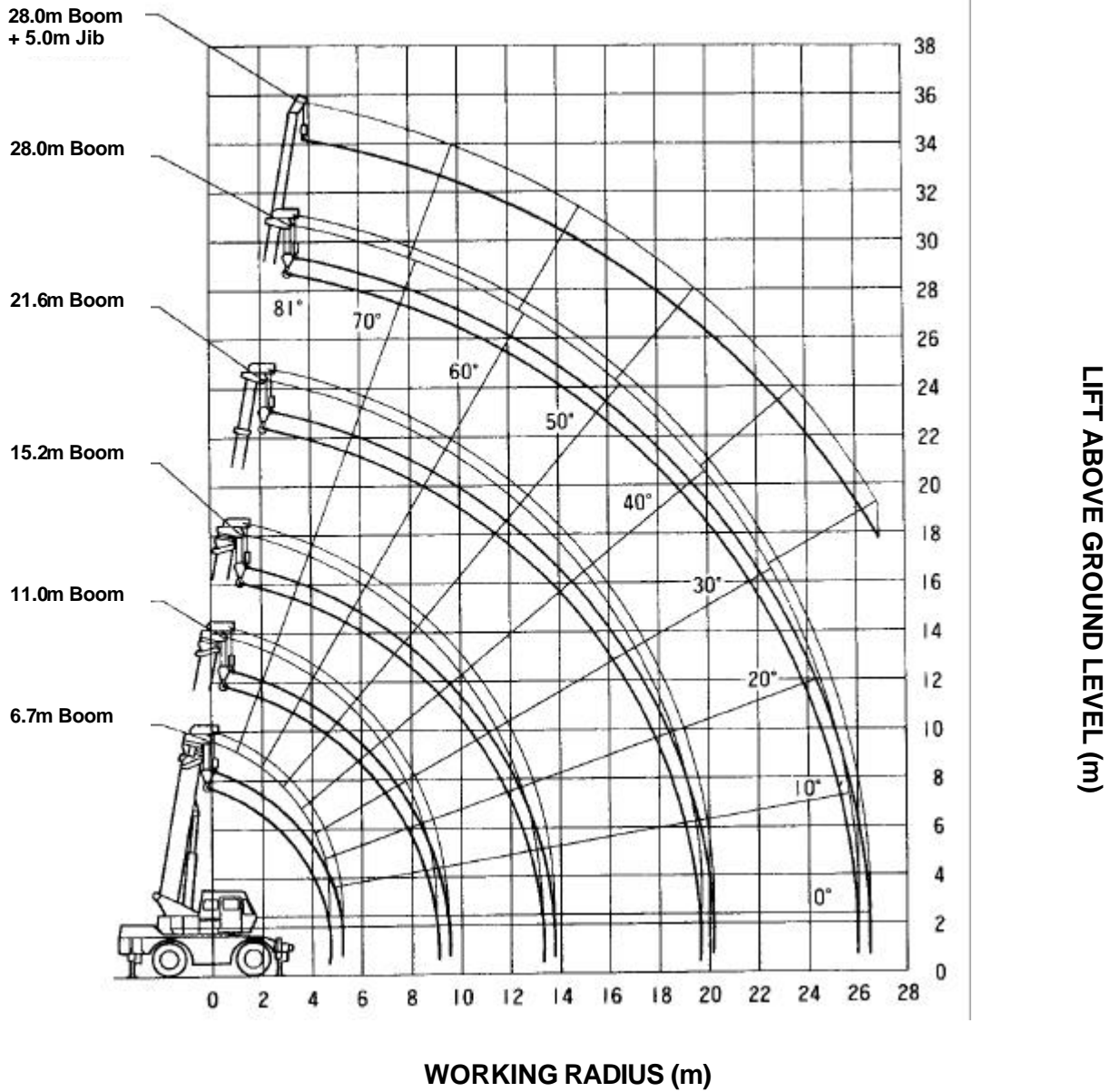

**Notes: 1. This figure does not include boom or jib flexing.
2. This figure shows the outrigger maximum reach (full perimeter)**

KATO KR-22H ROUGH TERRAIN CRANE TOTAL RATED LOAD IN TONNES

Width of Theoretical Minimum Intersecting Aisle

- **Turning right with 2-wheel steering**

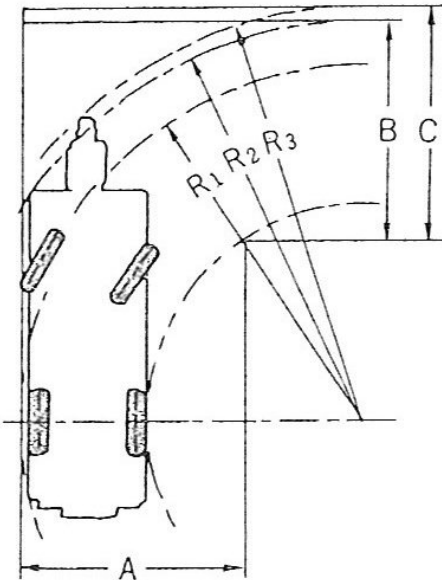

- $R_1 = 7.50\text{m}$
(Minimum turning radius)
- $R_2 = 8.43\text{m}$
(Vehicle body turning radius)
- $R_3 = 8.73\text{m}$
(Boom tip turning radius)
- $A = 4.64\text{m}$ (entry aisle width)
- $B = 4.64\text{m}$ (vehicle body exit aisle width)
- $C = 4.95\text{m}$ (boom tip exit aisle width)

- **Turning right with 4-wheel steering**

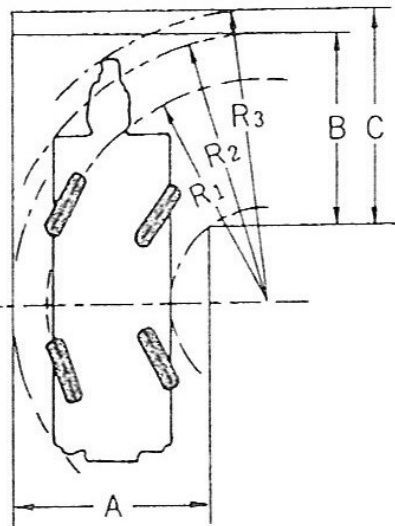

- $R_1 = 4.70\text{m}$
(Minimum turning radius)
- $R_2 = 5.67\text{m}$
(Vehicle body turning radius)
- $R_3 = 6.18\text{m}$
(Boom tip turning radius)
- $A = 4.05\text{m}$ (vehicle body entry aisle width)
- $B = 4.05\text{m}$ (vehicle body exit aisle width)
- $C = 4.56\text{m}$ (boom tip exit aisle width)

NB: The above numbers are calculated values.

- Fully equipped (compulsory automobile inspection registration weight), the KR-22H meets the B criteria of the basic access criteria. Please store the hook in the set location when driving.

Scale: 1/100 units (mm)

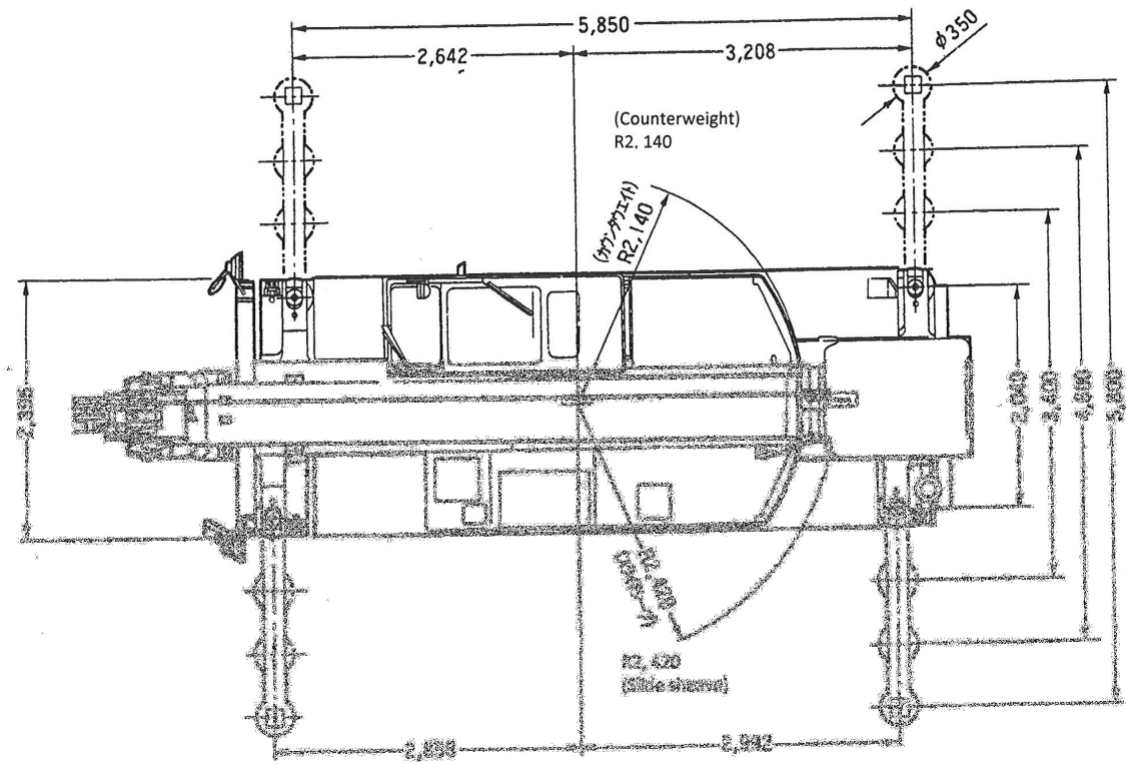

Scale: 1/100 units (mm)

