

New
lifting
device

SL 608 Outdoor

for outdoor and indoor use

A powerful lift suitable for outdoor use

SL 608 Outdoor is suitable for outdoor lifting assignments for example on construction sites. The lift is the second most powerful in the Smartlift range with a lifting capacity up to 608 kg.

SL 608 Outdoor
lifts up to 608 kg

- Off road with front-wheel drive
- Manoevrable with dual rear wheels
- Foam filled tyres
- Self-driven
- Electronic brake
- Lifting height 2950 mm (centre of yoke)
- 2 vacuum circuits with 2 pumps
- 4 Suction pads Ø 400 mm
- Ergonomic operation handle
- Waterproof according to ip65



Larger window sections and heavier windows with up to three layers of glass still call for even stronger lifting capacity. SL 608 Outdoor is a new power lift in the Outdoor range and in terms of size it is positioned between the SL 380 Outdoor and the SL 780 Giant



The Smartlift is easily transported in a van or on a trailer

N.A. Christensensvej 39
DK-7900 Nykøbing Mors
Tel.: +45 97 72 29 11
E-mail: smart@smartlift.dk
www.smartlift.dk

Smart Lift
DENMARK

The lift has 100 mm sideshift for accurate adjustment when fitting the window



The vacuum system is separated into two vacuum circuits for highest security. Showing vacuum circuits with blue and red vacuum hoses

The yoke has movements in all directions

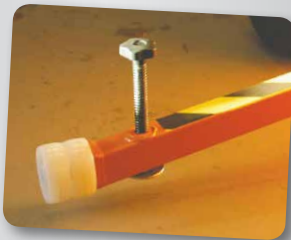

For high security the stabilizers of the lift are equipped with mandrels to fasten on stable ground for better stability.

Technical data

Description	Value
Weight	830 kg
Height	1530 mm
Width (min)	830 mm
Length (min)	2340 mm
Extension of arm	700 mm
Tip from horizontal	35° back/100° forward
Speed regulation	Stepless high/low
Sideshift	100 mm
Vacuum system	2 circuits
Lifting height mounting	3500 mm
Charging voltage	230 volt
Integrated charger	Cetek XT 14000
Charging time	Approx 8 hours
Battery(2 x 12v) 24 volt	2 x 105 A
Running period	Approx 20 hours
Front-wheel drive	1200 Watt - AC
Brake	Elektronic
Suction pads	4 unit Ø 400 mm
Lifting capacity arm in/extended (700 mm)	608 kg/280 kg

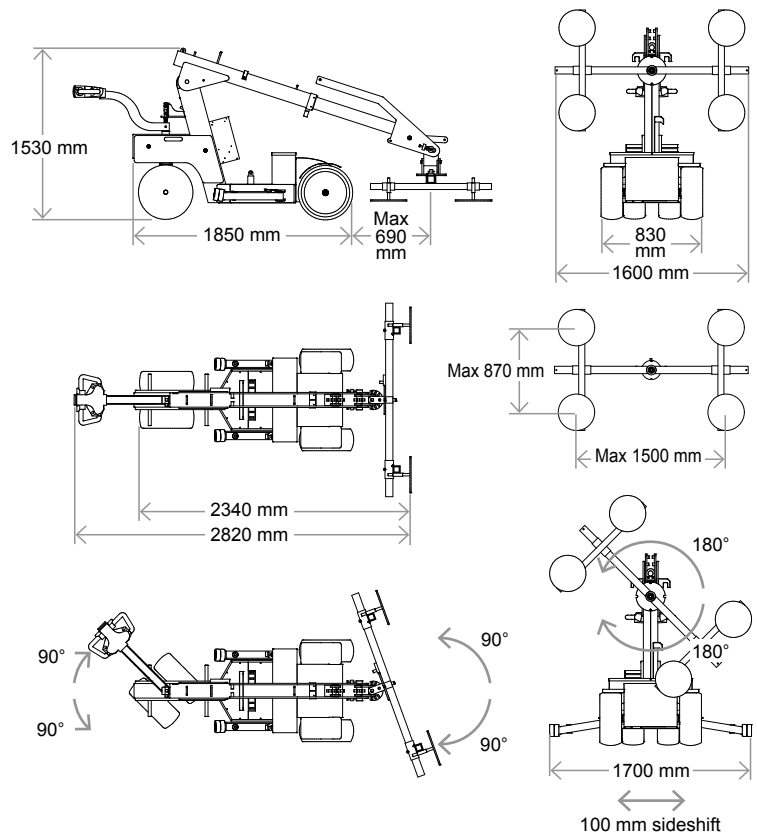
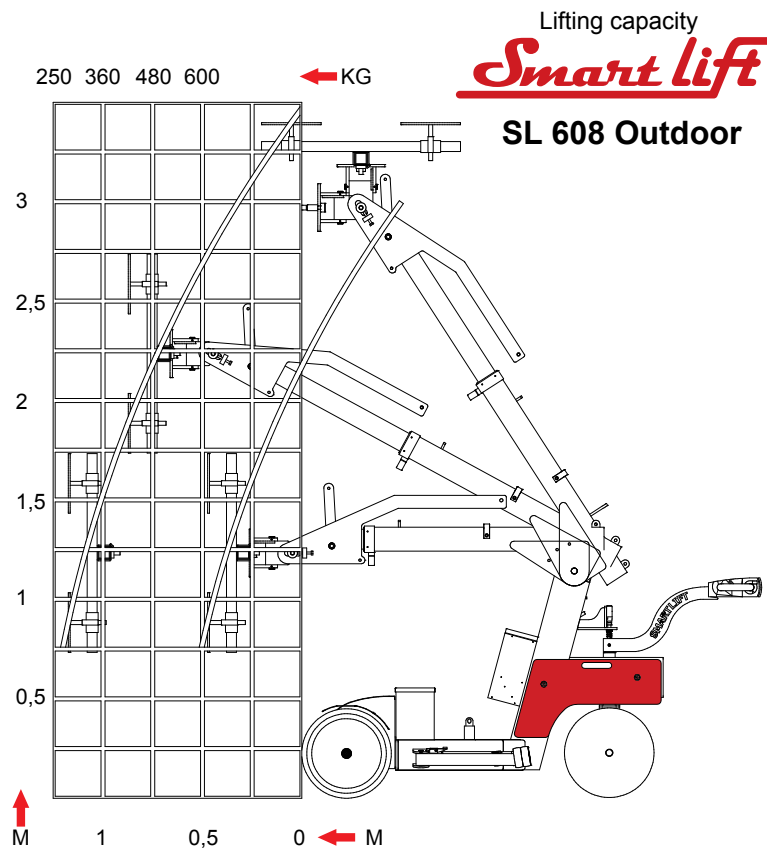

N.A. Christensensvej 39
 DK - 7900 Nykøbing Mors
 Tel.: +45 97 72 29 11
 E-mail: smart@smartlift.dk
 www.smartlift.dk