

Model 64 R Trakrane

ON & OFF THE ROAD OR RAIL –
REACHING NEW HEIGHTS
AND WORKING HARDER THAN EVER.



LITTLE *Giant*

For more than a half-century, the Little Giant Corporation has been a name synonymous with the railroad industry in producing hydraulic track cranes, rail dedicated cranes, truck mounted cranes and rough terrain material handlers. Little Giant cranes are working every day in every corner of the world and are known for their ease of maintenance and cost-effective design.



217 Patneau Drive
Winona, Minnesota 55987
Phone: (507) 454-1563
Fax: (507) 453-6441
www.littlegiantcorp.com

Model 64 R Trakrane

LOAD CHART

64R TRAKRANE LOAD CHART

Length (FT)	Load Radius (FT)	Boom Angle (°)	Distance ** (FT)	ON RAIL WHEELS		ON TIRES	
				Over End	270°	Over End	Over Side
30	10	75	2.4	50,000	-	25,000	18,000
	12	71	2.8	50,000	-	23,000	15,800
	15	65	3.5	42,500	10,600	19,500	14,100
	20	54	4.7	37,500	7,100	13,500	9,100
	25	41	6.0	26,000	5,100	10,400	6,800
	30	23	7.1	19,900	3,900	8,300	4,700
	31'-3"	15.7	7.4	18,700	3,700	6,100	3,800
35	15	69	3.5	42,500	10,600	18,900	13,800
	20	60	4.7	37,300	7,300	13,200	8,800
	25	50	6.0	26,300	5,800	10,100	6,200
	30	38	7.1	19,900	4,400	8,100	4,400
	35	21	8.3	16,200	3,100	6,500	3,500
	36'-4"	13.4	8.6	14,300	2,700	4,200	2,700
40	15	71	3.5	42,500	9,300	17,100	13,200
	20	64	4.7	36,400	6,500	12,200	8,600
	25	55	6.0	25,300	4,300	8,900	6,500
	30	46	7.1	19,400	3,300	7,100	5,000
	35	35	8.3	15,400	2,300	5,600	3,800
	40	19	9.5	12,700	1,800	4,500	3,000
	41'-6"	11.6	9.8	11,800	1,400	3,000	1,600
45	15	74	3.5	41,800	8,900	16,800	12,900
	20	67	4.7	36,000	5,800	11,600	7,200
	25	60	6.0	24,000	3,900	8,400	5,100
	30	62	7.1	19,100	2,700	8,400	3,700
	35	43	8.3	15,200	2,800	5,000	2,600
	40	33	9.5	12,600	NO LIFT	3,900	1,900
	45	18	10.6	10,900	NO LIFT	2,100	NO LIFT
50	15	75	3.5	41,200	8,600	16,400	12,600
	20	69	4.7	35,600	5,400	11,100	6,500
	25	63	6.0	24,800	3,500	8,000	4,200
	30	56	7.1	18,900	2,300	6,200	2,700
	35	49	8.3	15,100	1,100	4,600	1,500
	40	41	9.5	12,600	NO LIFT	3,400	900
	45	31	10.6	10,700	NO LIFT	1,800	NO LIFT
	50	17	11.7	9,200	NO LIFT	900	NO LIFT

ON RAIL "SUPERELEVATION"

Length (FT)	Load Radius (FT)	Boom Angle (°)	ON RAIL "SUPERELEVATION" 270° ROTATION					
			1 Inch	2 Inch	3 Inch	4 Inch	5 Inch	6 Inch
30	10	75	-	-	-	-	-	-
	12	71	-	-	-	-	-	-
	15	65	7,950	7,420	6,890	6,360	5,830	5,300
	20	54	5,325	4,970	4,615	4,260	3,905	3,550
	25	41	3,825	3,570	3,315	3,060	2,805	2,550
	30	23	2,925	2,730	2,535	2,340	2,145	1,950
35	15	69	7,875	7,350	6,825	6,300	5,775	5,250
	20	60	5,475	5,110	4,745	4,380	4,015	3,650
	25	50	4,350	4,060	3,770	3,480	3,190	2,900
	30	38	3,300	3,080	2,860	2,640	2,420	2,200
	35	21	2,325	2,170	2,015	1,860	1,705	1,550
40	15	71	6,975	6,510	6,045	5,580	5,115	4,650
	20	64	4,875	4,550	4,225	3,900	3,575	3,250
	25	55	3,225	3,010	2,795	2,580	2,365	2,150
	30	46	2,475	2,310	2,145	1,980	1,815	1,650
	35	35	1,725	1,610	1,495	1,380	1,265	1,150
40	19	1,200	1,120	1,040	960	880	800	

1. All operators and support personnel shall read and fully understand manufacturer furnished operators manual, latest applicable American National Standards Institute (ANSI) B30.5 Safety Standards for Cranes and any applicable federal, state and local safety regulations before operating machine. Crane and load rating comply with ANSI and Power Crane & Shovel Association (PCSA) standards.

2. High gantry must be fully raised and pinned in position when lifting. Pin gantry in lowered position for **OVER-THE-ROAD** travel only!

3. All ratings where shaded text appears are based on structural strength of machine. All other ratings do not exceed 75% of tipping load **"ON TIRES"** or 85% **"ON OUTRIGGERS"** and **"ON RAIL WHEELS"** with machine stable and on firm ground within 1% of grade **"ON RAIL WHEELS"**.

4. **DO NOT EXCEED** crane loading ratings. When load radius or boom angle are between listed values, use the smaller load rating. **DO NOT ATTEMPT TO TIP MACHINE TO DETERMINE ALLOWABLE LOADS.**

5. Weights of hook blocks, bucket, slings and all other load handling devices are not accounted for in the load chart. The load handling devices must be considered as part of the load.

6. Reduce ratings appropriately for wind conditions, speed of operation, soft or uneven supporting surfaces, etc.

CAUTION

IN WIND OVER 30 MPH CEASE OPERATION, POSITION BOOM AWAY FROM THE WIND AND LOWER BOOM BELOW 65°. IN WIND OVER 50 MPH, LOWER BOOM TO GROUND, OR, SECURE IN POSITION. Reduce ratings appropriately for speed of operation, soft or uneven supporting surface, etc.

7. Load ratings apply to this machine only as originally manufactured and equipped. Unauthorized modification or optional equipment may reduce load capacity. Please consult Little Giant **BEFORE** modification or use of optional equipment not covered in this chart.

8. **DO NOT LIFT** over front of machine.

9. These load ratings are for lift service only. Consult and adhere to appropriated load ratings chart for other applications (clamshell, dragline, magnet, etc.).

WARNING

NO PICK AND CARRY LOADS ON SUPERELEVATED TRACK.

10. Pick and carry load ratings are limited to 70% of "On Railwheels - Over Road" load ratings when on rail and 60% of "On Tires - Over Road" lifts when on tires. Pick and carry operations shall be made using 50' of boom or less at the lowest possible boom angle and the longest allowable load radius. Load shall be restrained from swinging and shall be positioned as close to the ground as possible over the rear along the carrier's lengthwise centerline. **DO NOT** exceed 3 MPH (5 Km/h) travel speed using smooth starts and stops. Other crane operations **SHALL NOT** be permitted when transporting a load.

11. Recommended line: Use five parts of line for maximum lifts with precise control - 5/8" 6 x 19 Class - 6 x 25 FW, PRF, RRL, XIP, IWRC Wire Rope.

PARTS OF LINE	1	2	3	4	5
MAX. HOOK LOAD	10,000	20,000	30,000	40,000	50,000

All specifications are subject to change.

12. Recommended weight: 10 Ton Hook Block (1 Sheave) = 181 lbs.
25 Ton Hook Block (2 Sheave) = 366 lbs.

13. Recommended tire size and inflation pressures: Front - 425/64R22.5 @ 120 P.S.I.
Rear - 12R22.5 @ 120 P.S.I.

WARNING

270° LIFTS ARE WITH BOOM ANGLES OF 70° OR LESS. OPERATING BOOM ABOVE 70° MAY RESULT IN STABILITY LOSS.

On Railwheels Working Area

These lines show the work areas where the above rated loads apply. **WARNING** *270° Lifts are with boom angles of 10° or less. Operating Boom above 70° may result in stability loss.

1. Distances parallel to the rear of the carrier from the railroad track centerline to the load center line. This keeps the load inside a line drawn from the center of rotation touching the rear inside edge of the rear railwheel.

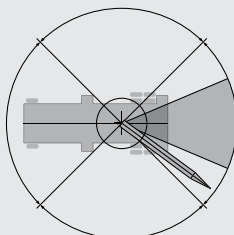

Indicated in load chart by **

On Tires Working Area

These lines show the work areas where the above rated loads apply.

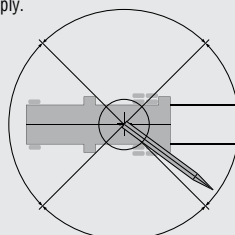

On Outriggers Working Area

These lines show the work areas where the above rated loads apply. Outrigger Lifts are with Outrigger beams fully extended and floats set to fully support and level the machine (Tires off the supporting surface) Structural support under floats may be necessary in rough terrain or to spread the load over a larger bearing surface.

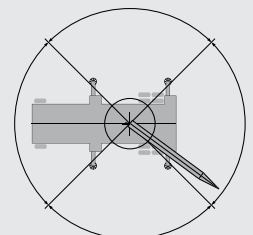

Model 64 R Trakrane

LOAD CHART

64R TRAKRANE LOAD CHART

Length (FT)	Load Radius (FT)	Boom Angle (°)	ON OUTRIGGERS			
			Over End	270°	Half Extended	Fully Retracted
30	10	75	50,000	50,000	36,400	24,800
	12	71	50,000	50,000	34,800	20,100
	15	65	47,500	47,500	26,200	13,200
	20	54	41,300	33,000	20,300	11,000
	25	41	29,200	23,100	14,900	8,400
	30	23	22,300	17,700	11,700	6,700
35	10	77	50,000	50,000	36,300	24,700
	12	74	50,000	50,000	34,100	20,000
	15	69	47,500	47,500	26,200	13,200
	20	60	41,200	32,900	20,200	11,000
	25	50	29,200	22,900	14,800	8,300
	30	38	22,100	17,500	11,600	6,700
40	15	71	47,500	47,500	26,200	13,200
	20	64	41,200	32,900	20,200	11,000
	25	55	28,900	22,900	14,700	8,300
	30	46	22,000	17,400	11,500	6,600
	35	35	17,800	13,900	9,300	5,500
	40	19	14,700	11,500	7,800	4,600
45	15	74	47,500	47,500	26,200	13,200
	20	67	41,100	32,800	20,200	11,000
	25	60	28,800	22,800	14,700	8,300
	30	52	21,900	17,300	11,500	6,600
	35	43	17,600	13,800	9,300	5,400
	40	33	14,600	11,400	7,800	4,600
50	15	75	47,500	47,500	26,200	13,200
	20	69	41,000	32,800	20,100	10,900
	25	63	28,700	22,800	14,700	8,300
	30	56	21,900	17,200	11,400	6,600
	35	49	17,500	13,700	9,200	5,400
	40	41	14,500	11,400	7,800	4,600
55	20	71	41,000	32,400	19,900	10,800
	25	66	28,600	22,600	14,600	8,200
	30	60	21,800	17,000	11,300	6,500
	35	54	17,400	13,500	9,100	5,300
	40	47	14,300	11,200	7,600	4,500
	45	39	12,200	9,300	6,400	3,800
60	20	73	40,900	32,400	19,900	10,800
	25	68	28,500	22,500	14,500	8,200
	30	62	21,700	16,900	11,200	6,500
	35	57	17,300	13,400	9,000	5,300
	40	51	14,300	11,000	7,500	4,400
	45	45	12,100	9,200	6,300	3,800
60	50	37	10,400	7,900	5,500	3,300
	55	29	9,000	6,500	4,500	2,700
	60	16	8,000	5,900	4,100	2,500

1. All operators and support personnel shall read and fully understand manufacturer furnished operator's manual, latest applicable American National Standards Institute (ANSI) Safety Standards for Cranes, and any applicable federal, state or local safety regulations before operating machine. Crane and load ratings comply with ANSI and Power Crane & Shovel Association (PCSA) Standards.

2. High gantry must be fully raised and pinned in position when lifting. Pin gantry in lowered position for **OVER-THE-ROAD** travel only!

3. All **"ON OUTRIGGER"** lifts are with outrigger beams extended to the position indicated by the chart in use and floats set to fully support and level the machine (tires off supporting surface). Additional structural blocking may be required for some applications.

4. All ratings where reversed text appears are based on structural strength of machine. All other ratings do not exceed 85% of tipping load **"ON OUTRIGGERS"** and 75% of tipping **"ON TIRES"** with machine stable on firm ground.

5. **DO NOT EXCEED** crane loading ratings. When load radius or boom angle are between listed values, use the smaller load rating. **DO NOT ATTEMPT TO TIP MACHINE TO DETERMINE ALLOWABLE LOADS.**

6. Weights of hook blocks, bucket, slings and all other load handling devices are not accounted for in the load chart. The load handling devices must be considered as part of the load.

7. Reduce ratings appropriately for wind conditions, speed of operation, soft or uneven supporting surfaces, etc.

CAUTION

IN WIND OVER 30 MPH CEASE OPERATION, POSITION BOOM AWAY FROM THE WIND AND LOWER BOOM BELOW 65°. IN WIND OVER 50 MPH, LOWER BOOM TO GROUND, OR, SECURE IN POSITION. Reduce ratings appropriately for speed of operation, soft or uneven supporting surface, etc.

8. Load ratings apply to this machine only as originally manufactured and equipped. Unauthorized modification or optional equipment may reduce load capacity. Please consult Little Giant **BEFORE** modification or use of optional equipment not covered in this chart.

9. **DO NOT LIFT** over front of machine.

10. These load ratings are for lift service only. Consult and adhere to appropriated load ratings chart for other applications (clamshell, dragline, magnet, etc.).

WARNING

Pick and carry load ratings are limited to 60% of "ON TIRES - OVER REAR" lifts. Pick and carry operations shall be made using 50' of boom, or less, at the lowest possible boom angle.

11. Load shall be restrained from swinging and shall be positioned as close to the ground as possible over the rear along the carrier's lengthwise centerline. **DO NOT** exceed 3 MPH (5 M/h) travel speed using smooth starts and stops. Other crane operations **SHALL NOT** be permitted when transporting a load.

12. Recommended tire size and inflation pressures are: Front - 425/64R22.5 @ 120 P.S.I. Rear - 12R22.5 @ 120 P.S.I.

13. Recommended weight: 10 Ton Hook Block (1 Sheave) = 181 lbs. - 25 Ton Hook Block (2 Sheave) = 366 lbs.

14. Recommended line: Use five parts of line for maximum lifts with precise control - 5/8" 6 x 19 Class - 6 x 25 FW, PRF, RRL, XIP, IWRC Wire Rope.

PARTS OF LINE	1	2	3	4	5
MAX. HOOK LOAD	10,000	20,000	30,000	40,000	50,000

All specifications are subject to change.

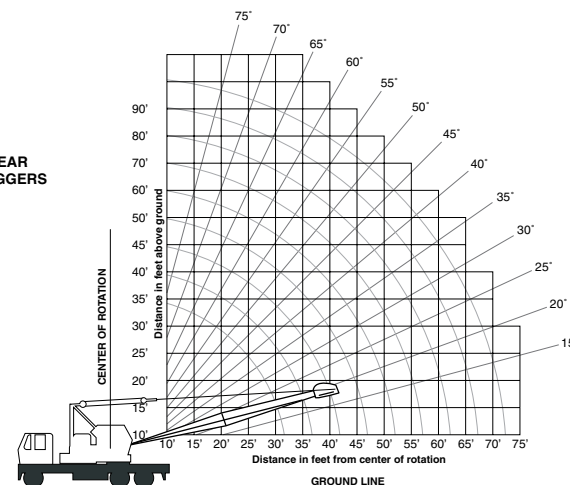
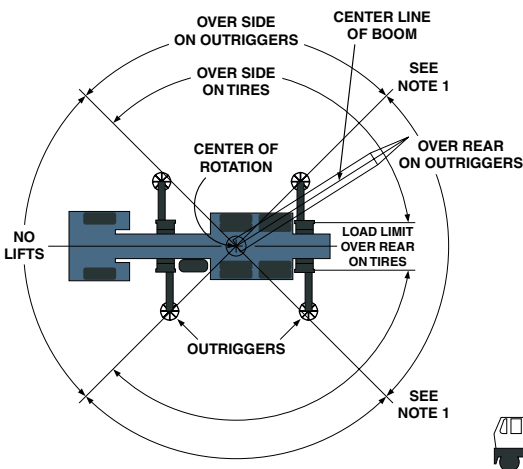

217 Patneau Drive
Winona, Minnesota 55987
Phone: (507) 454-1563
Fax: (507) 453-6441
www.littlegiantcorp.com

Model 64 R Trakrane

SPECIFICATIONS

Want a crane that's rugged with long-lasting durability? How about a 25-ton truck-mounted lattice boom crane proven in the field to be a powerful, multi-purpose Hi Rail or highway crane.

The model 64R Trakrane has two powerful Cummins diesel Tier III engines, a heavy-duty custom built carrier frame, and a full upper Little Giant lattice boom crane. Customize the crane from a variety of available options, and the 64R Trakrane will be ready to give you years and years of dedicated rail service.

- F.R.A. compliant
- Easy to operate
- Can be custom painted to match your fleet colors
- Can be rebuilt or remanufactured by Little Giant

UPPER SPECIFICATIONS

ENGINE

- Cummins QSB-4.5-Tier 3
- 160 HP (119kw) @ 2,200 RPM
- 460 lb/ft torque (624Nm) @ 1,500 RPM

MASTER CLUTCH

Disconnected Clutch for Cold Weather Starting

MAIN DRIVE

Variable Speed, Hydraulically Controlled

TURNTABLE

Ball Bearing, Single Row, bolted to Upper Structure and Carrier for Easy Removal

CONTROLS

Air, Variable Control, Adjustable for Self-Centering or Lock-In Operation

THROTTLE

Variable Speed, Hand - Optional Foot Throttle

SWING SPEED

5 RPM

LINE SPEED

198 FPM

LINE PULL

13,000 lbs. with 12" Drum

DRUM CLUTCHES

Two Shoe, Internal Expanding, Air Operated, 21-3/4" Dia. x 3" Wide

DRUM BRAKES

External Contracting, Band Type, 25" Dia. x 4" Wide

POWER LOAD LOWERING

Both Drums

BOOM HOIST

Power Up & Power Down, independent of ALL other functions

GANTRY

Folding High Gantry

STANDARD FEATURES

Telescopic Boom Backstops, Automatic Boom Hoist Kickout, Free Fall Winch, Boom Angle Indicator, Pendant Cable Suspension, Signal Horn, Tool Box, Fire Extinguisher, Anti-Two Block Warning, Triple Sheave Boom Point

OPTIONAL

Third Drum, Boom Point Fairlead, Magnet Equipment, Crane Hook Readout Systems

CARRIER SPECIFICATIONS

GVWR

68,000 lbs. Capacity

BASIC WEIGHT

Total machine weight with boom foot section, boom tip section and 175 lb. operator: 63,600 lbs.

FRAME

18" High Strength WF Beam

ENGINE

- Cummins QSC-8.3-Tier 3
- 250 HP (194kw) @ 2,200 RPM
- Peak Torque 675 lb/ft (915Nm) @ 1,300 RPM

COOLING SYSTEM

Coolant Capacity - 33 qt., Centrifugal Pump, Belt Driven, Fin & Tube Radiator, Anti-Freeze

ELECTRICAL

12 Volt with 100 Amp Alternator, Heavy Duty Battery, Head Lights, Parking Lights, Combination Stop & Tail Lights, Horn, Turning Signals, 4-Way Flasher, Dome Light, 2-Speed Electric Windshield Wiper

TRANSMISSION

Allison SP3500, 6-Speed Automatic with Torque Converter

AUXILIARY TRANSMISSION

Franklin, Full-Reversing
Ratios: 1.71 - 1 Low, 1 - High

FRONT AXLE

Eaton EFA-22T5, 20,000 lb. Capacity

REAR AXLE

Eaton DS46-170P, 46,000 lb. Rating, Single Reduction, Internal Differential,

Cab Controlled Differential Lockout on Intermediate Axle

SUSPENSION FRONT

Semi-Elliptic, Alloy Steel Leaf, 3" Wide x 52-3/4" Long, 9 Leaves per Spring with 5 Leaf Auxiliary Spring

SUSPENSION REAR

Little Giant, Hendrickson Type, Includes Torque Rods and Equalizer Beams

BRAKES

Service: Air, All Wheels
Parking: Spring Loaded, Both Rear Axles
Digging: Both Rear Axles, Dash Mounted Control
Lining: Rear - 16-1/2" x 7, Front - 16-1/2" x 6 All 'S' Cam

WHEELS / TIRES

Budd, 10- Hole Disc Type
Rear: 12R22.5 H, Dual Wheels
Front: 425/65R22.5 L, Single

STEERING

Full Power Steering - TRW Model TAS85

OPTIONAL

Storage-Type Running Boards, Remote Control, Backup Alarm, Windshield Washer, Spare Wheel & Tire, 6x6 Carrier, Car Couplers, In Train Air Supply, Auxiliary Air Supply (for Air Dump Cars), Runway Decking, Special Paint, Hydraulic Outriggers



All specifications are subject to change.



217 Patneau Drive
Winona, Minnesota 55987
Phone: (507) 454-1563
Fax: (507) 453-6441
www.littlegiantcorp.com

Model 64 R Trakrane

GENERAL DIMENSIONS

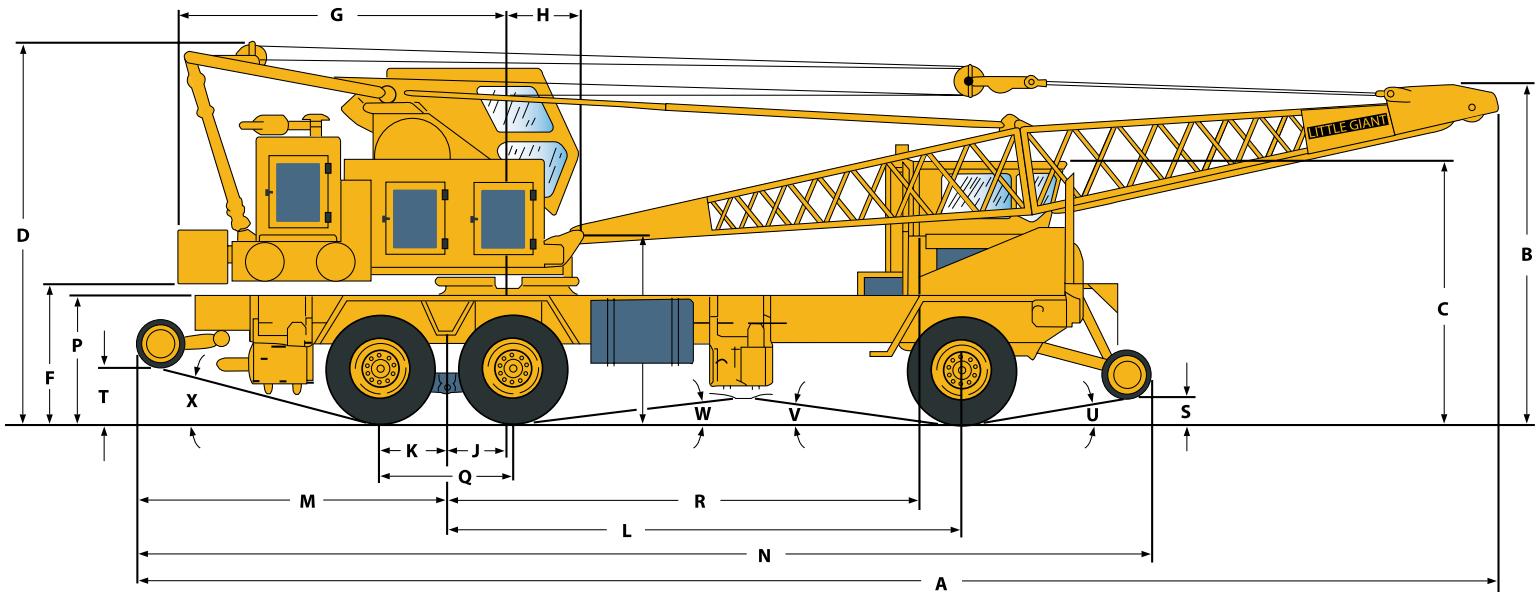

Description	U.S.	Metric
A Overall length with 30' Boom	44' 11"	13.69m
B Height of Boom in Travel Position	11' 7"	3.53m
C Maximum Height of Carrier Cab Above Grade	9' 1"	2.77m
D Maximum Travel Height	12' 8"	3.86m
E Maximum Height with Raised Gantry	15' 8"	4.78m
F Distance Under Counterweight to Grade	4' 8"	1.42m
G Maximum Swing Clearance	10' 10"	3.30m
H Boom Foot Pin to Center of Rotation	2' 4"	.71m
I Height of Boom Foot Pin Above Grade	6' 3"	1.91m
J Bogie Center to Center of Rotation	2' 0"	.61m
K Rear Tandem to Bogie Center	2' 2"	.66m
L Front Axle Center to Bogie Center	17' 0"	5.18m

Description	U.S.	Metric
M Bogie Center to Rear Extreme	12' 0"	3.05m
N Carrier Length	34' 6"	10.52m
O Overall Width for Travel (not shown)	8' 0"	2.44m
P Height to Carrier Deck	4' 3"	1.30m
Q Tandem Centers	4' 4"	1.32m
R Cab Rear to Bogie Center	15' 11"	4.85m
S Front Railwheel Road Clearance	1' 0"	.30m
T Rear Railwheel Road Clearance	1' 8"	.51m
U Angle of Approach	11°	
V Angle of Interference	8°	
W Angle of Interference	7°	
X Angle of Departure	13°	
Y ** Weight	63,600 lbs.	28848 kg

All specifications are subject to change.

**Overall weight of machine with boom foot section, boom tip section and 175 lb. operator: 63,600 lbs.

OPTIONS FOR MODEL 64R TRAKRANE

Model 64R Truck Mounted 25-Ton Crane with Rail Gear and a 160 HP Cummins QSB-4.5-Tier 3 Engine

- 5' Boom Extension w/Pendent Cables
- 10' Boom Extension w/Pendant Cables
- 20' Boom Extension w/ Pendant Cables
- Full Revolving Fairlead
- Boom Tip Fairlead
- LSI Load Moment System
- A-2-B Load Monitor
- Drum Rotation Indicators (both drums)
- Anti-Vandal Kit for Carrier and Upper
- Allison Automatic Transmission (model RDS3500)
- 6X6 Carrier Drive (manual transmission only)
- Spare Tire (ea.)
- Axle Differential Lock - Driver Controlled
- 10-Ton Hook Block (1 Sheave)
- 25-Ton Hook Block (2 sheave)
- 3rd Drum Winch (hydraulic drive)
- Air Conditioner - Upper Cab
- Air Conditioner - Carrier Cab
- Tagline - Single Barrel
- Outrigger - Out & Down Cab Controlled
- Electro- Magnet 10KW Generator w/Tagline & Controls
- 40" Magnet
- 1/2 Yard Clam Bucket
- 5/8 Yard Dragline Bucket
- 1 Yard Dragline Bucket
- Air Car Dump

NOTE: For Clamshell and Dragline applications you will need to order a Revolving Fairlead, Boom Tip Fairlead, and a Tagline.



Little Giant Corporation is a Division of Manitex International, Inc.



217 Patneau Drive
Winona, Minnesota 55987
Phone: (507) 454-1563
Fax: (507) 453-6441
www.littlegiantcorp.com