

P&H[®] ΩMEGA-S-20

20 ton High Speed All Terrain Crane 110 ft (33.5M) Maximum Tip Height



The Omega All-Terrain Crane offers the best of both truck and Rough-Terrain Cranes without their limitations —

- **Highway speeds to 47.6 mph (76.7 kph).** Powershift transmission provides 6 forward and 3 reverse ranges.
- **Equal weight distribution** for low, legal axle loads.
- **Four wheel drive and large tires** meet most traction and ground pressure requirements.
- **Fully sprung suspension** permits comfortable ride — axles have lockouts for pick and carry operation.
- **Turbocharged engine** offers low sound levels, low fuel consumption, excellent high altitude performance and superior torque for optimum horsepower usage.
- **Superior lifting performance** provided by rectangular full depth four-plate OMEGA boom that is welded inside and out.
- **Excellent reach** afforded by telescoping 81'5" (24.81 m) 4 section boom. Add 22' (6.7 m) lattice boom extension for total length of 103'5" (31.51 m).
- **Total operator comfort** means less fatigue and greater production. Spacious cab module allows placement of controls "in the palm of your hand", lots of leg and elbow room, and full vision of all activities.
- **Less downtime** — OMEGA is "Pit-Stop" maintenance-proven. It's industry's most serviceable crane — engineered for parts commonality, accessibility and tear-down.

Specifications

specifications

BOOM



BOOM: All boom sections are of full depth rectangular four-plate construction welded inside and out, with adjustable nylon-slider pads on top, bottom and sides. All powered sections are single lever controlled. Boom has capacity to telescope rated loads. Boom point contains four 1 1/2" (289 mm) P.D. main sheaves and one 1 1/2" (289 mm) P.D. idler sheaves. Sheaves are non-metallic with roller bearings.

Four (4) section boom, with manual section, 27.4' (8.35 m) retracted length, 81.4' (24.81 m) extended length, consisting of one base section, 2 powered sections and one manual extended and retracted section with boom point.

BOOM EXTENSION (OPTIONAL): 21.98' (6.70 m) swing-around tapered lattice structure with single 12" (303 mm) P.D. non-metallic boom point sheave with roller bearing. Easily installed from ground level by pivoting from its stored position on right side of boom base and pin connecting to boom point. For extending reach of boom.

HOOK BLOCKS (OPTIONAL):

- 5 Ton — weighted hook with swivel and safety latch, for 1/2" (13 mm) wire rope.
- 10 Ton — Single sheave with swivel hook and safety latch, for 1/2" (13 mm) wire rope.
- 15 Ton — 2 sheave with swivel hook and safety latch, for 1/2" (13 mm) wire rope.
- 20 Ton — 3 sheave with swivel hook and safety latch, for 1/2" (13 mm) wire rope.

COUNTERWEIGHT: 2,600 lb. (1180 kg) standard, 1,500 lb. (680 kg) is optional.

Overload device: Electronic load moment device available with shut down valves and hoist limit switches.

UPPERSTRUCTURE



OPERATOR'S CAB: All-weather environmental cab of steel has hinged ceiling window, slide-by right side window with guard, locking slide-by door and large windows with full view in all directions. Safety glass used throughout. Operator's four-way adjustable seat is hydraulically cushioned. Cab is 34.5 inches (876 mm) wide with a stand-up height of 56 inches (1422 mm) and is cushion-mounted for vibration dampening and noise reduction.

CAB ACCESSORIES (STANDARD): Cab contains all roading and crane function controls in addition to electric remote control of outriggers, and foot-operated upper parking brake.

CAB ACCESSORIES (OPTIONAL): Heater (diesel fueled, thermostatically controlled), defroster fan, electric roof window wiper, seat belt, fire extinguisher, mechanical or electronic boom angle indicator, electric boom length indicator, electric load indicating device, drum rotation indicator for main winch, electric warning horn, windshield wiper, windshield washer, air conditioner, amber rotating beacon, and boom light.

Control and Instruments: Operating levers to left of operator: swing, boom telescope; levers to right: main winch normal speed, main winch slow speed (both combined for high speed), boom hoist. Foot pedals: boom hoist, upper parking brake, travel service brake, engine accelerator.

The instrument panel is fitted with the following: brake, air pressure gauge, remote thermometer for hydraulic oil; one collective control lamp to indicate: torque converter oil pressure, torque converter temperature, engine oil pressure, engine temperature, V-belt rupture and generator charging current. Control lamp for brakes applied by means of spring activated cylinders. Switches used for axle lockouts, all-wheel drive, all-wheel crab steer, engine start, engine stop, all outrigger operations, windshield wiper (front window), cab dome light.



VOLU-MATIK® HYDRAULIC SYSTEM: Designed to provide ample volume and pressure for optimum performance.

Pumps: Two tandem gear pumps mounted on powershift transmission but driven directly by engine through gearing. Can be disengaged for highway travel. Total hydraulic flow of 158 GPM (600 LPM). 2 sections for 3-speed winch, 1 section for swing and outriggers, and 1 section for hoist and telescope. Steering and oil cooler fan functions controlled by engine mounted tandem gear pump delivering 29 GPM (111 LPM).

Reservoir: 90 gal. (340 l) capacity, mounted on the right side of the carrier frame between the front and rear wheels.

Oil cooler: Combined air/oil cooler for hydraulic and torque converter oil, separate fan drive with hydraulic motor. Accommodates flow up to 18.6 GPM (176 LPM).

Filter: Return filters designed for full return flow: 10 microns.

Control valves: 1 double and 3 single, low-effort control valves operated by low friction push-pull cables. Solenoid valves used for outrigger operation and steering from upper cab. Lowering brake valve for winch control. Holding valves on boom hoist and telescope cylinders. Sheet metal cover for valves and piping is optional.

Boom hoist: One 10.0" (255 mm) diameter double acting cylinder with holding valve.

Boom telescope: One double acting, two stage telescoping cylinder with 5.51" (140 mm) diameter bore for first section, 4.33" (110 mm) diameter bore for second section.



MAIN WINCH: Braden Model PD12A 3-speed, mounted on rear of upper. Planetary gearing with equal speed power raising and lowering. Infinitely variable controlled speed. Spring applied, hydraulically released load holding multiple disc brake is automatic. Complete with 400' (122 m) wire rope.

Drum: 9.625" (24.4 cm) P.D. x 13.75" (34.9 cm) wide with 16.25" (41.3 cm) dia. flanges.

Wire Rope: 1/2" (13 mm) dia. 8 x 19 spin resistant with 7 x 7 I.W.R.C.

Drum Capacity: 535 ft. (163m) 6 layers.

Line Pull (Max): 9250 lb. (4196 kg) 1st layer.

Line Pull (Permissible): 6,000 lb. (2721 kg) per part of line.

Line Speed Up (Max.):

Slow speed	140 fpm (43 m/m)	5th layer.
Medium Speed	216 fpm (66 m/m)	5th layer.
High speed	320 fpm (98 m/m)	5th layer.



Swing unit: Hydraulic motor driving through double reduction planetary gearing. 360 degree continuous rotation at 3.5 RPM.

Swing gear: Upper machine and carrier, connected with single row roller bearing with external teeth. Pitch diameter of 39.89" (1008 mm).

Swing brake: Foot pedal operated disk brake. Locked by stop valve and released by hand lever. The swing brake is not a decelerating brake, but a parking brake for the upper.

HOUSE LOCK: Two position (front and rear) pin-in-hole lock manually engaged with house lock lever in cab.

ROTARY MANIFOLD: Sealed rotary swivel for hydraulic hose connections between rotating upper and carrier. Quickly removable from above or below for servicing. Electrical swivel is mounted on top of hydraulic swivel.

CARRIER



CARRIER: Harnischfeger-built 4 x 4 x 4 (four-wheel drive, four-wheel steer).

FRAME: All-welded unitized construction assures rigidity and permanent alignment of swing bearing and rotating upper machinery. Fabricated box construction main frame beams of high strength alloy steel and reinforced with box cross members of high strength alloy steel.



HYDRAULIC OUTRIGGERS: Four (4) independent assemblies that hydraulically extend out horizontally from carrier frame and down vertically to form a stable working platform. Four (4) double acting hydraulic cylinders provide independent horizontal beam movement and four (4) provide vertical rod movement. Vertical cylinders are equipped with holding valves. Cylinders are actuated by electric solenoid directional control valves operated from cab console switches.

OUTRIGGER BEAMS: Fabricated high strength alloy steel box extending to a maximum of 8'2.75" (2.51 m) from center of carrier.

OUTRIGGER FLOATS: Removable floats with storage on carrier deck. Float size 14" (356 mm) square.



CAB: Low profile environmental cab of steel construction is mounted forward of the front suspension on the carrier frame. Cab is cushion mounted for vibration dampening and noise reduction. Large safety glass windows are used throughout, providing full view in all directions. Operators four-way adjustable seat has torsion suspension.

Controls and Instruments: Air pressure gauge, remote thermometer for engine and torque converter oil temperature, fuel gauge, tachometer, speedometer, hour meter, oil pressure gauge for clutch pressure of powershift transmission. Switches for: emergency flasher, glow plug starter, turn signal and high beam, parking lights, axle lockout, all-wheel drive, dome light. Control lamps for: differential brake pressure warning, generator charging current, engine oil pressure, high beam, all-wheel drive, flashers, V-belt rupture, maxi-brake, steering pump, air pressure, engine preheating, engine stop device.

Carrier equipment (standard): Windshield wiper and washer, 2 rear view mirrors, head lights, tail lights, stop lights, front rear and side flashers, license plate light, anti-collision light, front and rear bumpers, fenders and non-skid cover, rear hook block attachment, pullout battery rack, tool box.

Carrier equipment (optional): Rotating beacon, diesel fueled heater, heating system, fire extinguisher, back-up light, fog tail light, spare wheel assembly, front and rear towing hook.



POWER PLANT

ENGINE

Model	Deutz Model BF6L-913
Type	Diesel - direct injection
No. of cylinders	6
Cycle	4
Bore x Stroke, in. (mm)	4.02 x 4.92 (102 x 125)
Displacement, cu. in.	373.5
Liters	6.12
Air Induction	Turbo-charged
Air Cleaner	2-stage dry type - replaceable element
Oil Filter	Fullflow with replaceable element
Fuel Filter	Fullflow with replaceable element
Fuel Tank	63.4 gal. (240 liters) FHWA approved (Left side of carrier)
Cooling	Air - 3,389 CFM air flow
Starting	24 volt motor

Charging	24 volt alternator, negative ground
Batteries	Two-110 amp. hour each - 12 volts
Compressor, air	12 CFM @ 1250 RPM
Governor, air	105-120 PSI
Horsepower, Gross	157 (117 Kilowatts @ 2500 RPM)

Transmission: ZF powershift transmission 6 WG 120 with 6 forward and 3 reverse ranges. Equipment with sprag clutch in torque converter for engine assisted braking operation with moving machine. Shifting electrically controlled, hydraulically operated.

Axles:

Front axle: Driven, steered ZP planetary axle with reduction of 13.4:1. Front axle is disconnected automatically for highway travel when transmission is in high range (4th forward gear).

Rear axle: Driven, steered ZP planetary axle with reduction of 13.4:1

Suspension: Both axles are suspended on parabolic 4-leaf springs and equipped with hydraulic shock absorbers for high speed travel. Shock absorbers have air actuated lockouts to eliminate spring suspension for on-rubber crane operation and rough terrain operation.

Brakes: Service brakes consist of dual circuit, air-assisted system working on all wheels. Brakes are disc-type. Hand and parking brake act as maxi-brake on a brake drum on transmission.

Wheels and tires: Sheet metal 10.0 x 24 disc wheels. Tires Std. 14.00 x 24, 18 PR, road and rough terrain SRL tread. Opt. 17.5 x 25, 20 PR, XLB Two Star.

Steering: From carrier cab steering is mechanically operated with hydraulic assist by steering cylinder, type ZF-halfblock. Steering from upper cab is fully hydraulic. Removal of steering wheel from either cab automatically locks out that respective steering system. 4 x 4 x 4 drive/steer configuration allows for 4-wheel and crab steering, actuated through electric switches in upper cab.



PERFORMANCE: Six (6) forward speeds, 3 reverse speeds. Performance in highest and lowest gear based on engine at full load rpm, 40,000 lb. gross vehicle weight, 14:00 x 24 tires, and good surface road. Maximum grade is under ideal conditions and limited by tire slip — 50%.

Low Range Speeds

1st	5.5 mph (8.9 Kmph)
2nd	7.9 mph (12.7 Kmph)
3rd	12.6 mph (20.3 Kmph)

High Range Speeds

4th	19.9 mph (32.0 Kmph)
5th	30.3 mph (48.8 Kmph)
6th	47.6 mph (76.7 Kmph)



Axle Loads: Vehicle weight includes standard engine boom over rear in travel position, 3 speed winch with cable, 14.00 x 24 tires and 2600 lb. counterweight.

	G.V.W.	Front Axle	Rear Axle
	40,046 (18,137 kg)	21,188 (9596 kg)	18,858 (8541 kg)
Effect on axle loads by adding or removing these items —			
Deduct of 2600 lb. Counterweight	2600 (1180 kg)	-4031 (-1826 kg)	+1426 (+646 kg)
Add 1500 lb. Counterweight (this replaces 2,600 lb. Counterweight — it is not an add on)	1500 (680 kg)	+2413 (+1093 kg)	-913 (-413 kg)
Boom Extension (stowed)	378 (171 kg)	-124 (-56 kg)	+502 (+227 kg)
20 Ton Hook Block	485 (220 kg)	-428 (-194 kg)	+913 (+414 kg)
10 Ton Hook Block	198 (90 kg)	-174 (-80 kg)	+372 (+169 kg)
Spare wheel & tire 14:00 x 24	540 (245 kg)	-280 (-127 kg)	+820 (+372 kg)
Spare wheel & tire 17:50 x 25	583 (264 kg)	-300 (-136 kg)	+883 (+400 kg)

general dimensions

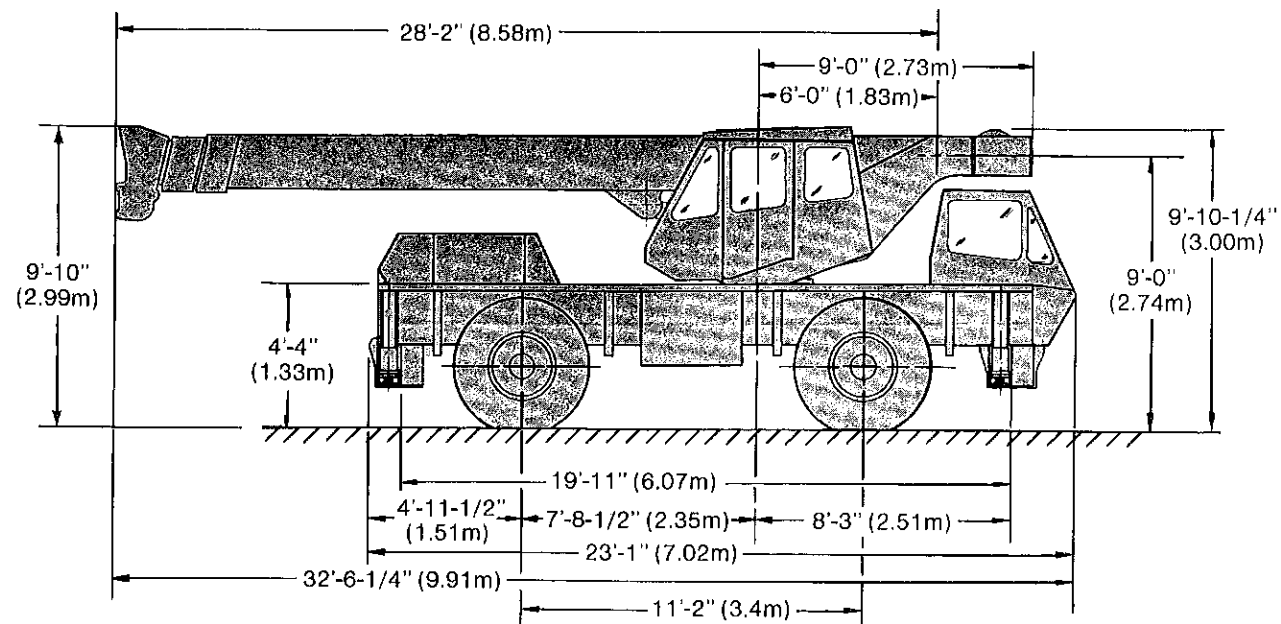

DIMENSIONS ARE WITH STD. TIRE SIZE - 14.00 x 24

VEHICLE TURNING DIAMETER	TIRES
14.00 x 24	
- 4-WHEEL STEERING CRAMP.	39'6" (12.05 m)
- FRONT AXLE STEER	68'0" (20.7 m)

VEHICLE CLEARANCE DIAMETER	TIRES
14.00 x 24	
- 4-WHEEL STEER CRAMP	54'5" (16.6 m)
- FRONT AXLE STEER	75'7" (22.89 m)

VEHICLE TURNING DIAMETER	TIRES
17.5 x 25	
- 4-WHEEL STEER CRAMP	39'8" (12.15 m)
- FRONT AXLE STEER	68'3" (20.82 m)

VEHICLE CLEARANCE DIAMETER	TIRES
17.5 x 25	
- 4-WHEEL STEER CRAMP	54'5" (16.6 m)
- FRONT AXLE STEER	75'7" (22.89 m)

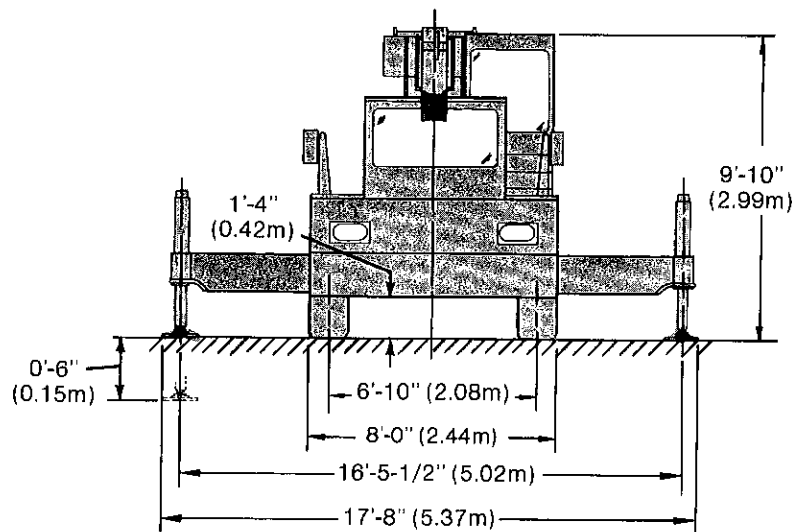

22105J124

Hoist reeving for boom-operation							
parts of line	1	2	3	4	5	6	7
max. load in kgs.	2 720	5 440	8 160	10 890	13 680	16 330	18 140
max. load in lbs.	6 000	12 000	18 000	24 000	30 000	36 000	40 000

operating instructions

This P&H crane meets the requirements of ANSI B30.15 (1973). Boom structure (boom and lattice extension) has been tested per SAE J1063, machine stability tested per SAE J765. LOAD RATINGS shown apply only to machine as originally manufactured and equipped by Harnischfeger Corporation.

WARNING: Operation of this machine in excess of rated loads, in areas of chart not rated, or with disregard of instructions voids this warranty.

- LOAD RADIUS is horizontal distance from axis of rotation (before loading) to center of vertical hoist line (after loading). Actual working radii should be an accurate measurement.
- Boom and lattice extension point height dimensions are measured from ground to center of load sheave.
- LOADED BOOM ANGLE is the angle between the boom base section and the horizontal axis after lifting rated load at rated radius. Loaded boom angles shown are with rated loads applied and provide an approximation of the LOAD RADIUS at the specified BOOM LENGTH (includes lattice extension). The boom angle before loading should be slightly greater to account for boom deflection.
- LOAD RATINGS shown are for machine with counterweight as shown, leveled and standing on firm, uniform supporting surface. Ratings are based on freely suspended loads and are not more than 85% of minimum tipping loads. Ratings above the bold horizontal line are based on machine's hydraulic or structural competence and not on machine stability (tipping conditions).
- To determine LOAD RATINGS in-between those shown on chart, proceed as follows:
 - for boom lengths not shown, use rating of next longer rated boom;
 - for load radii not shown, use rating of next longer rated radius.
- Deduct weight from LOAD RATINGS of all suspended load handling devices such as hooks, hookblocks, slings, buckets, etc. as they are considered part of the load. See table for deductions.

- Deduct weight from LOAD RATINGS of fixed boom attachments (boom extension) either stowed or erected, as they reduce capacity of boom. See table for deductions.
- LOAD RATINGS shown make no allowance for such factors as wind effect on lifted loads, ground conditions, out-of-level, operating speed or conditions that could be detrimental to safe operation of this machine. The operator must judge these factors and reduce ratings accordingly.
- "ON OUTRIGGERS" LOAD RATINGS are based on outriggers fully extended and set at a distance of 8 ft. 2.75 in. (2.51 m) from longitudinal axis of carrier to vertical axis of outrigger float. Machine must be level and supported by outriggers with tires free of supporting surface.
- "ON TIRES" LOAD RATINGS are based on lift limitations and conditions of tires inflated to pressures shown in table, and apply only when axle lockouts are engaged. "Travel" ratings are limited to travel speed less than 1.2 mph on firm, level ground with load centered over front of machine and load restrained from swinging.
- Each section of telescoping boom is extendible a distance of 18 feet (5.49 m).
- The maximum load which may be telescoped is limited by hydraulic pressure, boom angle and lubrication. It is safe to telescope any load within limits of load rating chart.

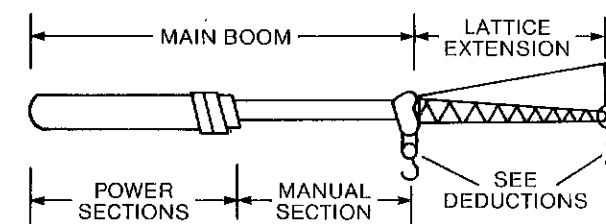

areas of operation

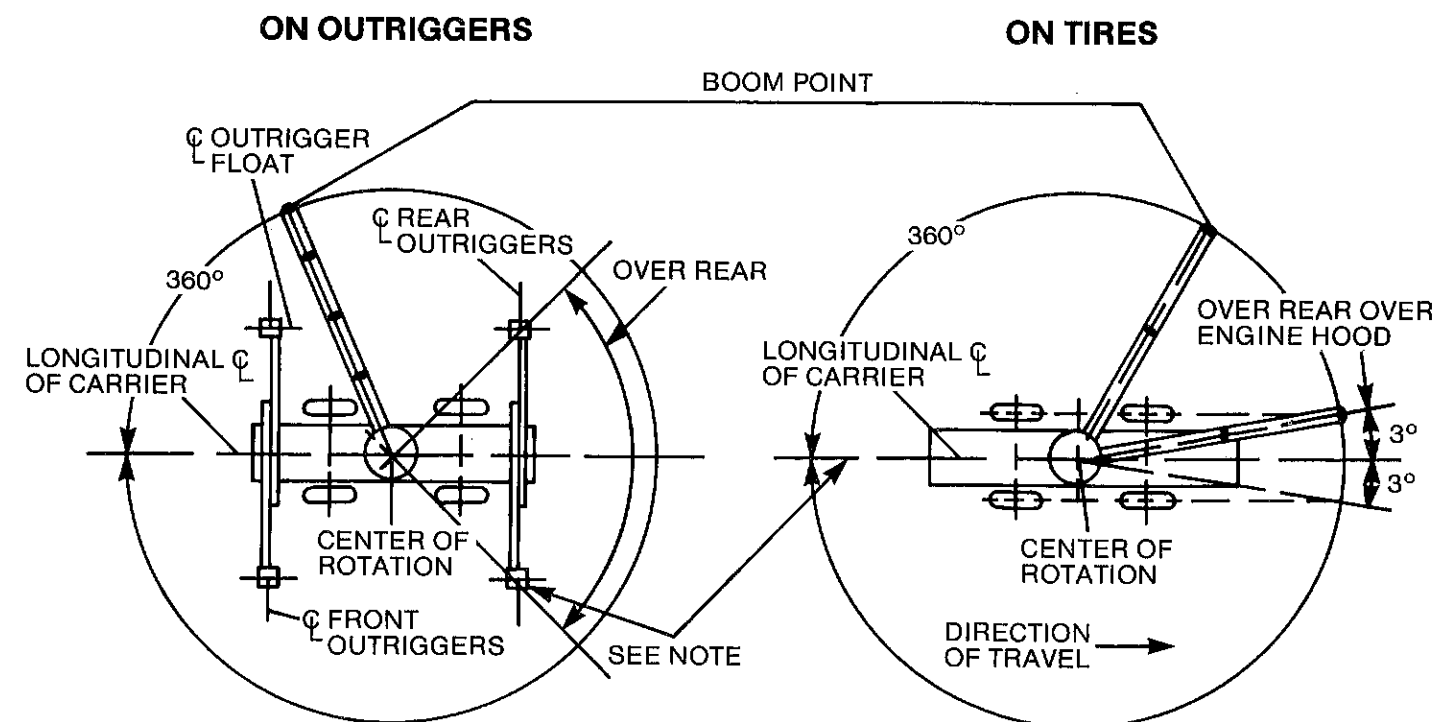

NOTE
THESE LINES DETERMINE THE LIMITING POSITION OF ANY LOAD FOR OPERATION WITHIN WORKING AREAS INDICATED.

Deductions to be made from powered crane load ratings (pounds) equipped with		
stowed lattice extension	erected lattice extension	
180	705	
20 Ton — 3 sheave hook block		500
15 Ton — 2 sheave hook block		400
10 Ton — 1 sheave hook block		325
5 Ton — ball hook		105

TO HELP PREVENT TIPPING CONDITIONS WHEN "LIFTING ON TIRES", IT IS RECOMMENDED THAT —

1. MINIMUM BOOM LENGTHS BE USED, NOT EXCEEDING 45.4 FEET
2. OUTRIGGERS BE EXTENDED AS FAR AS POSSIBLE AND CLEAR OF GROUND

LOAD RATINGS DEPEND ON TIRE CAPACITY AND CONDITION INFLATED PER TABLE AND APPLY ONLY WHEN AXLE LOCKOUTS ARE ENGAGED.

TIRE INFLATION (PSI)			
SIZE	STAT	CREEP	ROADING
14.00 x 24 PR18	95	90	85
17.5 x 25 PR20	95	95	95

WHEN TRANSPORTING A LOAD, MACHINE MUST BE ON FIRM, LEVEL SURFACE WITH MECHANICAL HOUSELOCK ENGAGED AND LOAD CENTERED OVER REAR OF MACHINE AND RESTRAINED FROM SWINGING. CREEP IS MOTION FOR LESS THAN 200 FT. (60.9 M) IN A 30 MIN. PERIOD AND NOT EXCEEDING 1 MPH.

WARNING: LIFTS ON TIRES WITH LATTICE EXTENSION IN WORKING POSITION ARE PROHIBITED.

PCSA CLASS 10-56

Crane boom with manual section and lattice extension
Rated crane loads in pounds — boom in 360° and over rear work areas
With outriggers fully extended and set — 1500 lbs. counterweight

BOOM LENGTH									
MANUAL SECTION RETRACTED									
		27.4		45.3		63.3			
LOAD RADIUS (FEET)	LOADED BOOM ANGLE Δ°	RATED LOAD POUNDS		LOADED BOOM ANGLE Δ°	RATED LOAD POUNDS		LOADED BOOM ANGLE Δ°	RATED LOAD POUNDS	
		360°	REAR		360°	REAR		360°	REAR
10	57	40000	40000	71	28700	28700			
12	52	31300	31300	68	27700	27700			
15	43	24300	24300	64	23800	23800	72	17400	17400
20	21	17500	17500	57	17000	17000	67	15900	15900
25				49	13000	13000	62	13100	13100
30				39	9000	9900	57	9700	10000
35				27	6600	8000	51	7200	7800
40							45	5600	7000
45							38	4300	5800
50							29	3400	4800
55							17	2700	4000
60									
65									
70									

FOR 27.4' BOOM RATINGS TELESCOPE CYLINDERS MUST BE FULLY RETRACTED AND AGAINST STOPS

RATINGS ABOVE THE HEAVY LINE ARE BASED ON STRUCTURAL COMPETENCE AND NOT ON MACHINE STABILITY

MANUAL SECTION EXTENDED			
LOAD RADIUS (FEET) FOR 81.40 FOOT BOOM ONLY	FOR ALL BOOM LENGTHS 45.4 TO 81.4 FT.		
	LOADED BOOM ANGLE Δ°	RATED LOAD POUNDS	
		360°	REAR
20	72	11000	11000
25	69	11000	11000
30	65	9600	9700
35	61	7800	7900
40	57	6300	7000
45	52	5000	6600
50	47	4100	5600
55	42	3300	4800
60	37	2700	4100
65	30	2200	3500
70	22	1800	3000

LATTICE EXTENSION MANUAL EXTENDED			
LOAD RADIUS (FEET) FOR 103.38 FOOT BOOM ONLY	FOR ALL BOOM LENGTHS 49.4 TO 103.4 FT.		
	LOADED BOOM ANGLE Δ°	RATED LOAD POUNDS	
		360°	REAR
25	73	6800	6800
30	70	6200	6200
35	67	5500	5500
40	64	5000	5000
45	61	4600	4600
50	58	4100	4200
55	55	3600	3900
60	51	3000	3600
65	47	2500	3300
70	43	2100	3100
75	40	1800	2900
80	34	1400	2600
85	29	1200	2300

FOR BOOM ANGLES NOT SHOWN, USE RATING OF NEXT LOWER BOOM ANGLE

2232U460

WARNING: Do not exceed rated load radius for a rated load.

WARNING: Main boom ratings must be reduced by weight of fixed boom attachments. See table.

“on tires”
rated crane loads in pounds — main boom — without outriggers
— 1500 lbs. counterweight

RATED LOADS FOR 14:00 x 24 — 18 PLY TIRES					RATED LOADS FOR 17.50 x 25 — 20 PLY TIRES			
STATIONARY		CREEP	2½ MPH	LOAD RADIUS (FEET)	STATIONARY		CREEP	2½ MPH
± 6° ARC OVER REAR	360° ARC	BOOM CENTERED OVER REAR			± 6° ARC OVER REAR	360° ARC	BOOM CENTERED OVER REAR	
30800	15900	22900	17100	10 ⊙	33800	16200	33800	24200
26800	12200	19900	14900	12 ⊙	29400	12200	29400	21000
22400	8200	16700	12500	15 ⊙	24600	8400	24600	17600
15300	4700	13100	9800	20 ⊙	13800	4510	13800	13800
9200	2400	9200	8100	25	8500	2300	8500	8500
6300	1200	6300	6300	30	5400	1000	5400	5400
4400	—	4400	4400	35	4200	—	4200	4200
3800	—	3800	3800	40	3600	—	3600	3600
2700	—	2700	2700	45	2700	—	2700	2700
2000	—	2000	2000	50	1900	—	1900	1900
1300	—	1300	1300	55	1300	—	1300	1300

32Q1184

32Q1185

⊙ RATINGS LIMITED TO FULLY RETRACTED BOOM.

WARNING: DO NOT EXCEED RATED LOAD AT RADIUS SHOWN OR A TIPPING CONDITION WILL OCCUR.



NOTE: All designs, specifications and components of the equipment described above are subject to change at the manufacturer's sole discretion at any time without advance notice. Data published herein is informational in nature and shall not be construed to warrant suitability of the machine for any particular purpose as performance may vary with the conditions encountered. The only warranty applicable is our standard written warranty for this machine. Manufactured and sold in conformance with U. S. Department of Commerce Commercial Standard CS-90-58.

Address inquiries to

