

Product advantages

Mobile Crane LTM 1250/1

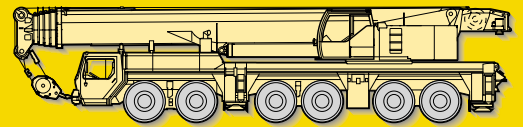

Max. lifting capacity: 250 t at 3 m radius
Max. height under hook: 108 m with swing-away jib
Max. radius: 92 m with swing-away jib



Performance profile of the LTM 1250/1 at a glance:

- 6-axle carrier, 6-section, 72 m long telescopic boom
- 72 t total weight (12 t axle load)
- Multivariable boom system: 72 m telescopic boom, biparted swing-away jib, 12.2 m to 36 m, fixed or luffing lattice jib of up to 42 m or 70 m length
- Outstanding load capacities, flexible counterweight distribution 97.5 t, 85 t, 72.5 t, 60 t, 47.5 t, 35 t, 22.5 t, 10 t or 0 t
- Ultramodern boom technology, optimized, oviform boom profile, patented internal interlocking system of the telescopes, rapid cycle telescoping system "Telematik"
- Latest data bus technique with 4 Liebherr system busses, electronic controlled drive management by CAN bus
- Powerful, energy-saving and emission-optimized Liebherr Diesel engines; carrier engine of 440 kW output (Euro 3), crane engine of 180 kW output (acc. to step 2 EG 97/68)
- Modern crane cab with ergonomical layout, cab tiltable by 20°
- The LTM 1250/1 is manufactured by Liebherr within the scope of a quality assurance system acc. to DIN EN ISO 9001

LIEBHERR

The better crane.

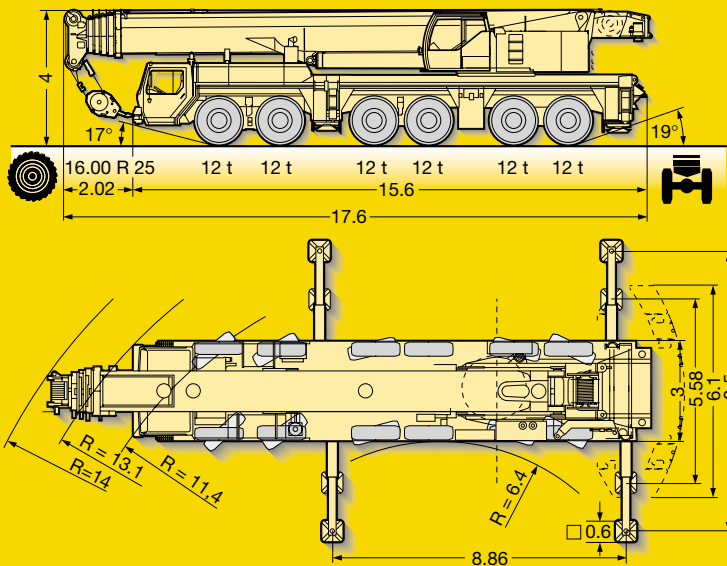

Compact, manoeuvrable and safe.

- Overall length 17.6 m, carrier 15.6 m long
- Large overhang angles, front up to 17°, rear up to 19°
- Smallest turning radius by 5-axle steering (13.1 m over carrier)
- Axle load equalization (12 t) due to hydropneumatic suspension "Niveaumatik"
- In addition to service and parking brake, the following sustained-action brakes are part of the standard equipment for safe travel: retarder in the automatic transmission and engine brake as exhaust brake with Liebherr auxiliary brake system by valve control (ZBS)

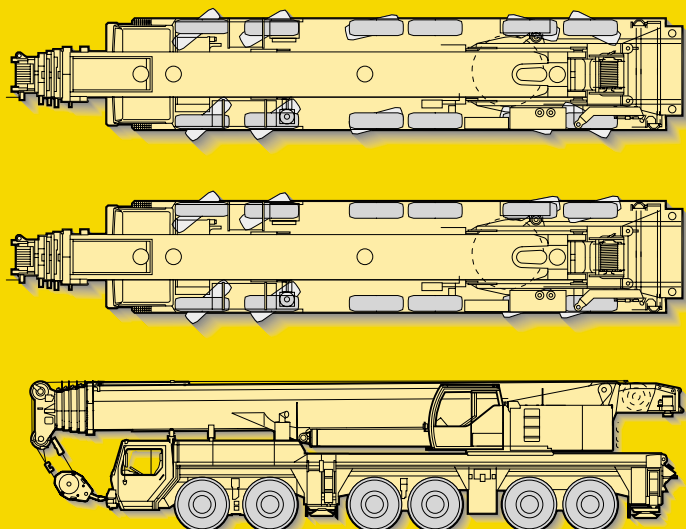

Variable drive and steering concept.

- Standard 5-axle steering, 5th and 6th axle are also steerable independent from axles 1 - 3. During crab steering/diagonal displacement, axles 3 and 4 are raised hydraulically
- Drive 12 x 6, axles 1, 5 and 6 are driven
- Drive 12 x 8, axles 1, 3, 5 and 6 are driven, 3rd axle activatable for off-road travel
- Electronically controlled Allison automatic transmission Typ CLBT 755 with 5 forward speeds/1 reverse gear, robust and reliable automatic gear which decisively improves the driving comfort
- Transfer gear with off-road ratio and transfer differential
- Driving axles with differential locks for transverse locking in off-road ratio

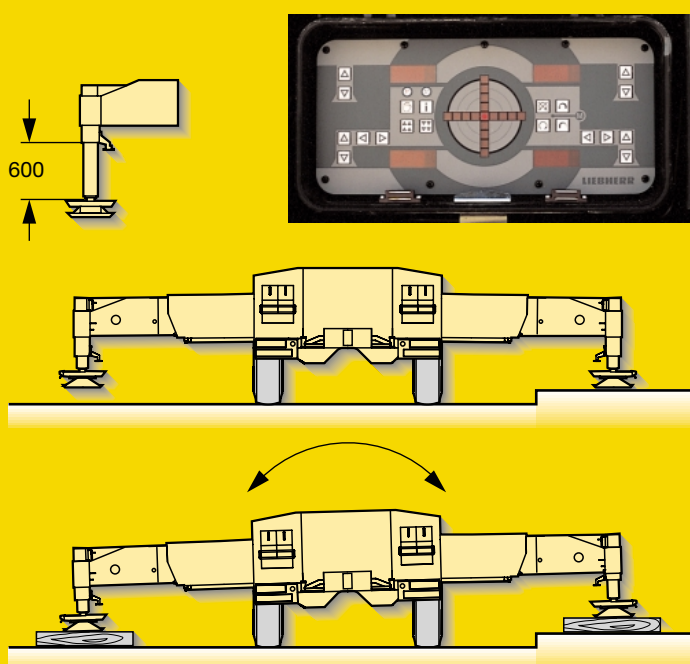

Setting crane on outriggers - quick, convenient and safe.

- Supporting basis 8.84 m x 8,5 m or 8.84 m x 5.58 m
- Fixed lightweight supporting pads (plastic) with lateral compensation
- Supporting rams with 600 mm travel
- Level control of supporting system, all-automatic leveling of the crane during the supporting procedure by "push-button control"
- 2 x 9° lateral inclination even with locked suspension
- Inclinometer (electronic inclination indicator) with two displays on the carrier and one display on the LICCON monitor in the crane cab
- 2 supporting force indicators on the control panels on the carrier and on the LICCON monitor
- Operation of the outrigger system in accordance with the rules for the prevention of accidents

The LTM 1250/1 - more benefit through advanced technology.

Ultramodern boom technology.

- 72 m long, 6-section telescopic boom
- Features of the new boom technology:
 - optimized, oviform boom profile – patented internal interlocking system of the telescopes
 - automatic telescopic system “Telematic”
- Telescopic boom with electronically controlled telescoping system
- Boom bearings of low maintenance polyamide slide blocks
- Outstanding lifting capacities, e.g.
 - 84 t at 10 m radius
 - 38 t at 20 m radius
 - 15.4 t at 40 m radius
 - 8.4 t at 60 m radius
 - 2.1 t at 80 m radius
 - 1.1 t at 92 m radius

Powerful carrier drive.

- 8-cylinder Liebherr turbo-charged Diesel engine type D 9408 TI-E with charge cooling, 440 kW/598 h.p., emission-optimized (Euro 3), energy-saving, robust and reliable, electronic engine management
- Allison automatic transmission with torque converter and hydrodynamic brake, electronic transmission management, 5 forward speeds and 1 reverse gear, proved and well tested serial transmission
- 2-step, robust transfer case with transfer differential
- Robust crane axles, welded design
- Max. driving speed 76 km/h, max. gradability 43 %

Crane cab of modern design.

- Steel-fabricated and corrosion-resistant crane cab, powder-coated, with internal sound and heat absorbing panelling, modern interior design, tinted panes all-round, front knockout window with large windscreen wiper and washer, skylight of bullet-proof glass with large windscreen wiper and washer, roller blinds on front window and skylight, space saving sliding door
- Additional heater Thermo 90 S (Webasto) with engine preheating
- Pneumatic operated footboard for safe access to the carrier
- Crane cab tiltable by 20° to the rear

Crane drive with field-proven components.

- Crane engine: 4-cylinder Liebherr turbo-charged Diesel engine type D 924 TI-E of 180 KW/245 h.p. (acc. to directive 97/68 EG), robust and reliable, located opposite to the crane cab, thus reduced noise pollution; electronic engine management, optimized fuel consumption, exhaust gas system of stainless steel, very efficient noise abatement of the dieselhydraulic crane drive
- Slewing rim, slewing gear and the winches are self-manufactured components specially matched for the application on mobile cranes
- The centralized lubricating system for slewing rim, boom bearing application, luffing rams and winch bearings is a standard feature

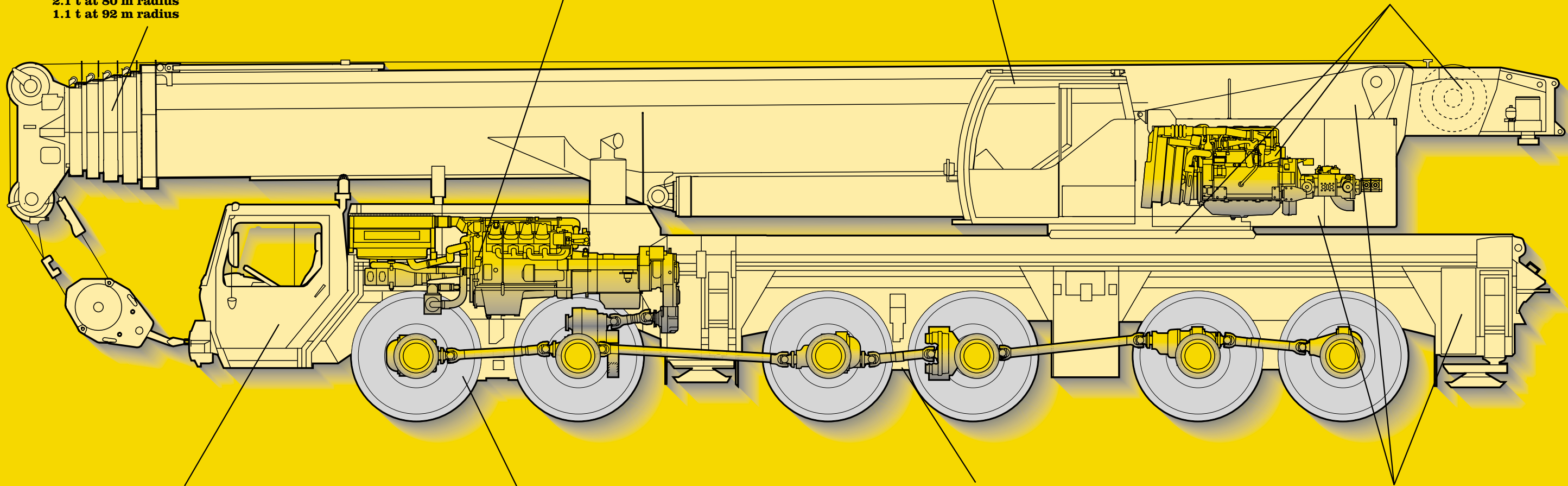

Modern and comfortable driver's cab.

- Steel-fabricated, corrosion resistant cab, cataphoretic dip-primed, front section on rubber shock absorbers, rear section on hydraulic dampers, internal sound and heat absorbing panelling, modern interior design of outstanding functionality
- Safety glass all-round, green-tinted heat-isolating front and side window panes, electric window lifters
- Standardised digital operating and control elements arranged in an operator-friendly halfround shape
- Additional heater Thermo 90 S (Webasto) with engine preheating

Outstanding carrier technology for road and off-road operation.

- Weight-optimized and low maintenance axles of high-tensile steel, perfect track-keeping and lateral stability due to special control linkage arrangement
- The low maintenance steering nuckles are steel and rubber mounted, thus bearing failures are practically ruled out
- The perfected and robust axles are manufactured in large series and are part of the trouble-free components of a mobile crane
- The cardan shafts are maintenance-free. The 70° diagonal toothing and 4 fixing bolts enable easy and fast fitting of the cardan shafts

Crane- and road-preserving Niveaumatik suspension.

- Maintenance-free suspension rams, free from lateral forces and protected against damage by synthetic tubes
- Level adjustment (suspension set to “travel mode”) can be performed automatically from any position by push-button control
- Stable cornering ability of the crane due to cross mounting of the hydropneumatic suspension
- Axle locking system (blocking of the suspension for travelling with equipment) integrated into the suspension rams and controllable from the driver's cab

Weight-optimized steel structure.

- Carrier, superstructure and telescopic boom in light-gauge design, calculated by the F.E.M. method, thus weight-optimized and particularly torsionally rigid
- Tensile property of the material with high safety factors through the application of STE 960 (960 N/mm²) for all supporting members. Telescopic boom bottom shell of ultra-high tensile steel S 1100 QL (1100 N/mm²)
- Weldment joints of outstanding quality are performed by computer-aided welding machines
- The weld quality is documented by ultrasonic test

Comfortable driver's cab of outstanding functionality.

- Modern and comfortable driver's cab of outstanding functionality and convincing design
- Ergonomically arranged operating and display units for safe and convenient handling at permanent operation
- Digital display and keyboard units interconnected with the function blocks by data bus technique
- Air-cushioned driver's and co-driver's seat with head rests, driver's seat with lumbar support
- Auxiliary heater with engine preheating
- Safety belts for driver and co-driver
- Height and inclination adjustable steering wheel
- Heated and electrically adjustable rear mirrors
- Side panes with electric window lifters
- 3 automatic windscreen wipers with washing device and intermittent control
- Delayed disconnection or interior lighting
- Various racks and boxes
- Radio preparation



Comfortable crane cab of outstanding functionality.

- Spring-mounted and hydraulically cushioned crane operator's seat with pneumatic lumbar support and headrest
- Operator-friendly armrest-integrated controls, vertically and horizontally adjustable master switch consoles and ergonomically adjustable operating consoles
- Ergonomic control levers with integrated winch rotation and slewing indicator
- Modern instrument supporting base with integrated LICCON monitor, display of all essential operating data on the LICCON screen
- Green-tinted heat-isolating front and side window panes
- Wiper/washer device for front window and skylight
- Auxiliary heater with engine preheating
- Various racks and boxes
- Radio preparation
- 1 working projector 70 Watt on the cabin front



- The electric and electronic components are interconnected by the latest data bus transmission technique
- Instead of the traditional electric wiring, the data transmission to the individual function blocks is performed digitally just by a few data cables, thus improved reliability due to essentially less contacts
- Self-manufactured Liebherr bus systems (LSB), specially adapted to the requirements of a mobile crane
- Diesel engine and automatic transmission are controlled by a CAN data bus. The all electronic drive management reduces fuel consumption and improves the exhaust gas emission
- The electric systems of the carrier and crane as well as of all cockpit functions, the outrigger system and sensor system of the boom are interconnected by 4 Liebherr system busses
- The control of the function blocks is realized by I/A modules the programming of which is performed by means of the Liebherr system busses. The control intelligence is integrated into the LICCON central unit
- Comprehensive diagnostic facilities, quick error localization, operating error display
- Test programs for functional test of keyboard and display unit as well as for the test of the control units for engine and transmission management, additional Liebherr brake system, hydraulic ventilator, hydraulic suspension and outrigger control panels
- The new data bus technique distinctively increases functionality and efficiency of the mobile crane

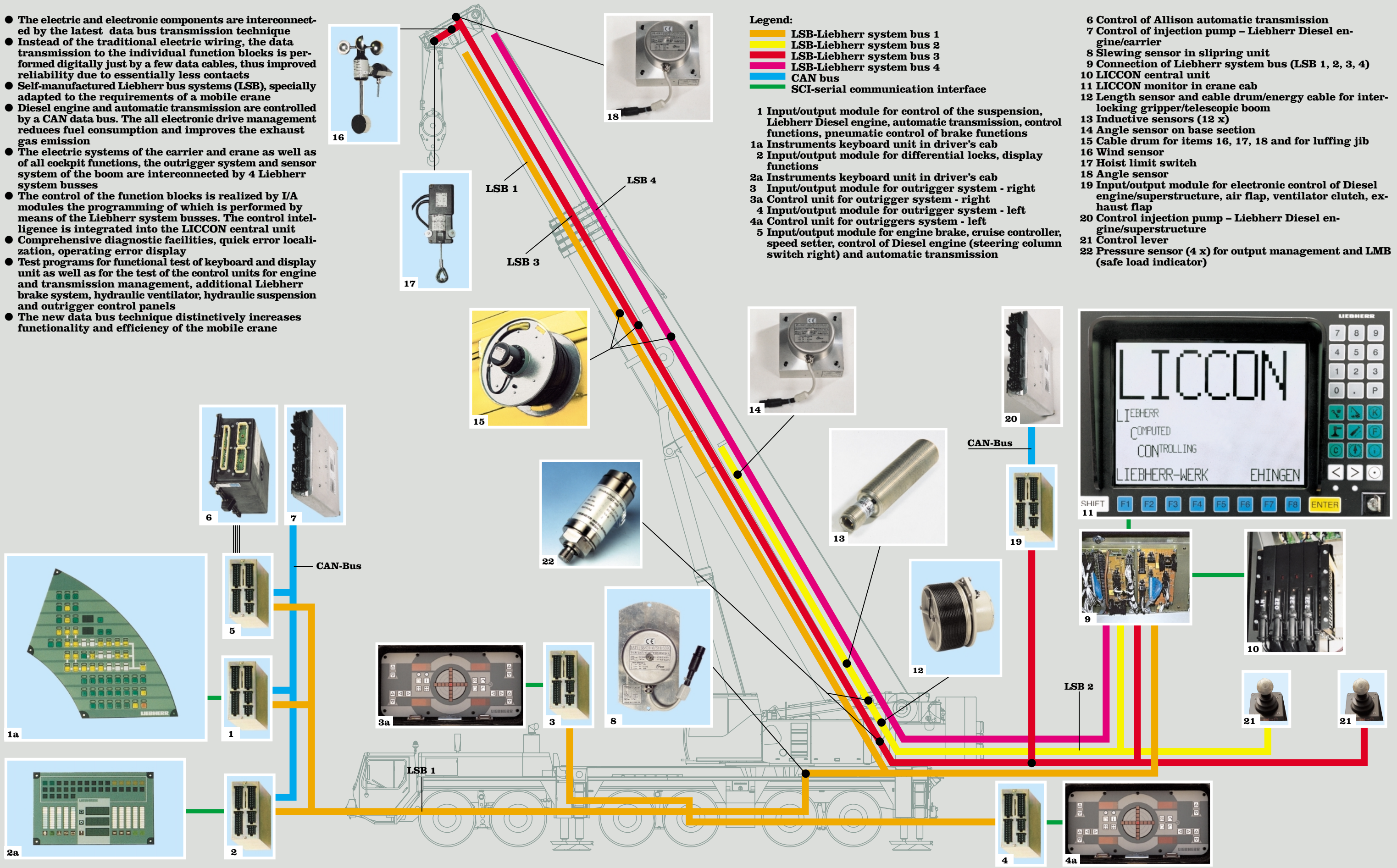

Legend:

- █ LSB-Liebherr system bus 1
- █ LSB-Liebherr system bus 2
- █ LSB-Liebherr system bus 3
- █ LSB-Liebherr system bus 4
- █ CAN bus
- █ SCI-serial communication interface

- 1 Input/output module for control of the suspension, Liebherr Diesel engine, automatic transmission, control functions, pneumatic control of brake functions
- 1a Instruments keyboard unit in driver's cab
- 2 Input/output module for differential locks, display functions
- 2a Instruments keyboard unit in driver's cab
- 3 Input/output module for outrigger system - right
- 3a Control unit for outrigger system - right
- 4 Input/output module for outrigger system - left
- 4a Control unit for outriggers system - left
- 5 Input/output module for engine brake, cruise controller, speed setter, control of Diesel engine (steering column switch right) and automatic transmission

- 6 Control of Allison automatic transmission
- 7 Control of injection pump - Liebherr Diesel engine/carrier
- 8 Slewing sensor in slipping unit
- 9 Connection of Liebherr system bus (LSB 1, 2, 3, 4)
- 10 LICCON central unit
- 11 LICCON monitor in crane cab
- 12 Length sensor and cable drum/energy cable for interlocking gripper/telescopic boom
- 13 Inductive sensors (12 x)
- 14 Angle sensor on base section
- 15 Cable drum for items 16, 17, 18 and for luffing jib
- 16 Wind sensor
- 17 Hoist limit switch
- 18 Angle sensor
- 19 Input/output module for electronic control of Diesel engine/superstructure, air flap, ventilator clutch, exhaust flap
- 20 Control injection pump - Liebherr Diesel engine/superstructure
- 21 Control lever
- 22 Pressure sensor (4 x) for output management and LMB (safe load indicator)

Data bus technique improves functionality and efficiency.

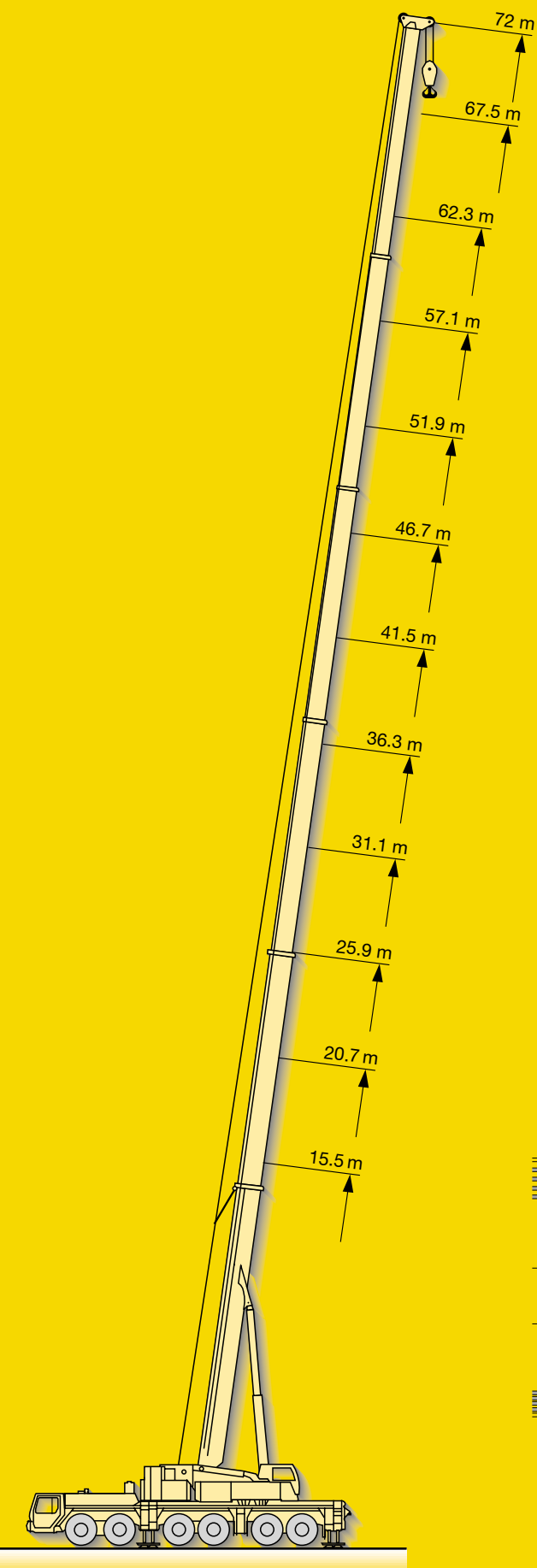

Load handling - precise and safe.

- 6-section, 72 m long telescopic boom for 72 m height under hook and 66 m radius
- Optimized, oviform boom profile with continuous curvature of the bottom shell and offset joint, high deformation stability for maximum loads
- Broad boom profile for strengthening of the lateral bending axis and stabilization of long additional booms
- Patented internal locking system of the telescopes - reliable and maintenance-free
- High functionality of the boom system due to the automated telescoping system "Telematik"
- Optimal utilization of the telescopic boom due to a multitude of telescoping variants

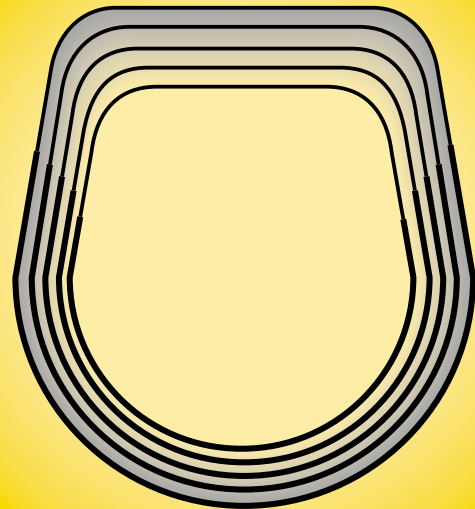

oviform boom profile

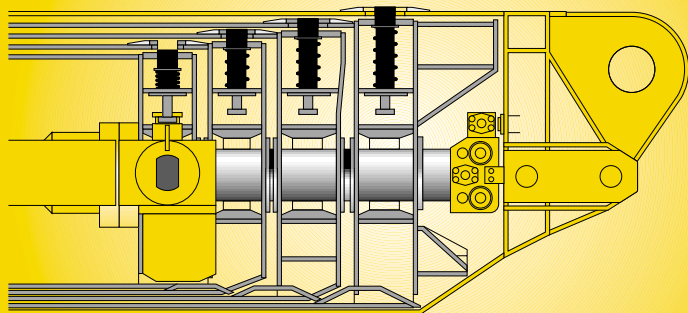

Boom systems for multi-purpose applications.

Multi-variable boom configuration system.

- Telescopic boom T, 15.5 m – 72 m
- Swing-away jib K, 12.2 m long, biparted swing-away jib K, 12.2 m – 22 m long, extendable up to 36 m, mountable at 0°, 20° or 40°
- Special swing-away jib, 3.4 m long
- Fixed lattice jib TF, 14 m – 42 m, mountable at 0°, 20° or 40° to the 51.9 m – 72 m long telescopic boom
- Luffing lattice jib TN, 17.5 m – 70 m, mountable on the 15.4 m – 67.5 m long telescopic boom with continuous inclination between 82° and 68°
- Intermediate sections TF and TN equipment identical and can be slid into one another for transportation
- Jib A-frames with T-adapter and N-base section form a complete transport unit and can be mounted with just 4 pins
- Easy-to-rig stay rods which remain on the intermediate sections during transportation
- Auxiliary winch on the superstructure for easy reeving of the hoist and luffing ropes
- Rigging of the lattice jib is practicable in suspended condition on restricted sites
- Winch 2 for luffing operation of the jib
- Continuous load capacity interpolation during luffing of the boom combinations TN between 82° and 68° inclination of the telescopic boom

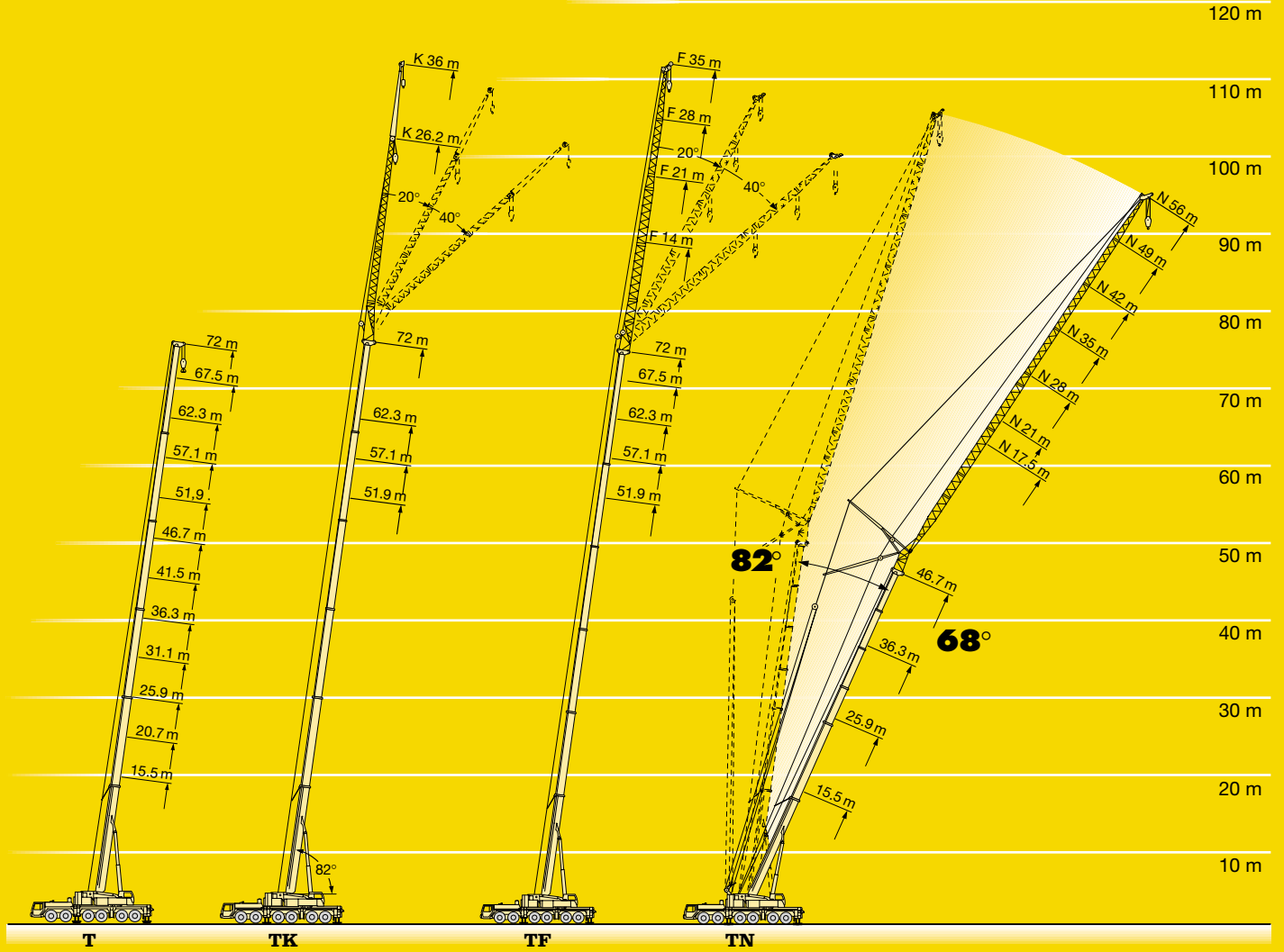

LICCON computer system for control and monitoring functions.

- Standard application programs: Safe load indicator (LMB), configuration program with configuration image, telescoping program with telescoping image, supporting force display, control parameter program, test system; and as an option, the work area limitation and the LICCON work planner
- Setting of the crane configuration by convenient interactive functions
- Safe and reliable acknowledgement of the crane configuration set
- Representation of all essential data by graphic symbols on the operating image
- With integrated wind speed control
- Reliable cut-off device in the event of exceeding the admissible load moments
- Safe working load values for any intermediate boom length
- Winch indications for ultra-precise lifting/lowering of the load

		CODE>0018<B131 1500.2(5)						
		m> <t						
		57,1	62,3	62,3	67,5	72,0	20,7	25,9
10,0	24,0						46,0	36,5
11,0	23,2	20,7	20,0				46,0	36,5
12,0	22,5	20,7	20,0	17,0			46,0	36,5
14,0	21,0	20,6	19,5	16,9	14,0		46,0	36,5
16,0	19,6	19,9	18,6	16,8	14,0		46,0	36,5
18,0	18,3	18,9	17,7	16,2	13,9		23,6	36,5
20,0	17,0	17,7	16,6	15,6	13,5			36,5
22,0	15,7	16,5	15,5	14,8	13,1			31,0
24,0	14,5	15,4	14,6	14,0	12,4			
* n *	* 3 *	* 2 *	* 2 *	* 2 *	* 2 *	* 5 *	* 4 *	
48(95)	<<							>>
1	0 +	92 +	46 +	92 +	100 +	0 +	46 -	
2	92 +	92 +	92 +	92 +	100 +	46 -	46 -	
3	92 +	92 +	92 +	92 +	100 +	0 +	0 +	
4	92 +	92 +	92 +	92 +	100 +	0 +	0 +	
5	92 +	46 +	92 +	92 +	100 +	0 +	0 +	

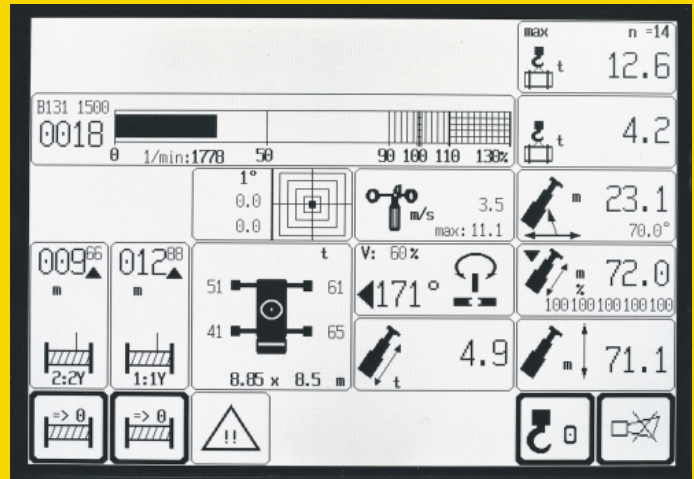
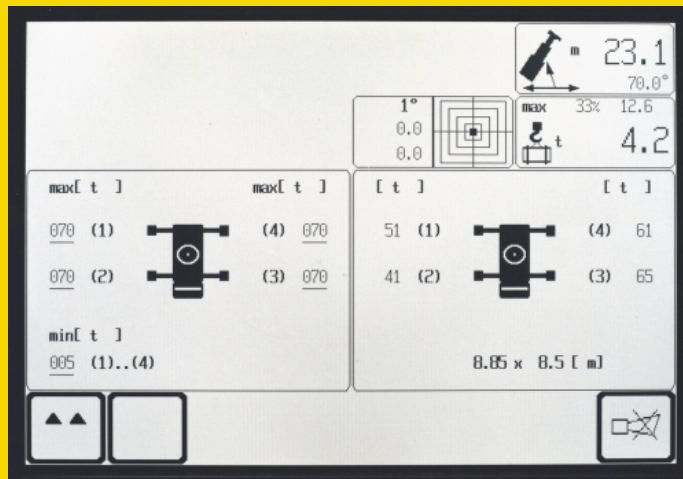

LICCON-assisted telescoping system.

- Telescoping by single-stage hydraulic ram with hydraulic driving tenons (patented internal interlocking system)
- Telescoping procedure controllable by convenient operator's guide on the monitor, precise approach of the interlocking positions
- Telescopic loads are displayed on the LICCON operating image
- Rapid-cycle telescoping system with "automatic mode", i.e. all automatic telescoping of the boom to the desired length
- Particularly compact and light-weight telescopic system, thus increased lifting capacities specially with long booms at large radii
- Automatic cushioning in end positions during telescoping and retracting for the preservation of the structural members

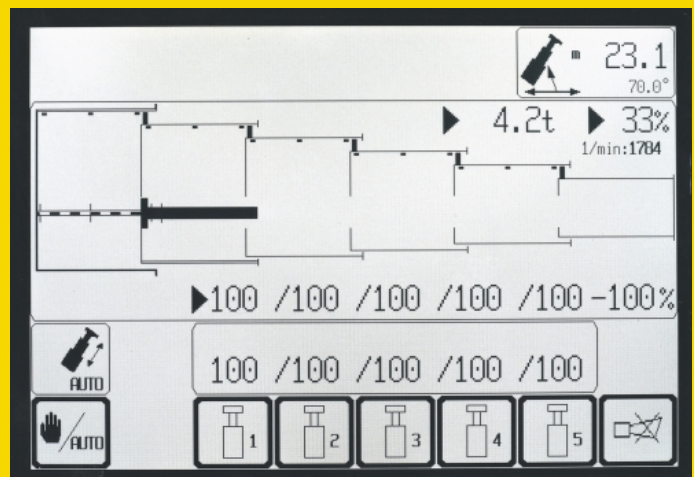

The LICCON computer system offers top technology.

The LICCON test system.

- The test system assists the servicing personnel in quickly localizing errors of the sensor system without needing any further measuring instruments
- Convenient interactive functions permit the observation of all in- and outputs of the general system by different displays on the monitor even during crane operation. It equally visualizes the allocation of the individual sensors to the system as well as their function and the terminals concerned in the control cabinet
- The table of contents enables the display of the contents and the state of development of the program modules as well as the load charts on the monitor
- The service starts on the monitor, error detection becomes a matter of seconds

SYSTEM-FUNKTION: AUSGANG		GRUPPE 0	ZE 0
A 0..n	DOCUMENTATION	D	I-SOLL I-IST
A 0.0 :	LMB Abschaltung	(D)	0 - 0 mA
A 0.1 :	Druckstufe -Y11a	(D)	0 - 0 mA
A 0.2 :	Druckstufe -Y11b	(D)	0 - 0 mA
A 0.3 :	Druckstufe -Y12	(D)	0 - 0 mA
A 0.4 :	Drehen, Freilauf	(D)	0 - 0 mA
A 0.5 :	Drehen, Bremse	(D)	0 - 20 mA
A 0.6 :	Drehen, rechts	(A)	0 - 0 mA
A 0.7 :	Drehen, links	(A)	0 - 0 mA

BINER DEZ/HEX STOP ZURUECK <=>

The LICCON work area limitation system.

- It relieves the crane operator, especially in situations where the handling of loads requires his full attention, by controlling the work area limits. Work areas can be restricted by buildings, bridges, roofs, high-tension lines, pipe lines or adjacent cranes. The automatic work area limitation system (optional) can easily be programmed. Four different limitation functions are practicable:
- Height limitation of the pulley head
- Radius limitation
- Slewing angle limitation
- Limitation of edges

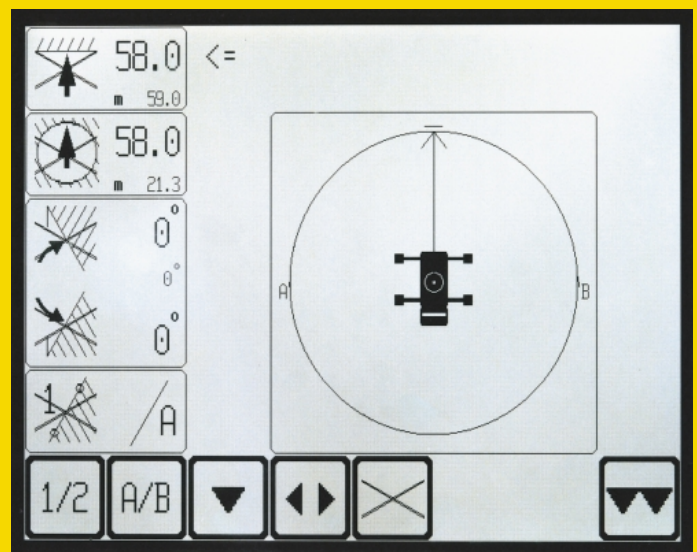

The LICCON work planner.

- The LICCON work planner consists of a software program on diskettes for planning, simulation and documentation of crane applications on the monitor (option)
- The 2-D planner allows to draw buildings, to write texts and to represent a crane model true to scale including its motions within a fictional construction site
- The work planner enables the preparation of more transparent offers, facilitates the briefing of the crane operators and it can be run on a laptop at the construction site

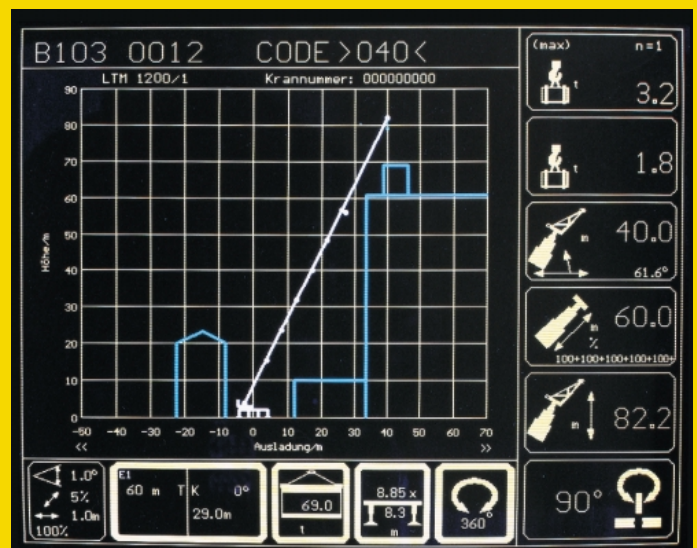

Mounting of counterweight - just a matter of minutes.

- Counterweight variants 0 t, 10 t, 22.5 t, 35 t, 47.5 t, 60 t, 72.5 t, 85 t und 97.5 t
- Ballasting controlled from the crane cab
- Quick ballasting due to the keyhole system

- Ballast rams fix-mounted to the superstructure
- Compact counterweight dimensions, e.g. 47.5 t counterweight of 3 m width only

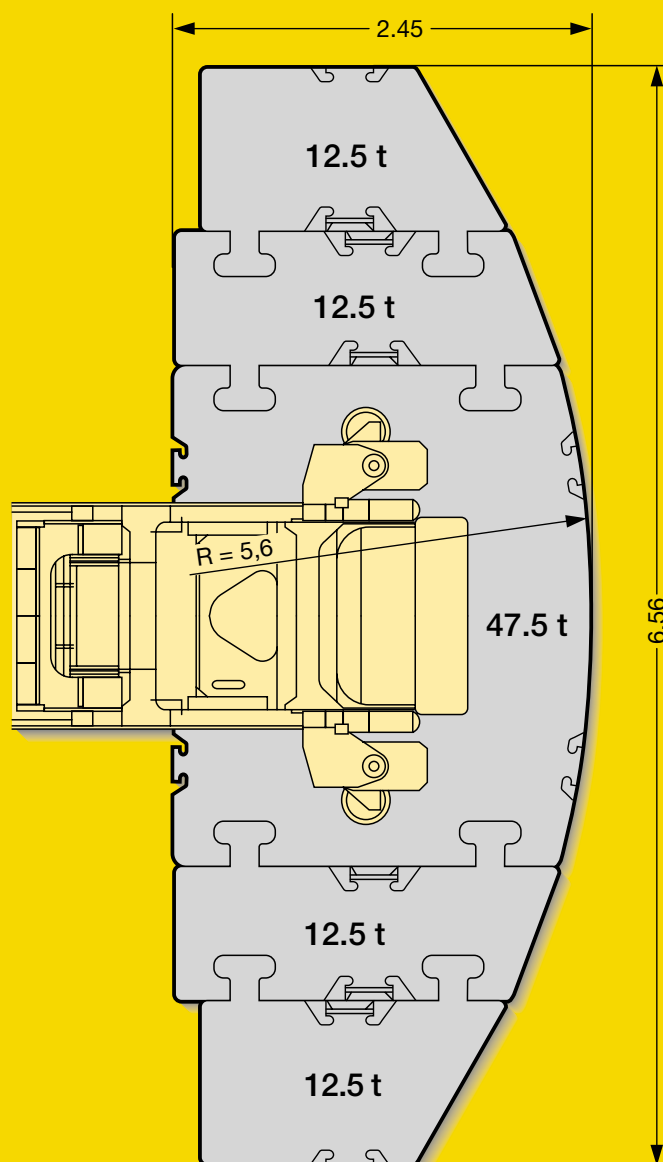
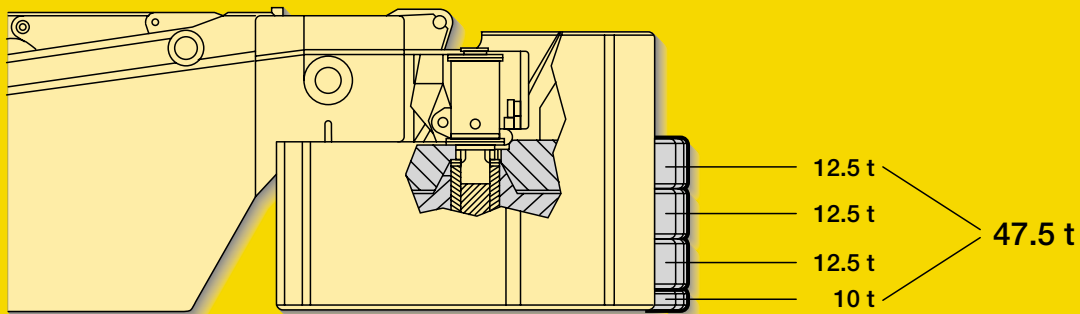

Electric/electronic crane control with integrated safe load indicator.

- Control of winches, slewing gear as well as luffing and telescoping motions by the LICCON system (PLC control)
- Four working motions can be performed independent from one another
- Speeds of hoisting/lowering, slewing and luffing are preselectable in 5 steps
- Luffing speed controlled automatically dependent on the boom length
- Extremely short response times when initiating crane motions
- Hoist gear and slewing gear are operating in a "closed oil circuit". This ensures high-precision lifting, lowering and slewing of loads. Moreover, the potential energy generated during lowering is not transformed into heat but can be reemployed for a 2nd motion which results in the particular advantage of fuel saving and reduced thermal exposure of the oil than in an open circuit
- Functional test of all essential components by the LICCON test system

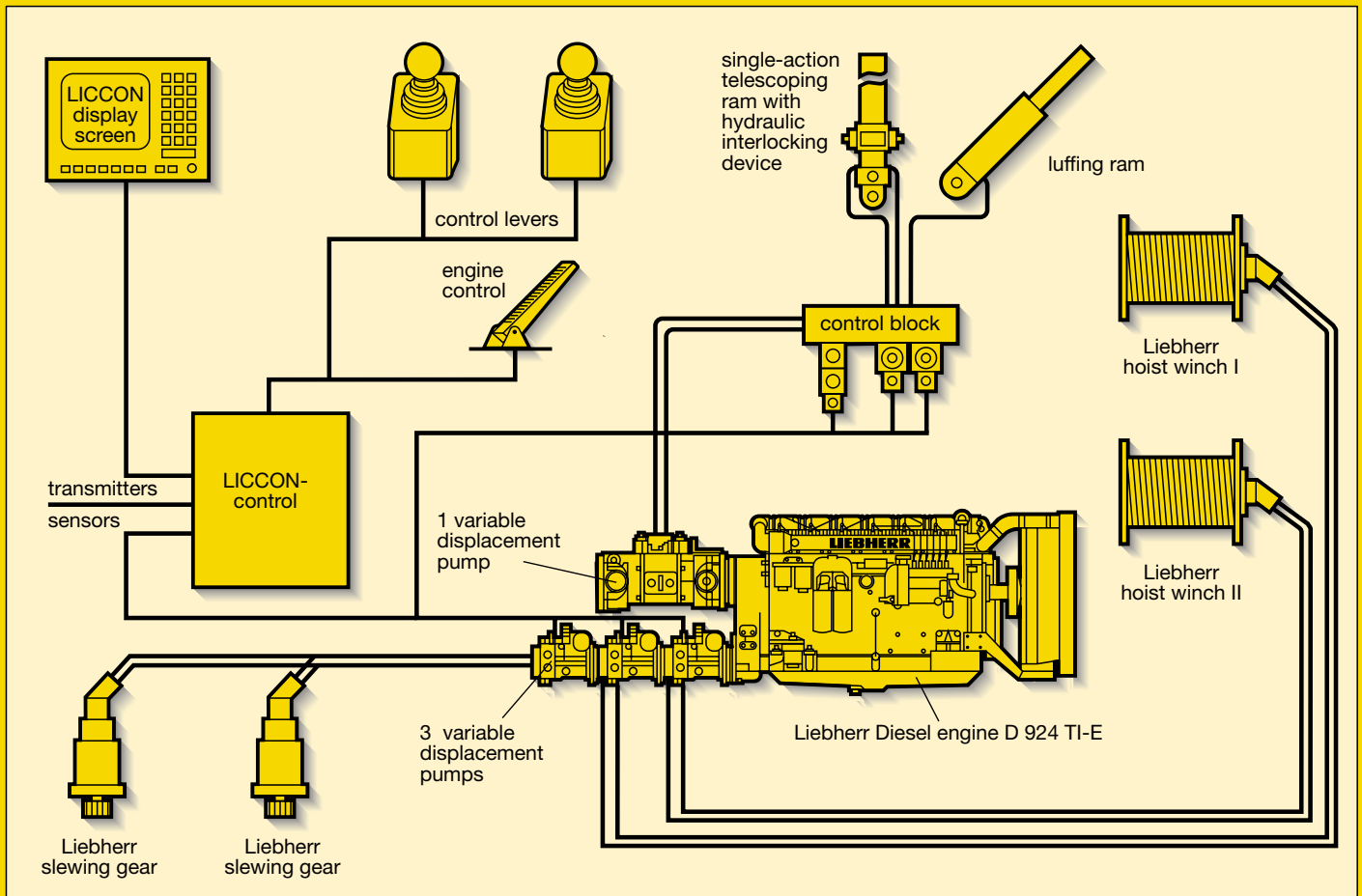

Optional features extend the application spectrum and increase comfort and safety.

On the carrier

- Eddy-current-brake
- Stow-away box for sling gear and stand timber
- Air-conditioning system
- Trailer coupling D12/D19
- Radio preparation
- Seat heating for driver's and co-driver's seat
- Fog lamps
- Cassette radio set

On crane superstructure/telescopic boom

- 2nd hoist gear
- Air-conditioning system
- Seat heating
- Work area limitation
- Work projector 1 x 70 W on cabin roof
- Work projector 2 x 150 W – electrically adjustable – on boom base section
- whip line
- Erection jib
- GSM module for remote diagnostics
- Radio preparation
- Cassette radio set
- Crane data logger

Further optional features by request.

Subject to modification.

TP 339. 12.01

Please contact
LIEBHERR-WERK EHINGEN GMBH, Postfach 1361, D-89582 Ebingen
☎ (0 73 91) 5 02-0, Fax (0 73 91) 5 02-33 99
www.lwe.liebherr.de, E-Mail: info@lwe.liebherr.com