

US60-1R

Single Car Personnel/Material Hoist

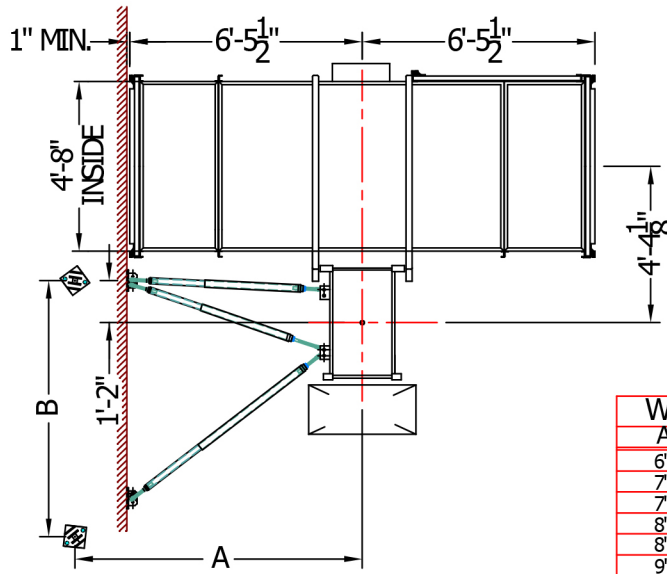
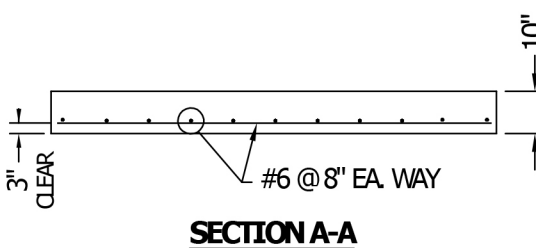
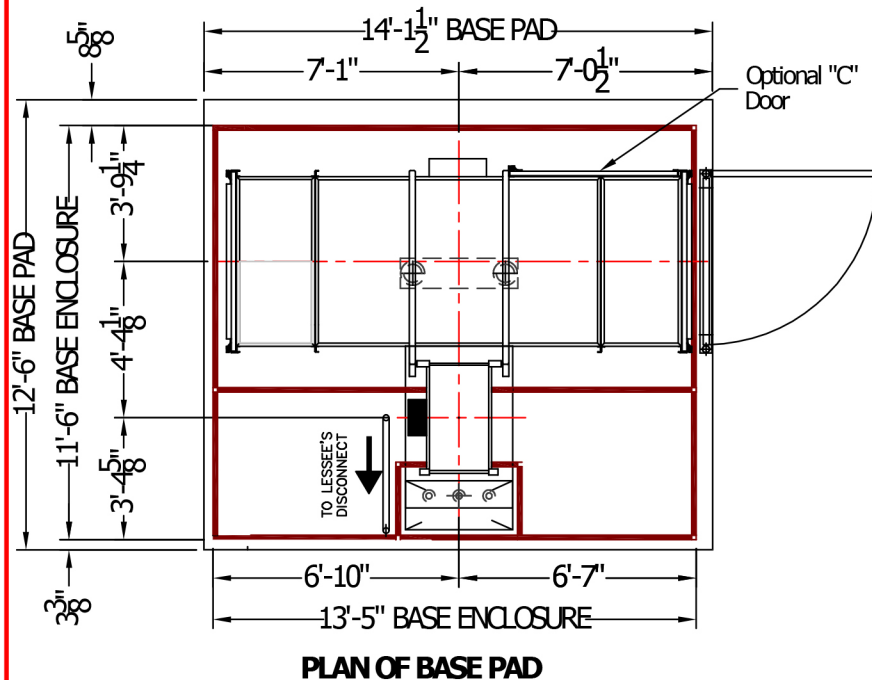

WALL TIE	
A	B
6'-7"	5'-11"
7'-2"	6'-3"
7'-8"	6'-6"
8'-2"	6'-10"
8'-8"	7'-1"
9'-2"	7'-5"
9'-8"	7'-8"
10'-2"	8'-0"
10'-8"	8'-3"

Maximum passengers	30
Elevator drive	Rack and pinion
Capacity	6,000 lbs (2722 kg)
Car Weight	6,600 lbs (2944 kg)
Total base weight	15,656 lbs. (7,116 kg.)
Base disconnect	Circuit Breaker in NEMA 4 Enclosure
Electrical outlet	120 vac in Car
Weight of tower	300 lbs (136 kg)
Wall ties	Adjustable strut
Landing gates	Swinging gates
Maximum car speed	150 ft/min (45.72 m/min)
Interior dimensions	12'-4" L x 4'-8" W x 7'-2" H (3.8 m L x 1.4 m W x 2.2 m H)
Maximum tower height	900' (274.32m)
Dimensions of tower	38" W x 28" L x 59.4" (.97 m x .71 m x 1.52 m)
Tie-in intervals (maximum)	30' (9.14m)
Electrical Power	35 HP (26 kW)
Power Required	33 KVA, 480 VAC, 60 Hz, 3 Ø
Motor Control	Variable Frequency Drive (optional)
Full load current	39.5 Amps
Traveling Cable	Multi-Conductor Type W-Tower Height Plus 30Ft (9.14m)
Brake	Spring set, Electrical Release Multiple Disc Brake
Safety overspeed governor	Centrifugally Actuated Multiple Friction Disc Brake
Emergency lowering	Manual Brake Release
Stopping distance accuracy	±.6" (± 15.24 mm)
Brake torque	175 ft/lbs. (102Nm)
Weight of counterweight	5600 lbs. (2545 kg.)
Counterweight wire ropes	(2) 5/8" (15.88 mm) 6x25 xIP-IWRC
Length of counterweight ropes	2 x Tower Height Plus 30' (9.14 m)

- STANDARD BASE UNIT**
- Fully assembled enclosed car
 - Overspeed governor
 - Two manually operated vertically bi-parting car gates
 - Control and limit switches
 - 20' of tower for 0 lifting height
 - Hot Dipped Galvanized Car & Tower
 - Counterweight & cathead Assembly
 - Variable Frequency Drive (VFD)
 - Base fence enclosure
 - Base disconnect box
 - Buffer stand and springs
 - Power cord guide trailing wheel assembly
 - GFI Receptacle in cr
 - Hand lever control
 - Interior Car Lighting
- OPTIONAL FEATURES**
- Base platform and stairs
 - Building landing gates
 - Landing call station
 - automatic control system
 - Emergency lighting systems
 - Additional tower sections
 - Wall Ties
 - Auxiliary manual hand control provision for opposite hand installation
 - Gin Pole with winch for tower erection
 - Communication or signal system
 - Alarm installation
 - Pit light & switch
 - Pit stop switch
 - Car top light & switch
 - Car top receptacle



SCALE: 1/32=1'-0"

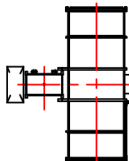

SCALE: 1/16=1'-0"

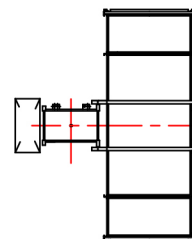

SCALE: 3/32=1'-0"

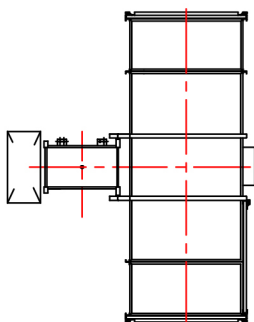

SCALE: 1/8=1'-0"

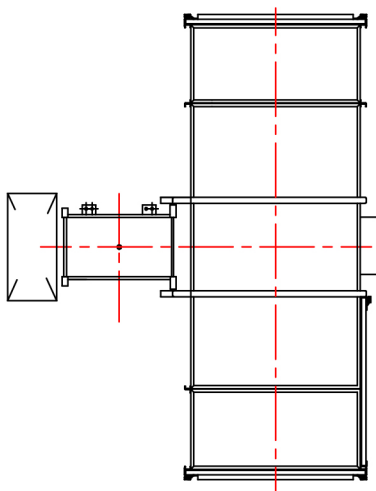

SCALE: 3/16=1'-0"

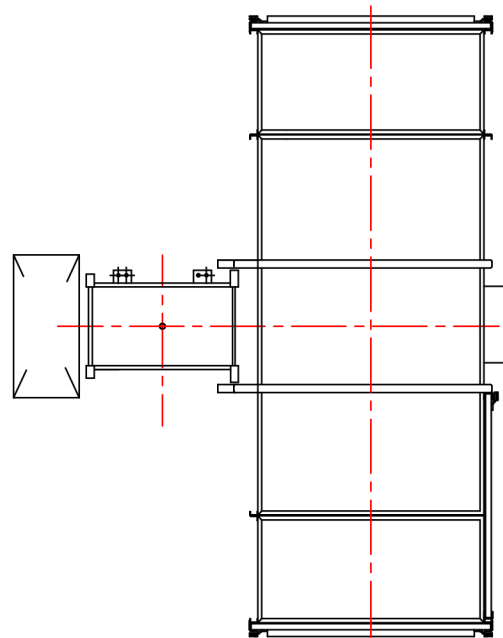

SCALE: 1/4=1'-0"

NOTE:
PLEASE CONTACT METRO ELEVATOR FOR ADDITIONAL SCALES NOT SHOWN HERE.
COPY THIS SHEET TO A TRANSPARENCY FILM, USE IT FOR LOCATING THE HOIST ON AN
EXISTING PAPER PLAN LAYOUT OF THE BUILDING STRUCTURE.

OVERLAY TEMPLATE