



TEREX®

TCX SERIES Hi-Ranger Non-Overcenter Material Handling Aerial Device

AERIAL DEVICES

Terex® Hi-Ranger Aerial Devices are known throughout the industry. They come with a long history featuring quality and innovative design.

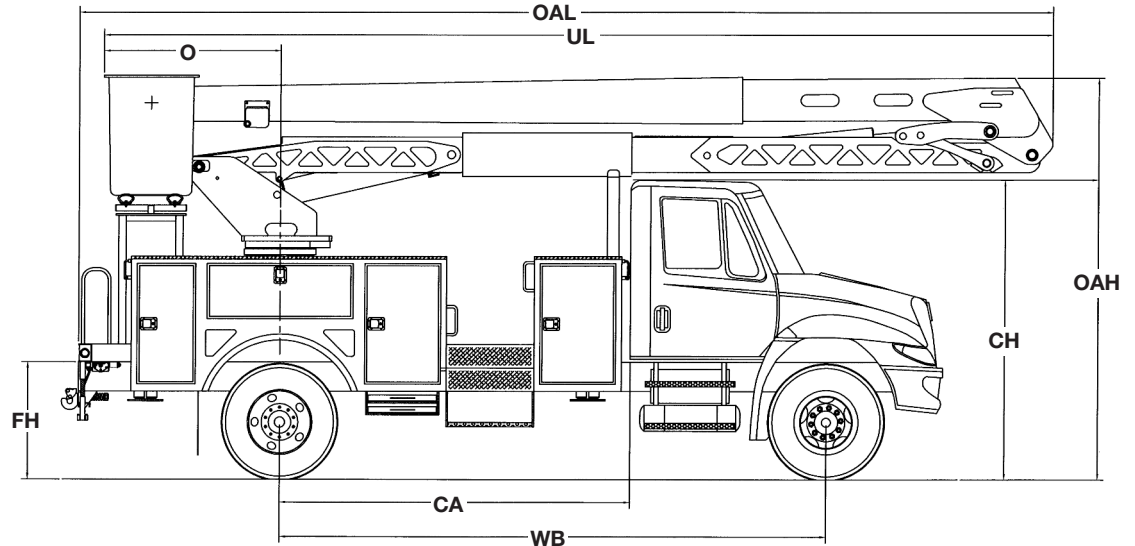

Measurements	TCX52	TCX52	TCX55	TCX55	TCX60	TCX60
	ORA Side Mount	ORA End Mount	ORA Side Mount	ORA End Mount	ORA Side Mount	ORA End Mount
Typical Frame Height (FH)	40 in. (101.6 cm)	40 in. (101.6 cm)	40 in. (101.6 cm)	40 in. (101.6 cm)	40 in. (101.6 cm)	40 in. (101.6 cm)
Typical Cab Height (CH)	108 in. (274.3 cm)	108 in. (274.3 cm)	108 in. (274.3 cm)	108 in. (274.3 cm)	108 in. (274.3 cm)	108 in. (274.3 cm)
Offset (O)	60.5 in. (153.7 cm)	87 in. (221 cm)	60.5 in. (153.7 cm)	87 in. (221 cm)	60.5 in. (153.7 cm)	87 in. (221 cm)
Overall Height (OAH)	12' 1" (3.7 m)	12' 1" (3.7 m)	12' 1" (3.7 m)	12' 1" (3.7 m)	12' 1" (3.7 m)	12' 1" (3.7 m)
Overall Length (OAL)	26' 4" (8.0 m)	28' 2" (8.6 m)	27' 10" (8.5 m)	29' 8" (9.0 m)	30' 4" (9.2 m)	32' 2" (9.8 m)
Unit Length (UL)	25' 7" (7.8 m)	28' 2" (8.6 m)	27' 1" (8.3 m)	29' 8" (9.0 m)	29' 7" (9.0 m)	32' 2" (9.8 m)
Center of Rotation (H)	-	-	-	-	-	-
Cab to Axle (CA)	108 in. (274.3 cm)	108 in. (274.3 cm)	120 in. (304.8 cm)	120 in. (304.8 cm)	120 in. (304.8 cm)	120 in. (304.8 cm)
Wheel Base (WB)	174 in. (442.0 cm)	174 in. (442.0 cm)	188 in. (478 cm)	188 in. (478 cm)	188 in. (478 cm)	188 in. (478 cm)
Front Axle (GAWR)	10,500 lb. (4,763 kg)	10,500 lb. (4,763 kg)	12,000 lb. (5,443 kg)	12,000 lb. (5,443 kg)	12,000 lb. (5,443 kg)	12,000 lb. (5,443 kg)
Rear Axle (GAWR)	19,000 lb. (8,618 kg)	19,000 lb. (8,618 kg)	19,000 lb. (8,618 kg)	19,000 lb. (8,618 kg)	19,000 lb. (8,618 kg)	19,000 lb. (8,618 kg)
Gross Vehicle Weight Rating (GVWR)	29,500 lb. (13,381 kg)	29,500 lb. (13,381 kg)	31,000 lb. (14,061 kg)	31,000 lb. (14,061 kg)	31,000 lb. (14,061 kg)	31,000 lb. (14,061 kg)
Recommended Weight for Stability	26,000 lb. (11,793 kg)	20,000 lb. (9,072 kg)	26,000 lb. (11,793 kg)	20,000 lb. (9,072 kg)	26,000 lb. (11,793 kg)	21,000 lb. (9,525 kg)
Frame Section Modulus	18.0 in ³	18.0 in ³	18.0 in ³	18.0 in ³	18.0 in ³	18.0 in ³
Frame Yield Strength	50,000 psi	50,000 psi	50,000 psi	50,000 psi	50,000 psi	50,000 psi
Frame RBM	900,000 in-lbs	900,000 in-lbs	900,000 in-lbs	900,000 in-lbs	900,000 in-lbs	900,000 in-lbs



TEREX®

500 Oakwood Drive
PO BOX 1150
Watertown, SD 57201-6150
USA

Phone: (605) 882-4000
Facsimile: (605) 882-1842
www.terexutilities.com
E-mail: utilities.info@terex.com

Distributed By:

TCX SERIES

Hi-Ranger Non-Overcenter Material Handling Aerial Device

STANDARD EQUIPMENT

- Side-Mount 24" x 30" x 42" One Person Platform
- Platform Capacity up to 700 lb (318 kg)
- Control-Plus "3-D" Single Stick Control At Platform
- Safety Harness With Attached Lanyard
- Continuous Unrestricted Worm Gear Rotation
- Category "C" Rating Per ANSI A92.2
- Rectangular, Bi-Axial Epoxy Resin, Filament Wound Fiberglass Booms
- Individual Lever Lower Controls
- Power Assist Control System with Automatic Throttle
- Hydraulic Platform Tilt At Upper and Lower Controls
- Hydraulic Platform Leveling System
- 70° of Elevation Above Horizontal
- 188° of Upper Boom Articulation
- 110° of Lower Boom Articulation
- Compensated Boom Design
- Pilot-Operated, Closed-Center Hydraulic System
- 35 Gallon Hydraulic Oil Reservoir
- Padded Boom Rest with Upper Boom Tie Downs
- Boom Interlock
- Moving Outrigger Alarm
- Truck Level Indicator

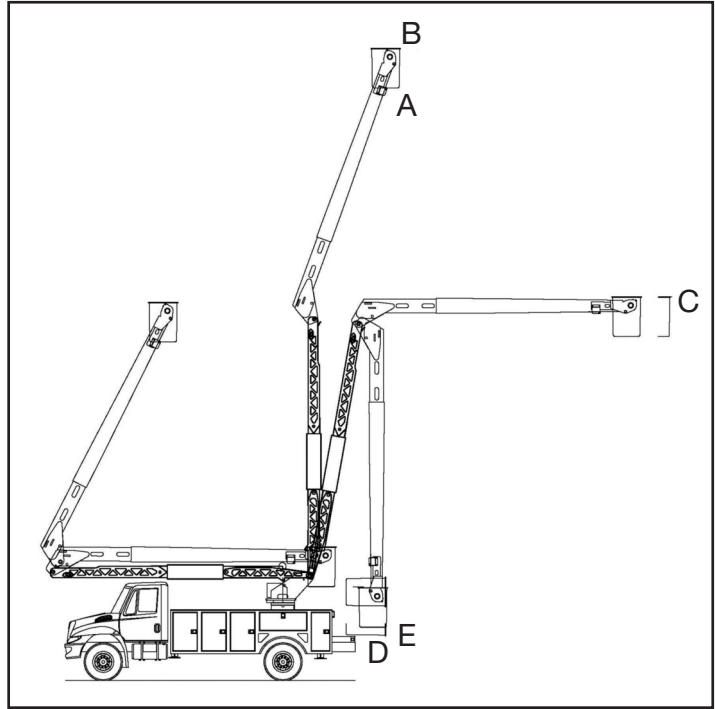

CAPACITIES & DIMENSIONAL DATA (Based on a 40 Inch Frame Height)

MODEL	A		C			
	Bottom of Platform	Working Height	Side Reach L.B. at 100°	Side Reach L.B. at 110°	Side Reach L.B. at 120°	Side Reach L.B. At 120° with Ground Access
TCX52	51.9 ft (15.8 m)	56.9 ft (17.3 m)	33.7 ft (10.2 m)	37.2 ft (11.3 m)	40.0 ft (12.2 m)	41.5 ft (12.6 m)
TCX55	54.9 ft (16.7 m)	59.9 ft (18.3 m)	35.2 ft (10.7 m)	39.2 ft (11.9 m)	42.1 ft (12.8 m)	42.6 ft (13.0 m)
TCX60	59.7 ft (18.2 m)	64.7 ft (19.7 m)	38.2 ft (11.6 m)	42.7 ft (13.0 m)	45.9 ft (14.0 m)	46.3 ft (14.1 m)

MODEL	D (Dump and rotated position)			E			
	Lip to Ground at 100°	Lip to Ground at 110°	Lip to Ground at 120°	Bottom Platform to Ground at 100°	Bottom Platform to Ground at 110°	Bottom Platform to Ground at 120°	Bottom Platform to Ground at 120° with Ground Access
TCX52	48.3 in. (122.7 cm)	35.5 in. (90.2 cm)	19.9 in. (50.5 cm)	62.2 in. (158.0 cm)	49.4 in. (125.5 cm)	33.7 in. (85.6 cm)	15.7 in. (39.9 cm)
TCX55	48.0 in. (121.9 cm)	34.4 in. (87.4 cm)	17.7 in. (45.0 cm)	61.9 in. (157.2 cm)	48.3 in. (122.7 cm)	31.6 in. (80.3 cm)	14.7 in. (37.3 cm)
TCX60	47.5 in. (120.7 cm)	32.6 in. (82.8 cm)	14.2 in. (36.1 cm)	61.5 in. (156.2 cm)	46.5 in. (118.1 cm)	28.1 in. (71.4 cm)	11.0 in. (27.9 cm)

OPTIONAL EQUIPMENT

- Two Person Side or *End Mount Platform
- Various Platform Covers
- Liners With or Without Steps
- Hydraulic Platform Rotators (180° End Mt, 90° Side Mt)
- 24" Platform Lifter
- Jib Options (Side Mount Only)
 - Various Jib Extension Systems
 - Hydraulic Articulating Jib/Winch, Side Mount 2000 lbs. (907 kg)
 - Hydraulic Articulating Jib/Winch, Underslung Mount 1500 lbs. (680 kg)
- Single Wire / 46 Kv Insulated Single Line Lifter / Multi-Phase Attachments
- Category "A" or "B" Rating Per ANSI A92.2
- 100° and 120° Optional Lower Boom Articulation
- 120° Lower Boom Articulation with Platform Ground Access
 - Adds 18" to Platform Offset, Stored Position
- Lower Boom Lifting Eye
- Automatic Upper Boom Latch
- Hydraulic Lifts: 13 ft. and 15 ft.
- Hydraulic Tool Outlets
- Pressure Compensated, Variable Volume Pumps
- Hydraulic Oil Cooler
- Engine Stop/Start
- Auxiliary Power
- Auxiliary Let Down System
- Boom Overstow Protection
- Boom/Boom Stow Interlock
- Boom Storage Warning Light
- Outrigger Sag Light
- Various Types of Outriggers
- Truck Grounding Cable & Clamp
- Hybrid Enable
- HyPower™ Hybrid System by Terex®

*End mount platform with rotator adds 16" to side reach and reduces platform lip to ground by 16" in position (D).

Effective Date: January, 2011. Product specifications and prices are subject to change without notice or obligation. The photographs and/or drawings in this document are for illustrative purposes only. Refer to the appropriate Operator's Manual for instructions on the proper use of this equipment. Failure to follow the appropriate Operator's Manual when using our equipment or to otherwise act irresponsibly may result in serious injury or death. The only warranty applicable to our equipment is the standard written warranty applicable to the particular product and sale and Terex makes no other warranty, express or implied. Products and services listed may be trademarks, service marks or trade-names of Terex Corporation and/or its subsidiaries in the USA and other countries. All rights are reserved. Terex® is a registered trademark of Terex Corporation in the USA and many other countries. Copyright 2011 Terex Corporation.