Manual # 99904677

5/33 Technical Specifications

Revision Date 20111213



IOWA MOLD TOOLING CO., INC.

PO Box 189

Garner, IA 50438

Tel: 641-923-3711 FAX: 641-923-2424

Website: <http://www.imt.com>

Copyright © 2009 Iowa Mold Tooling Co., Inc.
All rights reserved

No part of this publication may be reproduced, stored in a retrieval system, or transmitted in any form or by any means, electronic, mechanical, photocopying, recording or otherwise without the prior written permission of Iowa Mold Tooling Co., Inc.

Iowa Mold Tooling Co., Inc. is an Oshkosh Corporation company.

Contents

Revisions	ii
Technical Data and Charts	3
5/33 Specifications.....	4
5/33 Pressure Settings.....	5
5/33 K1 Capacity Chart	6
5/33 K2 Capacity Chart	7
5/33 K3 Capacity Chart	8
5/33 K4 Capacity Chart	9
5-33 Geometric Configuration.....	10
Hydraulic Schematics	11
Hydraulic Diagram - 5/33 Loader Functions	12
Hydraulic Diagram - 5/33 with Extra Valves	13
Hydraulic Diagram - 5/33 with Winch	14
Hydraulic Diagram - 5/33 Hydrocontrol M50 - Radio	15
Hydraulic Diagram - 5/33 Danfoss PVG32	16

Revisions

DATE	LOCATION	DESCRIPTION
20111213		ECN 11628 – Update stabilizer wording.

CHAPTER 1

Technical Data and Charts

In This Chapter

5/33 Specifications	3
5/33 Pressure Settings	5
5/33 K1 Capacity Chart	5
5/33 K2 Capacity Chart	7
5/33 K3 Capacity Chart	8
5/33 K4 Capacity Chart	9
5-33 Geometric Configuration	10

5/33 Specifications

5/33	1-HYDRAULIC	2-HYDRAULIC	3-HYDRAULIC	4-HYDRAULIC
Crane Rating*	32,550 ft-lb (4.5 tm)	31,825 ft-lb (4.4 tm)	30,380 ft-lb (4.2 tm)	29,655 ft-lb (4.1 tm)
Maximum Horizontal Reach	16' 1" (4.9 m)	21' 0" (6.4 m)	26' 3" (8.0 m)	31' 6" (9.6 m)
Maximum Vertical Reach	23' 0" (7.0 m)	27' 11" (8.5 m)	32' 9" (10.0 m)	37' 7" (11.5 m)
Maximum Capacity	2975 lb (1350 kg)	2820 lb (1280 kg)	2645 lb (1200 kg)	2515 lb (1140 kg)
Max Cap @ Max Reach	2070 lb (940 kg)	1475 lb (670 kg)	1100 lb (500 kg)	825 lb (375 kg)
Crane Weight **	1255 lb (569 kg)	1375 lb (624 kg)	1475 lb (669 kg)	1555 lb (705 kg)
Hook Approach				
Vertical	7' 1" (2.16 m)	6' 9" (2.06 m)	6' 5" (1.96 m)	6' 1" (1.85 m)
Horizontal	2' 9" (0.84 m)	2' 11" (0.89 m)	3' 1" (0.94 m)	3' 3" (1.0 m)
Center of Gravity - Stored				
Vertical	1' 7" (475 mm)	1' 7" (493 mm)	1' 8" (506 mm)	1' 8" (518 mm)
Horizontal (C/L RotTo Bridge)	7.8" (198 mm)	7.4" (187 mm)	6.7" (171 mm)	6.0" (152 mm)

* Crane rating (ft-lb) is the rated load (lb) multiplied by the respective distance (ft) from centerline of rotation with all extensions retracted and the inner and outer booms in a horizontal position, per ANSI B30.22. ** Crane weight does not include stabilizers.

5/33 SPECIFICATIONS	
Stabilizer Pad Diameter	5.5" (140 mm)
Crane Storage Height	5' 9" (1750 mm)
Mounting Space	1' 9" (530 mm)
Rotational Torque	5065 ft-lb (700 kgm)
Rotation	400°
Optimum Pump Performance	6.6 gpm (25 lpm)
System Pressure	3915 psi (270 bar)
Oil Reservoir Capacity	6 gal (23 l)
Stabilizer Extension Span	
Standard (manual out /hydraulic down)	9' 11" (3025 mm)
Weight	220 lb (100 kg)
Option 1 (manual out / hyd. down)	13' 7" (4145 mm)
Weight	265 lb (120 kg)
Option 2 (hyd. out / hyd. down)	16' 2" (4925 mm)
Weight	320 lb (145 kg)
*** Maximum swing clearance radius required is 20.5" (516 mm) at 6'-9" (2055 mm) from top of chassis frame.	

MINIMUM CHASSIS SPECIFICATIONS	
Front Axle Rating (GAWR)	5000 lb (2270 kg)
Rear Axle Rating (GAWR)	9500 lb (4310 kg)
Resistance To Bending Moment	440,000 in-lb (50,695 kg-m)

5/33 Pressure Settings

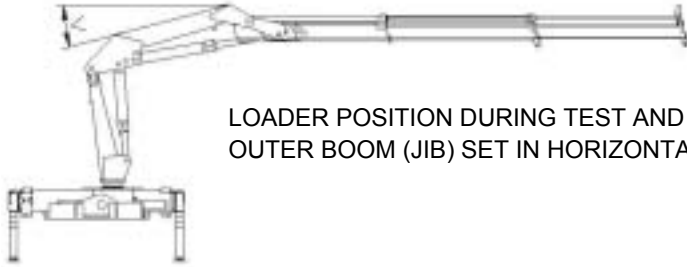

LOADER POSITION DURING TEST AND VALVE ADJUSTMENT:
OUTER BOOM (JIB) SET IN HORIZONTAL POSITION, V AT 15 DEG.

WORKING PRESSURE ON MAIN-RELIEF VALVES & PORT-RELIEF VALVES

Function	Direction	Port	Pressure (Loading Group 03)
Main-Relief Valve			3915 psi (270 bar)
Stabilizers / Grab / Rotator	Down	A-port	2540 psi (175 bar)
	Up	B-port	2540 psi (175 bar)
	Down	A-port	2540 psi (175 bar)
	Up	B-port	2540 psi (175 bar)
Extension Cylinders	Extend	A-port	P
	Retract	B-port	P
Jib Cylinder	Down	A-port	2900 psi (200 bar)
	Up	B-port	4205 psi (290 bar)
Boom Cylinder	Up	A-port	4205 psi (290 bar)
	Down	B-port	1450 psi (100 bar)
Rotation System	Right	A-port	2175 psi (150 bar)
	Left	B-port	2175 psi (150 bar)
Winch (Pullmaster PL1)	Retract	A-port	2030 psi (140 bar)
	Extend	B-port	2030 psi (140 bar)
Winch (Pullmaster PL2)	Retract	A-port	2250 psi (155 bar)
	Extend	B-port	2250 psi (155 bar)
Separate Stabilizer Valve			2175 bar (150 bar)

OPENING PRESSURE ON LOAD-HOLDING VALVES

Boom Cylinder	4350 psi (300 bar)
Jib Cylinder	4425 psi (305 bar)
Extension Cylinder	3045 psi (210 bar)
Re-generation	6235 psi (430 bar)

PRESSURE SETTING

Pressure Setting for Load-Moment Limitation	3770 psi (260 bar)
---	--------------------

MAXIMUM PUMP PERFORMANCE

Pump Performance 5/33 K1 & K2	6.6 gpm (25 l/min)
Pump Performance 5/33 K3 & K4	5.3 gpm (20 l/min)

Note: On Hydrocontrol M50, the A-port is located next to the control lever.

5/33 K1 Capacity Chart

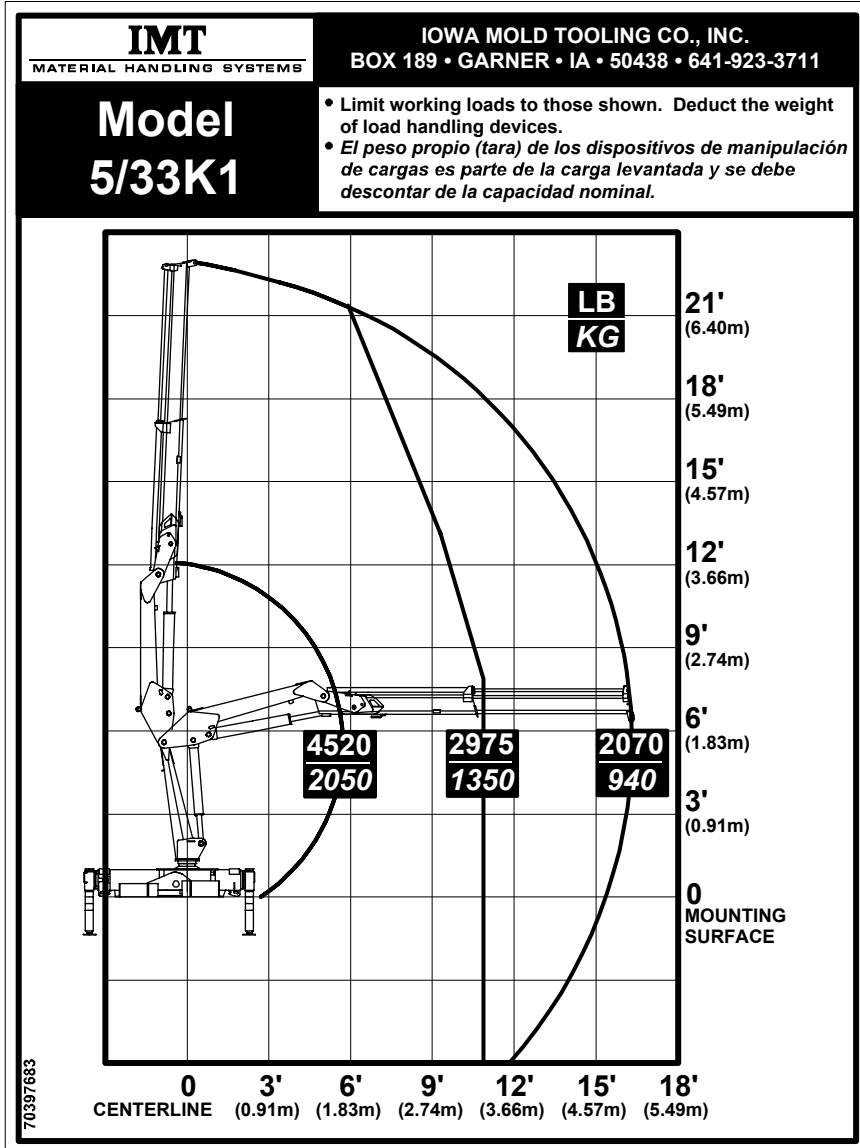

5/33 K2 Capacity Chart

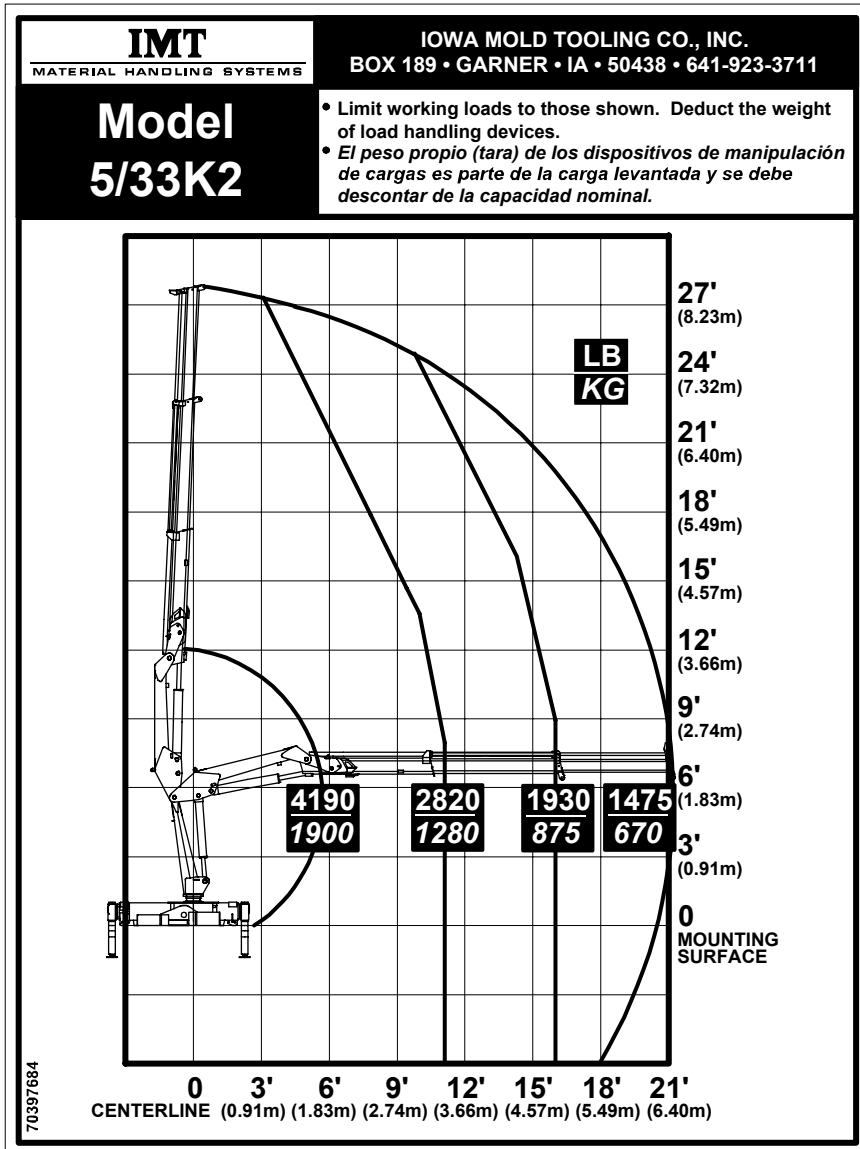

5/33 K3 Capacity Chart

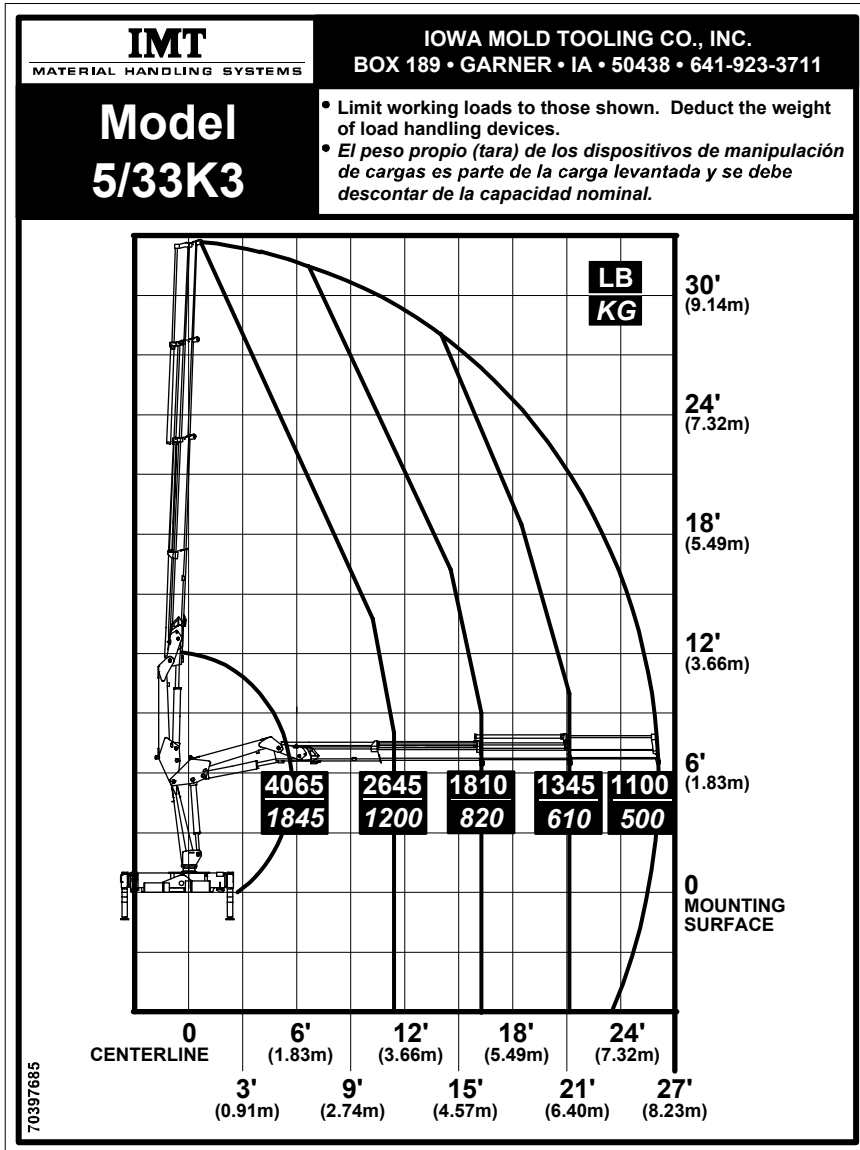

5/33 K4 Capacity Chart

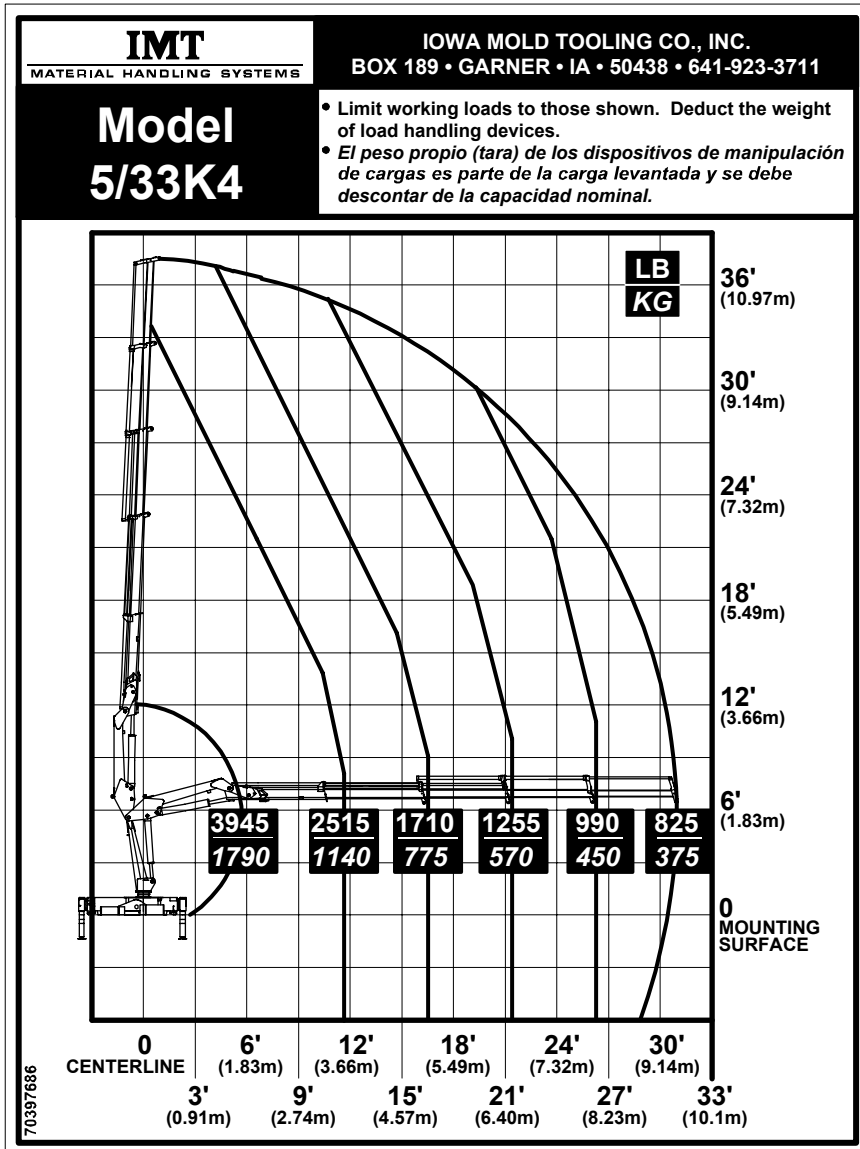

5-33 Geometric Configuration

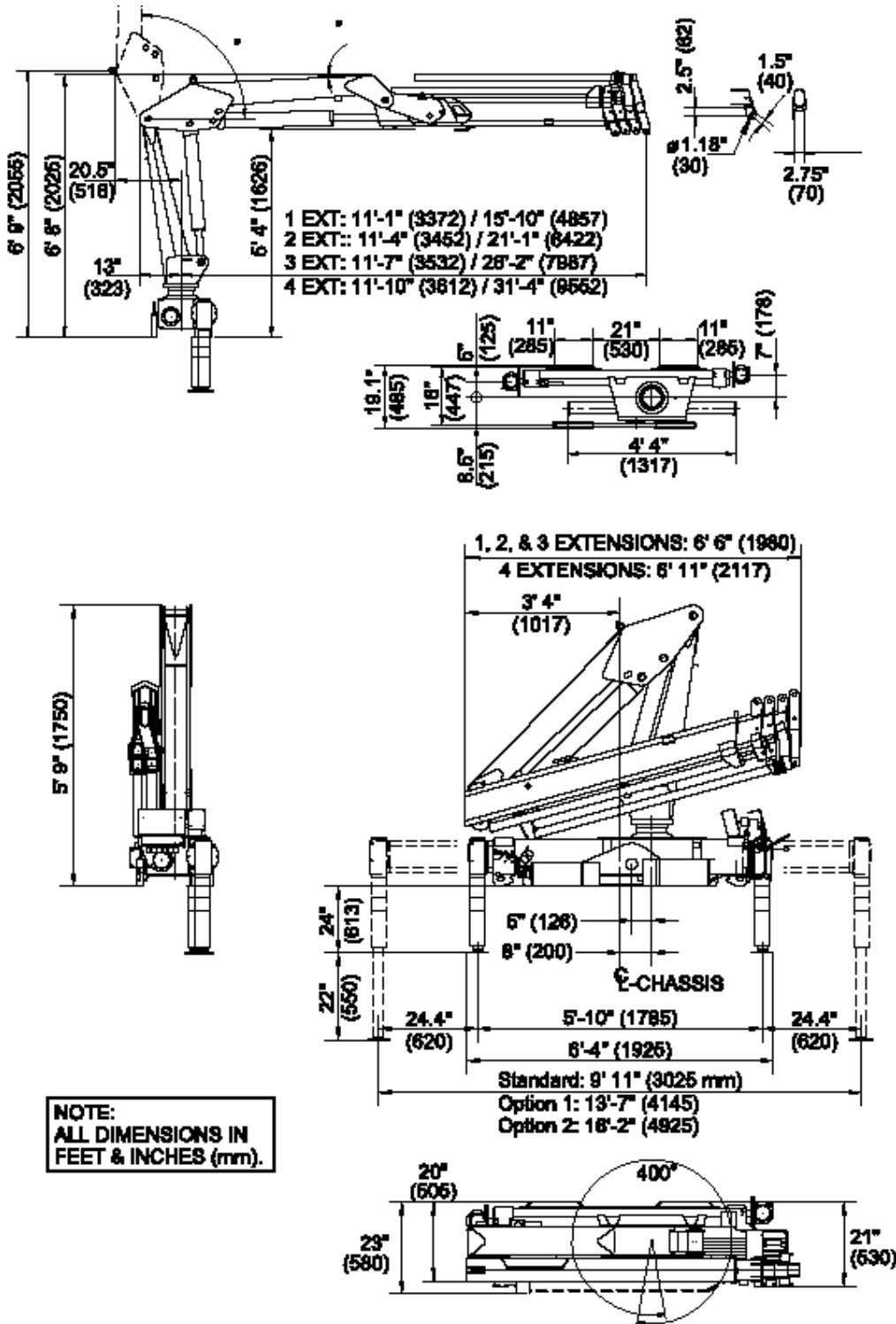

CHAPTER 2

Hydraulic Schematics

In This Chapter

Hydraulic Diagram - 5/33 Loader Functions	12
Hydraulic Diagram - 5/33 with Extra Valves	13
Hydraulic Diagram - 5/33 with Winch	14
Hydraulic Diagram - 5/33 Hydrocontrol M50 - Radio.....	15
Hydraulic Diagram - 5/33 Danfoss PVG32.....	16

Hydraulic Diagram - 5/33 Loader Functions

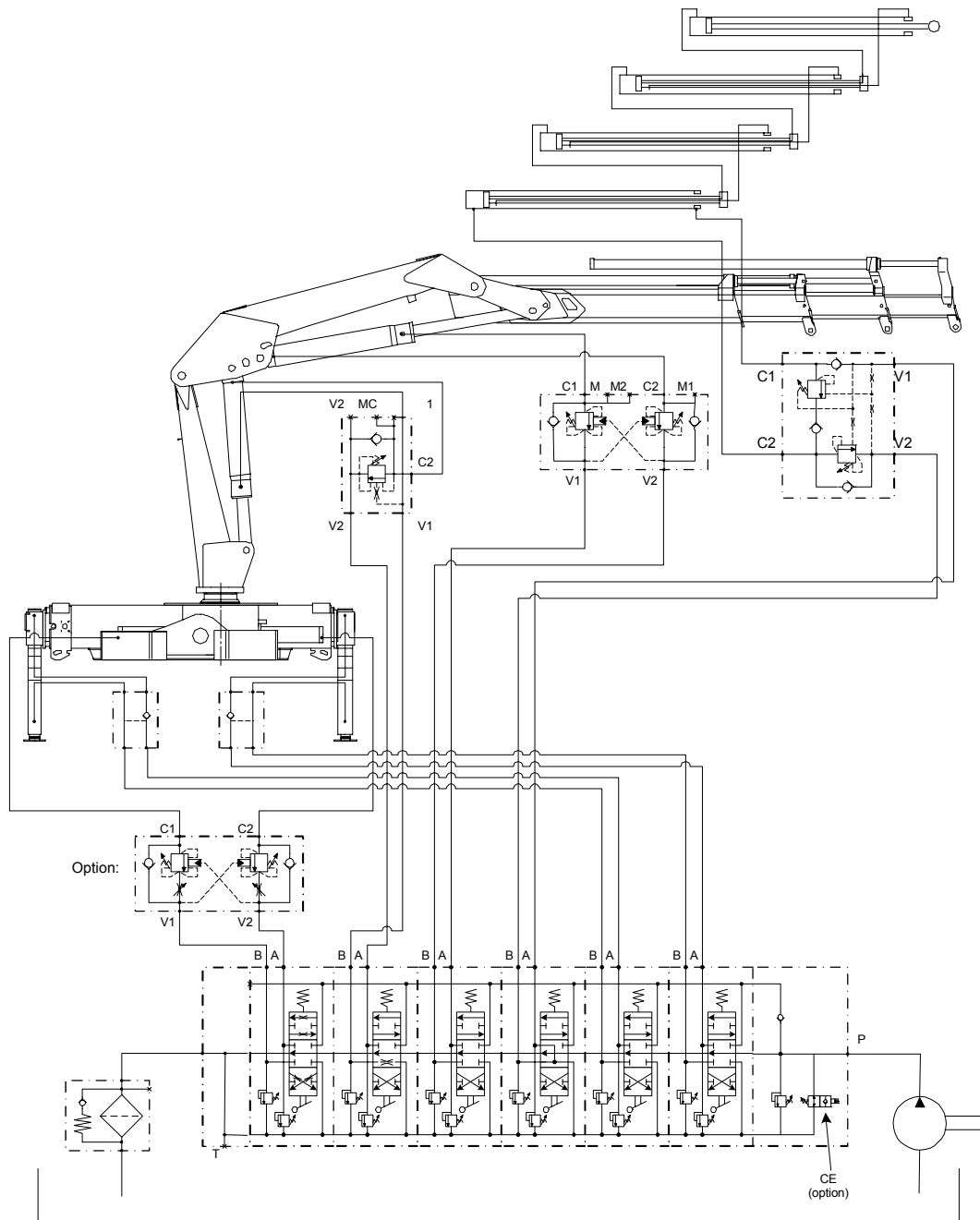

Hydraulic Diagram - 5/33 with Extra Valves

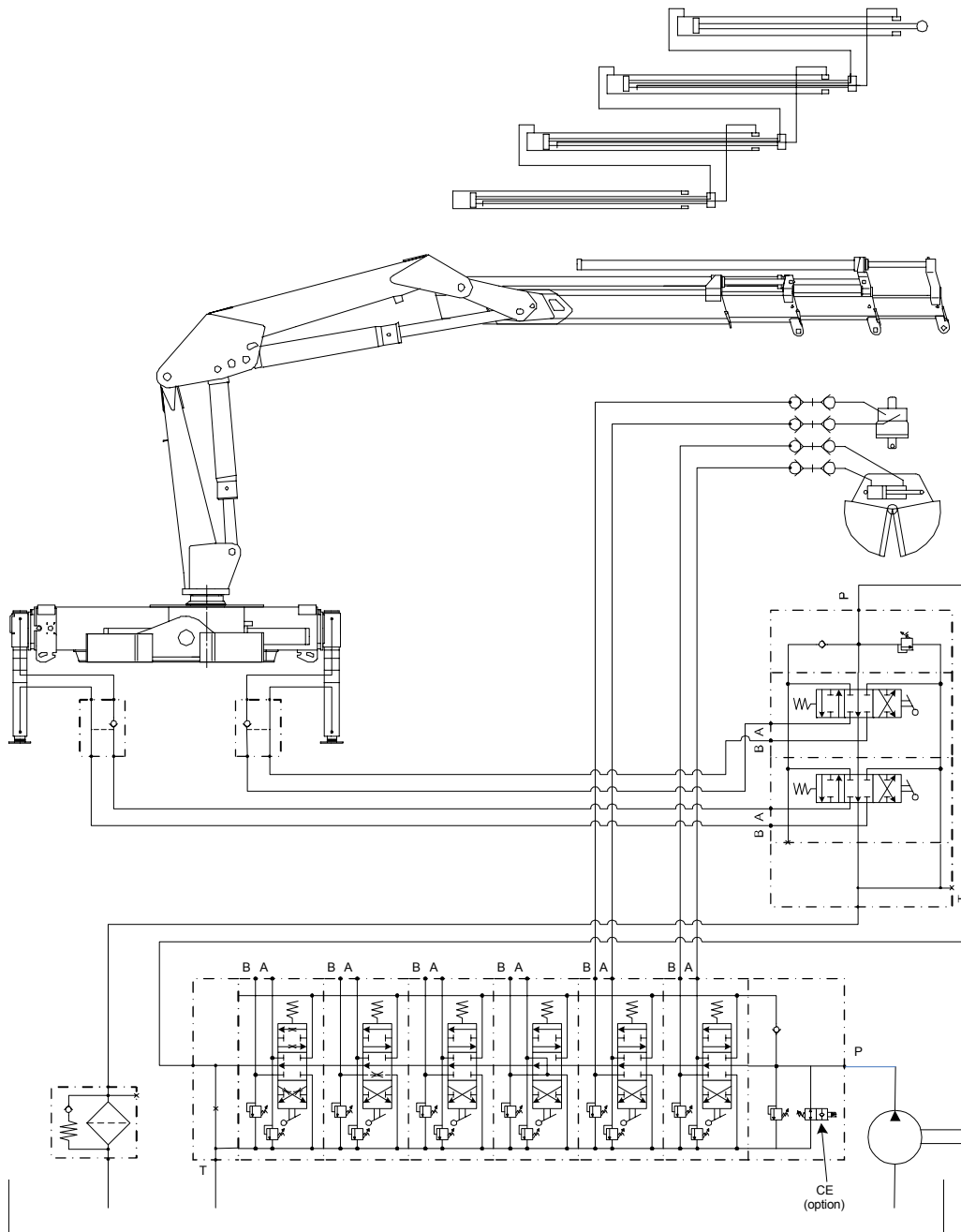

Hydraulic Diagram - 5/33 with Winch

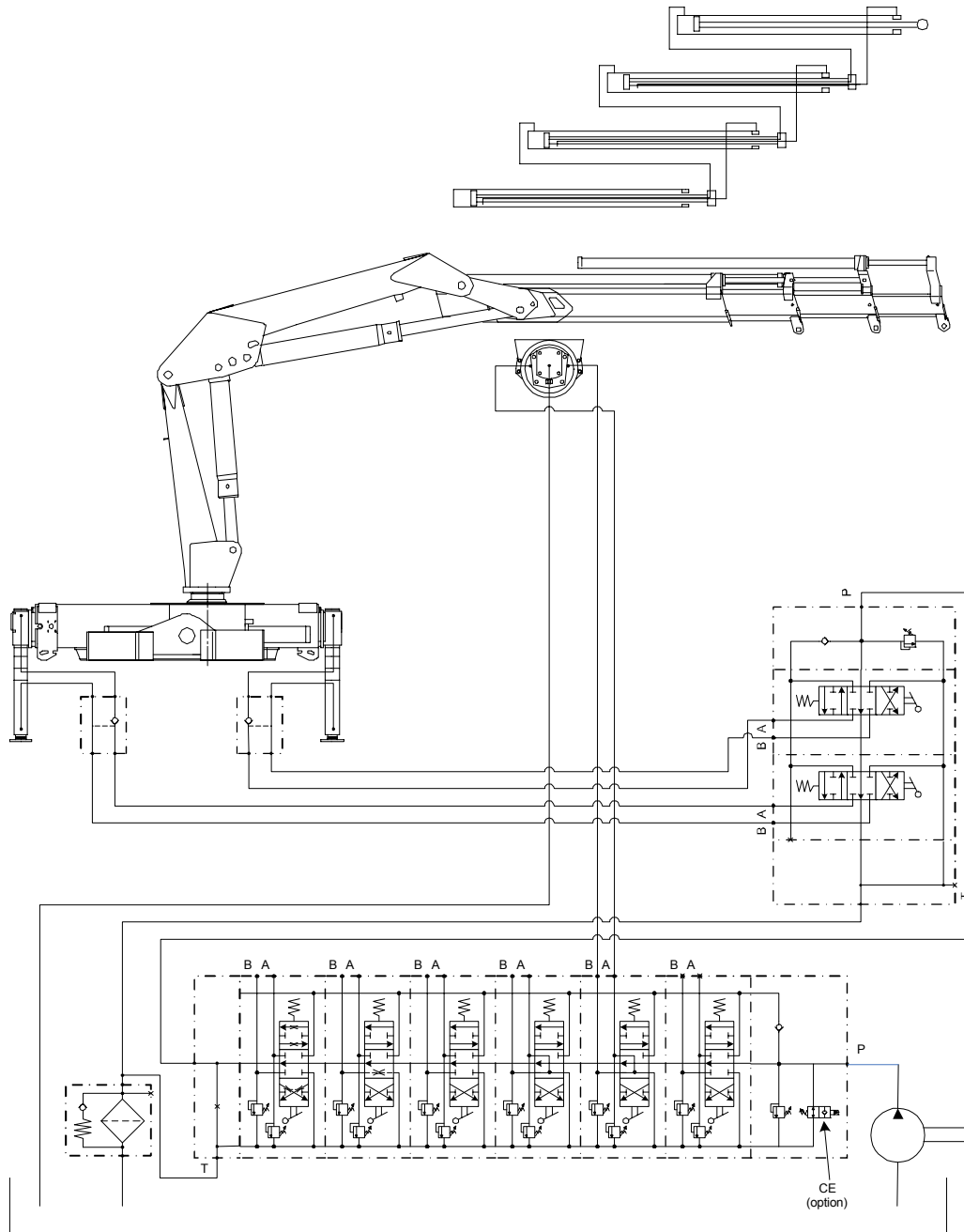

Hydraulic Diagram - 5/33 Hydrocontrol M50 - Radio

