

1 Schedule drawing

1.1 Schedule drawing WOLFF 8033.20cross

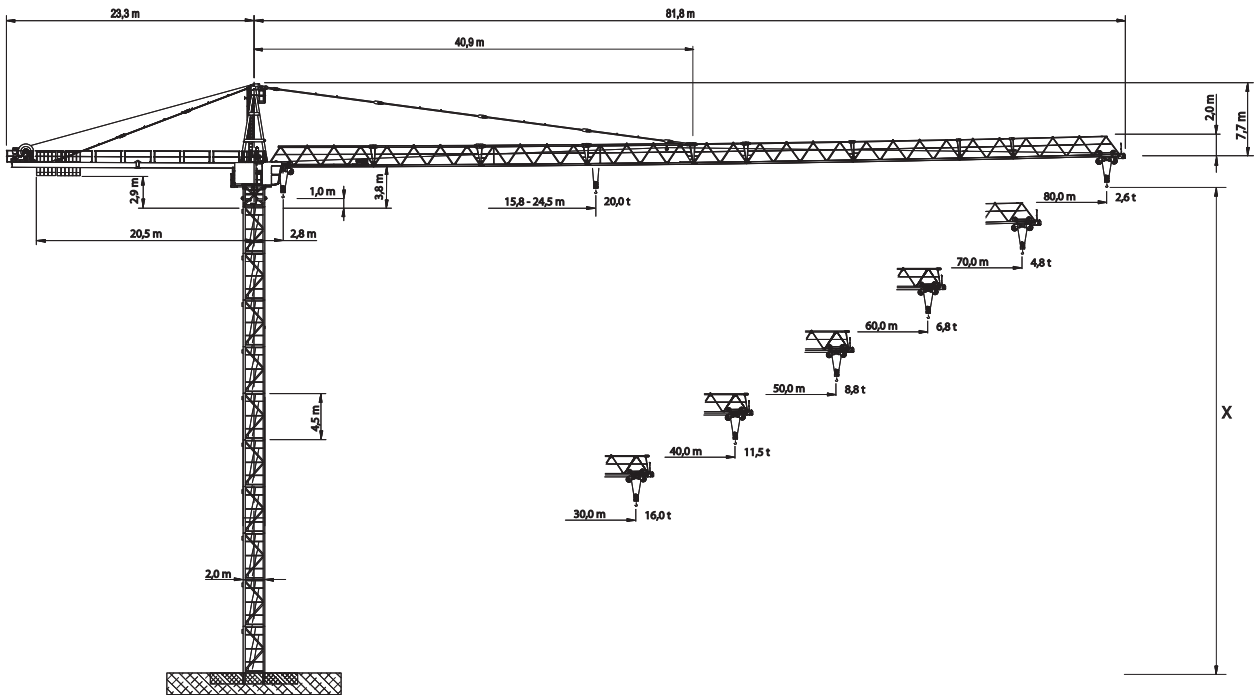

[X] max. hook height above ground

Data WOLFF 8033.20

Item	Data
Crane type	BGL GROUP C.0.10.0450
Design	Overhead travelling crane with top slewing trolley jib, with climbing feature
Type of setup	Stationary or travelling
Basis of calculation	EN
Payload torque	max. 4900 kN/m
Hoist winch	Hw 2075 FU / Hw 20110 FU

2 Load carrying capacities

2.1 Table of load carrying capacity WOLFF 8033.20 (double reeving)

 20.0 t		Operating radius [m]	30	35	40	45	50	55	60	65	70	75	80	LCC
JL [m]	80	2.8 – 15.8	9.8	8.1	6.9	5.9	5.2	4.6	4.0	3.6	3.2	2.9	2.6	LCC
	77.5	2.8 -17.5	10.9	9.1	7.8	6.7	5.9	5.2	4.6	4.1	3.7	3.4		
	75	2.8 – 19.0	12.0	10.1	8.6	7.5	6.6	5.8	5.2	4.6	4.2	3.8		
	72.5	2.8 -20.0	12.8	10.7	9.2	8.0	7.0	6.2	5.6	5.0	4.5			
	70	2.8 – 21.0	13.5	11.3	9.7	8.4	7.4	6.6	5.9	5.3	4.8			
	67.5	2.8 -21.8	14.0	11.8	10.1	8.8	7.8	6.9	6.2	5.6				
	65	2.8 – 22.5	14.5	12.2	10.5	9.1	8.1	7.2	6.4	5.8				
	62.5	2.8 -23.0	15.0	12.6	10.8	9.4	8.3	7.4	6.6					
	60	2.8 – 23.5	15.3	12.9	11.1	9.6	8.5	7.6	6.8					
	57.5	2.8 -23.8	15.5	13.1	11.2	9.8	8.7	7.7						
	55	2.8 – 24.1	15.7	13.2	11.4	9.9	8.8	7.8						
	52.5	2.8 -24.2	15.8	13.3	11.4	10.0	8.8							
	50	2.8 – 24.2	15.8	13.3	11.4	10.0	8.8							
	47.5	2.8 -24.3	15.9	13.4	11.5	10.0								
	45	2.8 – 24.3	15.9	13.3	11.5	10.0								
	42.5	2.8 -24.3	15.9	13.4	11.5									
	40	2.8 – 24.3	15.9	13.4	11.5									
	37.5	2.8 -24.4	15.9	13.4										
	35	2.8 – 24.4	15.9	13.4										
	32.5	2.8 – 24.4	16.0											
30	2.8 – 24.5	16.0												



Caption

JL	Jib length
LCC	Load carrying capacity

2.2 Table of load carrying capacities (kg) in meter intervals, WOLFF 8033.20 (20.0t, double reeving)

Operating radius [m]	Jib length [m]																				
	30	32.5	35	37.5	40	42.5	45	47.5	50	52.5	55	57.5	60	62.5	65	67.5	70	72.5	75	77.5	80
25	19540	19490	19440	19450	19410	19370	19350	19380	19290	19290	19190	18990	18690	18290	17780	17180	16480	15680	14780	13470	12040
26	18720	18670	18620	18630	18600	18560	18540	18570	18480	18480	18390	18190	17900	17520	17040	16460	15780	15010	14150	12890	11510
27	17970	17920	17870	17880	17850	17810	17790	17820	17740	17740	17640	17460	17180	16810	16340	15790	15140	14390	13560	12350	11020
28	17260	17220	17170	17180	17150	17120	17100	17120	17040	17040	16950	16770	16500	16140	15700	15160	14540	13820	13020	11840	10570
29	16610	16570	16520	16530	16500	16470	16450	16470	16400	16400	16310	16140	15880	15530	15100	14580	13980	13290	12510	11380	10140
30	16000	15960	15920	15920	15900	15860	15850	15870	15790	15790	15710	15540	15290	14960	14540	14040	13450	12790	12040	10940	9750
31		15390	15350	15350	15330	15300	15280	15300	15230	15230	15150	14990	14740	14420	14010	13530	12960	12320	11590	10540	9380
32		14850	14810	14820	14800	14770	14750	14770	14700	14700	14620	14460	14230	13920	13520	13050	12510	11880	11180	10150	9040
32.5		14600	14560	14570	14540	14510	14500	14520	14450	14450	14370	14220	13980	13680	13290	12830	12290	11670	10980	9970	8870
33			14310	14320	14300	14270	14250	14270	14200	14200	14130	13970	13750	13440	13060	12610	12080	11470	10790	9790	8710
34			13840	13850	13830	13800	13780	13800	13740	13740	13660	13510	13290	13000	12630	12190	11670	11080	10420	9460	8400
35			13400	13410	13380	13360	13340	13360	13300	13300	13220	13080	12860	12580	12220	11790	11290	10720	10070	9140	8120
36				12990	12970	12940	12920	12940	12880	12880	12810	12670	12460	12180	11830	11420	10930	10370	9750	8840	7840
37				12590	12570	12540	12530	12550	12490	12490	12420	12280	12080	11810	11470	11060	10590	10050	9440	8550	7590
37.5				12400	12380	12350	12340	12360	12300	12300	12230	12090	11890	11630	11290	10890	10420	9890	9290	8420	7460
38				12190	12170	12150	12170	12110	12110	12050	11910	11720	11450	11120	10730	10270	9740	9150	8280	7340	
39				11840	11810	11800	11820	11760	11760	11690	11560	11370	11110	10790	10410	9960	9450	8870	8030	7110	
40				11500	11470	11460	11480	11420	11420	11360	11230	11050	10790	10480	10110	9670	9170	8600	7780	6890	
41					11150	11140	11160	11100	11100	11040	10920	10730	10490	10180	9820	9390	8900	8350	7550	6680	
42					10850	10840	10850	10800	10800	10740	10620	10440	10200	9900	9540	9130	8650	8110	7330	6480	
42.5					10700	10690	10700	10650	10650	10590	10470	10300	10060	9770	9410	9000	8530	8000	7230	6390	
43						10540	10560	10510	10510	10450	10330	10160	9920	9630	9280	8880	8410	7890	7120	6290	
44						10270	10280	10230	10230	10170	10060	9890	9660	9370	9030	8640	8180	7670	6920	6110	
45						10000	10020	9970	9970	9910	9800	9630	9410	9130	8800	8410	7960	7460	6730	5940	
46							9760	9710	9710	9660	9550	9380	9170	8890	8570	8190	7750	7260	6550	5770	
47							9520	9470	9470	9420	9310	9150	8940	8670	8350	7980	7550	7070	6370	5610	
47.5							9400	9350	9350	9300	9190	9030	8820	8560	8240	7870	7450	6980	6290	5540	
48								9240	9240	9180	9080	8920	8710	8450	8140	7770	7360	6890	6210	5460	
49								9010	9010	8960	8860	8710	8500	8250	7940	7580	7170	6710	6040	5310	
50								8800	8800	8750	8650	8500	8300	8050	7750	7400	7000	6550	5890	5170	
51									8590	8540	8450	8300	8100	7860	7560	7220	6830	6380	5740	5040	
52									8400	8350	8250	8110	7910	7670	7380	7050	6660	6230	5600	4910	
52.5									8300	8250	8160	8010	7820	7580	7300	6960	6580	6150	5530	4850	
53										8160	8060	7920	7730	7500	7210	6880	6500	6080	5460	4790	
54										7980	7880	7740	7560	7330	7050	6720	6350	5940	5330	4670	
55										7800	7710	7570	7390	7160	6890	6570	6210	5800	5200	4550	
56											7540	7410	7230	7000	6740	6420	6060	5660	5080	4440	
57											7380	7250	7070	6850	6590	6280	5930	5530	4960	4330	
57.5											7300	7170	6990	6780	6520	6210	5860	5470	4900	4280	
58												7090	6920	6700	6440	6140	5800	5410	4840	4230	
59												6940	6770	6560	6310	6010	5670	5290	4730	4130	
60												6800	6630	6420	6170	5880	5550	5170	4630	4030	
61													6500	6290	6040	5760	5430	5060	4520	3940	
62														6360	6160	5920	5640	5310	4950	4420	3850
62.5														6300	6100	5860	5580	5260	4900	4370	3800
63															6040	5800	5520	5200	4850	4330	3760
64																5920	5680	5410	5100	4740	4230
65															5800	5570	5300	4990	4640	4140	3590
66																5460	5190	4890	4550	4050	3510
67																5350	5090	4790	4460	3970	3430
67.5																5300	5040	4740	4410	3920	3390
68																	4990	4700	4370	3880	3360
69																	4890	4600	4280	3800	3280
70																	4800	4510	4190	3720	3210
71																		4430	4110	3650	3140
72																		4340	4030	3570	3080
72.5																		4300	3990	3540	3040
73																			3950	3500	3010
74																			3870	3430	2950
75																			3800	3360	2890
76																				3300	2830
77																				3230	2770
77.5																				3200	2740
78																					2710
79																					2650
80																					2600

3 Tower combinations

	<p>⚠ DANGER</p> <p>Usage of incorrect tower combinations. The slewing tower crane may overturn.</p> <ol style="list-style-type: none">1) Use the specified tower combinations.2) If you need another tower combination that is not specified here, please contact WOLFFKRAN to get an approved alternative setup in writing.
	<p>NOTICE</p> <p>All tower combinations apply to free standing slewing tower cranes without climbing gear.</p>
	<p>NOTICE</p> <p>For tower combination with tower element TV 25 and UV 25 please contact WOLFFKRAN.</p>

3.1 Tower combinations on foundation anchor (TV 20 - connection)

Jib length	30 m – 80 m			
Item				
1	4.5 m	TV 20.4		
2	9.0 m	TV 20.4		
3	13.5 m	TV 20.4		
4	18.0 m	TV 20.4		
5	22.5 m	TV 20.4		
6	27.0 m	TV 20.4		
7	31.5 m	TV 20.4		
8	36.0 m	TV 20.4		
9	40.5 m	TV 20.4		
10	45.0 m	TV 20.4		
11	49.5 m	TV 20.4		
12	54.0 m	TV 20.4		
Foundation anchor		TYPE D -140/ FUA 140		
Tower height [m]		54.0		
Hook height double reeving [m]		55.0		

WOLFFKRAN

Jib length	30 m – 80 m				
Item					
1	4.5 m	TV 20.4			
2	9.0 m	TV 20.4			
3	13.5 m	TV 20.4			
4	18.0 m	TV 20.4			
5	22.5 m	TV 20.4			
6	27.0 m	TV 20.4			
7	31.5 m	TV 20.4			
8	36.0 m	TV 20.4			
9	40.5 m	TV 20.4			
10	45.0 m	TV 20.4			
11	49.5 m	TV 20.4			
12	50.5 m	VR 2023			
13	55.0 m	TV 23			
14	59.5 m	TV 23			
Foundation anchor		TYPE D-140 / FUA 140			
Tower height [m]		59.5			
Hook height double reeving [m]		60.5			

WOLFFKRAN

Jib length	30 m – 80 m			
Item				
1	4.5 m	TV 20.4		
2	9.0 m	TV 20.4		
3	13.5 m	TV 20.4		
4	18.0 m	TV 20.4		
5	22.5 m	TV 20.4		
6	27.0 m	TV 20.4		
7	31.5 m	TV 20.4		
8	36.0 m	TV 20.4		
9	40.5 m	TV 20.4		
10	45.0 m	TV 20.4		
11	46.0 m	VR 2023		
12	50.5 m	TV 23		
13	55.0 m	TV 23		
14	59.5 m	HTA 23		
15	64.0 m	HT 23		
16	68.5 m	HT 23		
17	73.0 m	HT 23		
Foundation anchor		FUA G 160		
Tower height [m]		73.0		
Hook height double reeving [m]		74.0		

WOLFFKRAN

Jib length	30 m – 80 m			
Item				
1	4.5 m	TV 20.4		
2	9.0 m	TV 20.4		
3	13.5 m	TV 20.4		
4	18.0 m	TV 20.4		
5	22.5 m	TV 20.4		
6	27.0 m	TV 20.4		
7	31.5 m	TV 20.4		
8	36.0 m	TV 20.4		
9	40.5 m	TV 20.4		
10	41.5 m	VR 2023		
11	46.0 m	TV 23		
12	50.5 m	TV 23		
13	55.0 m	HTA 23		
14	59.5 m	HT 23		
15	64.0 m	HT 23		
16	68.5 m	HT 23		
17	79.8 m	BT 23		
Foundation anchor		FUA G 210		
Tower height [m]		79.8		
Hook height double reeving [m]		80.8		

WOLFFKRAN

Jib length	30 m – 80 m			
Item				
1	4.5 m	TV 20.4		
2	9.0 m	TV 20.4		
3	13.5 m	TV 20.4		
4	18.0 m	TV 20.4		
5	22.5 m	TV 20.4		
6	27.0 m	TV 20.4		
7	31.5 m	TV 20.4		
8	36.0 m	TV 20.4		
9	40.5 m	TV 20.4		
10	41.5 m	VR 2023		
11	46.0 m	TV 23		
12	50.5 m	TV 23		
13	55.0 m	HTA 23		
14	59.5 m	HT 23		
15	64.0 m	HT 23		
16	68.5 m	HT 23		
17	69.7 m	VR 23/25-29		
18	74.2 m	UV 29		
19	84.2 m	BT 29		
Foundation anchor		FUA BT 29		
Tower height [m]		84.2		
Hook height double reeving [m]		85.2		

3.2 Tower combinations on foundation anchor (HT23 - connection)

Jib length		30 m – 80 m			
Item					
1	4.5 m	HT 23			
2	9.0 m	HT 23			
3	13.5 m	HT 23			
4	18.0 m	HT 23			
5	22.5 m	HT 23			
6	27.0 m	HT 23			
7	31.5 m	HT 23			
8	36.0 m	HT 23			
9	40.5 m	HT 23			
10	45.0 m	HT 23			
11	49.5 m	HT 23			
12	54.0 m	HT 23			
13	58.5 m	HT 23			
14	63.0 m	HT 23			
15	67.5 m	HT 23			
16	78.8 m	BT 23			
Foundation anchor		FUA G 210			
Tower height [m]		78.8			
Hook height double reeving [m]		79.8			

3.3 Tower combinations on cross frame (TV 20 - connection)

Jib length	30 m – 80 m			
Item				
1	4.5 m	TV 20.4		
2	9.0 m	TV 20.4		
3	13.5 m	TV 20.4		
4	18.0 m	TV 20.4		
5	22.5 m	TV 20.4		
6	27.0 m	TV 20.4		
7	31.5 m	TV 20.4		
8	36.0 m	TV 20.4		
9	40.5 m	TV 20.4		
10	45.0 m	TV 20.4		
11	49.5 m	TV 20.4		
12	54.0 m	TV 20.4		
Substructure		KR 12-60 / KR 12-60/80		
[m x m]		6.0 x 6.0 8.0 x 8.0		
Substructure height [m]		1.4		
Tower height [m]		55.4		
Hook height double reeving [m]		56.4		

WOLFFKRAN

Jib length	30 m – 80 m				
Item					
1	4.5 m	TV 20.4			
2	9.0 m	TV 20.4			
3	13.5 m	TV 20.4			
4	18.0 m	TV 20.4			
5	22.5 m	TV 20.4			
6	27.0 m	TV 20.4			
7	31.5 m	TV 20.4			
8	36.0 m	TV 20.4			
9	40.5 m	TV 20.4			
10	45.0 m	TV 20.4			
11	49.5 m	TV 20.4			
12	50.5 m	VR 2023			
13	55.0 m	TV 23			
14	59.5 m	TV 23			
Substructure		KR 12-60 / KR 12-60/80			
[m x m]		6.0 x 6.0 8.0 x 8.0			
Substructure height [m]		1.4			
Tower height [m]		60.9			
Hook height double reeving [m]		61.9			

Jib length	30 m – 80 m			
Item				
1	4.5 m	TV 20.4		
2	9.0 m	TV 20.4		
3	13.5 m	TV 20.4		
4	18.0 m	TV 20.4		
5	22.5 m	TV 20.4		
6	27.0 m	TV 20.4		
7	31.5 m	TV 20.4		
8	36.0 m	TV 20.4		
9	40.5 m	TV 20.4		
10	45.0 m	TV 20.4		
11	46.0 m	VR 2023		
12	50.5 m	TV 23		
13	55.0 m	TV 23		
14	59.5 m	HTA 23		
15	64.0 m	HT 23		
16	68.5 m	HT 23		
Substructure		KR 12-60 / KR 12-60/80		
[m x m]		6.0 x 6.0 8.0 x 8.0		
Substructure height [m]		1.4		
Tower height [m]		69.9		
Hook height double reeving [m]		70.9		

WOLFFKRAN

Jib length	30 m – 80 m			
Item				
1	4.5 m	TV 20.4		
2	9.0 m	TV 20.4		
3	13.5 m	TV 20.4		
4	18.0 m	TV 20.4		
5	22.5 m	TV 20.4		
6	27.0 m	TV 20.4		
7	31.5 m	TV 20.4		
8	36.0 m	TV 20.4		
9	40.5 m	TV 20.4		
10	45.0 m	TV 20.4		
11	46.0 m	VR 2023		
12	50.5 m	TV 23		
13	55.0 m	TV 23		
14	59.5 m	HTA 23		
15	64.0 m	HT 23		
16	68.5 m	HT 23		
Substructure		KR 16-80 / KR 16-80/100		
[m x m]		8.0 x 8.0 10.0 x 10.0		
Substructure height [m]		1.8		
Tower height [m]		70.3		
Hook height double reeving [m]		71.3		

WOLFFKRAN

Jib length	30 m – 80 m			
Item				
1	4.5 m	TV 20.4		
2	9.0 m	TV 20.4		
3	13.5 m	TV 20.4		
4	18.0 m	TV 20.4		
5	22.5 m	TV 20.4		
6	27.0 m	TV 20.4		
7	31.5 m	TV 20.4		
8	36.0 m	TV 20.4		
9	40.5 m	TV 20.4		
10	41.5 m	VR 2023		
11	46.0 m	TV 23		
12	50.5 m	TV 23		
13	55.0 m	HTA 23		
14	59.5 m	HT 23		
15	64.0 m	HT 23		
16	68.5 m	HT 23		
17	69.7 m	VR 23/25-29		
18	79.7 m	BT 29		
Substructure		KR 16-80		
[m x m]		8.0 x 8.0		
Substructure height [m]		1.8		
Tower height [m]		81.5		
Hook height double reeving [m]		82.5		

WOLFFKRAN

Jib length		30 m – 80 m			
Item					
1	4.5 m	TV 20.4			
2	9.0 m	TV 20.4			
3	13.5 m	TV 20.4			
4	18.0 m	TV 20.4			
5	22.5 m	TV 20.4			
6	27.0 m	TV 20.4			
7	31.5 m	TV 20.4			
8	36.0 m	TV 20.4			
9	40.5 m	TV 20.4			
10	41.5 m	VR 2023			
11	46.0 m	TV 23			
12	50.5 m	TV 23			
13	55.0 m	HTA 23			
14	59.5 m	HT 23			
15	64.0 m	HT 23			
16	68.5 m	HT 23			
17	69.7 m	VR 23/25-29			
18	74.2 m	UV 29			
19	84.2 m	BT 29			
Substructure		KR 16-80/100			
[m x m]		10.0 x 10.0			
Substructure height [m]		1.8			
Tower height [m]		86.0			
Hook height double reeving [m]		87.0			

3.4 Tower combinations on cross frame element (TV 20 - connection)

Jib length	30 m – 80 m			
Item				
1	4.5 m	TV 20.4		
2	9.0 m	TV 20.4		
3	13.5 m	TV 20.4		
4	18.0 m	TV 20.4		
5	22.5 m	TV 20.4		
6	27.0 m	TV 20.4		
Substructure		KRE 260.2		
[m x m]		6.0 x 6.0		
Substructure height [m]		4.0		
Tower height [m]		31.0		
Hook height double reeving [m]		32.0		

WOLFFKRAN

Jib length	30 m – 80 m			
Item				
1	4.5 m	TV 20.4		
2	9.0 m	TV 20.4		
3	13.5 m	TV 20.4		
4	18.0 m	TV 20.4		
5	22.5 m	TV 20.4		
6	27.0 m	TV 20.4		
7	31.5 m	TV 20.4		
8	36.0 m	TV 20.4		
9	40.5 m	TV 20.4		
10	45.0 m	TV 20.4		
11	49.5 m	TVÜ 20.4		
12	54.0 m	UVA 25		
Substructure		KRE 480		
[m x m]		8.0 x 8.0		
Substructure height [m]		4.0		
Tower height [m]		58.0		
Hook height double reeving [m]		59.0		

3.5 Tower combinations on mobile cross frame (TV 20 connection)

Jib length	30 m – 80 m			
Item				
1	4.5 m	TV 20.4	TV 20.4	
2	9.0 m	TV 20.4	TV 20.4	
3	13.5 m	TV 20.4	TV 20.4	
4	18.0 m	TV 20.4	TV 20.4	
5	22.5 m	TV 20.4	TV 20.4	
6	27.0 m	TV 20.4	TV 20.4	
7	31.5 m	TV 20.4	TV 20.4	
8	36.0 m	TV 20.4	TV 20.4	
9	40.5 m	TV 20.4	TV 20.4	
10	45.0 m	TV 20.4	TV 20.4	
Substructure		KRF4 12-60/80	KRF6 12-60/80	
[m x m]		8.0 x 8.0	8.0 x 8.0	
Substructure height [m]		2.5	2.9	
Tower height [m]		47.5	47.9	
Hook height double reeving [m]		48.5	48.9	

Jib length	30 m – 80 m				
Item					
1	4.5 m	TV 20.4	TV 20.4		
2	9.0 m	TV 20.4	TV 20.4		
3	13.5 m	TV 20.4	TV 20.4		
4	18.0 m	TV 20.4	TV 20.4		
5	22.5 m	TV 20.4	TV 20.4		
6	27.0 m	TV 20.4	TV 20.4		
7	31.5 m	TV 20.4	TV 20.4		
8	36.0 m	TV 20.4	TV 20.4		
9	40.5 m	TV 20.4	TV 20.4		
10	41.5 m	VR 2023	VR 2023		
11	46.0 m	TV 23	TV 23		
12	50.5 m	TV 23	TV 23		
13	55.0 m	TV 23	TV 23		
Substructure		KRF4 12-60/80	KRF6 12-60/80		
[m x m]		8.0 x 8.0	8.0 x 8.0		
Substructure height [m]		2.5	2.9		
Tower height [m]		57.5	57.9		
Hook height double reeving [m]		58.5	58.9		

Jib length	30 m – 80 m			
Item				
1	4.5 m	TV 20.4		
2	9.0 m	TV 20.4		
3	13.5 m	TV 20.4		
4	18.0 m	TV 20.4		
5	22.5 m	TV 20.4		
6	27.0 m	TV 20.4		
7	31.5 m	TV 20.4		
8	36.0 m	TV 20.4		
9	40.5 m	TV 20.4		
10	41.5 m	VR 2023		
11	46.0 m	TV 23		
12	50.5 m	TV 23		
13	55.0 m	HTA 23		
14	59.5 m	HT 23		
15	64.0 m	HT 23		
Substructure		KRF6 12-60/80		
[m x m]		8.0 x 8.0		
Substructure height [m]		2.9		
Tower height [m]		66.9		
Hook height double reeving [m]		67.9		

Jib length	30 m – 80 m				
Item					
1	4.5 m	TV 20.4			
2	9.0 m	TV 20.4			
3	13.5 m	TV 20.4			
4	18.0 m	TV 20.4			
5	22.5 m	TV 20.4			
6	27.0 m	TV 20.4			
7	31.5 m	TV 20.4			
8	36.0 m	TV 20.4			
9	37.0 m	VR 2023			
10	41.5 m	TV 23			
11	46.0 m	TV 23			
12	50.5 m	HTA 23			
13	55.0 m	HT 23			
14	59.5 m	HT 23			
15	64.0 m	HT 23			
16	68.5 m	HT 23			
Substructure		KRF 16-80/100			
[m x m]		10.0 x 10.0			
Substructure height [m]		3.3			
Tower height [m]		71.8			
Hook height double reeving [m]		72.8			

WOLFFKRAN

Jib length	30 m – 80 m			
Item				
1	4.5 m	TV 20.4		
2	9.0 m	TV 20.4		
3	13.5 m	TV 20.4		
4	18.0 m	TV 20.4		
5	22.5 m	TV 20.4		
6	27.0 m	TV 20.4		
7	31.5 m	TV 20.4		
8	36.0 m	TV 20.4		
9	37.0 m	VR 2023		
10	41.5 m	TV 23		
11	46.0 m	TV 23		
12	50.5 m	HTA 23		
13	55.0 m	HT 23		
14	59.5 m	HT 23		
15	64.0 m	HT 23		
16	65.2 m	VR 23/25-29		
17	69.7 m	UV 29		
18	78.7 m	BT 29		
Substructure		KRF 16-80/100		
[m x m]		10.0 x 10.0		
Substructure height [m]		3.3		
Tower height [m]		83.0		
Hook height double reeving [m]		84.0		
Hook height quadruple reeving [m]		83.6		

3.6 Tower combinations on bogie truck (TV 20 - connection)

Jib length	30 m – 80 m				
Item					
1	4.5 m	TV 20.4			
2	9.0 m	TV 20.4			
3	13.5 m	TV 20.4			
4	18.0 m	TV 20.4			
5	22.5 m	TV 20.4			
Substructure		UW 260.3			
[m x m]		6.0 x 6.0			
Substructure height [m]		4.5			
Tower height [m]		27.0			
Hook height double reeving [m]		28.0			

WOLFFKRAN

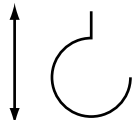
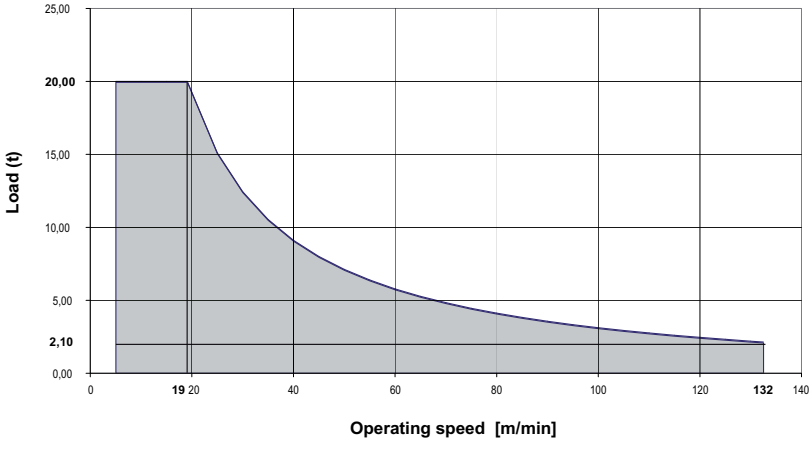

Jib length	30 m – 80 m			
Item				
1	4.5 m	TV 20.4		
2	9.0 m	TV 20.4		
3	13.5 m	TV 20.4		
4	18.0 m	TV 20.4		
5	22.5 m	TV 20.4		
6	27.0 m	TV 20.4		
7	31.5 m	TV 20.4		
8	36.0 m	TV 20.4		
9	40.5 m	TV 20.4		
10	45.0 m	TVÜ 20.4		
11	49.5 m	TV 25		
12	54.0 m	UVA 25		
Substructure		UW 480		
[m x m]		8.0 x 8.0		
Substructure height [m]		5.0		
Tower height [m]		59.0		
Hook height double reeving [m]		60.0		

4 Operating speeds

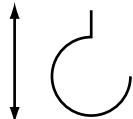
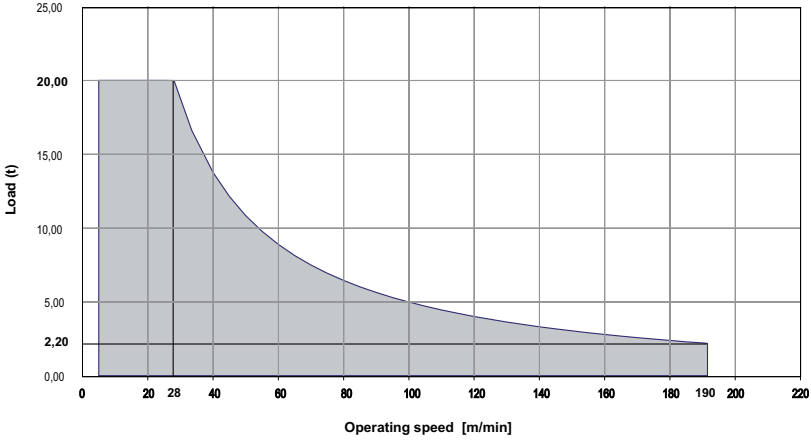
Drive unit [type]	Operating speed Carrying load		Hook travel distance max. [m]	Power [kW]	Total connected load [kVA]
Hw2075FU	Lifting / lowering		400	75	98.0 Total connected load at coincidence factor of 0.7
					



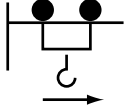
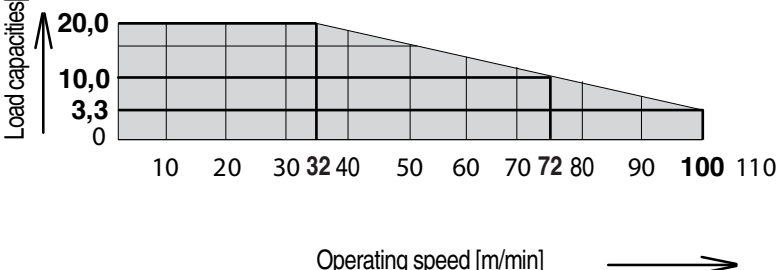

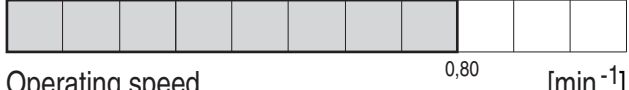



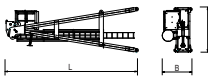
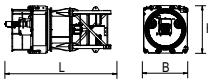
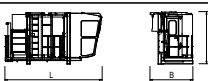
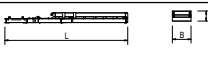
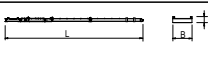
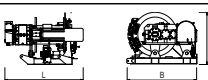
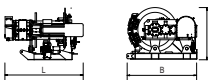
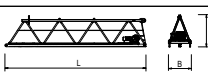

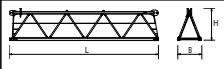
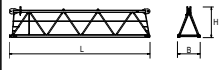
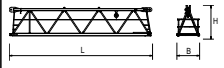
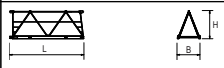

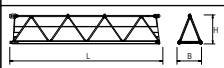
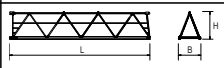
Drive unit [type]	Operating speed Carrying load		Hook travel distance max. [m]	Power [kW]	Total connected load [kVA]
Hw20110FU	Lifting / lowering		400	110	125.0 Total connected load at coincidence factor of 0.7
					

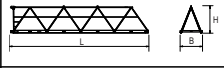
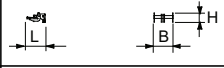
WOLFFKRAN

<p>KW</p> 	<p>Crab movement</p>	<p>9.0</p>		
				
<p>SG</p> 	<p>Slewing</p>	<p>2 x 7.5</p>		
				

5 Package list 8033.20

Quantity	Description	Package	L [m]	W [m]	H [m]	Weight [kg]	Volume [m³]		
1	Tower head section, complete with slewing frame, ball slew bearing, slewing gear and slip ring system (stay parts on counter jib)		with UV 20 lower part of tower head section					15000 (410)	66.41
			11.55	2.30	2.50				
			with HT 23 lower part of tower head section					16300 (410)	76.34
			11.75	2.32	2.80				
	Tower head section upper part (stay parts for counter jib)		7.39	2.49	1.66	2925 (410)	30.55		
			Tower head section lower part with slewing frame, ball slew bearing, slewing gear and slip ring system		with UV 20 lower part of tower head section				
	5.60	2.30			2.50				
	with HT 23 lower part of tower head section					13370 (410)	37.68		
5.80	2.32	2.80							
1	Driver's cab with driver's cab suspension		4.82	2.19	2.55	2625	26.92		
1	Counter jib in hinged position (stay parts on counter jib)		11.98	2.30	1.31	7140 (865)	36.10		
	Counter jib (stay parts on counter jib)		22.24	2.30	0.72	7140 (865)	36.83		
1	Hoist winch platform Hw21110FU without hoisting rope (2. Brake) (210 m hoisting rope)		2.58	2.31	1.70	4930 (680) (600)	10.13		
	Hoist winch platform Hw2075FU without hoisting rope (2. Brake) (210 m hoisting rope)		2.58	2.31	1.70	4880 (680) (600)	10.13		
1	Jib section 1 with traverse gear		10.19	1.64	2.29	3400	38.54		

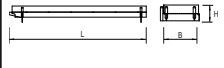
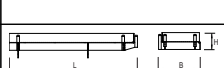
Quantity	Description	Package	L [m]	W [m]	H [m]	Weight [kg]	Volume [m ³]
1	Jib section 2		10.19	1.64	2.08	24-60	34.76
1	Jib section 3		10.23	1.64	2.08	23-20	34.90
1	Jib section 4		10.30	1.64	2.07	23-00	34.97
1	Jib section 5		5.33	1.64	2.03	11-35	17.74
1	Jib section 6		2.83	1.64	2.03	695	9.42
1	Jib section 7		10.28	1.64	2.03	18-15	34.22
1	Jib section 8		10.22	1.64	2.02	12-90	33.86
1	Jib section 9		5.20	1.64	2.01	660	17.14
1	Jib section 10		10.19	1.64	2.01	10-40	33.59
1	Rope swivel crossbeam		1.38	1.54	0.50	245	1.06
1	Trolley LK 20		2.00	1.88	1.33	600	5.00
1	Maintenance cage		0.75	0.55	1.69	55	0.70
1	Snatch block U 20		0.72	0.29	1.84	750	0.38
1	Brace rods for operating radius 80 m		10.17	0.25	0.60	27-80	1.53
1	Auxiliary crane (stand)		2.53	0.30	2.96	220 (8-0)	2.25
1	Insert platform under hoisting winch platform		1.93	1.88	0.24	100	0.87
1	Package pedestal 1 on counterjib 8033		2.73	0.66	0.33	100	0.59
2	Platform 2/3 on counter jib		1.72	0.66	0.33	75	0.37
1	Package pedestal 4 on counterjib 8033		2.89	0.66	0.33	105	0.63
1	Package pedestal 5 on counterjib 8033		2.77	0.66	0.33	100	0.60

WOLFFKRAN

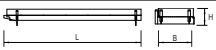
Quantity	Description	Package	L [m]	W [m]	H [m]	Weight [kg]	Volume [m³]
1	Package pedestal 6 on counterjib 8033		2.61	0.66	0.33	95	0.57

NOTICE! Bracketed weights must be added to their associated components.

6 Assembly weights

6.1 Counterweight blocks



NOTICE

The described diagrams of the counterweights and central ballast blocks only show sketches. Have them issue the reinforcement charts by experts.

6.1.1 Counterweight block, 2.7 t

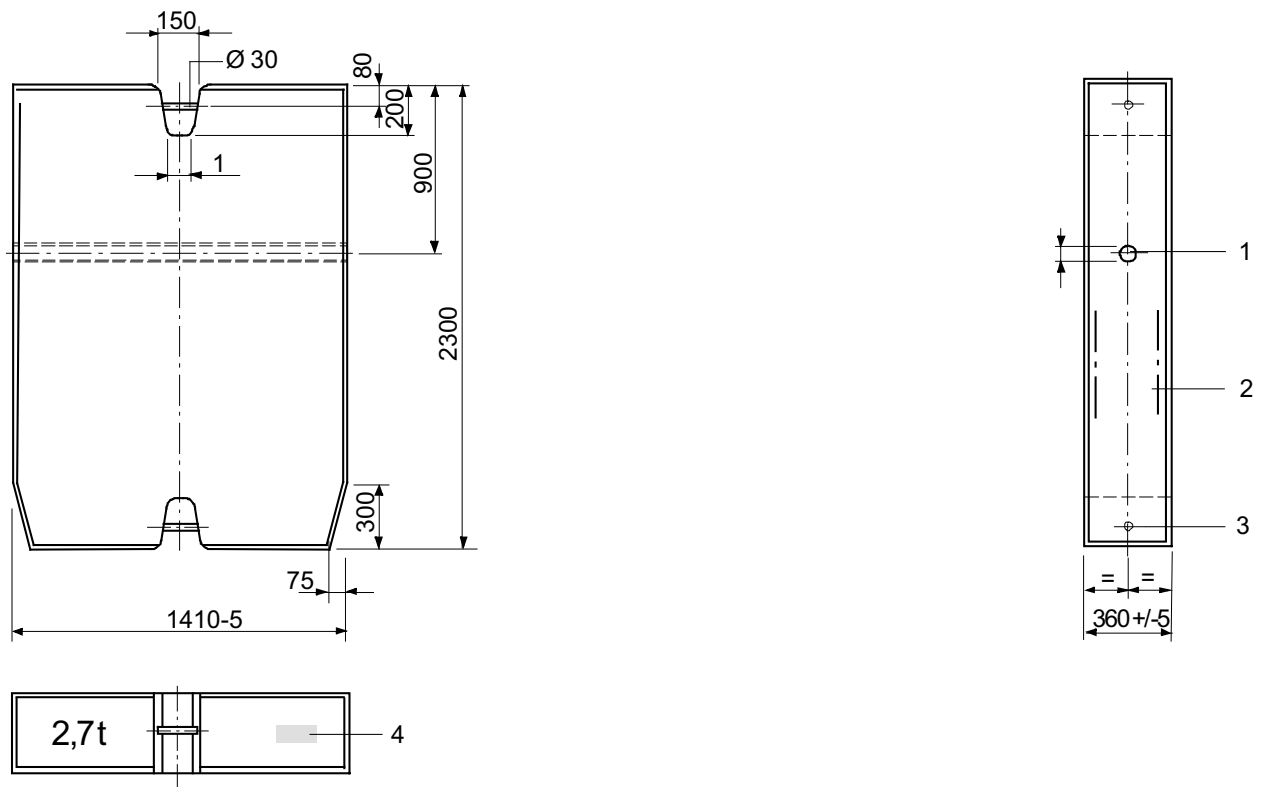

Data counterweight block 2.7 t

Item	Data
Material	Concrete, min. C 20/25
Max. permitted weight tolerance	+/- 3 %
Order number	962-2-005966
1	Connection for stub shaft (\varnothing 40/ 78 x 215 962-4-006490)
2	Structural steel reinforcement
3	Suspension
4	Component identifier

6.2 Total weight jib assembly

Trolley jib, complete: Trolley, trolley ropes, snatch block, standard railings and rope swivel crossbeam

Jib length [m]	Weight [kg] WOLFF 8033.20cross
80.0	20905
77.5	20940
75.0	20245
72.5	19805
70.0	19110
67.5	19900
65.0	19205
62.5	18765
60.0	18070
57.5	18610
55.0	16265
52.5	15825
50.0	15130
47.5	15670
45.0	14975
42.5	14535
40.0	13840
37.5	13855
35.0	13160
32.5	12720
30.0	12025

6.3 Assembly weight slewing gear

Module	Crane parts	Weight [kg]	
Tower head section, complete – tower connection TV 20 tower top lower part			15410
	▪ Tower head section upper part including brace plates	3335	
	▪ Tower head section lower part including slewing frame, ball race bearing, slewing gears, standard railings and slip ring system	12075	
Tower head section, complete – tower connection HT 23 tower top lower part			16710
	▪ Tower head section upper part including brace plates	3335	
	▪ Tower head section lower part including slewing frame, ball race bearing, slewing gears, standard railings and slip ring system	13375	
Operator cabinet platform, complete			2625
	▪ Operator cabin with operator cabin platform	2625	
Counter jib with Hw20110FU, complete			14840
	▪ Counter jib with brace plates and standard railings	8910	
	▪ Hoist winch platform Hw20110FU (incl. 210 m hoisting rope)	5530	
	▪ Pedestal under hoisting winch platform	100	
	▪ Auxiliary crane incl. stand	300	
Counter jib with Hw2075FU, complete			14790
	▪ Counter jib with brace plates and standard railings	8910	
	▪ Hoist winch platform Hw2075FU (incl. 210 m hoisting rope)	5480	
	▪ Pedestal under hoisting winch platform	100	
	▪ Auxiliary crane incl. stand	300	

6.4 Assembly weight cross frame

Module	crane part	Weight [kg]	
Cross frame KR 12 - 60 (without accessories)			14271
(6 m x 6 m)	▪ 4 bolted spigots AZ 140 M	788	
	▪ 4 bolted spigots AZ 140 E 10	788	
	▪ 4 bolted spigots AZ 156 M	844	
	▪ 4 bolted spigots AZ 140 E 17	875	
	▪ 4 bolted spigots AZ 160 HT23	668	
Cross frame KR 12 – 60/80 (without accessories)			17732
(8 m x 8 m)	▪ 4 bolted spigots AZ 140 M	788	
	▪ 4 bolted spigots AZ 140 E 10	788	
	▪ 4 bolted spigots AZ 156 M	844	
	▪ 4 bolted spigots AZ 140 E 17	875	
	▪ 4 bolted spigots AZ 160 HT23	668	
Cross frame KR 16 - 80 (without accessories)			21450
(8 m x 8 m)	▪ 4 bolted spigots AZ 140 E KR 16 – 80	620	
	▪ 4 bolted spigots AZ 156 M KR 16 – 80	680	
	▪ 4 bolted spigots AZ 156S M KR 16 - 80	675	
Cross frame KR 16 - 80/ 100 (without accessories)			25400
(10 m x 10 m)	▪ 4 bolted spigots AZ 140 E KR 16 – 80	620	
	▪ 4 bolted spigots AZ 156 M KR 16 – 80	680	
	▪ 4 bolted spigots AZ 156S M KR 16 - 80	675	

6.5 Assembly weight cross frame elements

Module	Crane parts	Weight [kg]	
	Cross frame element KRE 260.2, complete		10 900
	▪ Cross frame platform with hinged section, corner plates and transport locks	5 455	
	▪ Mast base with diagonal struts and tie rods	5 445	
	Cross frame element KRE 480 complete		24 250
	▪ Mast base	7 100	
	▪ Hinged sections with corner plates	6 250	
	▪ Diagonal struts and ballast carrier	9 260	
	▪ Assembly platform, ladder, and small parts	1 640	

6.6 Assembly weight bogie truck

Module	Crane parts	Weight [kg]	
Bogie truck UW 260.3, complete			17 200
	▪ Bogie truck platform with hinged sections, subframes and transport locks	11 300	
	▪ Mast base with diagonal struts and tie rods	5 900	
Bogie truck UW 480, complete			34 000
	▪ Mast base	7 100	
	▪ Hinged sections with lifting beam and subframes	16 000	
	▪ Diagonal struts and ballast carrier	9 260	
	▪ Assembly platform, ladder, and small parts	1 640	

6.7 Assembly weights travelling cross frame

Module	crane part	Weight [kg]	
Cross frame KRF 12 – 60/80 complete (8.0m x 8.0m)			42 480
	▪ Cross frame (without subframe and accessories)	19 260	
	▪ Extension member	720	
	▪ Backing braces	1 980	
	▪ Control cabinet	100	
	▪ Rope drum with mounting	600	
	▪ small items	240	
	▪ Drive gear	19 580	
	▪ 4 bolted spigots AZ 140 M	788	
	▪ 4 bolted spigots AZ 140 E 10	788	
	▪ 4 bolted spigots AZ 156 M	844	
	▪ 4 bolted spigots AZ 140 E 17	875	
	▪ 4 bolted spigots AZ 160 HT23	668	

6.8 Hook height above ground required for mobile cranes

For information about the height of the WOLFF slewing tower crane, refer to Tower combinations [4].

NOTICE! During assembly, allowances must be made for level differences (mobile crane to base of the slewing tower crane).

Hook height above ground required for mobile cranes (X) = height of the WOLFF slewing tower crane (A) + clearance of 15 (B).

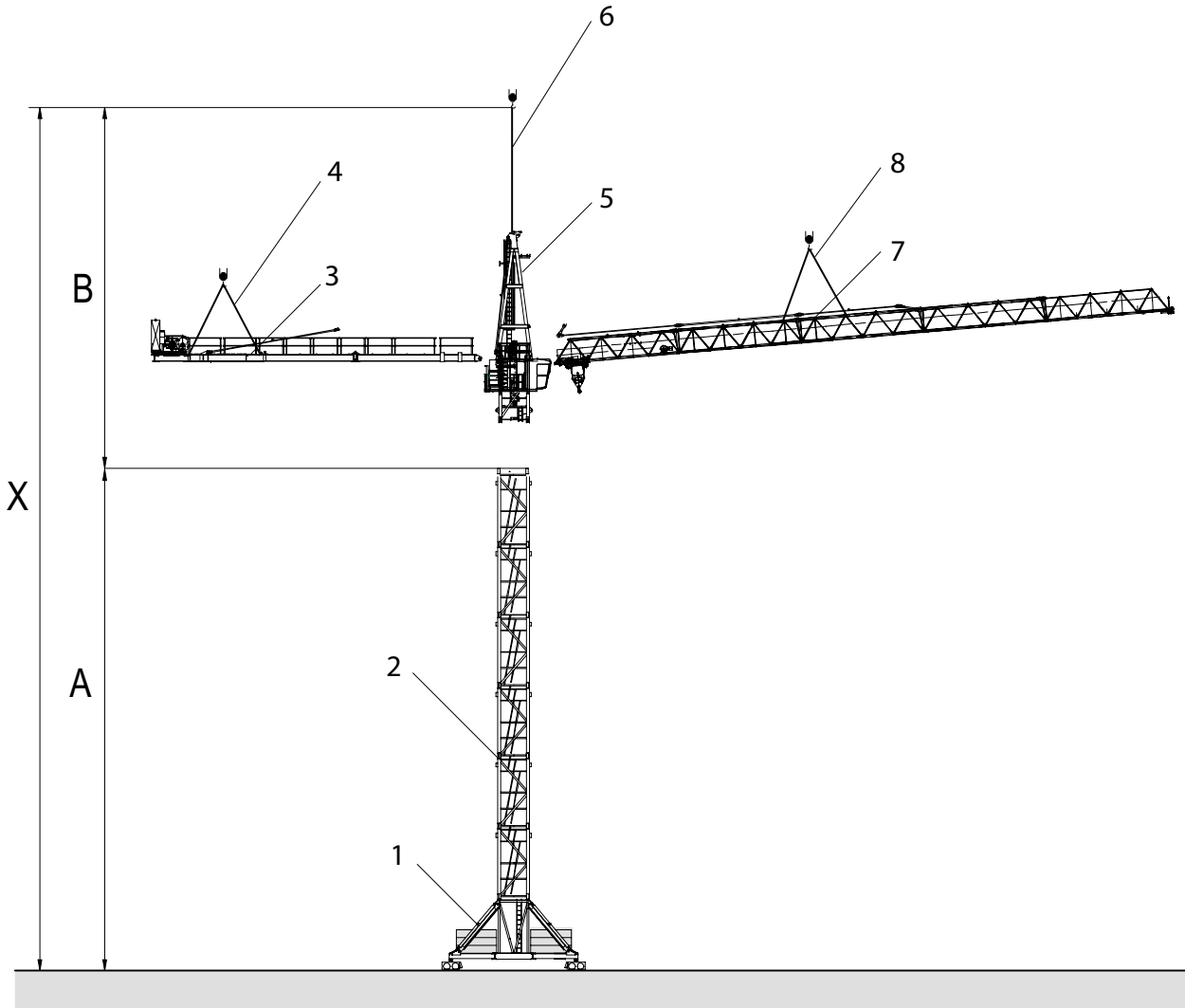

Exemplary illustration

[A]	Height of the WOLFF slewing tower crane	[B]	Clearance 15 m
[X]	Hook height above ground required for the mobile crane		
1	Substructure	5	Tower head section, complete
2	Tower element	6	Single-point lifting tackle (1 m with shackle)
3	Counter jib including hoisting winch platform	7	Jib, complete
4	Four-point lifting tackle (6 m with shackle)	8	Four-point lifting tackle (6 m with shackle)

See also:

- Tower combinations [\[4\]](#)

7 Assembly diagrams

7.1 Jib attachment diagram

	NOTICE
	For jib assembly, use a Four-point lifting tackle (6 m with shackle).

Length of jib elements

Item	Length [m]
Jib element 1, 2, 3, 4, 7, 8, 10	10
Jib section 5.9	5
Jib section 6	2.5

7.1.1 Trolley jib - attachment diagram 80.0 m to 75.0 m

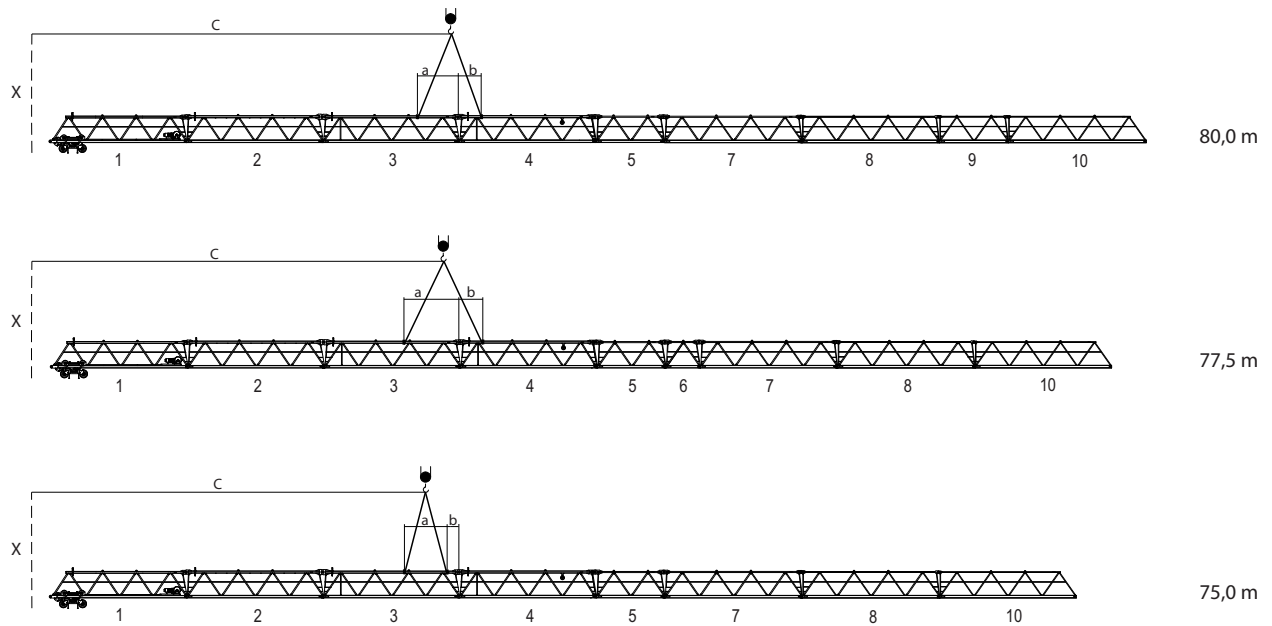

a	Dimension a	b	Dimension b
c	Dimension c	X	Middle of tower

Attachment data 8033.20

Data	Jib length [m]		
	80.0	77.5	75.0
a [m]	2.94	3.91	3.02
b [m]	1.61	1.61	0.89
c [m]	30.50	30.00	28.80
Weight [kg]	20905	20940	20245

7.1.2 Trolley jib - attachment diagram 72.5 m to 67.5 m

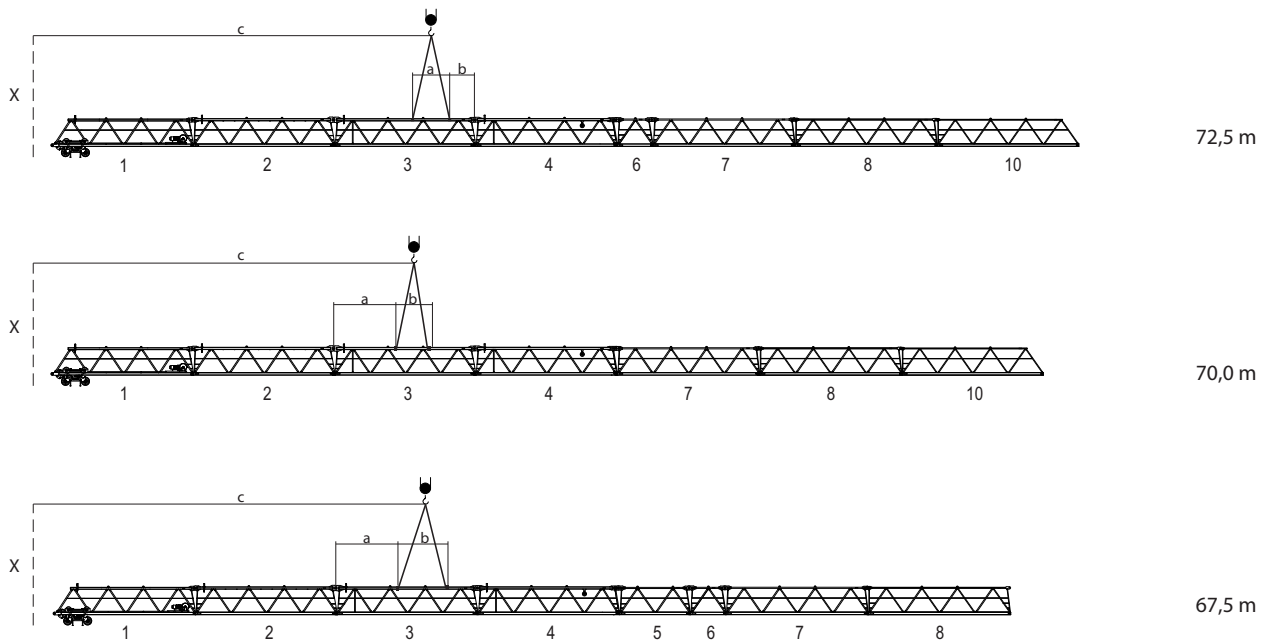

a	Dimension a	b	Dimension b
c	Dimension c	X	Middle of tower

Attachment data 8033.20

Data	Jib length [m]		
	72.5	70.0	67.5
a [m]	2.79	4.56	4.56
b [m]	1.85	2.06	3.59
c [m]	27.90	26.70	27.50
Weight [kg]	19805	19110	19900

7.1.3 Trolley jib - attachment diagram 65.0 m to 60.0 m

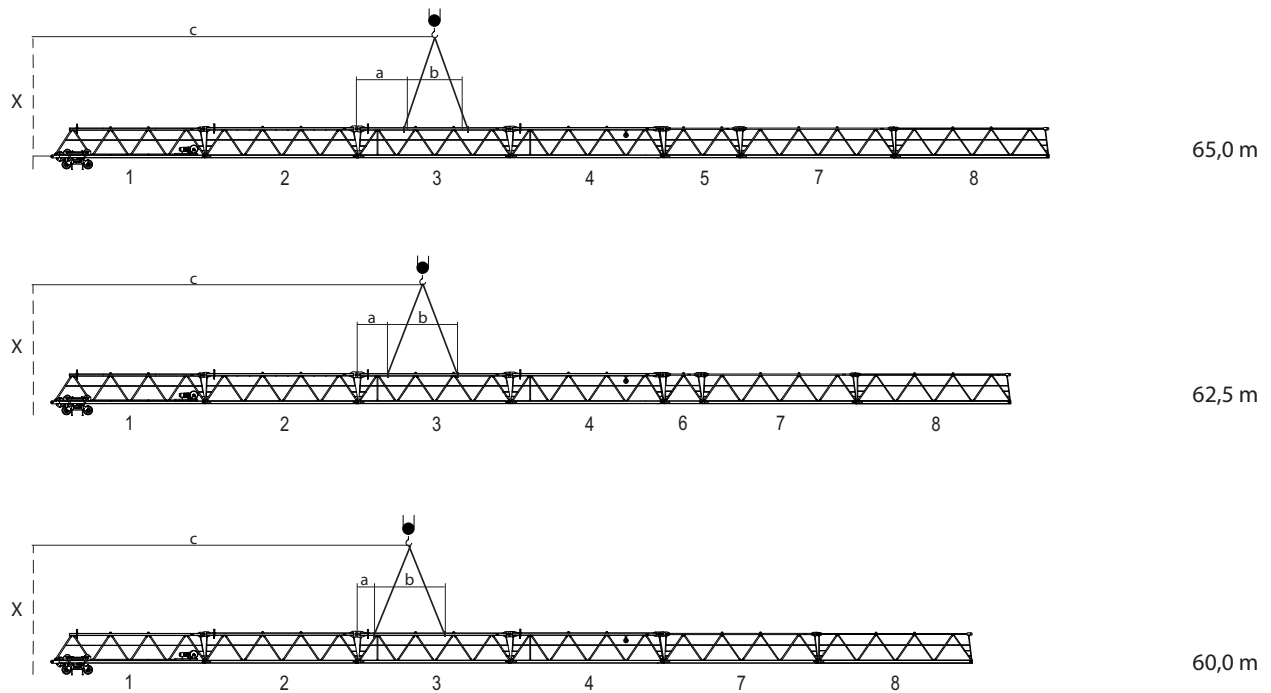

a	Dimension a	b	Dimension b
c	Dimension c	X	Middle of tower

Attachment data 8033.20

Data	Jib length [m]		
	65.0	62.5	60.0
a [m]	2.86	2.06	1.09
b [m]	4.49	4.56	4.56
c [m]	26.30	25.50	24.50
Weight [kg]	19205	18765	18070

7.1.4 Trolley jib - attachment diagram 57.5 m to 52.5 m

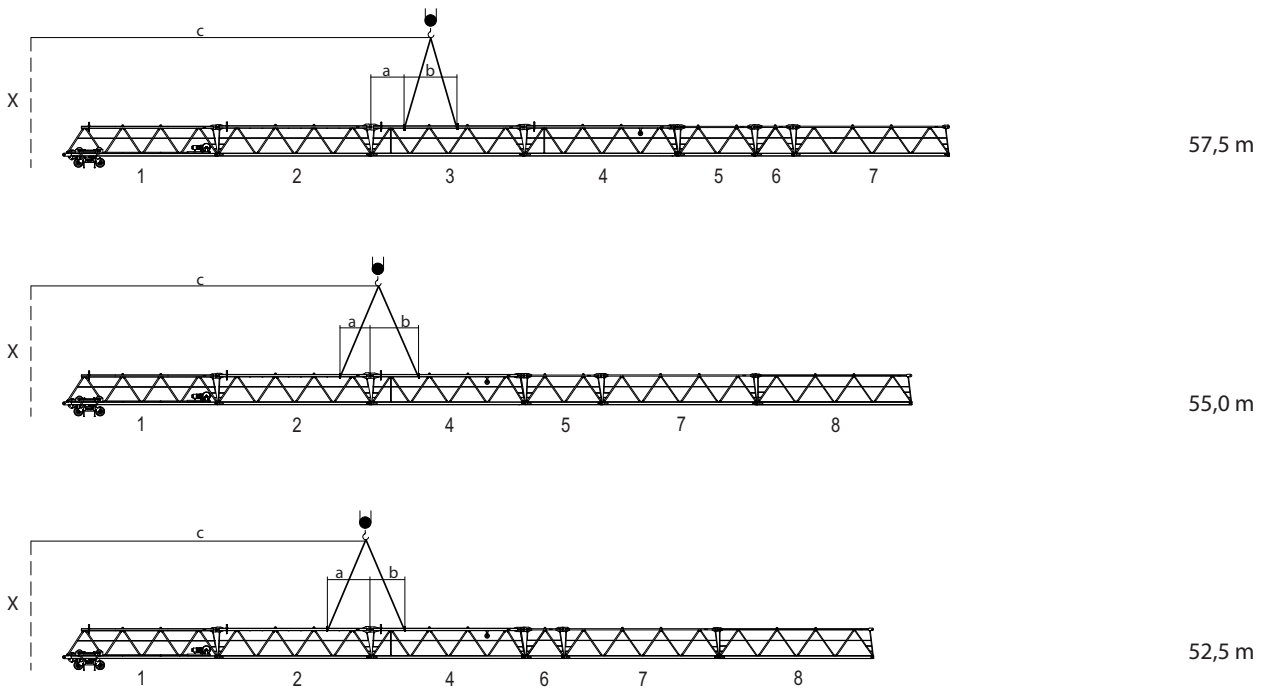

a	Dimension a	b	Dimension b
c	Dimension c	X	Middle of tower

Attachment data 8033.20

Data	Jib length [m]		
	57.5	55.0	52.5
a [m]	2.06	2.14	2.94
b [m]	3.59	3.15	2.35
c [m]	25.00	21.70	20.90
Weight [kg]	18610	16265	15825

7.1.5 Trolley jib - attachment diagram 50.0 m to 45.0 m

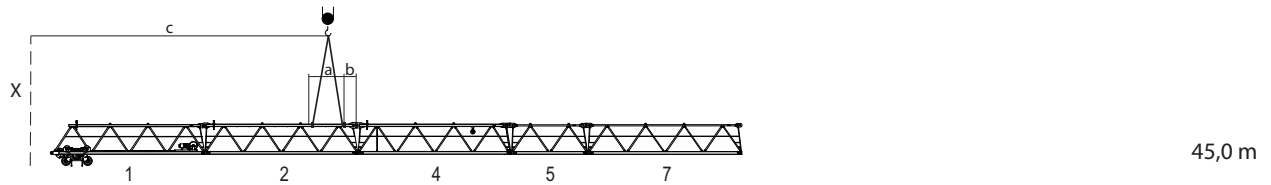
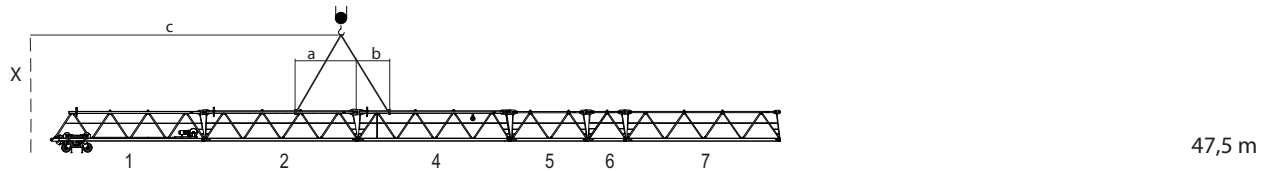
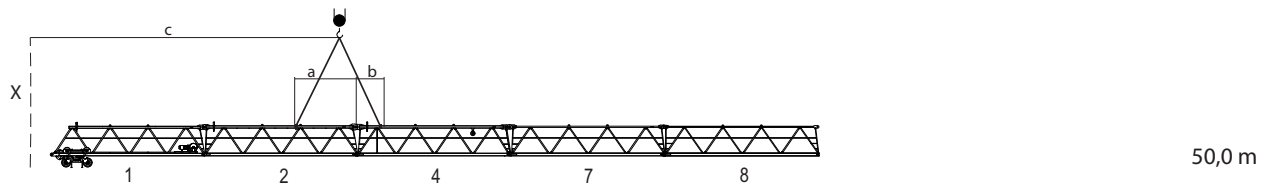

a	Dimension a	b	Dimension b
c	Dimension c	X	Middle of tower

Attachment data 8033.20

Data	Jib length [m]		
	50.0	47.5	45.0
a [m]	3.92	3.92	2.06
b [m]	1.61	2.35	0.89
c [m]	20.00	20.40	19.20
Weight [kg]	15130	15670	14975

7.1.6 Trolley jib - attachment diagram 42.5 m to 37.5 m

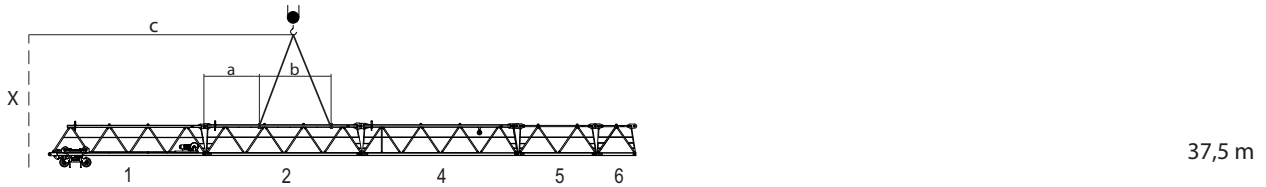
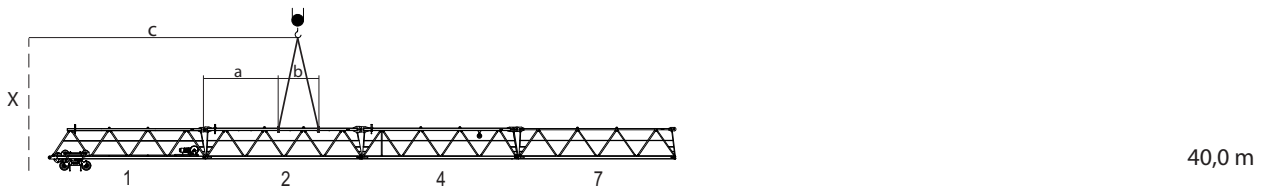
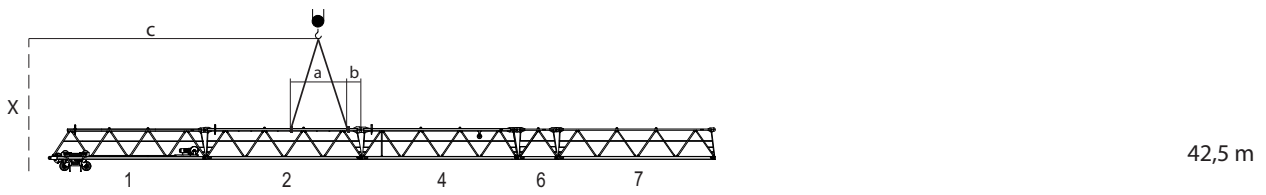

a	Dimension a	b	Dimension b
c	Dimension c	X	Middle of tower

Attachment data 8033.20

Data	Jib length [m]		
	42.5	40.0	37.5
a [m]	3.76	4.56	3.58
b [m]	0.89	2.79	4.57
c [m]	18.40	17.10	17.00
Weight [kg]	14535	13840	13855

7.1.7 Trolley jib - attachment diagram 35.0 m to 30.0 m

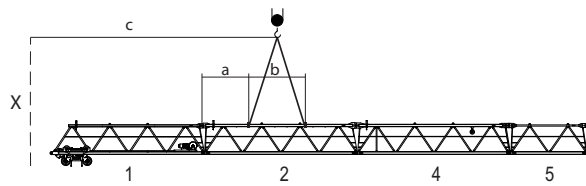

35,0 m

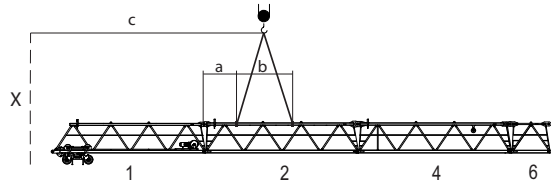

32,5 m

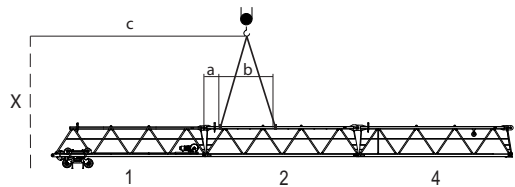

30,0 m

a	Dimension a	b	Dimension b
c	Dimension c	X	Middle of tower

Attachment data 8033.20

Data	Jib length [m]		
	35.0	32.5	30.0
a [m]	2.86	2.06	1.08
b [m]	3.76	3.59	3.77
c [m]	15.90	15.00	14.10
Weight [kg]	13160	12720	12025

7.2 Jib brace diagram

double bracing
counterjib

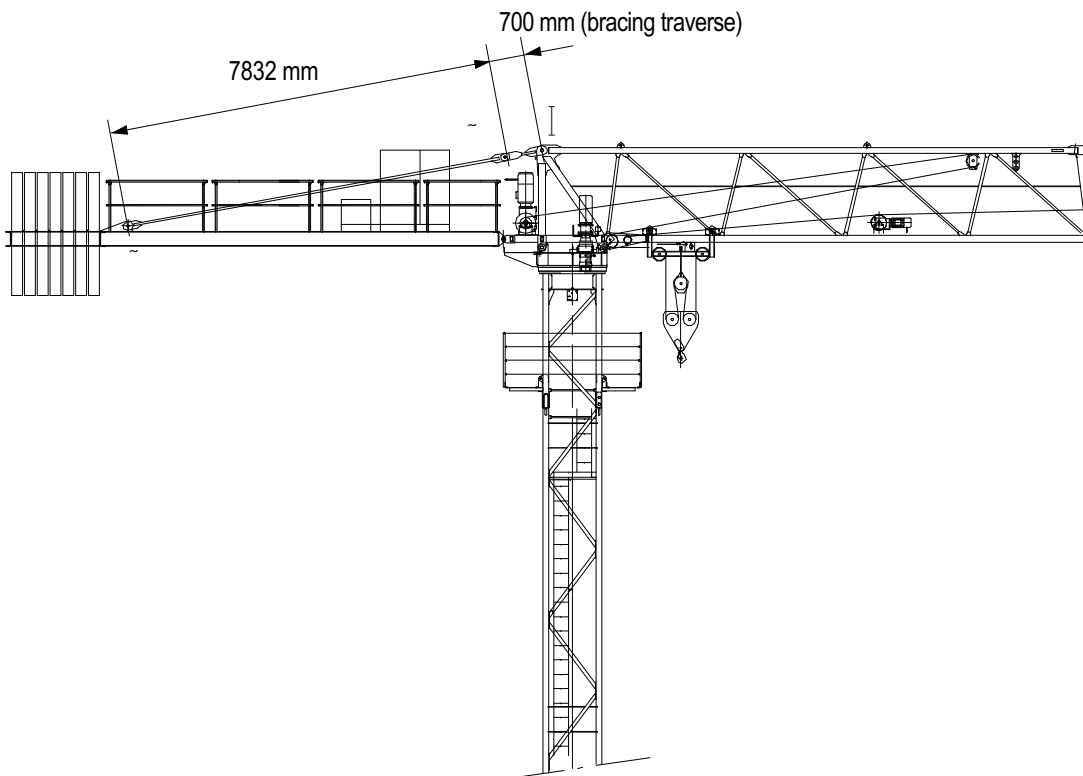

Bolt table

Jib length	Item	Bolts		Fuse	
		Quant-ity	Dimension [mm]	Quant-ity	Dimension [mm]
Jibs - all	-	-	-	-	-
Counter jib	a	4	Ø 60/50x130	4	Spring retainers 6/50, galvanized, yellow
	b	1	Ø 70/60x165	1	Spring retainers 10/60-80, galvanized, yellow

WOLFFKRAN

double bracing
counterjib

simple bracing
trolley jib

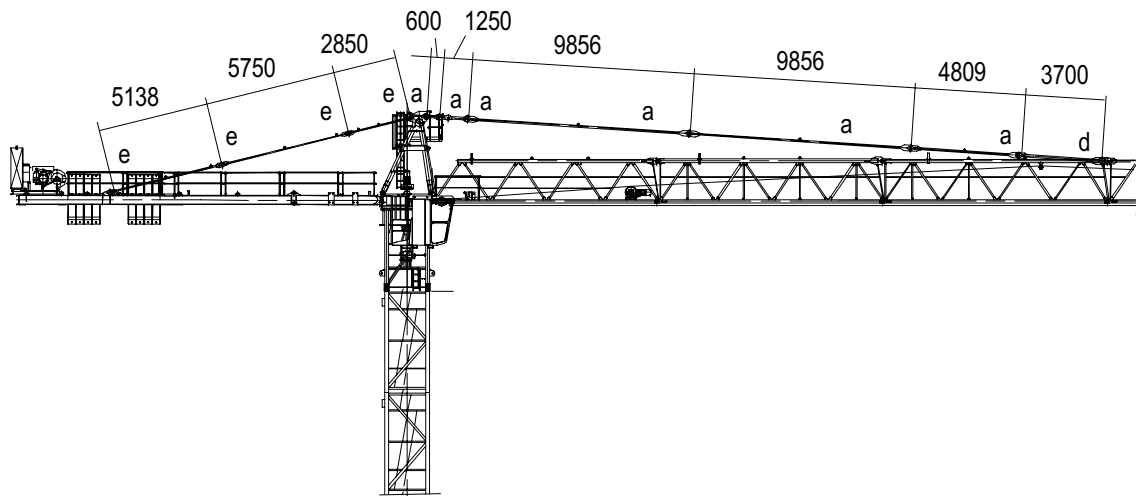

Bolt table

Jib length	Item	Bolts		Fuse	
		Quantity	Dimension [mm]	Quantity	Dimension [mm]
Jibs - all	a	6	Ø 100/90x225	6	Spring retainers Ø10/60-80, steel galvanized, yellow
	d	1	Ø 100/90x300	1	Axle retainer 40x10x140
				2	Hex. screws M16x30 DIN 933-8.8 galv.
				2	Lock washer A 16 DIN 127 Fed.steel, galvanized
Counter jib	e	8	Ø 70/60x150mm	8	Spring retainers Ø10/60-80, steel galvanized, yellow

Jib brace diagram 60m – 50m

single bracing

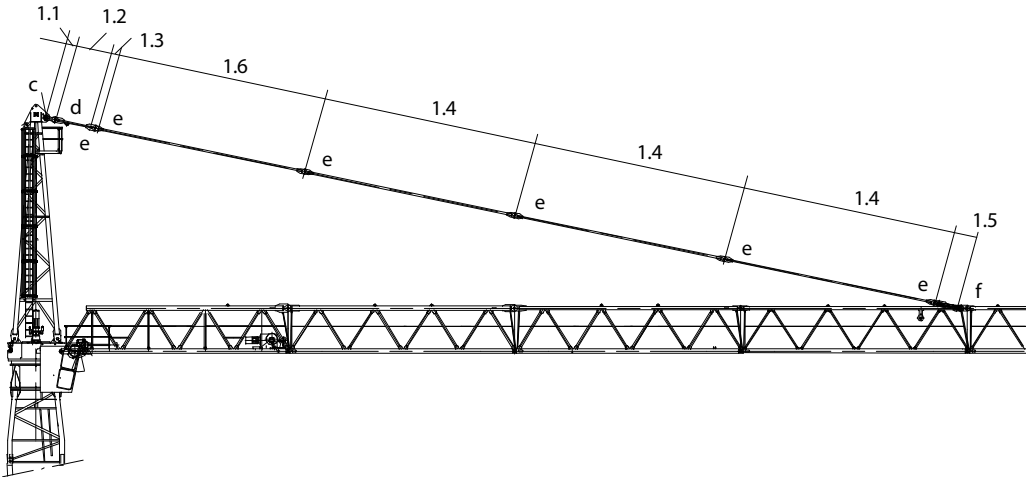

Brace table

Brace	Hole pitch [mm]						Brace types
	Brace 1.1	Brace 1.2	Brace 1.3	Brace 1.4	Brace 1.5	Brace 1.6	
Jib	400	1805	320	9190	1400	9724	single

Bolt table

Jib length	Brace		Bolts			Fuse	
	No.	Quantity	Ref.	Quantity	Dimension [mm]	Quantity	Dimension [mm]
Jib 60m – 50m		1	c	1	Ø 120/100x310	1	Axle retainer 40x10x140
	1.1	1	d	1	Ø 100/80x240	1	Axle retainer 40x10x140
	1.2	1	e	1	Ø 90/80x200	1	Spring retainers 10/ 60-80
	1.3	1	-	-	-	-	-
	1.4	3	e	3	Ø 90/80x200	3	Spring retainers 10/ 60-80
			f	1	Ø 90/80x310	1	Axle retainer 40x10x140
	1.6	1	e	1	Ø 90/80x200	1	Spring retainers 10/ 60-80

Jib brace diagram 45m – 30m

single bracing

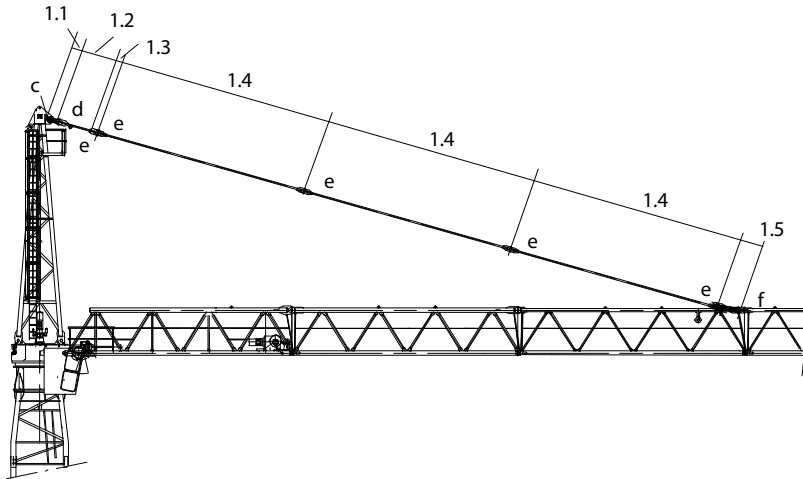

Brace table

Brace	Hole pitch [mm]						Brace types
	Brace 1.1	Brace 1.2	Brace 1.3	Brace 1.4	Brace 1.5	Brace 1.6	
Jib	400	1805	320	9190	1400	9724	single

Bolt table

Jib length	Brace		Bolts			Fuse	
	No.	Quantity	Ref.	Quantity	Dimension [mm]	Quantity	Dimension [mm]
Jib 45m – 30m		1	c	1	Ø 120/100x310	1	Axle retainer 40x10x140
	1.1	1	d	1	Ø 100/80x240	1	Axle retainer 40x10x140
	1.2	1	e	1	Ø 90/80x200	1	Spring retainers 10/ 60-80
	1.3	1	-	-	-	-	-
	1.4	3	e	3	Ø 90/80x200	3	Spring retainers 10/ 60-80
			e	1	Ø 90/80x200	1	Spring retainers 10/ 60-80
1.5	1	f	1	Ø 90/80x310	1	Axle retainer 40x10x140	

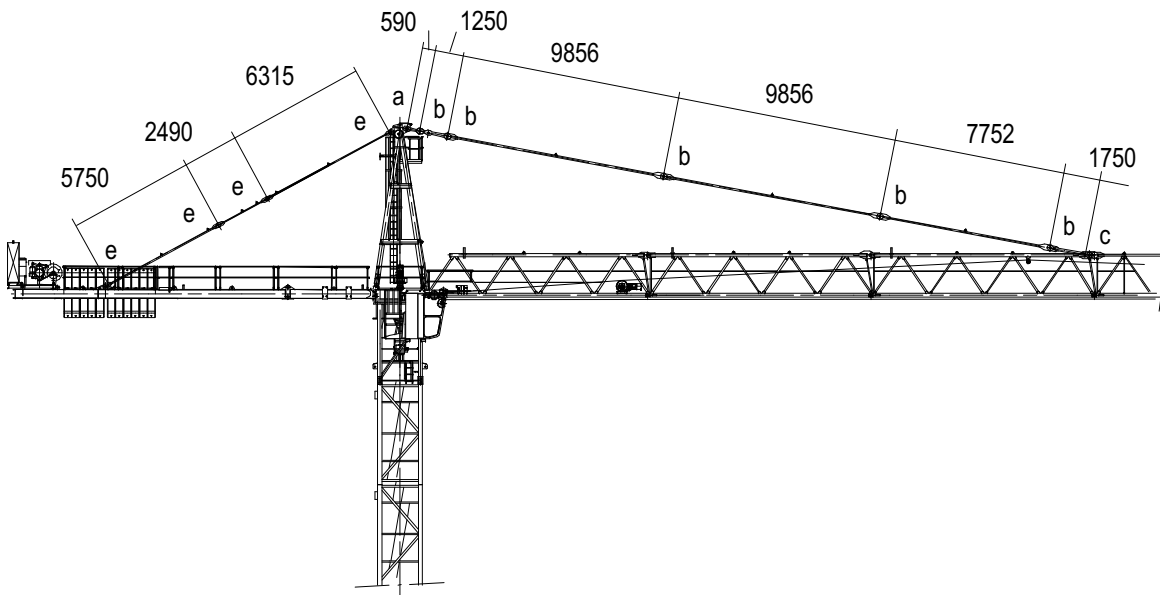

Bolt table

Jib length	Item	Bolts		Fuse	
		Quantity	Dimension [mm]	Quantity	Dimension [mm]
Jibs - all	a	1	Ø 100/90x225	1	Spring retainers Ø10/60-80, steel galvanized, yellow
	b	5	Ø 80/70x180	5	Spring retainers Ø10/60-80, steel galvanized, yellow
	c	1	Ø 80/70x272	1	Axle retainer 40x10x140
2				Hex. screws M16x30 DIN 933-8.8 galv.	
2				Lock washer A 16 DIN 127 Fed.steel, galvanized	
Counter jib	e	8	Ø 70/60x150mm	8	Spring retainers Ø10/60-80, steel galvanized, yellow

Jib brace diagram 75m – 60m

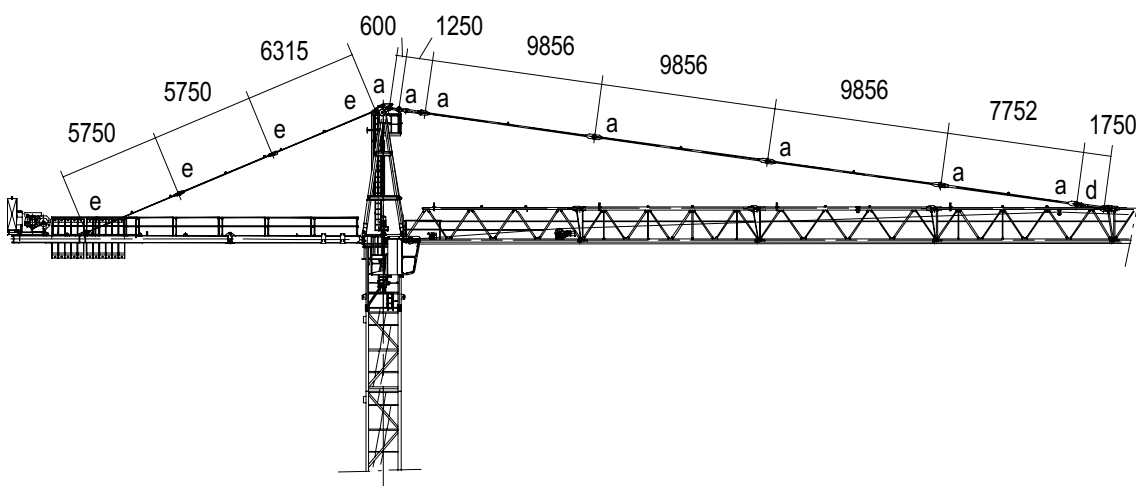

Bolt table

Jib length	Item	Bolts		Fuse	
		Quantity	Dimension [mm]	Quantity	Dimension [mm]
Jib 75m – 60m	a	7	Ø 100/90x225	7	Spring retainers Ø10/60-80, steel galvanized, yellow
	d	1	Ø 100/90x300	1	Axle retainer 40x10x140
				2	Hex. screws M16x30 DIN 933-8.8 galv.
				2	Lock washer A 16 DIN 127 Fed.steel, galvanized
Counter jib	e	8	Ø 70/60x150mm	8	Spring retainers Ø10/60-80, steel galvanized, yellow

Jib brace diagram 55m – 30m

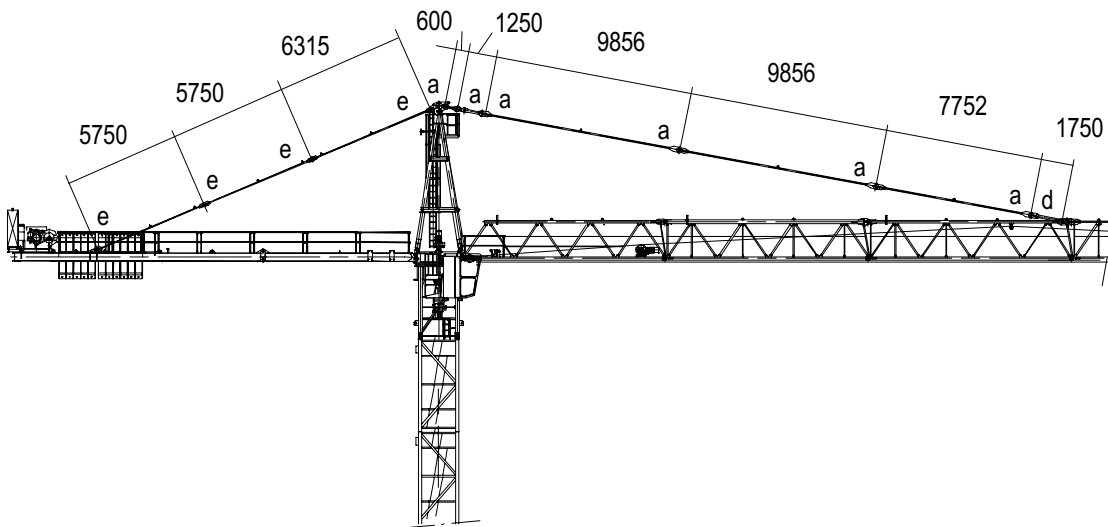

Bolt table

Jib length	Item	Bolts		Fuse	
		Quantity	Dimension [mm]	Quantity	Dimension [mm]
Jib 55m – 30m	a	6	Ø 100/90x225	6	Spring retainers Ø10/60-80, steel galvanized, yellow
	d	1	Ø 100/90x300	1	Axle retainer 40x10x140
				2	Hex. screws M16x30 DIN 933-8.8 galv.
				2	Lock washer A 16 DIN 127 Fed.steel, galvanized
Counter jib	e	8	Ø 70/60x150mm	8	Spring retainers Ø10/60-80, steel galvanized, yellow

Brace diagram for jib 80m

single bracing

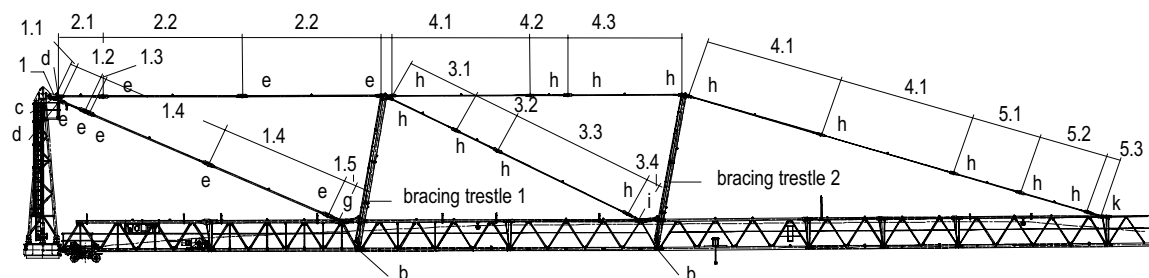

Bolt table

Brace			Ref.	Bolts		Fuse	
Ref.	Quantity	Hole pitch [mm]		Quantity	Dimension [mm]	Quantity	Dimension [mm]
1	1		c	1	Ø 120/100x310	1	Axle retainer 40x10x140

Brace			Ref.	Bolts		Fuse	
Ref.	Quantity	Hole pitch [mm]		Quantity	Dimension [mm]	Quantity	Dimension [mm]
1	1	307	d	1	Ø 100/80x240	1	Axle retainer 40x10x140
		560	d	1	Ø 100/80x240	1	Axle retainer 40x10x140
1.1	1	400	e	1	Ø 90/80x200	1	Spring retainers 10/60-80
1.2	1	1805	e	1	Ø 90/80x200	1	Spring retainers 10/60-80
1.3	1	320	e	1	Ø 90/80x200	1	Spring retainers 10/60-80
1.4	2	8700	e	2	Ø 90/80x200	2	Spring retainers 10/60-80
1.5	1	1000	g	1	Ø 90/80x330	1	Axle retainer 40x10x140
2.1	1	2983	e	1	Ø 90/80x200	1	Spring retainers 10/60-80
2.2	2	9300	e	2	Ø 90/80x200	2	Spring retainers 10/60-80
3.1	1	5000	h	1	Ø 70/60x167	1	Locking pin 12x75
3.2	1	3100	h	1	Ø 70/60x167	1	Locking pin 12x75
3.3	1	9662	h	1	Ø 70/60x167	1	Locking pin 12x75
3.4	1	1000	h	1	Ø 70/60x167	1	Locking pin 12x75
			i	1	Ø 70/60x275	1	Axle retainer 30x8x100
4.1	3	9253	h	3	Ø 70/60x167	3	Locking pin 12x75
4.2	1	2500	h	1	Ø 70/60x167	1	Locking pin 12x75
4.3	1	7634	h	2	Ø 70/60x167	2	Locking pin 12x75
5.1	1	4619	h	1	Ø 70/60x167	1	Locking pin 12x75
5.2	1	4745	h	1	Ø 70/60x167	1	Locking pin 12x75
5.3	1	1000	h	1	Ø 70/60x167	1	Locking pin 12x75
			k	1	Ø 70/60x255	1	Axle retainer 30x8x100
Bracing block 1 and 2			b	4	Ø 65/55x125	4	Locking pin 12x75

Jib brace diagram 75m - 70m

single bracing

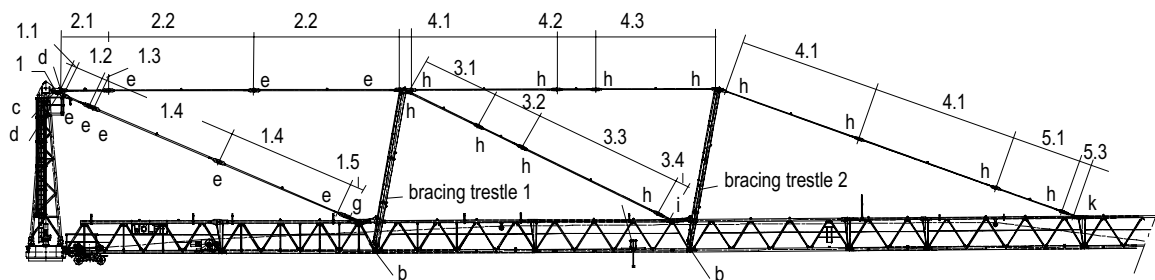

Bolt table

Brace			Ref.	Bolts		Fuse	
Ref.	Quantity	Hole pitch [mm]		Quantity	Dimension [mm]	Quantity	Dimension [mm]
1	1		c	1	Ø 120/100x310	1	Axle retainer 40x10x140
		307	d	1	Ø 100/80x240	1	Axle retainer 40x10x140
		560	d	1	Ø 100/80x240	1	Axle retainer 40x10x140
1.1	1	400	e	1	Ø 90/80x200	1	Spring retainers 10/60-80
1.2	1	1805	e	1	Ø 90/80x200	1	Spring retainers 10/60-80
1.3	1	320	e	1	Ø 90/80x200	1	Spring retainers 10/60-80
1.4	2	8700	e	2	Ø 90/80x200	2	Spring retainers 10/60-80
1.5	1	1000	g	1	Ø 90/80x330	1	Axle retainer 40x10x140
2.1	1	2983	e	1	Ø 90/80x200	1	Spring retainers 10/60-80
2.2	2	9300	e	2	Ø 90/80x200	2	Spring retainers 10/60-80
3.1	1	5000	h	1	Ø 70/60x167	1	Locking pin 12x75
3.2	1	3100	h	1	Ø 70/60x167	1	Locking pin 12x75
3.3	1	9662	h	1	Ø 70/60x167	1	Locking pin 12x75
3.4	1	1000	h	1	Ø 70/60x167	1	Locking pin 12x75
			i	1	Ø 70/60x275	1	Axle retainer 30x8x100
4.1	3	9253	h	3	Ø 70/60x167	3	Locking pin 12x75
4.2	1	2500	h	1	Ø 70/60x167	1	Locking pin 12x75
4.3	1	7634	h	2	Ø 70/60x167	2	Locking pin 12x75
5.1	1	4619	h	1	Ø 70/60x167	1	Locking pin 12x75
5.3	1	1000	h	1	Ø 70/60x167	1	Locking pin 12x75
			k	1	Ø 70/60x255	1	Axle retainer 30x8x100
Bracing block 1 and 2			b	4	Ø 65/55x125	4	Locking pin 12x75

Jib brace diagram 65m - 60m

single bracing

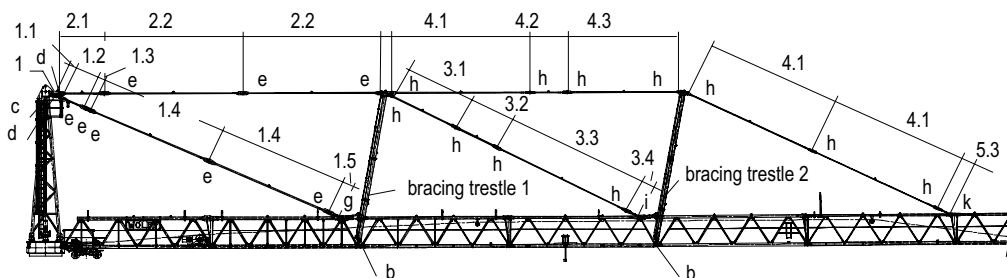

Bolt table

Brace			Ref.	Bolts		Fuse	
Ref.	Quantity	Hole pitch [mm]		Quantity	Dimension [mm]	Quantity	Dimension [mm]
1	1		c	1	Ø 120/100x310	1	Axle retainer 40x10x140
		307	d	1	Ø 100/80x240	1	Axle retainer 40x10x140
		560	d	1	Ø 100/80x240	1	Axle retainer 40x10x140
1.1	1	400	e	1	Ø 90/80x200	1	Spring retainers 10/60-80
1.2	1	1805	e	1	Ø 90/80x200	1	Spring retainers 10/60-80
1.3	1	320	e	1	Ø 90/80x200	1	Spring retainers 10/60-80
1.4	2	8700	e	2	Ø 90/80x200	2	Spring retainers 10/60-80
1.5	1	1000	g	1	Ø 90/80x330	1	Axle retainer 40x10x140
2.1	1	2983	e	1	Ø 90/80x200	1	Spring retainers 10/60-80
2.2	2	9300	e	2	Ø 90/80x200	2	Spring retainers 10/60-80
3.1	1	5000	h	1	Ø 70/60x167	1	Locking pin 12x75
3.2	1	3100	h	1	Ø 70/60x167	1	Locking pin 12x75
3.3	1	9662	h	1	Ø 70/60x167	1	Locking pin 12x75
3.4	1	1000	h	1	Ø 70/60x167	1	Locking pin 12x75
			i	1	Ø 70/60x275	1	Axle retainer 30x8x100
4.1	3	9253	h	3	Ø 70/60x167	3	Locking pin 12x75
4.2	1	2500	h	1	Ø 70/60x167	1	Locking pin 12x75
4.3	1	7634	h	2	Ø 70/60x167	2	Locking pin 12x75
5.3	1	1000	h	1	Ø 70/60x167	1	Locking pin 12x75
			k	1	Ø 70/60x255	1	Axle retainer 30x8x100
Bracing block 1 and 2			b	4	Ø 65/55x125	4	Locking pin 12x75

Jib brace diagram 55m - 50m

single bracing

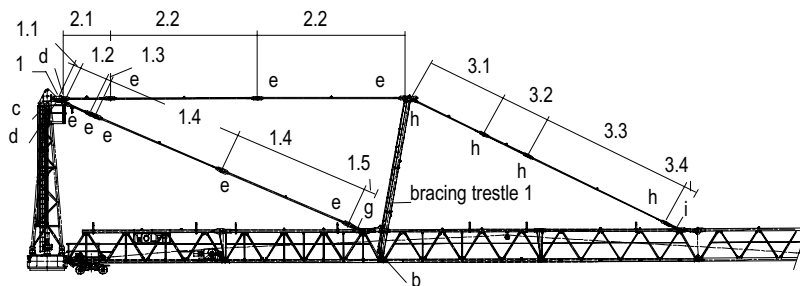

Bolt table

Brace			Ref.	Bolts		Fuse	
Ref.	Quantity	Hole pitch [mm]		Quantity	Dimension [mm]	Quantity	Dimension [mm]
1	1		c	1	Ø 120/100x310	1	Axle retainer 40x10x140
		307	d	1	Ø 100/80x240	1	Axle retainer 40x10x140
		560	d	1	Ø 100/80x240	1	Axle retainer 40x10x140
1.1	1	400	e	1	Ø 90/80x200	1	Spring retainers 10/60-80
1.2	1	1805	e	1	Ø 90/80x200	1	Spring retainers 10/60-80
1.3	1	320	e	1	Ø 90/80x200	1	Spring retainers 10/60-80
1.4	2	8700	e	2	Ø 90/80x200	2	Spring retainers 10/60-80
1.5	1	1000	g	1	Ø 90/80x330	1	Axle retainer 40x10x140
2.1	1	2983	e	1	Ø 90/80x200	1	Spring retainers 10/60-80
2.2	2	9300	e	2	Ø 90/80x200	2	Spring retainers 10/60-80
3.1	1	5000	h	1	Ø 70/60x167	1	Locking pin 12x75
3.2	1	3100	h	1	Ø 70/60x167	1	Locking pin 12x75
3.3	1	9662	h	1	Ø 70/60x167	1	Locking pin 12x75
3.4	1	1000	h	1	Ø 70/60x167	1	Locking pin 12x75
			i	1	Ø 70/60x275	1	Axle retainer 30x8x100
Bracing block 1 and 2			b	4	Ø 65/55x125	4	Locking pin 12x75

Brace diagram for jib 30m

single bracing

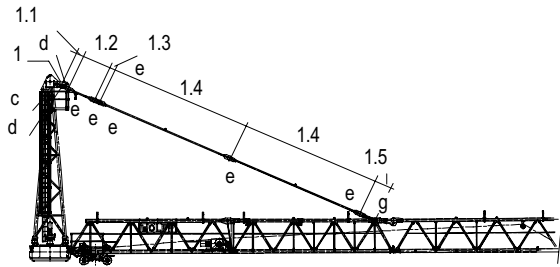

Bolt table

Brace			Ref.	Bolts		Fuse	
Ref.	Quantity	Hole pitch [mm]		Quantity	Dimension [mm]	Quantity	Dimension [mm]
1	1		c	1	Ø 120/100x310	1	Axle retainer 40x10x140
		307	d	1	Ø 100/80x240	1	Axle retainer 40x10x140
		560	d	1	Ø 100/80x240	1	Axle retainer 40x10x140
1.1	1	400	e	1	Ø 90/80x200	1	Spring retainers 10/60-80
1.2	1	1805	e	1	Ø 90/80x200	1	Spring retainers 10/60-80
1.3	1	320	e	1	Ø 90/80x200	1	Spring retainers 10/60-80
1.4	2	8700	e	2	Ø 90/80x200	2	Spring retainers 10/60-80
1.5	1	1000	g	1	Ø 90/80x330	1	Axle retainer 40x10x140
Bracing block 1 and 2			b	4	Ø 65/55x125	4	Locking pin 12x75

Jib brace diagram 85m - 75m

single reeving

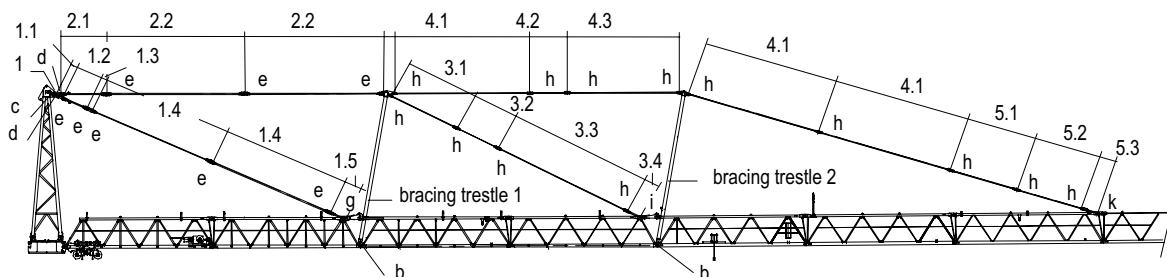

Bolt table

Brace			Ref.	Bolts		Fuse	
Ref.	Quantity	Hole pitch [mm]		Quantity	Dimension [mm]	Quantity	Dimension [mm]
1	1	-	c	1	Ø 120/100x310	1	Locking pin 12x75
		307	d	1	Ø 100/80x240	1	Axle retainer 40x10x140
		560	d	1	Ø 100/80x240	1	Axle retainer 40x10x140
1.1	1	400	e	1	Ø 90/80x200	1	Axle retainer 40x10x140
1.2	1	1805	e	1	Ø 90/80x200	1	Spring retainers 10/60-80
1.3	1	320	e	1	Ø 90/80x200	1	Spring retainers 10/60-80
1.4	2	8700	e	2	Ø 90/80x200	2	Spring retainers 10/60-80
1.5	1	1000	g	1	Ø 90/80x330	1	Axle retainer 40x10x140
2.1	1	2983	e	1	Ø 90/80x200	1	Spring retainers 10/60-80
2.2	2	9300	e	2	Ø 90/80x200	2	Spring retainers 10/60-80
3.1	1	5000	h	1	Ø 70/60x167	1	Locking pin 12x75
3.2	1	3100	h	1	Ø 70/60x167	1	Locking pin 12x75
3.3	1	9662	h	1	Ø 70/60x167	1	Locking pin 12x75
3.4	1	1000	h	1	Ø 70/60x167	1	Locking pin 12x75
			i	1	Ø 70/60x275	1	Axle retainer 30x8x100
4.1	3	9253	h	3	Ø 70/60x167	3	Locking pin 12x75
4.2	1	2500	h	1	Ø 70/60x167	1	Locking pin 12x75
4.3	1	7634	h	2	Ø 70/60x167	2	Locking pin 12x75
5.1	1	4619	h	1	Ø 70/60x167	1	Locking pin 12x75
5.2	1	4745	h	1	Ø 70/60x167	1	Locking pin 12x75
5.3	1	1000	h	1	Ø 70/60x167	1	Locking pin 12x75
			k	1	Ø 70/60x255	1	Axle retainer 30x8x100
Bracing block 1 and 2			b	4	Ø 65/55x125	4	Locking pin 12x75

Jib brace diagram 70m - 60m

single bracing

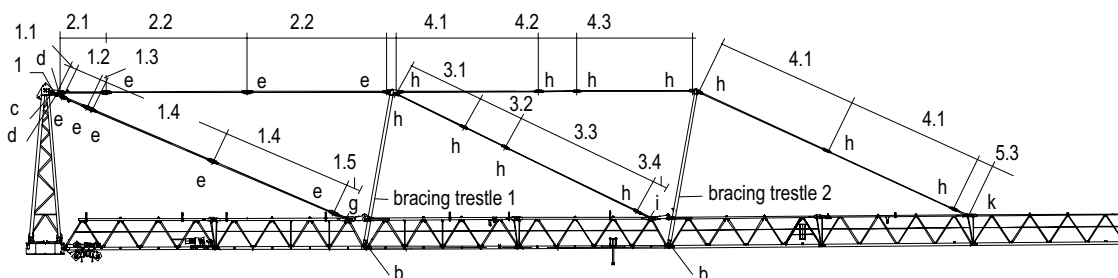

Bolt table

Brace			Ref.	Bolts		Fuse	
Ref.	Quantity	Hole pitch [mm]		Quantity	Dimension [mm]	Quantity	Dimension [mm]
1	1	-	c	1	Ø 120/100x310	1	Locking pin 12x75
		307	d	1	Ø 100/80x240	1	Axle retainer 40x10x140
		560	d	1	Ø 100/80x240	1	Axle retainer 40x10x140
1.1	1	400	e	1	Ø 90/80x200	1	Axle retainer 40x10x140
1.2	1	1805	e	1	Ø 90/80x200	1	Spring retainers 10/60-80
1.3	1	320	e	1	Ø 90/80x200	1	Spring retainers 10/60-80
1.4	2	8700	e	2	Ø 90/80x200	2	Spring retainers 10/60-80
1.5	1	1000	g	1	Ø 90/80x330	1	Axle retainer 40x10x140
2.1	1	2983	e	1	Ø 90/80x200	1	Spring retainers 10/60-80
2.2	2	9300	e	2	Ø 90/80x200	2	Spring retainers 10/60-80
3.1	1	5000	h	1	Ø 70/60x167	1	Locking pin 12x75
3.2	1	3100	h	1	Ø 70/60x167	1	Locking pin 12x75
3.3	1	9662	h	1	Ø 70/60x167	1	Locking pin 12x75
3.4	1	1000	h	1	Ø 70/60x167	1	Locking pin 12x75
			i	1	Ø 70/60x275	1	Axle retainer 30x8x100
4.1	3	9253	h	3	Ø 70/60x167	3	Locking pin 12x75
4.2	1	2500	h	1	Ø 70/60x167	1	Locking pin 12x75
4.3	1	7634	h	2	Ø 70/60x167	2	Locking pin 12x75
5.3	1	1000	h	1	Ø 70/60x167	1	Locking pin 12x75
			k	1	Ø 70/60x255	1	Axle retainer 30x8x100
Bracing block 1 and 2			b	4	Ø 65/55x125	4	Locking pin 12x75

Jib brace diagram 55m - 40m

single bracing

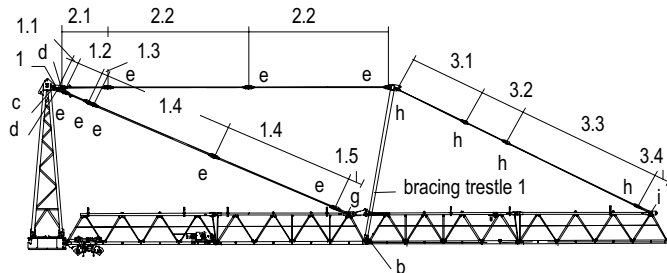

Bolt table

Brace			Ref.	Bolts		Fuse	
Ref.	Quantity	Hole pitch [mm]		Quantity	Dimension [mm]	Quantity	Dimension [mm]
1	1	-	c	1	Ø 120/100x310	1	Locking pin 12x75
		307	d	1	Ø 100/80x240	1	Axle retainer 40x10x140
		560	d	1	Ø 100/80x240	1	Axle retainer 40x10x140
1.1	1	400	e	1	Ø 90/80x200	1	Axle retainer 40x10x140
1.2	1	1805	e	1	Ø 90/80x200	1	Spring retainers 10/60-80
1.3	1	320	e	1	Ø 90/80x200	1	Spring retainers 10/60-80
1.4	2	8700	e	2	Ø 90/80x200	2	Spring retainers 10/60-80
1.5	1	1000	g	1	Ø 90/80x330	1	Axle retainer 40x10x140
2.1	1	2983	e	1	Ø 90/80x200	1	Spring retainers 10/60-80
2.2	2	9300	e	2	Ø 90/80x200	2	Spring retainers 10/60-80
3.1	1	5000	h	1	Ø 70/60x167	1	Locking pin 12x75
3.2	1	3100	h	1	Ø 70/60x167	1	Locking pin 12x75
3.3	1	9662	h	1	Ø 70/60x167	1	Locking pin 12x75
3.4	1	1000	h	1	Ø 70/60x167	1	Locking pin 12x75
			i	1	Ø 70/60x275	1	Axle retainer 30x8x100
Bracing block 1 and 2			b	4	Ø 65/55x125	4	Locking pin 12x75

Brace diagram for jib 30m

single bracing

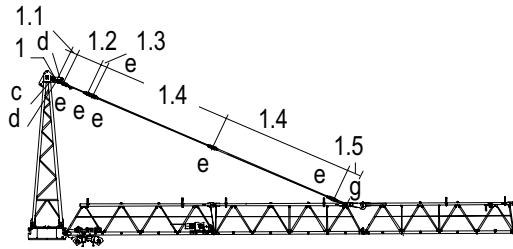

Bolt table

Brace			Ref.	Bolts		Fuse	
Ref.	Quantity	Hole pitch [mm]		Quantity	Dimension [mm]	Quantity	Dimension [mm]
1	1	-	c	1	Ø 120/100x310	1	Locking pin 12x75
		307	d	1	Ø 100/80x240	1	Axle retainer 40x10x140
		560	d	1	Ø 100/80x240	1	Axle retainer 40x10x140
1.1	1	400	e	1	Ø 90/80x200	1	Axle retainer 40x10x140
1.2	1	1805	e	1	Ø 90/80x200	1	Spring retainers 10/60-80
1.3	1	320	e	1	Ø 90/80x200	1	Spring retainers 10/60-80
1.4	2	8700	e	2	Ø 90/80x200	2	Spring retainers 10/60-80
1.5	1	1000	g	1	Ø 90/80x330	1	Axle retainer 40x10x140

Brace diagram for jib 90m

single bracing

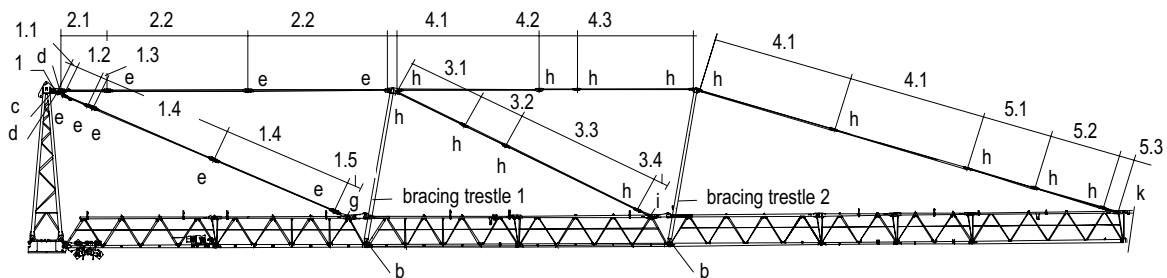

Bolt table

Brace			Ref.	Bolts		Fuse	
Ref.	Quantity	Hole pitch [mm]		Quantity	Dimension [mm]	Quantity	Dimension [mm]
1	1	-	c	1	Ø 120/100x310	1	Axle retainer 40x10x140
		327	d	1	Ø 90/70x240	1	Axle retainer 40x10x140
		530	d	1	Ø 80/70x240	1	Axle retainer 40x10x140

Brace			Ref.	Bolts		Fuse	
Ref.	Quantity	Hole pitch [mm]		Quantity	Dimension [mm]	Quantity	Dimension [mm]
1.1	1	400	e	1	Ø 80/70x180	1	Spring retainers 10/60-80
1.2	1	1805	e	1	Ø 80/70x180	1	Spring retainers 10/60-80
1.3	1	300	e	1	Ø 80/70x180	1	Spring retainers 10/60-80
1.4	2	8700	e	2	Ø 80/70x180	2	Spring retainers 10/60-80
1.5	1	1000	g	1	Ø 80/70x280	1	Axle retainer 40x10x140
2.1	1	3035	e	1	Ø 80/70x180	1	Spring retainers 10/60-80
2.2	2	9300	e	2	Ø 80/70x180	2	Spring retainers 10/60-80
3.1	1	5000	h	1	Ø 65/55x150	1	Locking pin 12x75
3.2	1	3100	h	1	Ø 65/55x150	1	Locking pin 12x75
3.3	1	9662	h	1	Ø 65/55x150	1	Locking pin 12x75
3.4	1	1000	h	1	Ø 65/55x150	1	Locking pin 12x75
			i	1	Ø 65/55x240	1	Axle retainer 30x8x100
4.1	3	9253	h	3	Ø 65/55x150	3	Locking pin 12x75
4.2	1	2500	h	1	Ø 65/55x150	1	Locking pin 12x75
4.3	1	7634	h	2	Ø 65/55x150	2	Locking pin 12x75
5.1	1	4619	h	1	Ø 65/55x150	1	Locking pin 12x75
5.2	1	4745	h	1	Ø 65/55x150	1	Locking pin 12x75
5.3	1	1000	h	1	Ø 65/55x150	1	Locking pin 12x75
			k	1	Ø 65/55x220	1	Axle retainer 30x8x100
Bracing block 1 and 2			b	4	Ø 60/50x115	4	Spring retainers 6/50

Jib brace diagram 85m – 75m

single bracing

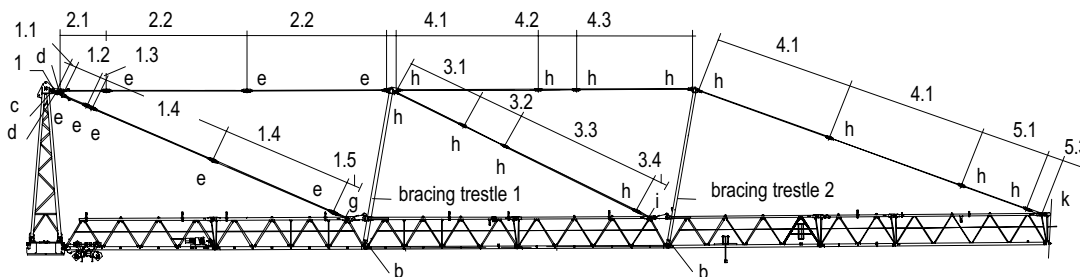

Bolt table

Brace			Ref.	Bolts		Fuse	
Ref.	Quantity	Hole pitch [mm]		Quantity	Dimension [mm]	Quantity	Dimension [mm]
1	1	-	c	1	Ø 120/100x310	1	Axle retainer 40x10x140
		327	d	1	Ø 90/70x240	1	Axle retainer 40x10x140
		530	d	1	Ø 80/70x240	1	Axle retainer 40x10x140

Brace			Ref.	Bolts		Fuse	
Ref.	Quantity	Hole pitch [mm]		Quantity	Dimension [mm]	Quantity	Dimension [mm]
1.1	1	400	e	1	Ø 80/70x180	1	Spring retainers 10/60-80
1.2	1	1805	e	1	Ø 80/70x180	1	Spring retainers 10/60-80
1.3	1	300	e	1	Ø 80/70x180	1	Spring retainers 10/60-80
1.4	2	8700	e	2	Ø 80/70x180	2	Spring retainers 10/60-80
1.5	1	1000	g	1	Ø 80/70x280	1	Axle retainer 40x10x140
2.1	1	3035	e	1	Ø 80/70x180	1	Spring retainers 10/60-80
2.2	2	9300	e	2	Ø 80/70x180	2	Spring retainers 10/60-80
3.1	1	5000	h	1	Ø 65/55x150	1	Locking pin 12x75
3.2	1	3100	h	1	Ø 65/55x150	1	Locking pin 12x75
3.3	1	9662	h	1	Ø 65/55x150	1	Locking pin 12x75
3.4	1	1000	h	1	Ø 65/55x150	1	Locking pin 12x75
			i	1	Ø 65/55x240	1	Axle retainer 30x8x100
4.1	3	9253	h	3	Ø 65/55x150	3	Locking pin 12x75
4.2	1	2500	h	1	Ø 65/55x150	1	Locking pin 12x75
4.3	1	7634	h	2	Ø 65/55x150	2	Locking pin 12x75
5.1	1	4619	h	1	Ø 65/55x150	1	Locking pin 12x75
5.3	1	1000	h	1	Ø 65/55x150	1	Locking pin 12x75
			k	1	Ø 65/55x220	1	Axle retainer 30x8x100
Bracing block 1 and 2			b	4	Ø 60/50x115	4	Spring retainers 6/50

Jib brace diagram 70m – 60m

single bracing

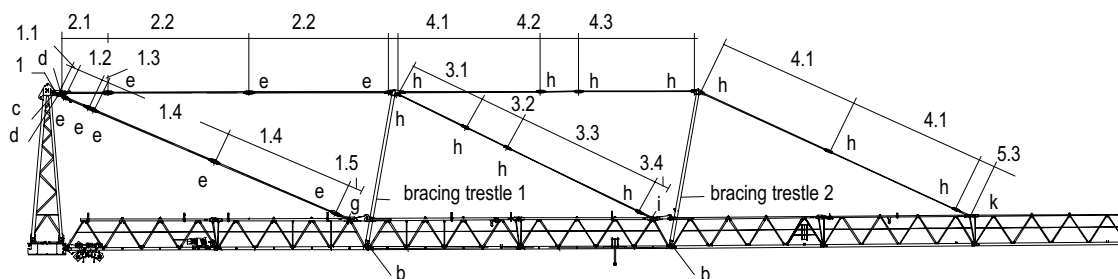

Bolt table

Brace			Ref.	Bolts		Fuse	
Ref.	Quantity	Hole pitch [mm]		Quantity	Dimension [mm]	Quantity	Dimension [mm]
1	1	-	c	1	Ø 120/100x310	1	Axle retainer 40x10x140
		327	d	1	Ø 90/70x240	1	Axle retainer 40x10x140
		530	d	1	Ø 80/70x240	1	Axle retainer 40x10x140
1.1	1	400	e	1	Ø 80/70x180	1	Spring retainers 10/60-80

Brace			Ref.	Bolts		Fuse	
Ref.	Quantity	Hole pitch [mm]		Quantity	Dimension [mm]	Quantity	Dimension [mm]
1.2	1	1805	e	1	Ø 80/70x180	1	Spring retainers 10/60-80
1.3	1	300	e	1	Ø 80/70x180	1	Spring retainers 10/60-80
1.4	2	8700	e	2	Ø 80/70x180	2	Spring retainers 10/60-80
1.5	1	1000	g	1	Ø 80/70x280	1	Axle retainer 40x10x140
2.1	1	3035	e	1	Ø 80/70x180	1	Spring retainers 10/60-80
2.2	2	9300	e	2	Ø 80/70x180	2	Spring retainers 10/60-80
3.1	1	5000	h	1	Ø 65/55x150	1	Locking pin 12x75
3.2	1	3100	h	1	Ø 65/55x150	1	Locking pin 12x75
3.3	1	9662	h	1	Ø 65/55x150	1	Locking pin 12x75
3.4	1	1000	h	1	Ø 65/55x150	1	Locking pin 12x75
			i	1	Ø 65/55x240	1	Axle retainer 30x8x100
4.1	3	9253	h	3	Ø 65/55x150	3	Locking pin 12x75
4.2	1	2500	h	1	Ø 65/55x150	1	Locking pin 12x75
4.3	1	7634	h	2	Ø 65/55x150	2	Locking pin 12x75
5.3	1	1000	h	1	Ø 65/55x150	1	Locking pin 12x75
			k	1	Ø 65/55x220	1	Axle retainer 30x8x100
Bracing block 1 and 2			b	4	Ø 60/50x115	4	Spring retainers 6/50

Jib brace diagram 55m – 40m

single bracing

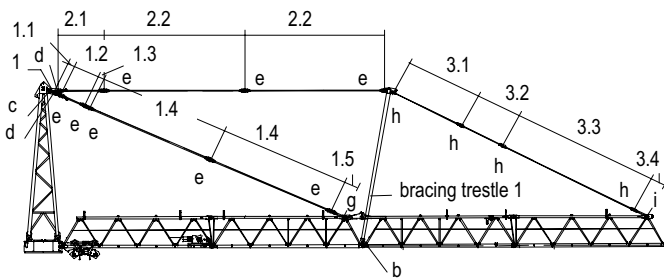

Bolt table

Brace			Ref.	Bolts		Fuse	
Ref.	Quantity	Hole pitch [mm]		Quantity	Dimension [mm]	Quantity	Dimension [mm]
1	1	-	c	1	Ø 120/100x310	1	Axle retainer 40x10x140
		327	d	1	Ø 90/70x240	1	Axle retainer 40x10x140
		530	d	1	Ø 80/70x240	1	Axle retainer 40x10x140
1.1	1	400	e	1	Ø 80/70x180	1	Spring retainers 10/60-80
1.2	1	1805	e	1	Ø 80/70x180	1	Spring retainers 10/60-80

Brace			Ref.	Bolts		Fuse	
Ref.	Quantity	Hole pitch [mm]		Quantity	Dimension [mm]	Quantity	Dimension [mm]
1.3	1	300	e	1	Ø 80/70x180	1	Spring retainers 10/60-80
1.4	2	8700	e	2	Ø 80/70x180	2	Spring retainers 10/60-80
1.5	1	1000	g	1	Ø 80/70x280	1	Axle retainer 40x10x140
2.1	1	3035	e	1	Ø 80/70x180	1	Spring retainers 10/60-80
2.2	2	9300	e	2	Ø 80/70x180	2	Spring retainers 10/60-80
3.1	1	5000	h	1	Ø 65/55x150	1	Locking pin 12x75
3.2	1	3100	h	1	Ø 65/55x150	1	Locking pin 12x75
3.3	1	9662	h	1	Ø 65/55x150	1	Locking pin 12x75
3.4	1	1000	h	1	Ø 65/55x150	1	Locking pin 12x75
			i	1	Ø 65/55x240	1	Axle retainer 30x8x100
Bracing block 1 and 2			b	4	Ø 60/50x115	4	Spring retainers 6/50

Jib brace diagram 35m – 30m

single bracing

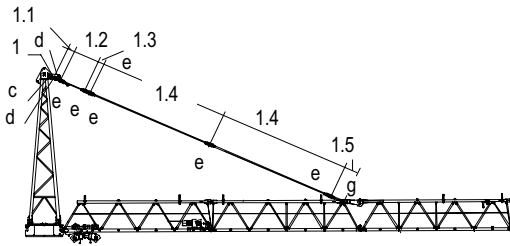

Bolt table

Brace			Ref.	Bolts		Fuse	
Ref.	Quantity	Hole pitch [mm]		Quantity	Dimension [mm]	Quantity	Dimension [mm]
1	1	-	c	1	Ø 120/100x310	1	Axle retainer 40x10x140
		327	d	1	Ø 90/70x240	1	Axle retainer 40x10x140
		530	d	1	Ø 80/70x240	1	Axle retainer 40x10x140
1.1	1	400	e	1	Ø 80/70x180	1	Spring retainers 10/60-80
1.2	1	1805	e	1	Ø 80/70x180	1	Spring retainers 10/60-80
1.3	1	300	e	1	Ø 80/70x180	1	Spring retainers 10/60-80
1.4	2	8700	e	2	Ø 80/70x180	2	Spring retainers 10/60-80
1.5	1	1000	g	1	Ø 80/70x280	1	Axle retainer 40x10x140
Bracing block 1 and 2			b	4	Ø 60/50x115	4	Spring retainers 6/50

Brace diagram 80.0 m – 57.5 m

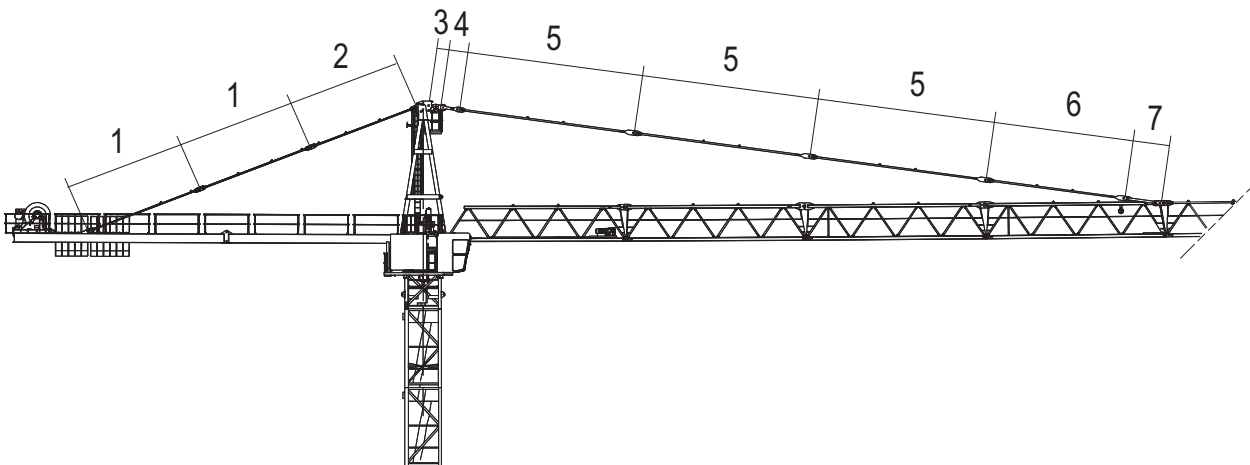

Brace table

Brace	Lengths [mm]							Brace types
	Brace no. 1	Brace no. 2	Brace no. 3	Brace no. 4	Brace no. 5	Brace no. 6	Brace no. 7	
Counter jib	6579	6225	-	-	-	-	-	double
Jib	-	-	400	1210	9856	7752	2020	single

Bolt table brace 80.0 m – 57.5 m

Item	Brace	Fastening			Fuse		
		Quantity	Designation	Dimensions	Quantity	Component	Dimensions
Counter jib brace	1	4	Bolts	Ø 70/60x152	4	Spring retainers	10/60-80
	2	2	Bolts	Ø 70/60x152	2	Spring retainers	10/60-80
Jib brace	3	1	Bolts	Ø 100/90x235	1	Cotter pin	13x125
	4	2	Bolts	Ø 100/90x225	2	Cotter pin	13x125
					2	Washer	130/91x4
	5	3	Bolts	Ø 100/90x225	3	Cotter pin	13x125
	6	1	Bolts	Ø 100/90x225	1	Cotter pin	13x125
	7	1	Collar bolt	Ø 110/90x325	1	Axle retainer	40x10x140
					2	Lock washer	A16
2					Hexagonal head screw	M16x40-8.8	

Brace diagram 55.0 m – 30.0 m

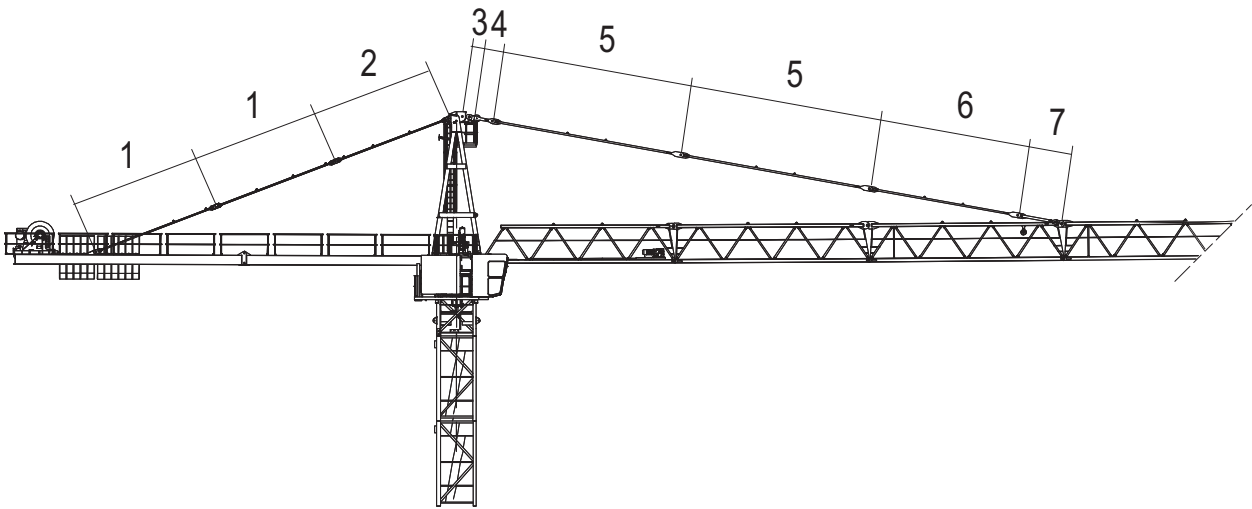

Brace table

Brace	Lengths [mm]							Brace types
	Brace no. 1	Brace no. 2	Brace no. 3	Brace no. 4	Brace no. 5	Brace no. 6	Brace no. 7	
Counter jib	6579	6225	-	-	-	-	-	double
Jib	-	-	400	1210	9856	7752	2020	single

Bolt table brace 80.0 m – 57.5 m

Item	Brace	Fastening			Fuse		
		Quantity	Designation	Dimensions	Quantity	Component	Dimensions
Counter jib brace	1	4	Bolts	Ø 70/60x152	4	Spring retainers	10/60-80
	2	2	Bolts	Ø 70/60x152	2	Spring retainers	10/60-80
Jib brace	3	1	Bolts	Ø 100/90x235	1	Cotter pin	13x125
	4	2	Bolts	Ø 100/90x225	2	Cotter pin	13x125
					2	Washer	130/91x4
	5	2	Bolts	Ø 100/90x225	2	Cotter pin	13x125
	6	1	Bolts	Ø 100/90x225	1	Cotter pin	13x125
	7	1	Collar bolt	Ø 110/90x325	1	Axle retainer	40x10x140
				2	Lock washer	A16	
				2	Hexagonal head screw	M16x40-8.8	

7.3 Trolley jib mounting rig

	NOTICE
	For information on the arrangement of the mounting rig, refer to the attachment diagram.
	Two mounting rigs are required per slewing tower crane.

Elements required for each mounting rig

Quantity	Item	Dimensions	Material
1	Mounting rig		
4	Hexagonal head bolt	M16 x 240	ISO 4017-8.8 galv.
8	HSFG washer	17	EN 14399 galvanized
8	Hexagonal nut	M16	ISO 4032-8 galvanized

Mounting rig

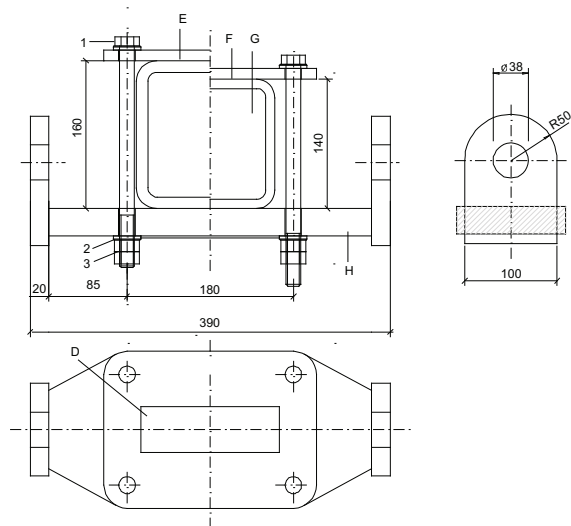

1	Hexagonal head screw	A	Mounting rig
2	HSFG washer	W	Top belt trolley jib
3	Hexagonal nut		

7.4 Arrangement of standard railings

7.4.1 Standard railings (NG) and accessories

Quant- ity	Standard railings (NG) / accessories	Article no.
9	Standard railings NG 2500	30018798
14	Standard railings NG 2000	30018797
3	Standard railings NG 1500	30018796
5	Standard railings NG 1000	30018795
2	Standard railings NG 750	30018794
11	Standard railings NG 500	30018793
4	Standard stays Ø 42.4 mm x 1090 mm	30000167
1	RS (back guard)	30044244
1	support block AB 1 645 mm	30050695
1	support block AB 2 1140 mm	30050697

7.4.2 Arrangement of standard railings

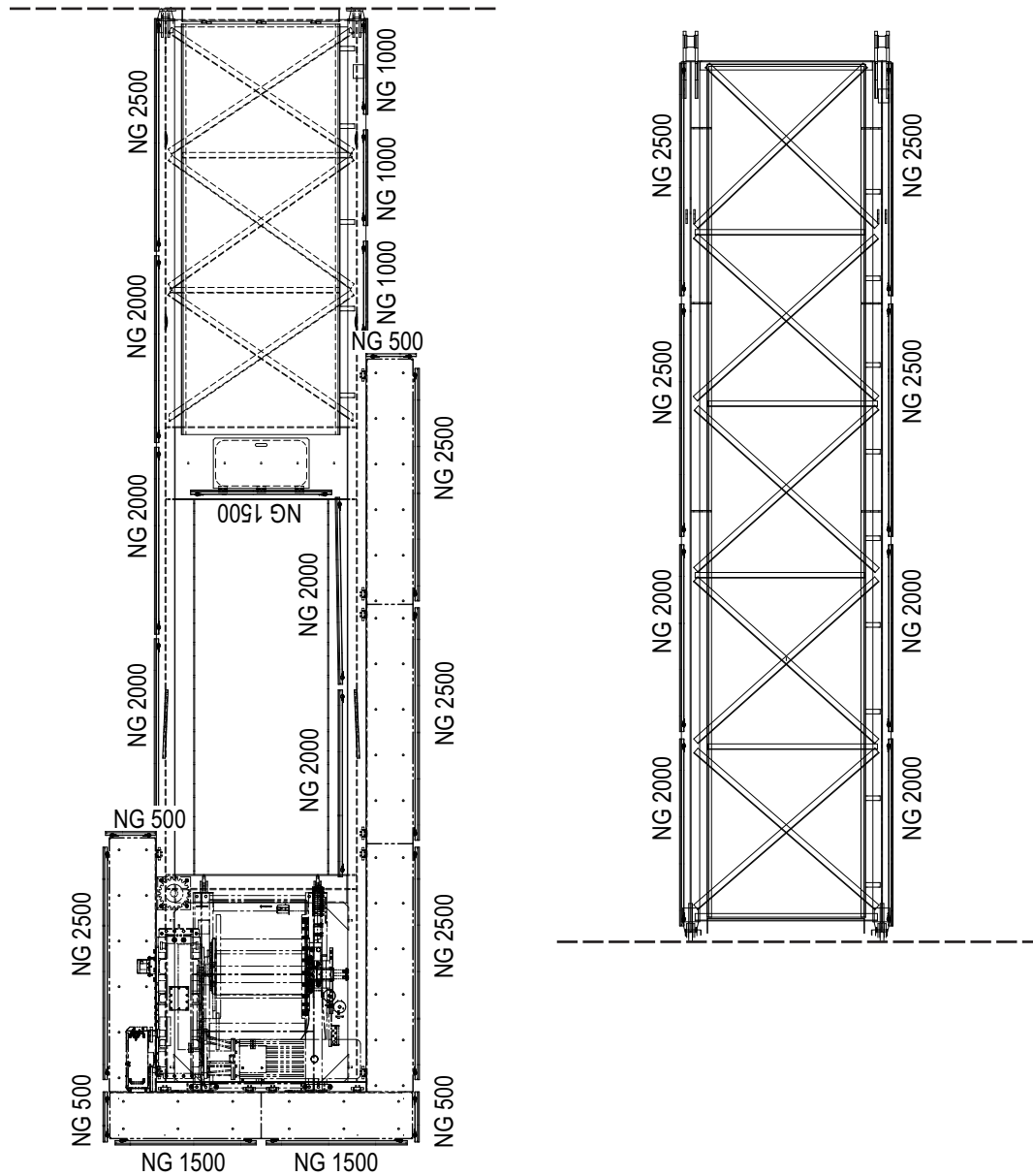

Arrangement of standard railings, counterjib

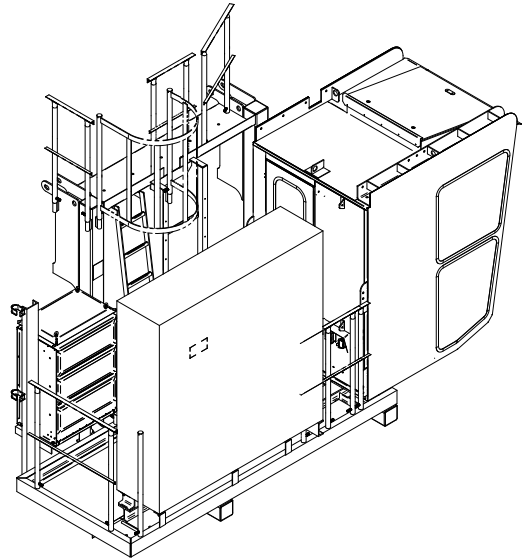
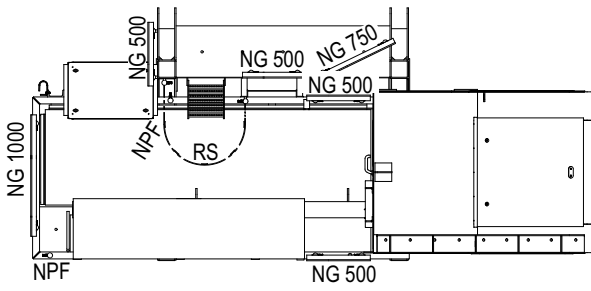

Arrangement of standard railings, operator cabin

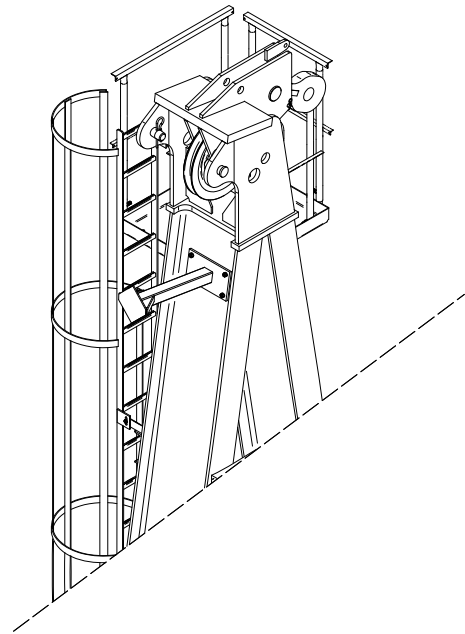
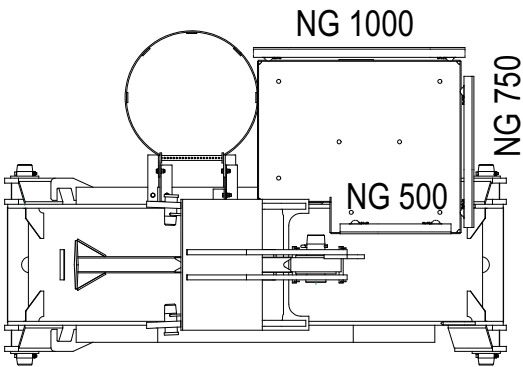

Arrangement of standard railings, tower head section

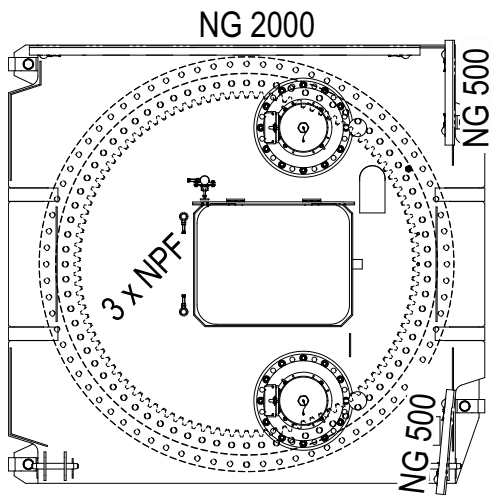

Arrangement of standard railings, slewing frame

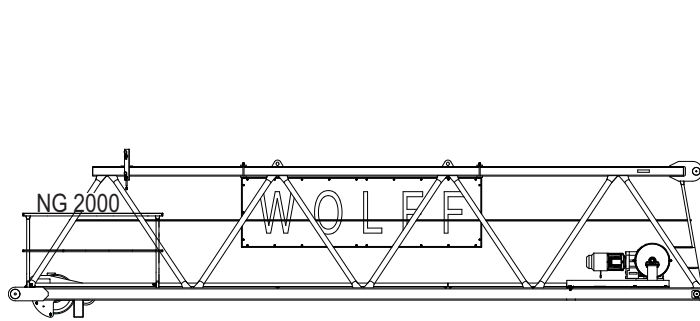
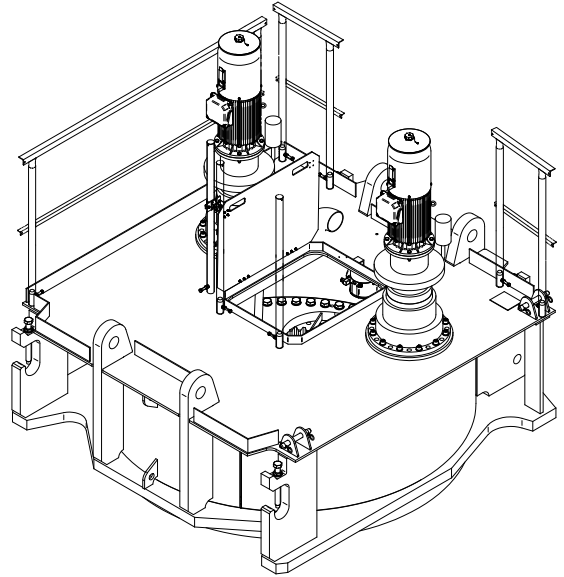

Arrangement of standard railings, jib element 1

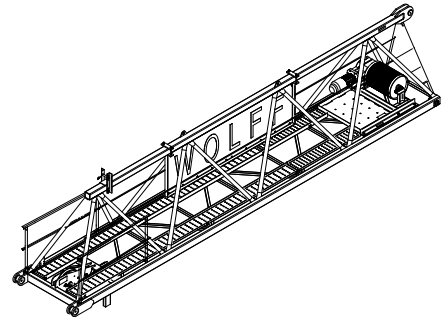



8 Suitable climbing frames

This section contains information on

- Outer climbing units
- Inner climbing units (KSH)

	⚠ WARNING
	<p>Climbing unit attached to the cat head bottom section Increased wind surface. The slewing tower crane may overturn.</p> <ol style="list-style-type: none"> 1) Lower the climbing unit down on the tower, or 2) dismantle the climbing unit.

	NOTICE
	<p>Clamping forces for the inner climbing unit (KSH) are specified based on a building height of < 250m and wind category C 25</p>



	NOTICE
	<p>The operating radius specified is measured from the tower center and is to be considered a reference value. Exact balancing can be achieved by moving the trolley with the tower elements specified in the table or a load and can be checked by moving the end stops of the tower apart without offsets.</p>

	NOTICE
	<p>The data required and the instructions for tower assemblies with inner climbing unit is available in the separate description of the inner climbing unit.</p>

DANGER! Observe the special tower combination for the inner climbing unit.

	NOTICE
	<p>Details for climbing balancing The climbing balancing details apply to the snatch block in maximum hook position.</p>

8.1 Outer climbing units

	<p>NOTICE</p> <p>If feasible, you should preferably operate your climbing frame without balancing weight.</p>
	<p>NOTICE</p> <p>Tower element on the transfer carriage</p> <p>The data on climbing balance was specified under the assumption that a tower element is on the transfer carriage.</p>

8.1.1 Outer climbing unit KWH 20.6/ KWH 20.6.1

	NOTICE
	<p>Minimum height for stationary setup: 2 tower elements = 9.0 m tower height</p> <p>Minimum height for crawling towers: 2 tower elements + bogie truck = approx. 13.5 m tower height</p>

Climbing radius 8033.20 cross

Climbing radius for the balancing weights

8033.20	Jib length [m]						
	80	77.5	75	72.5	70	67.5	65
no weight	22.9	27.9	56.6	-	-	-	-
TV 20 = 2.98 t	7.1	8.8	18.7	25.6	24.5	26.5	25.6
Weight = 5.0 t	-	5.7	12.5	17.4	16.6	18.0	17.4
Weight = 10.0 t	-	-	-	-	-	-	-

Climbing radius for the balancing weights

8033.20	Jib length [m]						
	62.5	60	57.5	55	52.5	50	47.5
no weight	-	-	-	-	-	-	-
TV 20 = 2.98 t	32.0	30.6	35.3	38.0	36.1	39.3	38.1
Weight = 5.0 t	21.8	20.8	24.1	25.9	24.6	26.8	26.0
Weight = 10.0 t	-	-	-	-	-	-	-

Climbing radius for the balancing weights

8033.20	Jib length [m]						
	45	42.5	40	37.5	35	32.5	30
no weight	-	-	-	-	-	-	-
TV 20 = 2.98 t	36.8	39.2	-	-	-	-	-
Weight = 5.0 t	25.1	26.7	25.4	25.8	27.1	29.7	-
Weight = 10.0 t	-	-	-	-	-	-	15.8

8.1.2 Outer climbing unit KWH 23

	NOTICE
	<p>Climbing radiuses marked with *</p> <p>Jib lengths marked with * can only be climbed with additional ballast. Please contact WOLFFKRAN for information.</p>

	NOTICE
	<p>Usage of KWH 23 on WOLFF 8033 with TV 20 lower part of tower head section</p> <p>You must use a joining frame VR 2023 to operate the outer climbing unit KWH 23 in connection with the WOLFF 8033 on TV 20 tower head section lower part.</p>

Climbing radius 8033.20 cross

Climbing radius for the balancing weights, lower part of tower head section TV 20 with outer climbing unit

8033.20	Jib length [m]						
	80	77.5	75	72.5	70	67.5	65
without weight	*	*	40.0	-	-	-	-
TV 23 = 3.04 t	-	-	12.7	19.5	18.6	20.4	19.7
Weight = 5.0 t	-	-	8.5	13.3	12.6	13.9	13.4

Climbing radius for the balancing weights, lower part of tower head section TV 20 with outer climbing unit

8033.20	Jib length [m]						
	62.5	60	57.5	55	52.5	50	47.5
without weight	-	-	-	-	-	-	-
TV 23 = 3.04 t	26.0	24.7	29.3	32.2	30.5	33.7	32.5
Weight = 5.0 t	17.8	16.9	20.1	22.2	21.0	23.2	22.4

Climbing radius for the balancing weights, lower part of tower head section TV 20 with outer climbing unit

8033.20	Jib length [m]						
	45	42.5	40	37.5	35	32.5	30
without weight	-	-	-	-	-	-	-
TV 23 = 3.04 t	31.3	33.7	32.0	32.4	-	-	-
Weight = 5.0 t	21.5	23.2	22.0	22.3	23.7	26.2	25.5

Climbing radius for the balancing weights, lower part of tower head section HT 23 with outer climbing unit

8033.20	Jib length [m]						
	80	77.5	75	72.5	70	67.5	65
without weight	*	*	38.4	-	-	-	-
HT 23 = 3.94 t	-	-	9.9	15.7	14.9	16.4	15.8
Weight = 5.0 t	-	-	8.1	12.9	12.3	13.5	13.0

Climbing radius for the balancing weights, lower part of tower head section HT 23 with outer climbing unit

8033.20	Jib length [m]						
	62.5	60	57.5	55	52.5	50	47.5
without weight	-	-	-	-	-	-	-
HT 23 = 3.94 t	21.1	20.0	23.8	26.3	24.8	27.5	26.5
Weight = 5.0 t	17.4	16.5	19.7	21.8	20.6	22.8	22.0

Climbing radius for the balancing weights, lower part of tower head section HT 23 with outer climbing unit

8033.20	Jib length [m]						
	45	42.5	40	37.5	35	32.5	30
without weight	-	-	-	-	-	-	-
HT 23 = 3.94 t	25.5	27.5	26.1	26.4	28.0	-	-
Weight = 5.0 t	21.2	22.8	21.6	21.9	23.3	25.9	25.1

8.2 Inner climbing units

8.2.1 Inner climbing unit KSH 20 SH

Tower combinations for slewing tower cranes with inner climbing unit.

Item				
1	TV 20.4	TV 20.4	TV 20.4	TV 20.4
2	TV 20.4	TV 20.4	TV 20.4	TV 20.4
3	TV 20.4	TV 20.4	TV 20.4	TV 20.4
4	TV 20.4	TV 20.4	TV 20.4	TV 20.4
5	TV 20.4	TV 20.4	TV 20.4	TV 20.4
6	TV 20.4	TV 20.4	TV 20.4	TV 20.4
7	TV 20.4	TV 20.4	TV 20.4	
8	TV 20.4	TV 20.4		
9	TV 20.4			
Inner climbing unit	KSH 20 SH	KSH 20 SH	KSH 20 SH	KSH 20 SH
Foundation	FUA TYPE FS-156 / FUA 156S	FUA TYPE FS-156 / FUA 156S	FUA TYPE FS-156 / FUA 156S	FUA TYPE FS-156 / FUA 156S
Tower height [m]	55.5	51.0	46.5	42.0
Hook height (2-fall) [m]	56.5	52.0	47.5	43.0

Climbing radius 8033.20 cross

Climbing radius [m] for the balancing weights

8033.20	Jib length [m]						
	80	77.5	75	72.5	70	67.5	65
TV 20.4 = 2.98 t	34.3	36.0	45.7	52.5	50.5	53.4	51.6
Weight = 5.0 t	23.7	24.9	31.6	36.3	35.0	37.0	35.7
Weight = 10.0 t	-	-	-	-	-	-	-

Climbing radius [m] for the balancing weights

8033.20	Jib length [m]						
	62.5	60	57.5	55	52.5	50	47.5
TV 20.4 = 2.98 t	57.9	55.6	-	-	-	-	-
Weight = 5.0 t	40.1	38.5	42.3	42.8	40.9	43.0	42.2
Weight = 10.0 t	-	-	-	-	-	-	-

Climbing radius [m] for the balancing weights

8033.20	Jib length [m]						
	45	42.5	40	37.5	35	32.5	30
TV 20.4 = 2.98 t	-	-	-	-	-	-	-
Weight = 5.0 t	40.7	-	-	-	-	-	-
Weight = 10.0 t	-	24.0	22.9	23.1	23.8	25.2	24.3

WOLFFKRAN

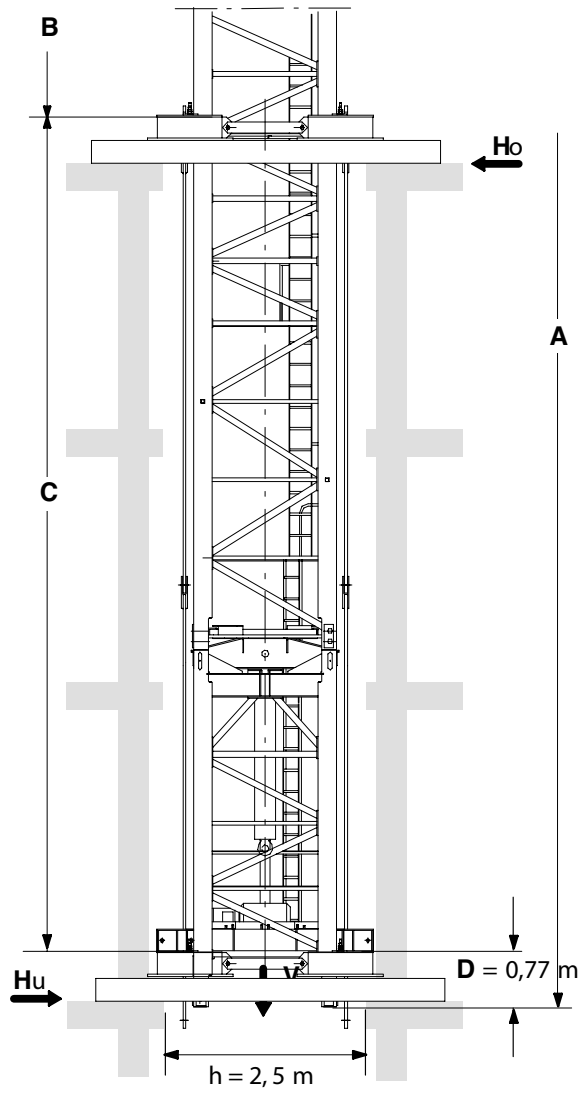

$$C_{\min} = 11,0 \text{ m}$$

$$C_{\max} = 14,0 \text{ m}$$

$$H_o = \frac{M}{C} + H$$

$$H_u = H_o - H$$

$$T = \frac{M_D}{2 \times b}$$

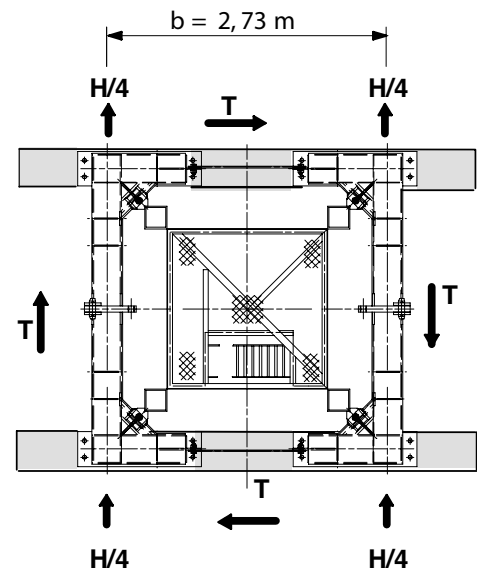

A	Tower height	C	Distance between guide frames
W	A-C-D		

In service clamping forces

In service clamping forces [kN] inside a building																
A [m]	55.5				51.0				46.5				42.0			
C [m]	11.0	12.0	13.0	14.0	11.0	12.0	13.0	14.0	11.0	12.0	13.0	14.0	11.0	12.0	13.0	14.0
V	1510				1481				1453				1425			
Ho	530	490	450	420	500	460	430	400	470	430	400	370	450	410	380	350
Hu	480	430	400	370	450	410	370	340	420	380	350	320	400	360	330	300
T	100				100				100				100			

Out of service clamping forces

Out of service clamping forces [kN] inside a building																
A [m]	55.5				51.0				46.5				42.0			
C [m]	11.0	12.0	13.0	14.0	11.0	12.0	13.0	14.0	11.0	12.0	13.0	14.0	11.0	12.0	13.0	14.0
V	1293				1265				1236				1208			
Ho	950	870	810	750	840	770	710	660	730	670	620	580	640	580	540	500
Hu	680	600	540	480	580	510	450	400	490	430	380	330	400	350	310	270
T	-				-				-				-			

8.2.2 Internal climbing unit KSH 23/ KSH E 23

	NOTICE
	<p>Lower clamping length for the internal climbing unit KSH E 23</p> <p>Subject to coordination with WOLFFKRAN, it is also possible to realize a clamping length of 10.0 to 15.5 m with a lower tower height. Contact WOLFFKRAN to discuss this issue.</p>

Tower combinations 8033 cross, on lower part of tower head section HT 23 with inner climbing unit

Item	Jib length 30 m - 80 m			
1	HT 23	HT 23	HT 23	HT 23
2	HT 23	HT 23	HT 23	HT 23
3	HT 23	HT 23	HT 23	HT 23
4	HT 23	HT 23	HT 23	HT 23
5	HT 23	HT 23	HT 23	HT 23
6	HT 23	HT 23	HT 23	HT 23
7	HT 23	HT 23	HT 23	HT 23
8	HT 23	HT 23	HT 23	HT 23
9	HT 23	HT 23	HT 23	HT 23
10	HT 23	HT 23	HT 23	
11	HT 23	HT 23		
12	HT 23			
Inner climbing frame	KSH E 23	KSH E 23	KSH E 23	KSH E 23
Foundation	FUA G 210	FUA G 210	FUA G 210	FUA G 210
Tower height [m]	70.5	66.0	61.5	57.0
Hook height [m] 2-fall	71.5	67.0	62.5	58.0

Climbing radius 8033.20 cross

Climbing radius [m] for the balancing weights

8033.20	Jib length [m]						
	80	77.5	75	72.5	70	67.5	65
HT 23 = 3.94 t	28.3	29.7	37.7	43.3	41.7	44.1	42.6
Weight = 5.0 t	23.7	24.9	31.6	36.3	35.0	37.0	35.7
Weight = 10.0 t	-	-	-	-	-	-	-

Climbing radius [m] for the balancing weights

8033.20	Jib length [m]						
	62.5	60	57.5	55	52.5	50	47.5
HT 23 = 3.94 t	47.8	45.9	50.5	51.0	-	-	-
Weight = 5.0 t	40.1	38.5	42.3	42.8	40.9	43.0	42.2
Weight = 10.0 t	-	-	-	-	-	-	-

Climbing radius [m] for the balancing weights

8033.20	Jib length [m]						
	45	42.5	40	37.5	35	32.5	30
HT 23 = 3.94 t	-	-	-	-	-	-	-
Weight = 5.0 t	40.7	-	-	-	-	-	-
Weight = 10.0 t	-	24.0	22.9	23.1	23.8	25.2	24.3

WOLFFKRAN

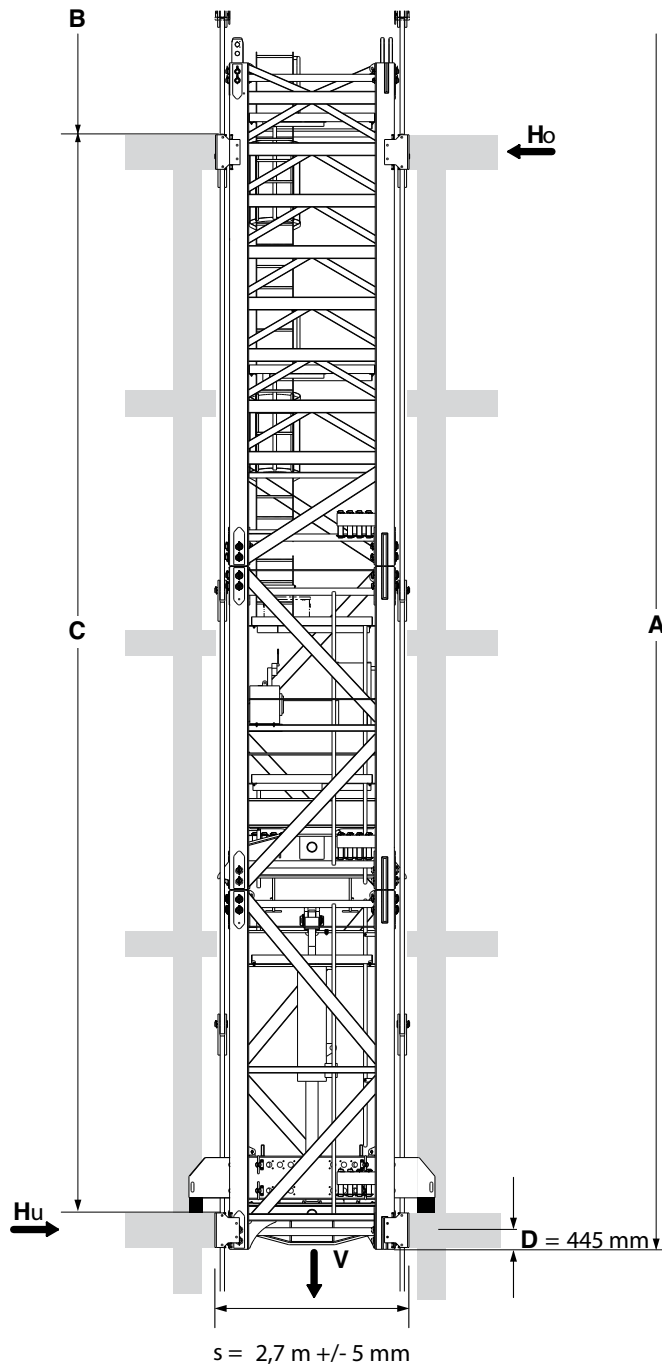

$$C_{\min} = 12,0 \text{ m}$$

$$C_{\max} = 15,5 \text{ m}$$

$$H_o = \frac{M}{C} + H$$

$$H_u = H_o - H$$

$$T = \frac{M_D}{2 \times b}$$

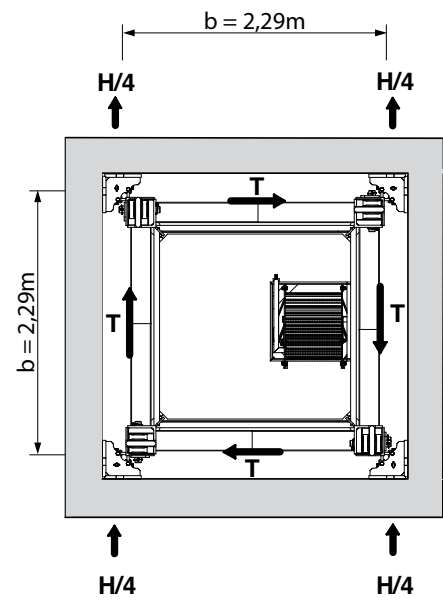

KSH E 23

A	= Tower height	C	= Distance between corner guides
W	= A-C-D		

WOLFFKRAN

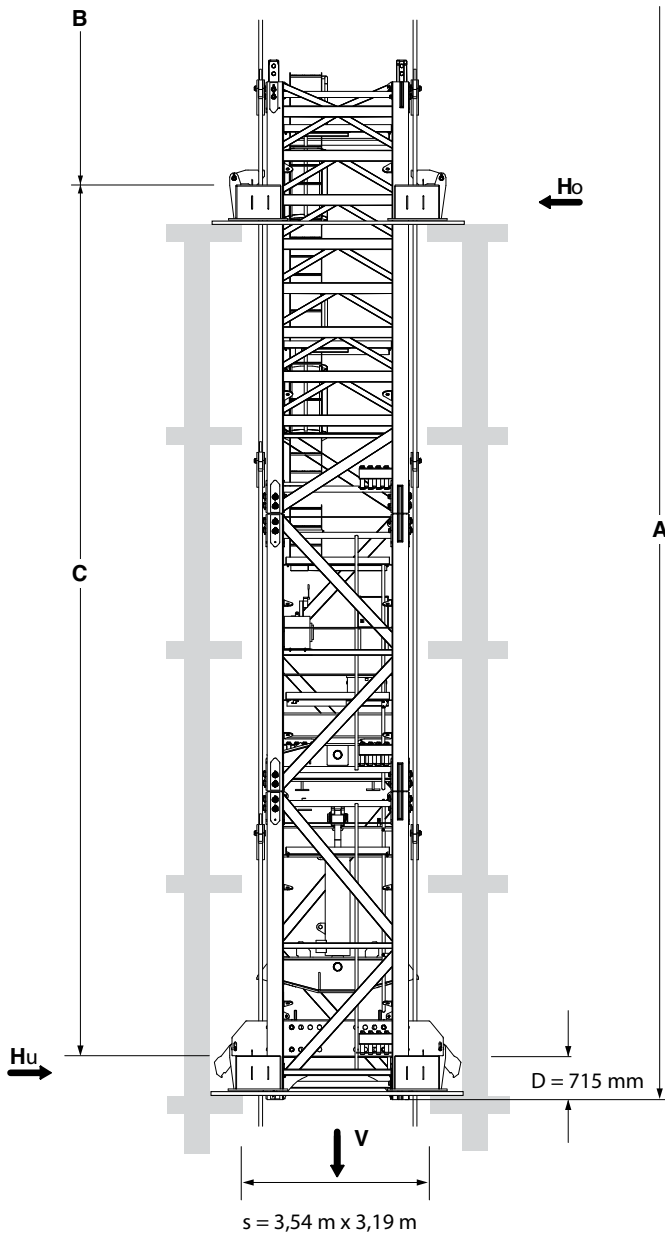

$$C_{\min} = 12,0 \text{ m}$$

$$C_{\max} = 15,5 \text{ m}$$

$$H_o = \frac{M}{C} + H$$

$$H_u = H_o - H$$

$$T = \frac{M_D}{2 \times b}$$

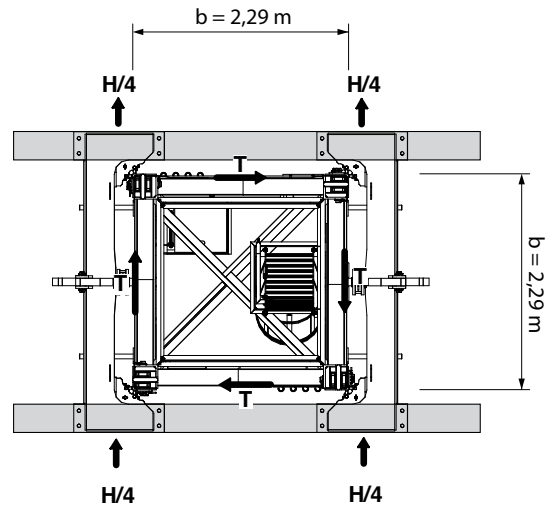

KSH 23

A	= Tower height	C	= Distance between climbing frames
W	= A-C-D		



Operational clamping forces

Operational clamping forces [kN] inside a building																				
A (m)	70.5					66.0					61.5					57.0				
C (m)	12.0	13.0	14.0	15.0	15.5	12.0	13.0	14.0	15.0	15.5	12.0	13.0	14.0	15.0	15.5	12.0	13.0	14.0	15.0	15.5
V (kN)	1936					1897					1857					1818				
Ho (kN)	580	540	500	470	450	550	510	470	440	430	520	480	440	410	400	490	450	420	390	380
Hu (kN)	510	470	430	400	380	480	440	410	370	360	450	420	380	350	340	430	390	360	330	320
T (kN)	110					110					110					110				

Non-operational clamping forces

Non-operational clamping forces [kN] inside a building																				
A (m)	70.5					66.0					61.5					57.0				
C (m)	12.0	13.0	14.0	15.0	15.5	12.0	13.0	14.0	15.0	15.5	12.0	13.0	14.0	15.0	15.5	12.0	13.0	14.0	15.0	15.5
V (kN)	1720					1680					1641					1601				
Ho (kN)	1330	1220	1140	1060	1030	1190	1100	1020	950	920	1070	990	920	850	830	950	880	810	760	740
Hu (kN)	980	880	790	720	680	860	770	690	620	590	750	670	600	540	510	650	570	510	460	430
T (kN)	-					-					-					-				

9 Arrangement of counterweight blocks

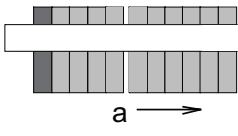
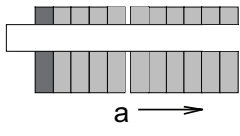
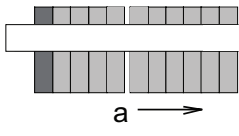
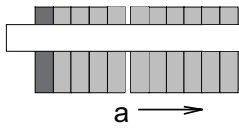
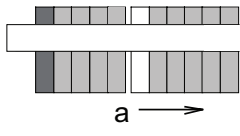
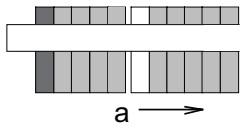
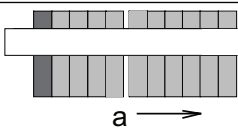
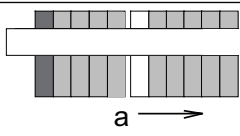
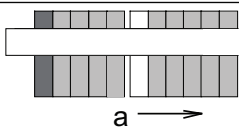
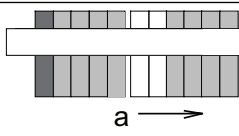
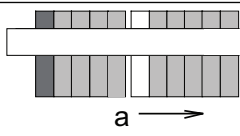
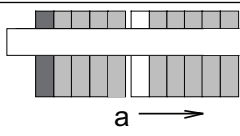
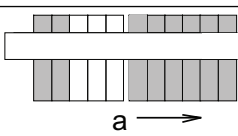
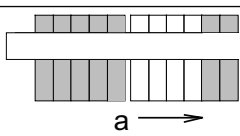
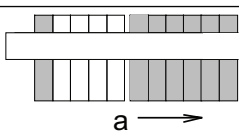
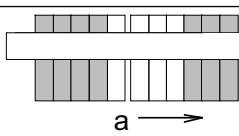
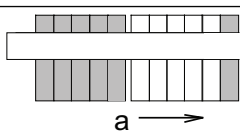
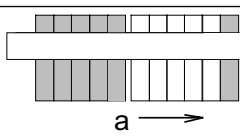
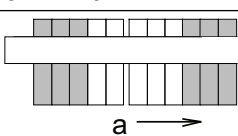
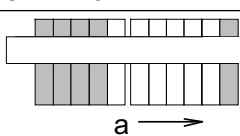
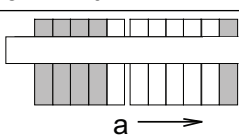
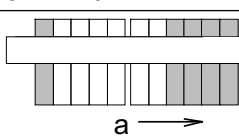
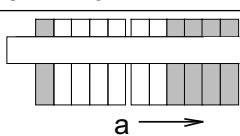
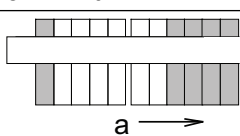
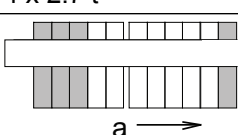
 Intermediate ballast 1 x 2.7 t		 Counterweight block, 1 x 2.7 t	
 No counterweight		L	Jib length [m]
a	To the tower	G	Total weight [t]
L = 80 m		L = 77.5 m	
11 x 2.7 t		11 x 2.7 t	
			
W = 29.7 t		W = 29.7 t	
L = 75 m		L = 72.5 m	
11 x 2.7 t		11 x 2.7 t	
			
W = 29.7 t		W = 29.7 t	
L = 70 m		L = 70 m	
11 x 2.7 t		10 x 2.7 t	
			
W = 29.7 t		W = 27.0 t	
L = 67.5 m		L = 65 m	
11 x 2.7 t		10 x 2.7 t	
			
W = 29.7 t		W = 27.0 t	
L = 62.5 m		L = 60 m	
10 x 2.7 t		9 x 2.7 t	
			
W = 27.0 t		W = 24.3 t	
L = 57.5 m		L = 57.5 m	
10 x 2.7 t		10 x 2.7 t	
			
W = 27.0 t		W = 27.0 t	
L = 55 m		L = 52.5 m	
8 x 2.7 t		7 x 2.7 t	
			
W = 21.6 t		W = 18.9 t	
L = 50 m		L = 47.5 m	
7 x 2.7 t		7 x 2.7 t	
			
W = 18.9 t		W = 18.9 t	
L = 45 m		L = 45 m	
6 x 2.7 t		6 x 2.7 t	
			
W = 16.2 t		W = 16.2 t	
L = 42.5 m		L = 40 m	
6 x 2.7 t		5 x 2.7 t	
			
W = 16.2 t		W = 13.5 t	
L = 37.5 m		L = 35 m	
5 x 2.7 t		5 x 2.7 t	
			
W = 13.5 t		W = 13.5 t	
L = 32.5 m		L = 32.5 m	
5 x 2.7 t		5 x 2.7 t	
			
W = 13.5 t		W = 13.5 t	
L = 30 m			
4 x 2.7 t			
			
W = 10.8 t			

WOLFFKRAN

■	Intermediate ballast 1 x 2.7 t	■	Counterweight block 1 x 2.7 t
□	No counterweight	L	Jib length [m]
a	To the tower	G	Total weight [t]

