

**Electric battery operated Carry-Deck Mobile Crane**  
**Max. Capacity - Kg. 16.000**



**360° radius boom rotation**



	
<b>On wheel</b>	
Outreach (mm)	Capacity (kg)
3.000	3.200
6.000	1.700
8.000	350



	
<b>Outrigger</b>	
Outreach (mm)	Capacity (kg)
3.000	9.000
6.000	4.300
8.000	1.300

## TECHNICAL DATA

**TRACTION:** by two DC 8 kW 72V reversible electric motor , controlled by inverter, variable speed controlled by electronic diagnostic, temperature control and alarm on brushes wear.

**TRANSMISSION:** differential axle with reduction gear between motor and wheels.

**BATTERY:** 72V 805Ah battery, battery meter on dashboard.

**BRAKES:** Hydraulic brake drum on the front and rear wheels. Parking hand brake mechanically operated.

**SUSPENSION:** oscillating rear axle.

**OUTRIGGERS:** four vertical horizontal separate and independent outriggers hydraulically operated and controlled by safety valves.

**WINCH:** hydraulic controlled by safety device.

**WHEELS:** Nr. 4 superelastic 300 R15

**BOOM:** boom fabricated from preformed and welded quality steel plate. Nr.4 telescoping sections: 1 fixed; 2 hydraulically telescoping. Fitted with nylon wear pads adjustable wear pads on the sides. Incorporated manual extension 360° slewing.

**BOOM CONTROL:** Proportional distributor controlled with joystick. Fitted with filter and safety valves. Motor driven pump 15 Kw 72V CC.

**LMI:** Electronic Load Moment Indicator. Display showing lifted load, max allowed load, tilting percentage, operative radius, angle, telescope and light indicators on the operative mode.

**TOTAL WEIGHT:** kg. 16.000 **MAX. CAPACITY:** kg. 16.000

**Options on request:** 4 Wheel Steering, swingaway Jib extension (0° -45° ), man bucket, remote control, enclosed cab, working light, fire extinguisher.

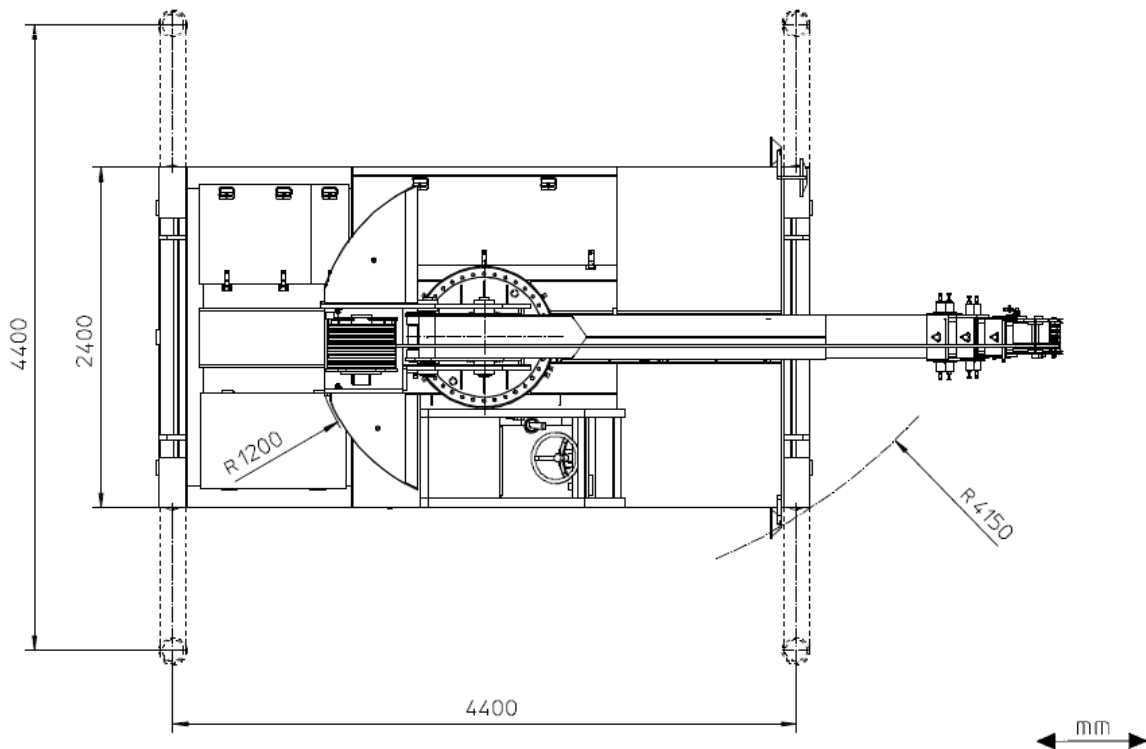
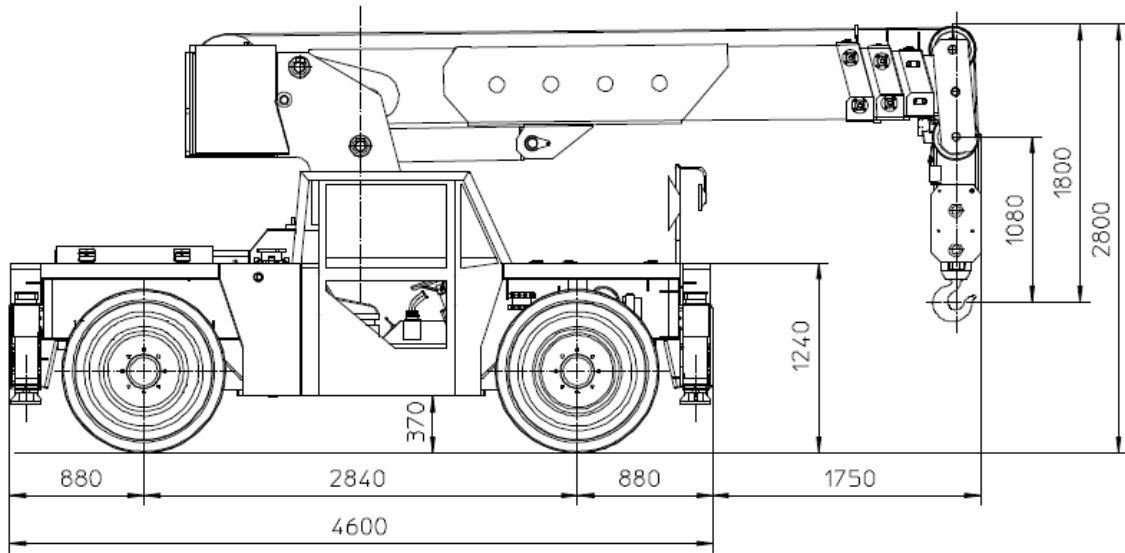

Data subject to be changed without any previous notice. Pictures may differ from technical description.

The crane complies with following

- standards:  
-2006/42/CE  
-UNIEN13000  
-I.S.P.E.S.I.

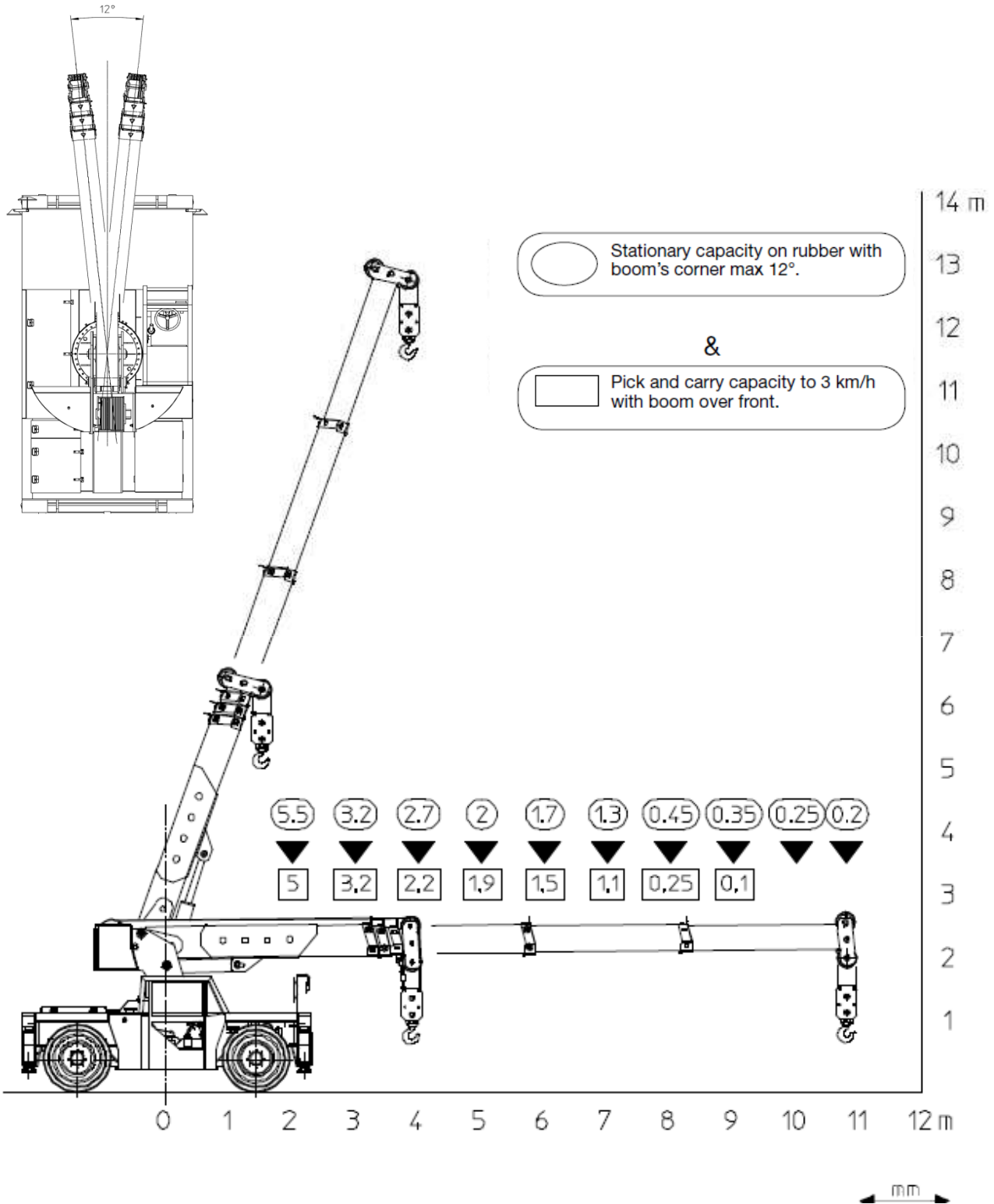

Data subject to be changed without any previous notice. Pictures may differ from technical description.

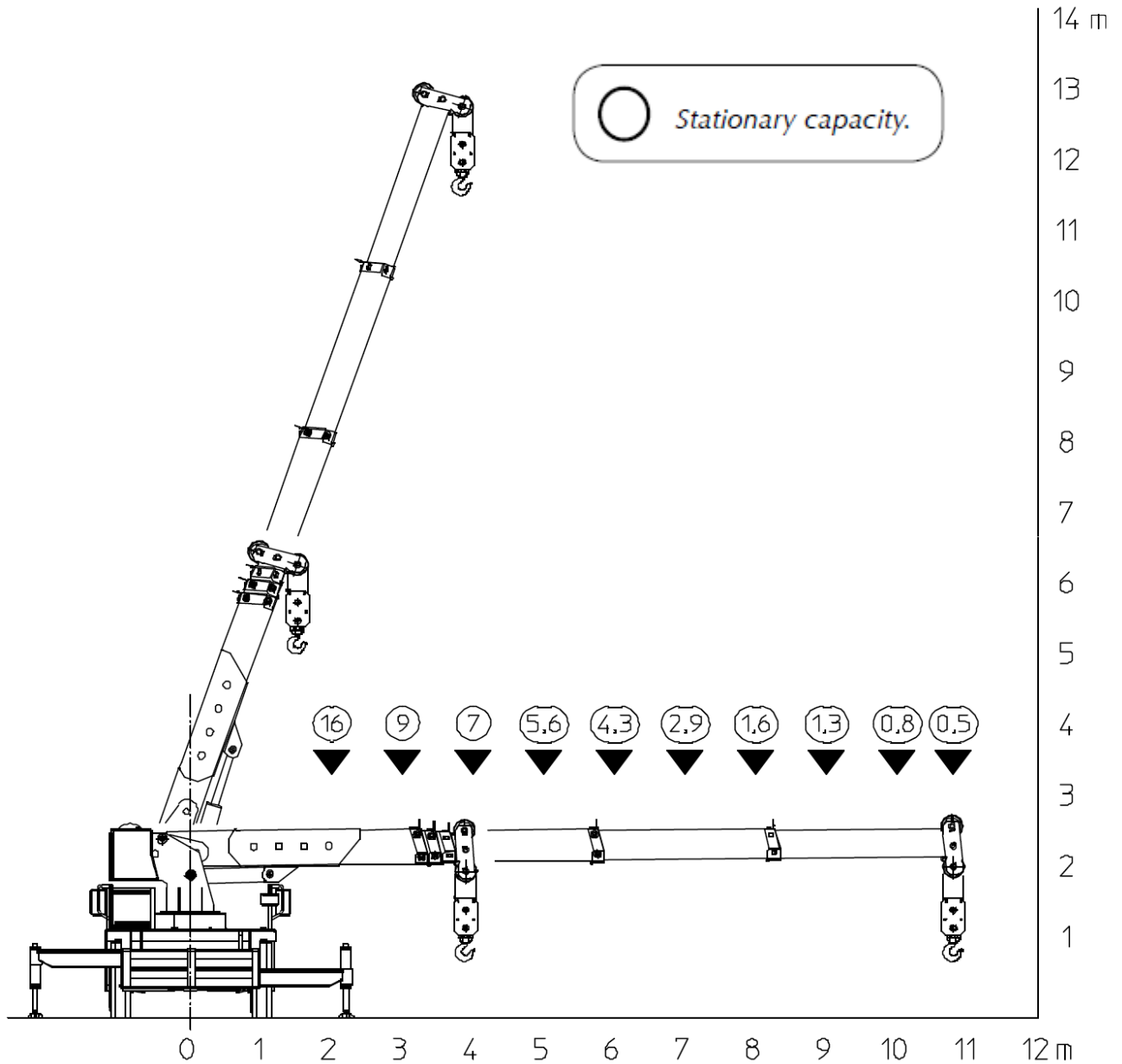

Data subject to be changed without any previous notice. Pictures may differ from technical description.

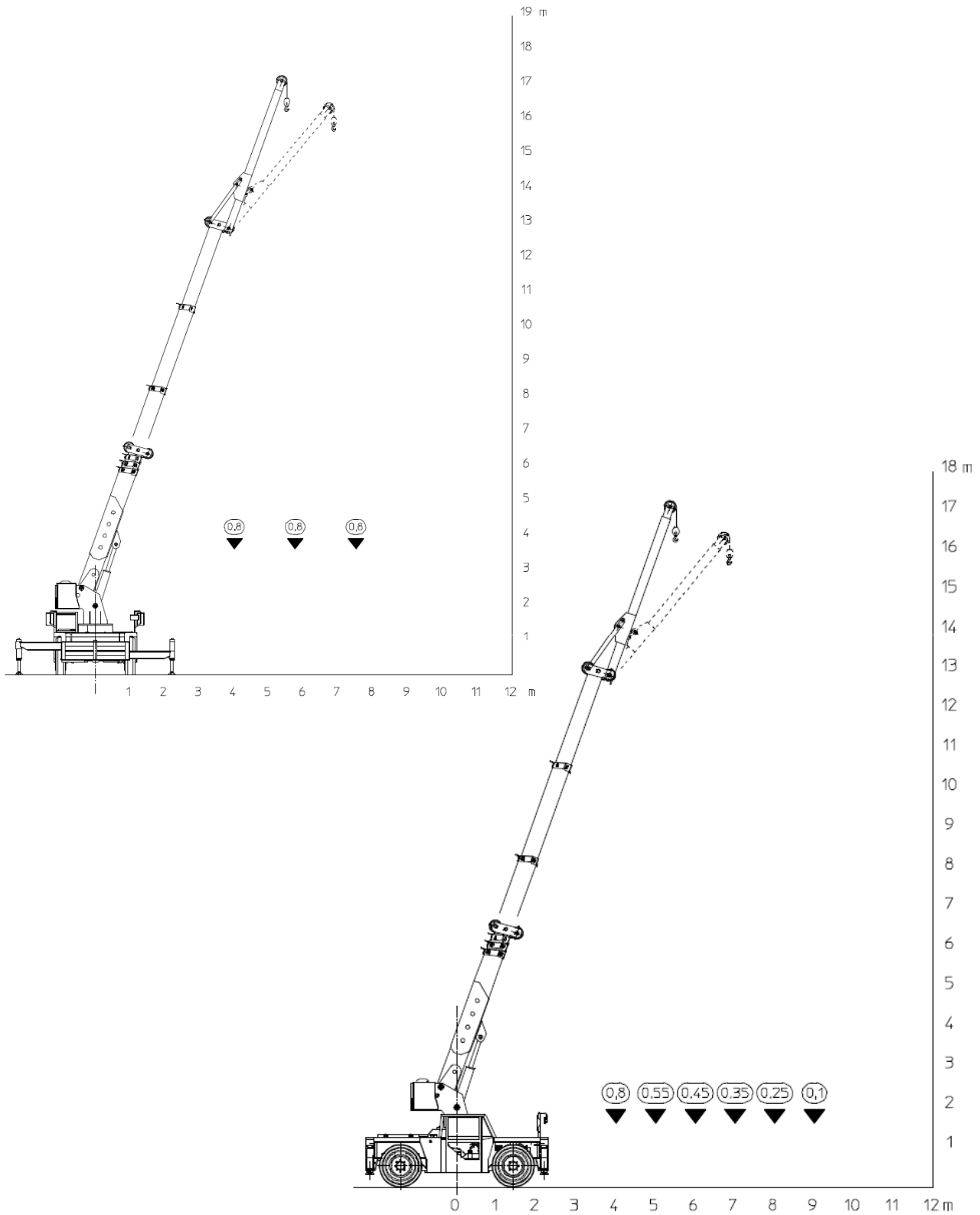

Data subject to be changed without any previous notice. Pictures may differ from technical description.

LIFTING CAPACITY MOD. 1725-36/SD-SE				
RADIUS (mt)	ON OUTRIGGERS	ON RUBBER		
	360°	STATIONARY CAPACITY OVER FRONT (max 12°)	STATIONARY CAPACITY 360°	PICK AND CARRY CAPACITY UP TO 3 km/h (boom over front)
1.50	---	---	---	---
2.00	16.000	5.500	3.900	5.000
2.50	12.000	4.000	3.000	4.000
3.00	9.000	3.200	2.000	3.200
3.50	8.000	3.000	1.500	2.500
4.00	7.000	2.700	1.200	2.200
4.50	6.300	2.200	950	2.000
5.00	5.600	2.000	700	1.900
5.50	4.800	1.800	650	1.700
6.00	4.300	1.700	500	1.500
6,50	3.600	1.500	450	1.300
7.00	2.900	1.300	340	1.100
7.50	2.000	500		300
8.00	1.600	450		250
8.50	1.400	400		150
9.00	1.300	350		100
9.50	1.100	300		
10.0	800	250		
10.5	500	200		

- Rated loads above do not exceed 80% of tipping loads on outriggers and 75% on rubber.  
 - Capacities above bold lines are based only on structural strenght of crane.  
 - Capacities and performances are for crane on firm, level surfaces.  
 - Pick and carry operation: boom has to be centered overfront, used in the shortest possible lenght, min radius, lowest angle, load close to the ground. Negotiating grades (max 10%) is only permitted WITHOUT LOAD and limited to short distance and time.  
 - When needed, outriggers must be fully extended.  
 - When lifting area is not clearly visible by crane's operator, the presence of a second man is mandatory for signaling.  
 - Never handle a load in the area above cab.

Data subject to be changed without any previous notice. Pictures may differ from technical description.