

ETC 35 SNT

Articulated / Telescopic Non-Insulated



Powerful Solution

The ETC 35 SNT is a non-insulated unit with 40' of working height and 390 degrees of non-continuous rotation. This aerial is an articulated, telescoping model providing the end-user a powerful solution to meet all personnel lifting needs in the field. Bucket mounted controls, variable speed controls and hydraulic bucket leveling are standard on this unit with a multitude of available options to suit each customized need.

ETI
A PALFINGER Company

Equipment Technology LLC is a full service solution provider of the highest quality design, manufacturing, and post sale service.

Equipment Technology LLC
 341 NW 122nd
 Oklahoma City, OK 73114
 Toll-Free: 1-888-748-3841
 Fax: 1-405-755-6829
 www.eti1.com

ETC 35 SNT

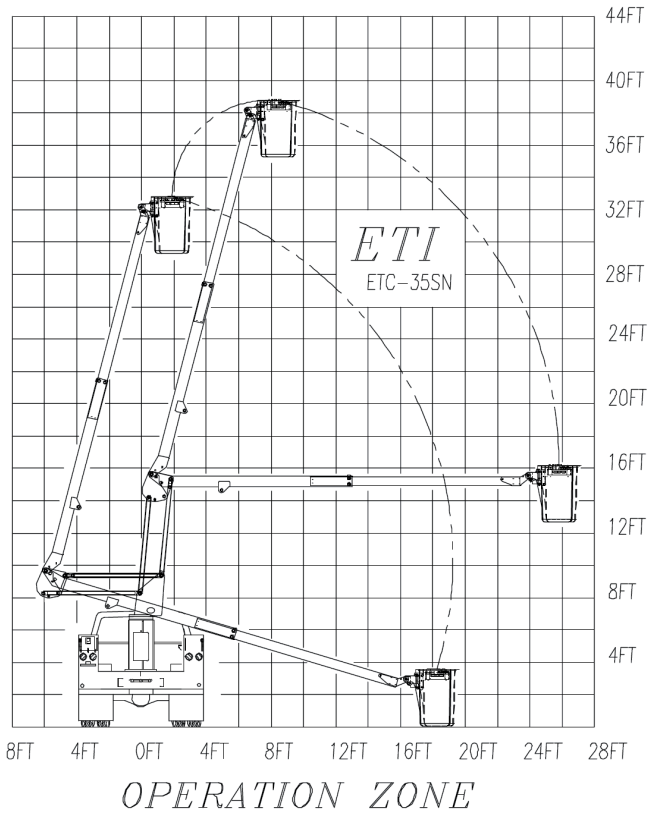

General Specifications*

Height to bottom of bucket	35 ft. - 0 in.
Working height	40 ft. - 0 in.
Side reach, End mount	26 ft. - 0 in.
Rotation	390° Non-continuous
Lower boom articulation	0 to 95 degrees
Upper boom travel	-17 to 75 degrees
Stow height	9 ft. - 9 in.
Rated bucket capacity	350 lbs.



Standard Features

- Bucket mounted controls
- Variable speed controls
- Hydraulic bucket leveling
- Emergency upper boom controlled descent

Minimum Vehicle Specifications

- GVWR 15,000 lbs.
- C.A. 60 in

Options

- Engine start/stop at bucket
- Emergency hydraulic power (12VDC)
- Air line to bucket
- Bridgeframe Hi-Cube body
- 90 degree bucket rotator

