

MANISCOPIC

MT 1840 H PRIVILEGE





- Maximum lifting height: 17.50 m
- Capacity: 4000 kg
- Maximum forward reach: 13.17 m
- Transmission hydrostatic
- Hydraulic stabilizers
- Frame levelling: $\pm 9^\circ$

 **MANITOU**

MT 1840 H **PRIVILEGE**

 **Lifting capacity**4000 kg
at 500 mm from forks heels.
Tipping load at maximum reach :
with stabilizers950 kg
Tear out force with bucket
to ISO 83138000 daN

 **Lifting height**17.50 m
Times : unladen / loaded (in s)
Lifting16.1/16.2
Lowering12.3/12
Extension boom.....27.5/33
Retraction boom26.4/25.7
Crowd.....4.3
Dump.....4

 **Tyres**.....440/80-24

 **Forks (mm)**
Length1200
Width x thickness125 X 50
Maximum distance between forks1040
Carriage rotation126°

 **Multidisc brakes - hydraulically assisted**

 **PERKINS Engine**
Type1104C.44 T
Capacity4 cylinders - 4400 cm³
Power :
(ISO/TR 14396) ...101 HP/74.5 kW at 2200 rpm
Maximum torque.....413 Nm at 1350 rpm
Direct Injection
Water Cooling

 **Transmission**hydrostatic
Electro-hydraulic reversing shift
3 speeds forward and reverse
Maximum travel speed (km/h).....25

 **Hydraulics**
Pumpgear type
Pressure/capacity270 bars/170 l/mn

 **Capacities**
Cooling system20 l.
Engine oil10.9 l.
Hydraulic oil.....121 l.
Fuel tank.....140 l.

 **Weight unladen**11685 kg
Overall width2.40 m
Overall height2.50 m
Turning radius (outside wheels)3.99 m
Overall Length6.27 m
Ground clearance0.44 m
Drawbar pull7665 daN

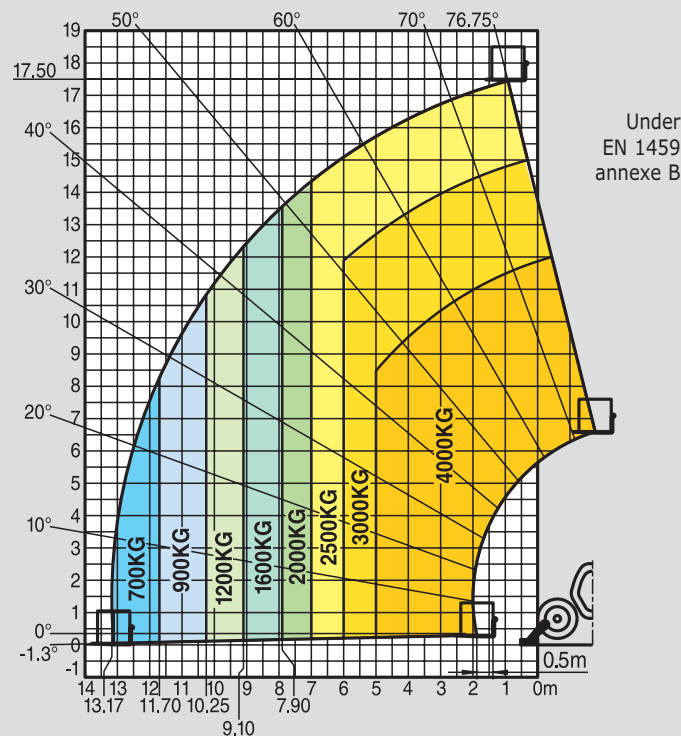

Under
EN 1459
annexe B

A	1200
B	3070
C	2044
C1	1929
D	6270
D1	6159
D2	4886
E	7473
F	1960
F1	1960
G	437
G1	420
G2	433
G3	302
H	9°
H1	9°
I	1160
J	892
K	1040
L	50
N	1908
O	125
P2	37°
P3	34°
R	3779
S	8780
T	4307
U1	2505
U2	2693
V	5592
V1	1285
V2	3998
W	2397
W1	3793
W2	1134
W3	2422
Y	12°
Z	114°

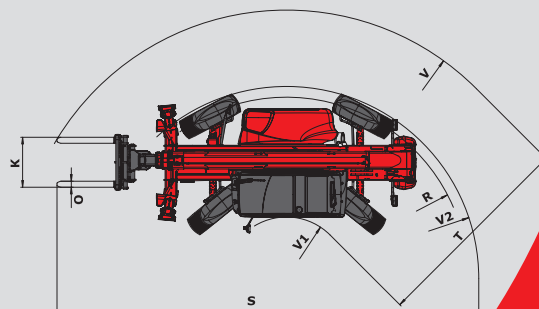
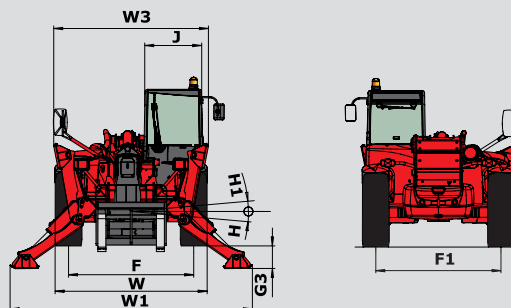
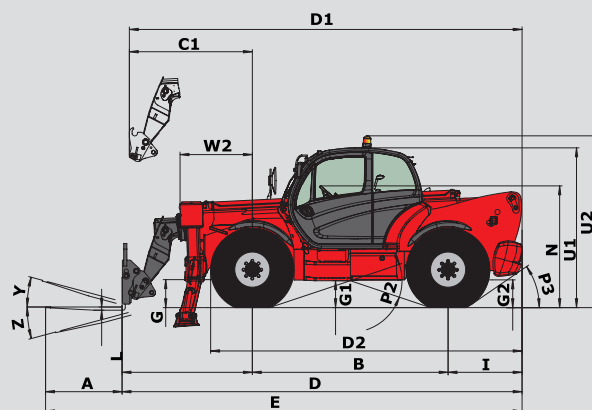

The specifications contained herein shall not bind the manufacturer and are subject to change without notice. This equipment described in this leaflet may be standard, optional, or unavailable, depending on the versions. For more details, contact your MANITOU dealer.



MANITOU BF SA

B.P. 249 - 44158 Ancenis Cedex - France
Tel. : 33 2 40 09 10 11 / Export Department Fax : 33 2 40 09 10 97
www.manitou.com

700402EN-B - 08/08

