

MANISCOPIC

MT 1745
H S L Turbo

- **Lift Capacity: 10,000 lb.**
- **Maximum Lift Height: 54 ft. 5 in.**
- **Maximum Forward Reach: 39 ft. 9 in.**
- **Perkins 101 HP Engine**
- **Hydrostatic Transmission**
- **Four Wheel Drive**
- **Three Steering Modes**
- **Hydraulic Stabilizers**
- **Frame Leveling**



Shown with optional enclosed cab
and windshield protection guard

 **MANITOU**

MT 1745HSLTurbo



Lift Capacity:

Maximum (24 in. load center).....10,000 lb.
Break out force on bucket teeth
with tilting ram (ISO 8313)18,500 lbf.



Lift Height:

Maximum lift height.....54 ft. 5 in.
Maximum forward reach.....39 ft. 9 in
Times: unladen / loaded (in sec)



Lifting15/16
Lowering.....10/9



Tires:

.....14.00 x 24 14 PR L2



Forks:

Length48 in.
Thickness/width2.25 in. x 4 in.
Carriage rotation124°



Brakes:

.....Hydraulic with oil immersed discs on front axle



Engine:

TypePerkins 1104C-44T Turbo Diesel
Displacement4 cyl. 268 cu. in.
Power.....101 HP/74.5 kw
Maximum Torque (@1400 rpm)304 ft.lb.
InjectionDirect
CoolingWater



Transmission:

TypeHydrostatic
Electro-hydraulic reversing shift
Speeds forward/reverse.....4/2
Maximum travel speed17 mph



Hydraulics:

Pump.....Dual Gear type
Flow3770 PSI - 54 gpm
Flow divider with priority to steering



Capacities:

Cooling system.....5.5 gal.
Engine oil3 gal.
Fuel tank36 gal.
Hydraulic fluid46.5 gal.



Specifications:

Weight (base unit)24,438 lb.
Turning radius (outside wheels).....174 in.
Overall height105 in.
Overall width97 in.
Overall length (without forks)234 in.
Ground clearance21 in.
Maximum drawbar pull.....17,000 lbf.

STANDARD EQUIPMENT:

- Full Time Power Steering
- 3 Modes of Steering with Wheel Alignment Indicator
- Adjustable Cushioned Ride Seat with Seat Belt
- Warning Lights for High Oil Temperatures
- Air Cleaner Service Indicator
- Hydraulic Oil Filter Restriction Gauge
- Road Lights
- Horn
- Alternator
- Backup Alarm
- Wet Disc Brakes
- Neutral Start Switch
- Instrument Cluster with Engine Oil Pressure, Water Temperature, Ammeter, Fuel Level Gauge
- Auxiliary Hydraulic Circuit
- Tow Pin
- Engine Hour Meter

OPTIONAL EQUIPMENT:

- A wide variety of attachments and options are available to meet the customer's individual applications

DIMENSIONS:

A48	K48
B121	L2.25
C72	N77
C ₁76	O4
D234	P ₂44°
D ₁238	P ₃52°
D ₂189	R166
E282	S354
F82	T158
F ₁82	U ₁105
G21.5	V225
G ₁21	V ₁67
G ₂21.5	V ₂174
G ₃11	W97
H7°	W ₁150
H ₁7°	W ₂41
I41	W ₃93
J37	Y12°
	Z112°

LOAD CAPACITY CHART

CALCULATED WITH 48" CARRIAGE AND FORKS
(OPTIONAL ATTACHMENTS CAN DERATE THIS CHART)

Capacities shown in pounds/feet are the maximum recommended load limits at the indicated extensions of the boom. Capacity ratings are based on a 48" homogeneous cube and are in accordance with ANSI/ASME B56.6 stability standards. Capacity reductions must be made for extended load centers and when used with various other attachments, contact MANITOU NORTH AMERICA, INC.

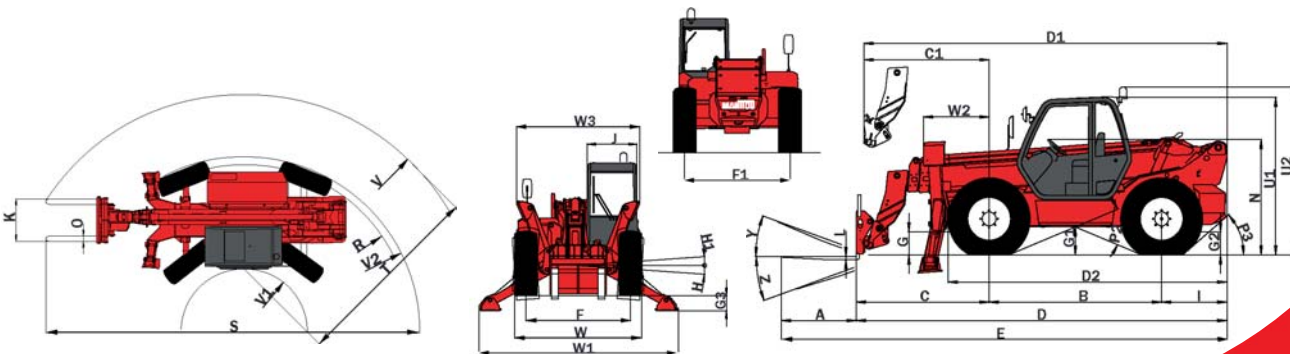
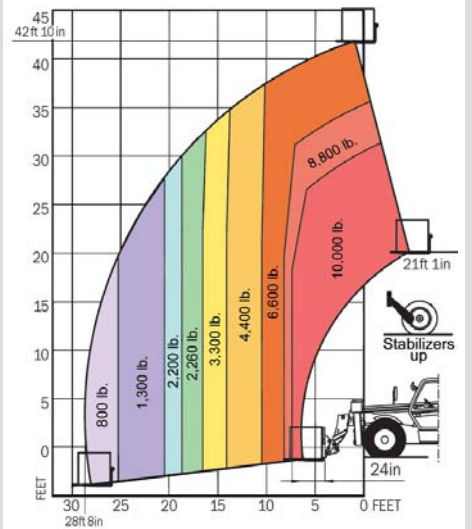
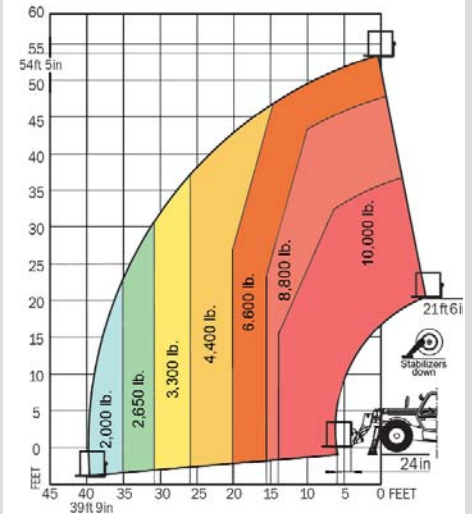

This publication in no way constitutes an offer and the company reserves the right to alter specification without prior notice. The MANITOU models presented in this brochure can be supplied complete with optional equipment attachments.

2/15/06 Printed in U.S.A.

MANITOU NORTH AMERICA, INC.
P.O. Box 21386
Waco, TX 76702-1386
Tel: 800-433-3304 Fax: 254-799-4433
www.manitou-na.com

