



# SCX400

## HYDRAULIC CRAWLER CRANE

# Specifications

## ASIAN ISSUE

This catalog is not applicable to European and North America areas.  
The machine shown may vary according to territory Specifications.  
Specifications are subject to change without notice.

Hitachi Sumitomo Heavy Industries Construction Cranes Co.,Ltd

**Head Office** : 12-14 Ueno 7-chome, Taito-ku,  
Tokyo 110-005, Japan  
**Telephone** : 81-3-3845-1387  
**Facsimile** : 81-3-3845-1394  
<http://www.hands-crane.com>

Printed in Japan. 0610Ⓚ02T.EA092

## HITACHI SUMITOMO

# SCX400

HYDRAULIC CRAWLER CRANE



<b>CRAWLER CRANE</b>	■Dimensions ■Specifications .....	3
	■Technical Description .....	4
	■Working Ranges .....	8
	■Rated Loads for Main Boom .....	9
	■Crane Boom Construction ■Crane Jib Construction	
	■Component Weights and Dimensions for Transport .....	10
<b>CLAMSHELL</b>	■Dimensions ■Specifications	
	■Working Ranges ■Clamshell Bucket .....	12
<b>DRAGLINE</b>	■Dimensions ■Specifications	
	■Working Ranges ■Dragline Bucket .....	13
<b>TECHNICAL DATA</b>	■Standard Equipment ■Front Attachments .....	14
	■Standard and Optional Equipment .....	15

Note: • All "ton" described in this catalog represent metric tons.  
• Specifications conform to the Safety Regulations for Cranes and Mobile Cranes in Japan.

## ■Dimensions

Unit: mm

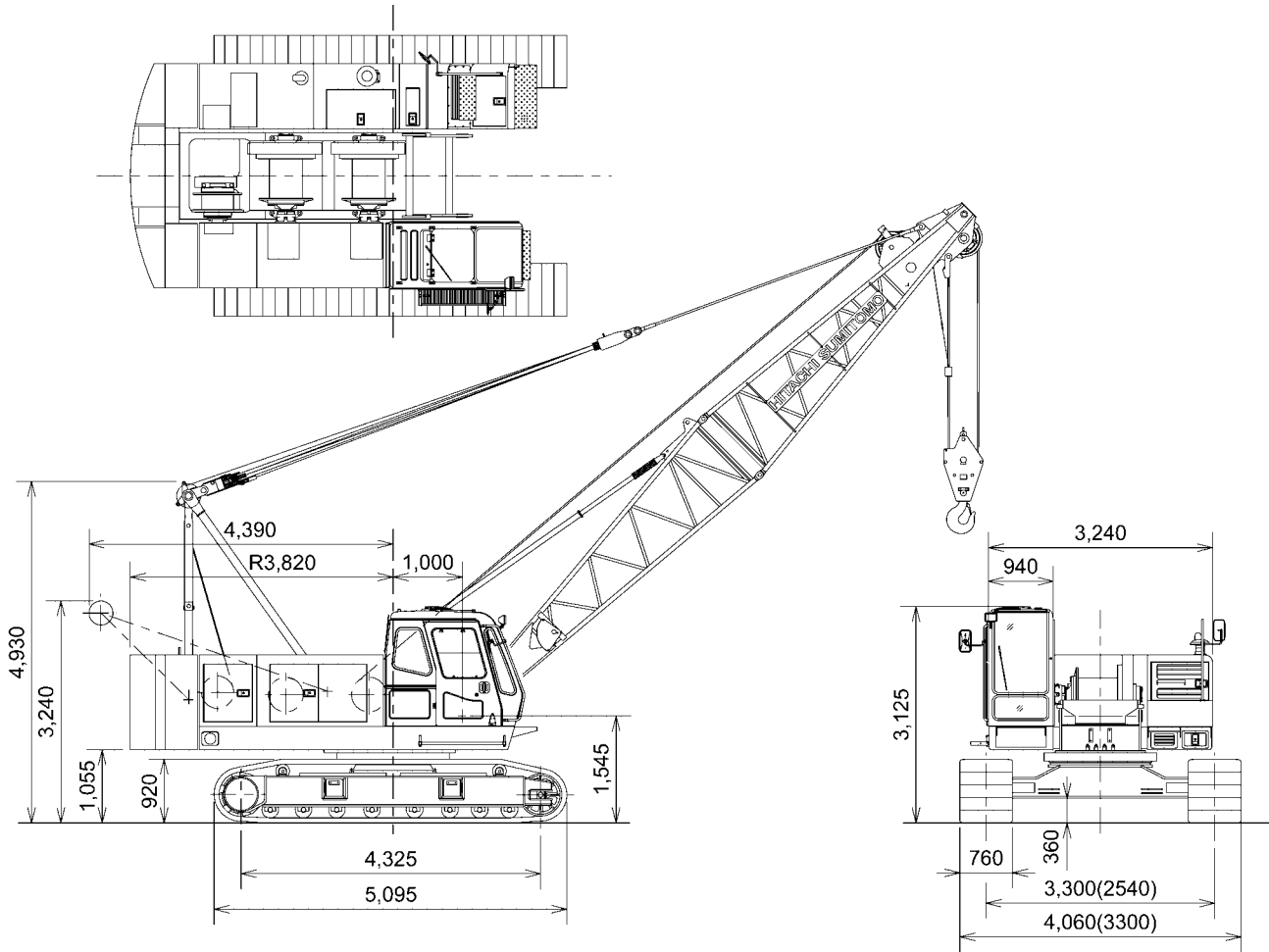

Notes: Dimensions shown in ( ) are with crawlers fully retracted.

## ■Specifications

Maximum Lifting load × Load radius	ton × m	40 × 3.7	
Basic boom length	m	10	
Maximum boom length	m	46	
Wire rope speed	Main/Aux. hoisting	m/min	*74/37
	Main/Aux. lowering	m/min	74/37
	Boom hoisting	m/min	*60
	Boom lowering	m/min	60
			Wire Rope Diameter 22 m
			Wire Rope Diameter 16 m
Swing speed	min <sup>-1</sup> (rpm)	3.7 (3.7)	
Travel speed	km/h	*2.0	
Gradeability	deg. (%) °	22 (40)	
Ground pressure	kPa (kgf/cm <sup>2</sup> )	63.8 (0.65)	
Engine model		ISUZU 4HK1X	
Engine rated power	kw/min <sup>-1</sup>	147/2 100	
Operating weight	ton	42.8 (with 10 m Boom + 40 t Hook)	

Notes : 1. Data is expressed in SI units, followed by conventional units in ( ).

2. \*Line speeds will vary with the load.



## Superstructure



### Engine

Model.....	Isuzu 4HK1X
Type .....	Water-cooled, 4-cycle, 6-cylinder, direct fuel injection type diesel engine
Rated power .....	147 kW (200 PS) at 2 100 min <sup>-1</sup> (2 100 rpm)
Maximum torque.....	688 N·m (70 kgf·m) at 1 500 min <sup>-1</sup> (1 500 rpm)
Piston displacement .....	5.19 L
Fuel tank capacity .....	300 L
Electric system .....	DC 24 V

#### Notes:

1. The engine meets Stage/Tier 3 of current smoke emission regulations in Europe, America and Japan.
2. A 147 kW engine horsepower shown above is defined under a current international engine horsepower indication formula which includes necessary horsepower for engine alternator drive but excludes engine fan drive.



### Main and Auxiliary Hoist Mechanism

- The SCX400 is equipped with dual hoist mechanisms, each consisting of independent main and auxiliary hoist drums driven by a hydraulic motor.
- Hoisting and lowering the load is achieved by forward/reverse rotation of the hydraulic motor.
- Power lowering is carried out with a hydraulic brake.
- Hoisting and lowering can be carried out at two speeds-fast and slow-to suit job requirements.
- Each drum is fitted with a friction band-type brake. This allows free fall (rapid lowering) of the bucket.
- Main and auxiliary hoist drums are each fitted with a pawl-type drum lock to positively hold the load in the air.
- The drum brake is an external contracting friction band-type using durable non-asbestos lining.
- The brake is controlled by the hydraulic servo system to reduce control force. With the hoist lever in neutral, auto braking or foot braking can be selected.



### Boom Hoist Mechanism

- Boom hoisting/lowering is done by forward/reverse rotation of a hydraulic motor. Boom lowering is made by power lowering through a hydraulic brake.
- Both hydraulic brake and spring-set/hydraulic-released multiplate disc type brake offer positive stopping of the boom. When the boom is hoisted or lowered, brakes are automatically released.
- Boom hoist drum is fitted with a pawl-type drum lock.



### Swing Mechanism

- Independent operation separated from other functions.
- Driven by a hydraulic motor through reduction gear. Swing speeds are freely controllable from zero to maximum speed with a single lever.

#### Swing Brake

The disc-type swing brake can be hydraulically applied by the brake switch on the swing lever.

#### Swing Lock

Manual mechanical-lock with a rod tip engaged in the holder of the track frame for transportation.

#### Swing Circle

Single-row shear-type ball bearing with heat-treated internal gear.



### Revolving Frame

All welded steel construction, stress-relieved, precision-machined for rigidity and strength.

#### Gantry

Lowerable for transportation.

#### Counterweight

Total weight:	12 500 kg
Consisting of 2 sections: One	5 200 kg
One	7 300 kg



## Boom

### Tubular Chord Crane Boom

1 150 mm wide by 1 150 mm deep at connection, lattice construction using high-tensile steel tubular chords.

- Basic boom ..... Total length 10.0 m, 2-piece construction; upper section 4.5 m and lower section 5.5 m.
- Boom point ..... Offset boom point, 3 sheaves (462 mm PCD) mounted on anti-friction bearings on boom top.
- Boom inserts ..... 3.0 m and 6.0 m long available.
- Connection type ..... Pin-connected.
- Boom backstop ..... Dual-rail, telescopic tubular construction with spring damper.
- Boom hoist bridle ..... Serves as connection between pendants and boom hoist wire rope reeving, equipped with 6 sheaves (340 mm PCD) for 12-part boom hoist wire rope reeving.

### Crane Jib

550 mm wide by 480 mm deep at connection, lattice construction using high-tensile steel tubular chords

- Basic jib ..... Total length 6.0 m, 2-piece construction; upper section 3.0 m and lower section 3.0 m.
- Jib point ..... 1 sheave (462 mm PCD) mounted on antifriction bearings on jib top.
- Jib insert ..... 3.0 m long available.
- Connection type ..... Pin-connected.
- Auxiliary jib ..... Optional. Attachable to the main boom top to hoist the light load quickly with a single rope.

**Note** : Boom insert, crane jib, or auxiliary jib can be attached to the basic boom when needed. However, both crane jib and auxiliary jib cannot be attached simultaneously to the boom.



## Operator's Cab

All-weather, well-ventilated, roomy operator's cab with good visibility. The independent cab is insulated against noise and vibration.



## HYDRAULIC SYSTEM

- 2 variable displacement piston pumps allow both independent and combined operations of all functions.
- Variable displacement piston pumps control working speeds, and make effective use of engine horsepower.

	Pump-1	Pump-2
<b>Type of pump</b>	Variable displacement	
<b>Pressure setting</b>	29.4 MPa (300 kgf/cm <sup>2</sup> )	29.4 MPa (300 kgf/cm <sup>2</sup> )
<b>Max. oil flow*</b>	222 L/min	222 L/min

	Pump-3	Pump-4
<b>Type of pump</b>	Variable displacement	Gear
<b>Pressure setting</b>	23.0 MPa (235 kgf/cm <sup>2</sup> )	4.9 MPa (50 kgf/cm <sup>2</sup> )
<b>Max. oil flow*</b>	130 L/min	32 L/min

\*with non-loaded condition

### Main and Auxiliary Hoist Motors

Axial piston motors with counterbalance valves.

### Boom Hoist Motor

Axial piston motor with counterbalance valve.

### Swing Motor

Axial piston motor.

### Travel Motors

Axial piston motors with brake valve and spring-set/hydraulic-released multiplate disc brake

### Relief and Brake Valves

- Each hydraulic circuit incorporates large-capacity relief valves to protect circuit from overload and shock load.
- Counterbalance valves, provided for hoist motor, compensate load lowering and prevent accidental load drop if hydraulic power is suddenly reduced.
- Brake valves (consisting of relief valve and counterbalance valve) are provided for travel circuit.

### Pressure Settings

Main Circuit

- Main relief valves
  - Hoist (main and aux.) ..... 29.4 MPa (300 kgf/cm<sup>2</sup>)
  - Swing ..... 23.0 MPa (235 kgf/cm<sup>2</sup>)
- Overload relief valves
  - Hoist (main and aux.) circuits ..... 31.4 MPa (320 kgf/cm<sup>2</sup>)
  - Boom hoist circuit ..... 30.4 MPa (310 kgf/cm<sup>2</sup>)
  - Travel circuit ..... 32.3 MPa (330 kgf/cm<sup>2</sup>)

Pilot Circuit

- Main relief valve
  - ..... 4.9 MPa (50 kgf/cm<sup>2</sup>)

### Line Filters

High-filtration 10 μm full-flow filter element is incorporated in the return line. Pilot filter and suction filter are provided in each circuit.

## Undercarriage

### Traction mechanism

- Each track is driven by an axial piston motor through reduction gear. This mechanism allows counter-rotation of tracks for maneuverability in close quarters.
- When the lever is in neutral position, both hydraulic brake and spring-set/hydraulic-released multiplate disc brake are automatically applied for stopping.

### Track Frame

All-welded, stress-relieved, box-section construction

### Side Frames

Side frames of all-welded construction can be retracted for transportation.

### Side Frame Extending/ Retracting Device

- Side frames are extended and retracted with a hydraulic cylinder located inside the track frame. Hydraulic power source for a hydraulic cylinder is separated from other systems to allow combined operation of travel and side frame.
- The side frames are extended and retracted quickly without need for piping

### Track Shoes

Heat-treated alloy steel castings with induction-hardened roller path and driving lugs.

No. of upper rollers (each side).....	2
No. of lower rollers (each side).....	8
No. of track shoes (each side) .....	59
Shoe width.....	760 mm

## Controls

### Boom, Main and Auxiliary Hoist, Swing and Travel

Remote controlled hydraulic servo. Working speed can be precisely controlled according to lever stroke.

#### ● Electric Accelerator Grip

Engine power can be controlled according to job needs by electric finger-touch grip atop the swing lever, accelerator lever and accelerator pedal.

#### ● Monitor Telling Machine Conditions

With the monitor, the operator can check, at a glance, engine oil pressure, water temperature and fuel level, as well as levels of hydraulic oil, engine oil and coolant. The red light turns on and/or the buzzer sounds in the event of an abnormality.

## Safety Device

### Boom Angle Indicator

Mechanical-type boom angle indicator is provided at boom foot.

### Counterbalance Valves (Brake Valves)

Counterbalance valves are each incorporated in travel motors, boom hoist motor, and main and auxiliary hoist motors. If the hydraulic line is broken, this valve is automatically actuated to prevent motor rotation.

### Spring-Set/Hydraulic-Released Multiplate Disc Type Travel Brakes

### Swing Lock and Swing Parking Brake

### Drum Locks (Electric Type)

A pawl-type drum locks, provided at main drum, auxiliary drum and boom drum, are automatically applied when the engine key is set to OFF or ACC position.

### Lever Locks

Main and auxiliary hoist levers, boom hoist lever, and travel levers are each fitted with lock mechanisms to prevent mishandling.

### Devices for Crane Operation

#### ● Moment Limiter

On the moment limiter, analog displays and pictorial load indications are functionally arranged for easy reading.

#### ● Hook Overhoist Prevention Device

When the hook reaches its hoist limit, the bell sounds and the auto-stop automatically actuates at the same time.

#### ● Boom Overhoist Prevention Device

When the boom reaches its angle limit, the buzzer alarm sounds and boom hoisting automatically stops at the same time. The telescopic-type boom backstop is also provided.

#### ● Secondary Boom Overhoist Prevention Device

In addition to the hook overhoist prevention device and boom overhoist prevention device, the secondary boom overhoist prevention device is provided.

#### ● Pilot Control Shut-off Lever

The pilot control shut-off lever shuts out the hydraulic pilot pressure to pilot control valves. With the pilot control shut-off lever in the LOCK position, the machine will not operate even if the lever is accidentally shifted.

#### ● Reliable mechanism

The related movements stop automatically if an electric wire is broken.



## Service Refill Capacities

	Liter
Fuel tank .....	300
Engine coolant .....	27
Engine oil .....	23
Boom hoist reduction device .....	9.5
Winch hoist reduction device .....	12.5×2
Swing reduction device .....	8
Travel final device .....	8.5×2
Hydraulic system, including tank capacity.....	305
Hydraulic tank .....	230

■ Working Ranges

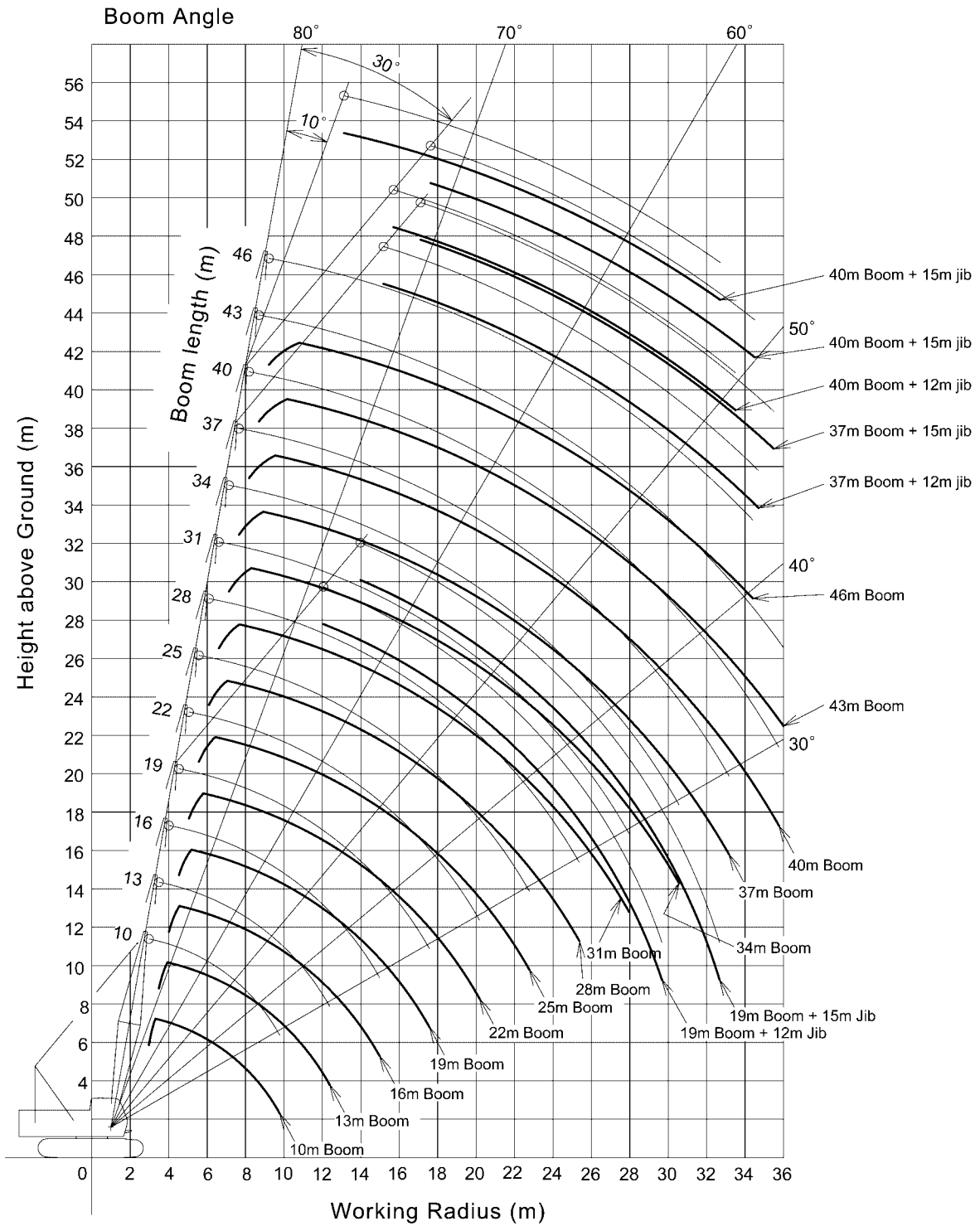

■ Correlation between the number of rope falls, maximum rated loads, hook weight are shown in the table below.

Hook capacity (ton)	Hook weight (ton)	Maximum rated loads (t)					
		6 Rope reevings	5 Rope reevings	4 Rope reevings	3 Rope reevings	2 Rope reevings	1 Rope reeving
40.0	0.41	40.0	32.5	26.0	19.5	13.0	—
15.0	0.32	—	—	—	15.0	13.0	—
6.5	0.18	—	—	—	—	—	6.5



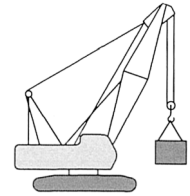

Unit: t

### Rated Loads for Main Boom

Working radius (m)	Boom length (m)						
	10	13	16	19	22	25	28
3.5	40.00						
3.7	40.00	40.00					
4.0	35.45	35.40	4.2×32.65				
4.5	29.45	29.35	29.30	4.7×27.35			
5.0	25.15	25.05	25.00	24.95	5.3×22.85		
5.5	21.90	21.80	21.75	21.70	21.65	5.8×20.00	
6.0	19.40	19.30	19.20	19.15	19.10	19.05	6.4×17.35
7.0	15.70	15.65	15.55	15.50	15.45	15.35	15.30
8.0	13.20	13.10	13.00	12.95	12.90	12.80	12.75
9.0	11.35	11.25	11.10	11.05	11.00	10.95	10.85
10.0	9.7×10.30	9.80	9.70	9.65	9.55	9.50	9.45
12.0		7.80	7.65	7.60	7.55	7.45	7.40
14.0		12.3×7.55	6.30	6.20	6.15	6.05	6.00
16.0			14.9×5.80	5.25	5.15	5.05	5.00
18.0				17.5×4.65	4.40	4.30	4.20
20.0					3.80	3.70	3.65
22.0					20.1×3.80	3.25	3.15
24.0						22.7×3.10	2.75
25.3							2.55

Working radius (m)	Boom length (m)					
	31	34	37	40	43	46
6.9	15.55					
7.0	15.25	7.5×13.75				
8.0	12.65	12.60	11.95	8.6×10.40		
9.0	10.80	10.70	10.70	10.25	9.1×9.05	9.7×7.80
10.0	9.35	9.25	9.25	9.15	8.80	7.75
12.0	7.30	7.20	7.20	7.10	7.00	6.90
14.0	5.90	5.80	5.80	5.70	5.60	5.50
16.0	4.90	4.80	4.75	4.70	4.60	4.50
18.0	4.15	4.05	4.00	3.90	3.85	3.75
20.0	3.55	3.45	3.40	3.30	3.20	3.15
22.0	3.05	2.95	2.90	2.85	2.75	2.65
24.0	2.70	2.55	2.55	2.45	2.35	2.20
26.0	2.35	2.25	2.20	2.10	1.95	1.85
28.0	27.9×2.10	1.95	1.90	1.75	1.65	1.55
30.0		1.70	1.65	1.50	1.40	1.25
32.0		30.5×1.65	1.40	1.25	1.15	1.05
34.0			33.1×1.30	1.05	0.95	0.85
36.0				35.7×0.90	0.80	34.5×0.80

- Notes:
1. The rated loads shown do not exceed 78% of tipping load with the machine on firm level ground, and are not less than 1.15 times over-front stability stipulated by the mobile crane construction standards.
  2. To calculate the maximum load that can actually be lifted, deduct weight of all lifting accessories, such as main and aux. hooks, from figures shown above.
  3. Working radius is the horizontal distance from the swing center to the center of gravity of a lifted load.
  4. The counterweight is 12.5 ton.
  5. Be sure to fully extend the side frames before operating the machine.
  6. Rated line pull is 6 500 kgf when 22 mm dia. wire rope is used.
  7. Figures described as ○×○ in the tables indicate working radius (m) × rated load (ton).







## ■Dimensions

Unit: mm

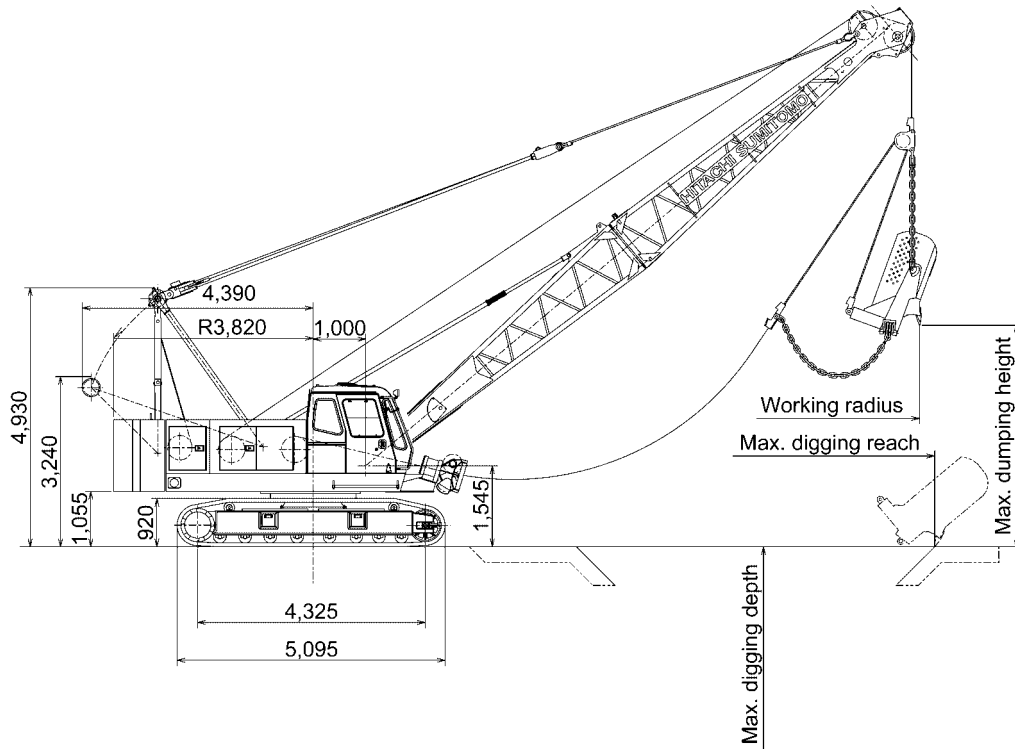

## ■Specifications

Bucket capacity	m <sup>3</sup>	1.15	
Boom length	m	13 to 22	
Suspend line speeds	m/min	*74/37	Rope 22 mm dia.
Drag line speeds	m/min	*74/37	Rope 22 mm dia.
Boom hoist/lower line speed	m/min	*60	Rope 16 mm dia.
Travel speeds	km/h	2.0	
Swing seeds	min <sup>-1</sup> (rpm)	3.7 (3.7)	
Ground pressure	kPa (kgf/cm <sup>2</sup> )	66.9 (0.68)	
Operating weight	ton	44.9 (13 m boom + 1.15 m <sup>3</sup> bucket)	
Engine	kW/min <sup>-1</sup> (PS/rpm)	4HK1X/ Isuzu 147/2 100 (200/2 100)	

## ■Dragline Bucket (Reference data)

Capacity (m <sup>3</sup> )	Weight (ton)	Use
1.15	1.28	Medium service

- Notes: 1. Data is expressed in SI units, followed by conventional units in ( ).  
 2. Other specifications, not shown, are similar to those for the crane.  
 3. \*Line speeds will vary with the load.

## ■Working Ranges

Boom length	m	13			16			19		22
Boom angle	degree	30	40	50	30	40	50	40	50	50
Working radius	m	12.6	11.3	9.8	15.2	13.6	11.7	15.9	13.6	15.5
Rated load	ton	4.65	5.40	6.00	3.40	4.00	5.00	3.00	3.90	3.05
Max. digging reach	m	16.1	15.7	14.9	19.4	18.8	17.8	22.0	20.8	23.6
Max. digging depth	m	8.4	8.1	7.5	10.9	10.5	9.7	12.8	11.9	14.0
Boom dumping height (1.2 m <sup>3</sup> bucket)	m	2.1	4.0	5.6	3.6	5.9	7.9	7.8	10.2	12.5

- Notes: 1. The size of the bucket has to be determined according to local conditions.  
 2. The rated loads shown are upper limits determined by the following equation. Please select a bucket in such a manner that its rated load does not exceed the rated load shown above, according to kinds of the loads handled.  
 Rated load = Bucket capacity (m<sup>3</sup>) × Specific gravity of load (ton/m<sup>3</sup>) + Bucket weight (ton)  
 Be careful that brake will be overheated if the bucket is too heavy even within the rated loads.  
 3. Working radius is the horizontal distance from the swing center to the center of gravity of lifted load.  
 4. Maximum digging reach/depth may vary considerable depending on digging condition and the skill of the operator.  
 5. The counterweight is 12.5 ton.  
 6. Be sure to fully extend the crawlers before operating the machine.

## ■ STANDARD EQUIPMENT

### BASIC MACHINE

#### Undercarriage

- Crawler-type undercarriage (with 760 mm shoes)
- Side frame extend cylinder (1 pc)

#### Superstructure

- Front lights (2 pcs)
- Rearview mirrors (left and right)
- Hoist drum check mirror
- Centralized lubrication system (for gantry and swing circle)
- Electric refuel device
- Under-cover (at superstructure bottom)
- Cab entrance steps
- Fine speed controller
- 12.5 ton counterweight
- Standard tool kit

#### Cab

- Intermittent-wipers (front and roof window)
- Washers (front and roof window)
- Rolled sunshade (roof window)
- Sunvisor
- Floor mat
- Room light
- Cigarette lighter
- Ashtray
- Auto-tuning clock radio (AM/FM)
- Brake mode selector switch (interlocked)
- Electric tilt-type right side stand

#### Safety Devices

- Swing lock
- Drum pawl lock (main and auxiliary hoist, and boom hoist)
- Swing alarm
- Fail safe brake system
- Pilot control shut-off lever
- Before-work check monitor

### FRONT ATTACHMENTS

#### Crane

- 10 m basic boom (lower 5.5 m, upper 4.5 m)
- Boom back stop
- Boom angle indicator
- 40 ton hook
- Main hoist rope ( $\phi 22$  mm  $\times$  145 m)
- Boom hoist rope ( $\phi 16$  mm  $\times$  135 m)
- Moment limiter
- Overhoist prevention devices (main hook, boom hoist, secondary)

#### Clamshell

- 10 m basic boom (lower 5.5 m, upper 4.5 m)
  - Boom back stop
  - Boom angle indicator
  - Open/close and suspend rope disengagement prevention device (for tubular chord boom)
  - Open/close rope ( $\phi 22$  mm  $\times$  67 m)\*
  - Suspend rope ( $\phi 22$  mm  $\times$  60 m)\*
  - Hydraulic tagline with  $\phi 10$  mm  $\times$  45 m rope
  - Boom hoist rope ( $\phi 16$  mm  $\times$  135 m)
- \* Open/close and suspend ropes are determined based on 19 m boom length and 12 m digging depth.

#### Dragline

- 13 m angle chord boom [Lower 6.5 m, upper 6.5 m and wide-angle sheaves (with 1 boom-point sheave) ]
- Boom back stop
- Boom angle indicator
- Hoist rope ( $\phi 22$  mm  $\times$  50 m)
- Drag rope ( $\phi 22$  mm  $\times$  60 m)
- Boom hoist rope ( $\phi 16$  mm  $\times$  150 m)
- Fair-lead
- Overhoist prevention device (for boom hoist and secondary hoist)

## ■ Standard and Optional Equipment

○: Standard ●: Option —: Not recommended

	CRAWLWER CRANE	CLAMSHELL	DRAGLINE
<b>Superstructure</b>			
Drum cooler (for aux. drum)	—	●	—
Side walk (folded type)	●	●	●
Side walk (fixed type with handrails)	●	●	●
Fuel double element	●	●	●
Engine air cleaner double element	●	●	●
<b>Cab</b>			
AM/FM radio	○	○	○
Fan	●	●	●
Loudspeaker	●	●	●
Heater	●	●	●
Air conditioner	●	●	●
<b>Safety devices</b>			
Foam type level (in cab)	●	●	●
Bucket overhoist prevention device	—	●	—
<b>Front attachments for crane and tower crane</b>			
40 ton hook (6-rope reevings)	○	—	—
15 ton hook (3-rope reevings)	●	—	—
6.5 ton hook	●	—	—
3 m boom insert	●	●	—
6 m boom insert	●	●	—
3 m angle chord boom insert	—	—	●
6 m angle chord boom insert	—	—	●
6 m jib assembly [6 m basic jib, aux. Jib hook overhoist prevention device, jib mast aux. Jib rope (φ22 mm × 115 m), 6.5 ton hook]	●	—	—
3 m jib insert	●	—	—
Aux. Jib assembly [aux. Jib, aux. Jib hook overhoist prevention device, aux. Jib rope (φ22 mm × 115 m), 6.5 ton hook]	●	—	—
Aux. Jib (aux. jib, aux. jib hook over hoist prevention device)	●	—	—
<b>Front attachment for other</b>			
0.8 m <sup>3</sup> clamshell bucket	—	●	—
1.0 m <sup>3</sup> clamshell bucket	—	●	—
1.2 m <sup>3</sup> clamshell bucket (light-service)	—	●	—
Hydraulic tagline	●	○	—
Open/close and suspend rope	—	○	—
1.15 m <sup>3</sup> Dragline bucket	—	—	●
Fair-lead	—	—	○