

**Technical Data**  
**Caractéristiques techniques**

# **LTM 1400**

**Mobile Crane**  
**Grue automotrice**

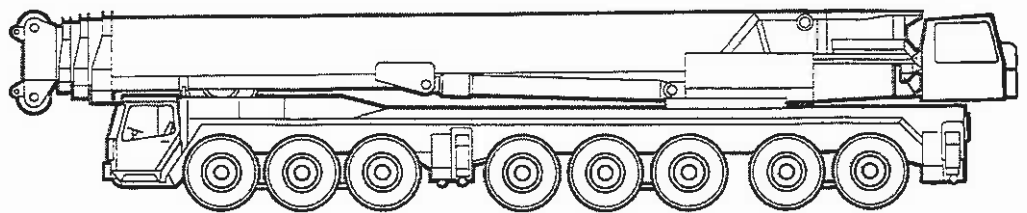

# **LIEBHERR**

# Lifting capacities at telescopic boom. Forces de levage à la flèche télescopique.

LTM 1400



52 ft - 164 ft



360°



276000 lbs

85%

ft	52 ft	70 ft	86 ft	89 ft	104 ft	120 ft	138 ft	154 ft	164 ft	ft		
10	956	839								10		
11	867	780								11		
12	794	729								12		
13	735	685								13		
14	702	653								14		
15	672	626	601							15		
16	642	606	580							16		
17	613	582	558	381						17		
18	583	557	537	369						18		
19	565	535	519	358						19		
20	547	515	502	348	371					20		
22	510	478	468	408	329	350				22		
24	475	445	437	384	312	330	290	239	252	219	24	
26	443	414	407	362	297	311	275	228	242	210	26	
28	415	389	382	343	284	295	262	219	232	202	189	28
30	390	366	359	324	271	279	249	209	223	185	184	30
32	368	345	339	307	258	266	238	200	215	188	177	32
34	349	328	321	292	248	253	228	192	207	182	171	34
36	331	312	305	279	239	242	218	184	200	176	165	36
38	314	295	289	267	229	231	208	177	192	170	158	38
40		274	255	220	220	198	170	155	185	164	153	40
45		246	230	200	198	178	155	167	150	150	141	45
50		220	207	184	180	162	143	151	138	138	128	50
55		196	188	170	164	148	132	137	127	127	117	55
60			172	159	150	137	122	126	118	118	108	60
65			158	147	138	127	113	118	110	110	100	65
70			143	137	128	117	106	109	103	103	92.5	70
75				128	119	108	98.5	101	95.5	95.5	88	75
80					111	101	92.5	95.5	89	89	80.5	80
85					104	94	87.5	88.5	84	84	75.5	85
90						97.5	88	82.5	82.5	79	71	90
95							83	78	78	74.5	67	95
100							78	74	73.5	70.5	63	100
105							74	71.5	69.5	66	59.3	105
110							64	67	66.5	62.5	56.1	110
115									63	59.2	53	115
120									59.3	56	50.2	120
125										53.2	47.7	125
130										50.1	45.3	130
135										47.2	43.1	135
140											40.9	140
145											38.8	145
150											36.9	150
I	0	50	92	0	92	92	0	92	92	100	I	
II	0	0	0	50	50	92	92	92	92	100	II	
% III	0	0	0	50	0	0	92	50	92	100	III %	

TAB 78044

## Remarks referring to load charts.

1. The tabulated lifting capacities do not exceed 85 % of the tipping load.
2. The crane's structural steelwork is in accordance with DIN 15018, part 3. Design and construction of the crane comply with DIN 15018, part 2, and with F. E. M. regulations.
3. The 85 % overturning limit values take into account wind force 5 = wind speed 20 mph.
4. Lifting capacities are given in kips.
5. The weight of the hook blocks and hooks must be deducted from the lifting capacities.
6. Working radii are measured from the slewing centreline.
7. The lifting capacities given for the telescopic boom only apply if the folding jib is taken off.
8. Lifting capacities are subject to modifications.

## Remarques relatives aux tableaux des charges.

1. Les forces de levage indiquées ne dépassent 85 % de la charge de basculement.
2. La norme DIN 15018, 3ème partie est appliquée pour les charpentes. La construction de la grue est réalisée conformément à la norme DIN 15018, 2ème partie, et aux règles de la F. E. M.
3. A 85 % de la charge de basculement, il a été tenu compte d'un vent de force 5 = vitesse de vent 20 mph.
4. Les forces de levage sont données en kips.
5. Le poids des mouffes et crochets doit être soustrait des charges indiquées.
6. Les portées sont calculées à partir de l'axe de rotation.
7. Les forces indiquées pour la flèche télescopique s'entendent fléchette dépliée.
8. Les forces de levage sont modifiables sans préavis.

# Lifting capacities are given in kips (1,000 lbs).

# Lifting capacities at guyed telescopic boom.

## Forces de levage à la flèche télescopique haubanée.

LTM 1400



86 ft - 164 ft



360°



276000 lbs

85%

ft	86 ft	89 ft	104 ft	120 ft		138 ft	154 ft	164 ft	ft
20	464	353	366						20
22	446	353	376						22
24	423	348	366	296	218	252	212		24
26	398	341	356	292	216	249	210		26
28	378	332	344	285	215	246	206	186	28
30	359	323	332	278	213	242	202	184	30
32	339	310	317	270	211	239	200	180	32
34	321	298	303	261	207	234	196	177	34
36	305	288	289	252	204	226	192	174	36
38	289	278	276	242	201	219	188	172	38
40	274	268	264	234	197	212	184	169	40
45	244	245	238	215	189	195	172	160	45
50	218	225	217	189	176	181	160	151	50
55	195	207	197	184	164	168	149	142	55
60	175	189	178	189	153	157	140	135	60
65	159	172	161	156	144	145	131	125	65
70	143	158	147	146	134	134	123	118	70
75		140	134	134	125	125	116	111	75
80			123	124	117	117	111	104	80
85			113	115	111	111	103	97.5	85
90			100	105	105	98.5	98	91.5	90
95				96.5	100	92.5	92.5	86	95
100				89	95.5	86	88	81.5	100
105				81.5	91.5	80	84	77	105
110				63.5	75.5	75	78.5	73	110
115						69	75	69.5	115
120							71	66	120
125							67	63.5	125
130							63	60.5	130
135							59.2	58.1	135
140								55.4	140
145								51.9	145
150								43.8	150
I	92	0	92	92	0	92	92	100	I
II	0	50	50	92	92	92	92	100	II
% III	0	50	0	0	92	50	50	100	III %

TAB 78051

# Lifting capacities at telescopic boom. Forces de levage à la flèche télescopique.

LTM 1400



52 ft - 164 ft



360°



209000 lbs

85%

ft	52 ft	70 ft	86 ft	89 ft	104 ft	120 ft	138 ft	154 ft	164 ft	ft				
10	956	839								10				
11	867	780								11				
12	794	729								12				
13	735	685								13				
14	685	643								14				
15	657	604	590							15				
16	621	577	565							16				
17	592	552	542	381						17				
18	568	528	519	389						18				
19	545	508	499	358						19				
20	523	488	480	434	348	371				20				
22	484	453	445	408	329	350				22				
24	449	422	413	384	312	330	290	239	252	219	24			
26	418	394	385	362	297	311	275	228	242	210	26			
28	392	369	361	343	284	295	262	219	232	202	189	28		
30	368	346	339	324	271	279	249	209	223	195	184	30		
32	346	326	319	305	259	266	238	200	215	188	177	32		
34	326	307	300	289	248	253	228	192	207	182	171	34		
36	307	291	283	275	239	242	218	184	200	176	165	36		
38	288	274	266	261	229	231	208	177	192	170	158	38		
40			250	248	220	220	198	170	185	164	153	40		
45			221	219	200	198	178	155	167	150	141	45		
50			196	192	184	180	162	143	151	138	128	50		
55			171	169	170	164	148	132	137	127	117	55		
60				146	159	149	137	122	126	118	108	60		
65				128	147	134	127	113	118	110	100	65		
70					115	134	121	117	106	109	103	92.5	70	
75						120	108	106	98.5	101	95.5	86	75	
80							96.5	96	92.5	95.5	89	80.5	80	
85								86.5	87.5	87.5	88.5	84	75.5	85
90								78	79	82.5	82	79	71	90
95									72	78	75	74.5	67	95
100									65.5	74	69	70	63	100
105									59.7	71.5	64	64.5	59.3	105
110									54.9	67	58.7	60	66.1	110
115											54.1	55.6	63	115
120											50	51.5	60.2	120
125												47.6	47.6	125
130												44.3	44.4	130
135												41.3	41.4	135
140													38.5	140
145													35.9	145
150													33.5	150
I	0	50	92	0	92	92	0	92	92	92	100	I		
II	0	0	0	50	50	92	92	92	92	92	100	II		
% III	0	0	0	50	0	0	92	50	92	100	100	III %		

<sup>1)</sup> over rear / en arrière

TAB 78033

# Lifting heights. Hauteurs de levage.

LTM 1400

Telescopic boom.  
Flèche télescopique.

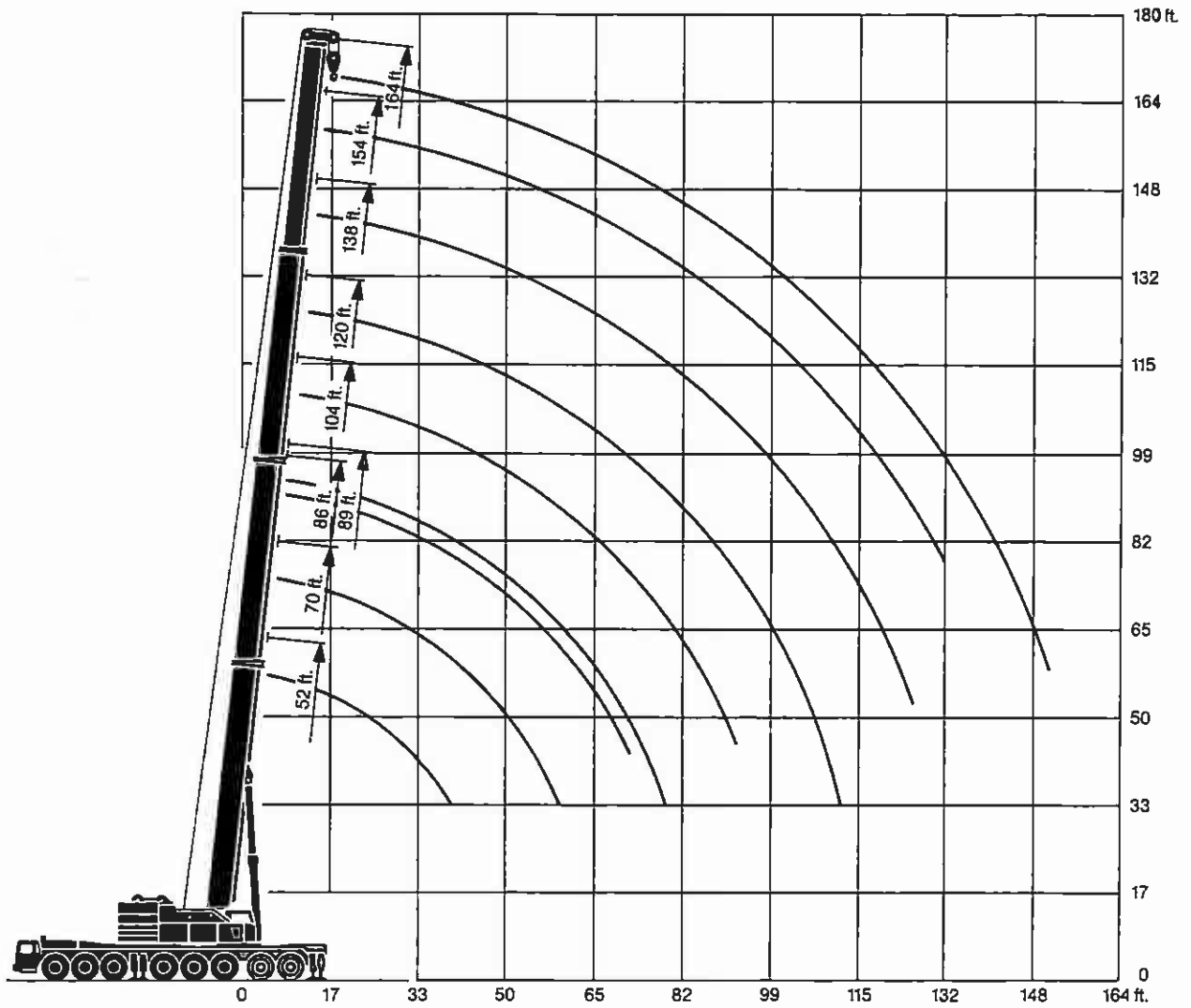

# Lifting capacities at the luffing lattice jib. Forces de levage à la fléchette treillis relevable.

LTM 1400



84°  
52 ft / 86 ft



69 ft - 276 ft



360°



209000 lbs



85%

ft	52 ft										86 ft										ft			
	69 ft	92 ft	115 ft	138 ft	161 ft	184 ft	207 ft	230 ft	253 ft	276 ft	69 ft	92 ft	115 ft	138 ft	161 ft	184 ft	207 ft	230 ft	253 ft	276 ft				
34	239																					34		
36	232																						36	
38	226																						38	
40	221	202									202												40	
45	209	195									197												45	
50	202	187	152								181	180											50	
55	185	180	148	121							184	157	127										55	
60	186	172	145	117	93.5						176	164	129	99									60	
65	166	160	142	115	92.5						161	152	144	97									65	
70	147	150	137	113	91	77.5					150	143	129	95.5	73								70	
75		140	131	111	90	76.5	62.5				134	120	94.5	72	57.3								75	
80		130	123	108	89	76	61.5	48.5			125	117	93.5	70	57.3	48.5							80	
85		122	113	106	87	75	61.5	48.5			117	113	91.5	68.5	57.3	48.5							85	
90		113	108	103	83	75	61	48.5	38.1		111	106	90.5	67	57.3	48.5	38.6						90	
95			102	97	80	74.5	60	48	37.6	28.7	104	100	88	65	57.3	48.5	38.1	30					95	
100			95	91	77	73	59.5	47.4	37.1	28.1			84.5	63.5	56.8	48.5	37.5	29.7	21.7				100	
105			88	86	74	69.5	59.5	47.4	36.6	27.8			88.5	78.5	61.5	55.1	48.5	37.5	29.3	21.2			105	
110			83	81	71	67	57.8	47.4	36.1	27.4			83.5	75	59.2	53.4	46.8	37.5	28.8	20.8			110	
115				77	68	64.5	57.3	46.8	35.6	27.1			79.5	71	57.3	52.3	45.1	36.9	28.4	20.5			115	
120				73	65	62	56.4	46.3	35.1	26.8				67	55.6	51.2	43.8	36.4	28	20.2			120	
125				68	62.5	60.5	53.9	46.3	34.6	26.4				64	53.9	49.6	42.9	36.3	27.5	19.8			125	
130				65	59.3	57.1	52.2	46.3	34.1	26.1				61.5	52.2	48.7	42.1	35.5	27.2	19.7			130	
135					56.5	54.6	50.5	45.7	33.5	25.8					50.2	47.2	41.3	34.6	26.8	19.4			135	
140					54	52.5	48.9	44.8	32.9	25.6					48.1	45.6	40.4	33.8	26.4	19			140	
150					49	47.9	45.5	42.7	31.7	25					44.9	42.7	38.7	32.6	25.6	18.6			150	
160						43.5	42.4	40.4	30.6	24.3						40.4	37.1	31.8	25	18.2			160	
170						40.9	39.8	38.7	29.6	23.6						38.7	35.4	30.9	24.3	17.9			170	
180							38.1	37	28.4	23						36.2	32.9	29.3	23.6	17.5			180	
190							35.9	34.8	27.4	22.3							31.4	28.1	23.1	17.2			190	
200								32.5	26.4	21.6								27.3	22.5	16.8			200	
210								30.9	25.4	20.7									26.5	21.8	16.3			210
220								29.2	24.5	20.1									25.6	21	16			220
230									23.4	19.3										20.4	15.6			230
240										18.5										19.9	15.3			240
250										17.8											15			250
260										17.1											14.6			260

Lengths of telescopic boom including 10 ft luffing lattice jib adapter.  
Longueurs de la flèche télescopique avec 10 ft raccord pour fléchette relevable.

TAB 78118.1

**Les forces de levage sont données en kips (1,000 lbs).**

# Lifting capacities at the lattice fly jib. Forces de levage à la flèche treillis fixe.

LTM 1400



138 ft\* - 164 ft\*\*



0°  
39 ft - 200 ft



360°



209000lbs

85%

ft	138 ft*		154 ft**								164 ft**		ft
	39 ft	39 ft	39 ft	62 ft	85 ft	108 ft	131 ft	154 ft	177 ft	200 ft	200 ft		
34	109	101										34	
36	106	99.5										36	
38	103	98										38	
40	101	96.5	87.5									40	
45	96.5	93	83.5									45	
50	92	89	79.5	63.5								50	
55	87	85.5	75.5	60.5	47.4							55	
60	83	82	72	58	45.3	35.8	28.9					60	
65	79	77.5	68	55.4	43.4	34.2	27.5					65	
70	75.5	74	64.5	52.9	41.6	32.6	26.5	21.4				70	
75	72.5	71.5	61.5	50.5	39.9	31.1	25.3	20.3	15.3	11		75	
80	69.5	68.5	58.8	48.2	38.4	29.7	24	19.2	14.4	10.2	9.8	80	
85	66.5	65.5	56	46.2	36.9	28.5	22.8	18.4	13.7	9.7	9.3	85	
90	64	62.5	53.6	44.2	35.4	27.3	21.9	17.4	12.9	9.2	8.8	90	
95	62	59.6	51.3	42.3	34	26.3	21	16.6	12.1	8.6	8.3	95	
100	59.9	56.8	49.1	40.5	32.6	25.2	20.1	15.8	11.5	8.1	7.8	100	
105	57.5	53.8	47	38.8	31.1	24	19.4	15	11	7.7	7.5	105	
110	55	51.3	45.1	37.1	29.9	23	18.6	14.3	10.4	7.4	7.2	110	
115	52.5	48.6	43.3	35.6	28.9	22.2	17.7	13.5	9.8	7	6.8	115	
120	49.9	46.1	41.3	34.2	27.8	21.6	16.9	12.8	9.4	6.7	6.5	120	
125	47.2	43.7	39.1	33	26.6	20.9	16.3	12.3	9	6.4	6.1	125	
130	44.4	41.7	37.3	31.6	25.8	20.1	15.6	11.8	8.7	6	5.6	130	
135	41.5	39.7	35.6	30.4	24.9	19.3	15.1	11.4	8.2	5.7	5.3	135	
140	39.8	37.8	33.9	29.4	24.1	18.7	14.6	11	7.8	5.4	5	140	
145	36.3	35.9	32.3	28.5	23.3	18.2	14	10.3	7.5	5.1	4.8	145	
150	33.9	33.5	31.1	27.5	22.4	17.4	13.5	10	7.1	4.9	4.7	150	
155	31.8	31.4	29.6	26.7	21.7	16.8	12.9	9.7	6.9	4.7	4.5	155	
160	29.3	29.5	28.3	25.6	21	16.3	12.4	9.3	6.7			160	
165	27.2	27.6	27	24.3	20.2	15.7	12.1	9	6.4			165	
170	25.4	25.6	25.3	23.3	19.5	15.1	11.7	8.6	6.2			170	
175		23.9	23.8	22.2	18.9	14.6	11.3	8.3	5.9			175	
180		22.2	22.3	21.1	18.3	14	10.9	8	5.5			180	
190			19.4	19.1	17.2	13	10.3	7.4	5.1			190	
200				17.2	16.1	12.1	9.8	6.9	4.7			200	
210				15	14.8	11.5	9.3	6.4	4.4			210	
220				12.8	13.3	10.6	8.9	5.9	4.1			220	
230					11.6	9.9	8.1	5.5	3.6			230	
240					10	9.1	7.5	5.2				240	
250						8.1	7	4.8				250	
260						6.7	6.5	4.5				260	
270							5.9	4.2				270	

\* with 5 ft boom extension / avec 5 ft extension de flèche  
 \*\* with 29 ft boom extension / avec 29 ft extension de flèche

TAB 78034



84°  
120 ft / 154 ft



69 ft - 276 ft



360°



209000 lbs



85%

ft	120 ft										154 ft										ft			
	69 ft	82 ft	115 ft	138 ft	161 ft	184 ft	207 ft	230 ft	253 ft	276 ft	69 ft	92 ft	115 ft	138 ft	161 ft	184 ft	207 ft	230 ft	253 ft	276 ft				
50	124																						50	
55	123	103									77													55
60	120	101	84.5								77	65												60
65	116	99.5	82								75	65												65
70	114	98.5	81	66.5							75	64.5	52.9											70
75	113	97.5	80	65.5	52.9						74	63.5	52.4	40.8										75
80		96.5	79	65	52.7	41.9					73	63	51.8	40.8	32.6									80
85		94	78.5	64	51.9	41.9					73	63	51.8	40.8	32.6									85
90		92	77.5	63	51.8	41.9	33.1					63	51	40	31.8	23.9								90
95		90.5	76	63	51.3	41.4	33.1	26.5				62.5	50.7	39.7	31.5	23.7	19.3							95
100		88.5	74.5	62.5	50.7	40.8	33.1	26.5	20.5			61.5	50.7	39.7	31.5	23.6	19.2	14.6						100
105			73	60.5	50.7	40.8	33.1	26.5	20.3	14.6		60.5	50.7	39.7	31.5	23.6	19.2	14.6						105
110			70	58.9	49.9	40.8	32.2	26.5	20.1	14.2		60.5	49.9	38.8	31.5	23.4	19	14.4						110
115			68.5	57.8	49	40.2	32	26.5	20	14			49.6	38.8	31.5	23.4	19	14.2	9.7					115
120			66.5	56.7	47.6	39.4	32	26.5	19.8	13.9			49.3	38.8	31.1	23.3	18.8	14.1	9.6					120
125				55	46.1	38.5	32	26.5	19.8	13.9			48.5	38.8	30.2	23.1	18.5	13.9	9.5					125
130				53.3	44.3	37.7	32	26.5	19.7	13.7			48.5	38.8	30.2	23	18.5	13.9	9.5					130
135				52.3	43.5	37.2	31.8	26.5	19.6	13.6				38.3	30.2	22.9	18.5	13.8	9.5					135
140				51.4	42.8	36.7	31.7	26.5	19.5	13.5				37.8	30.2	22.8	18.4	13.6	9.5					140
150					40.9	35.4	31	26	19.2	13.4				37.5	29.7	22.6	18.2	13.4	9.3					150
160							33.8	30	25.4	18.9	13.2				29.1	22.4	18	13.2	9					160
170							32.1	29.2	25.4	18.5	13				29.1	22.3	17.9	13	9					170
180							31.2	28.2	25.4	18.4	12.9					22.1	17.7	12.9	8.9	4.9				180
190								27.3	25.4	18.2	12.8					21.9	17.5	12.8	8.8	4.9				190
200								26.4	25.1	18	12.7						17.4	12.7	8.8	4.9				200
210									24.3	17.9	12.6						17.2	12.6	8.8	4.9				210
220									24.3	17.7	12.6						17	12.4	8.7	4.9				220
230										17.4	12.5							12.2	8.6	4.9				230
240										17.1	12.4								8.6	4.9				240
250											12.3								8.6	4.9				250
260											12.2								8.4	4.9				260
270											12.1								8.4	4.9				270

Lengths of telescope boom including 10 ft luffing lattice jib adapter.  
 Longueurs de la flèche télescopique avec 10 ft raccord pour fléchette relevable.



# Hauteurs de levage.

Luffing lattice jib.  
Flèche treillis relevable.

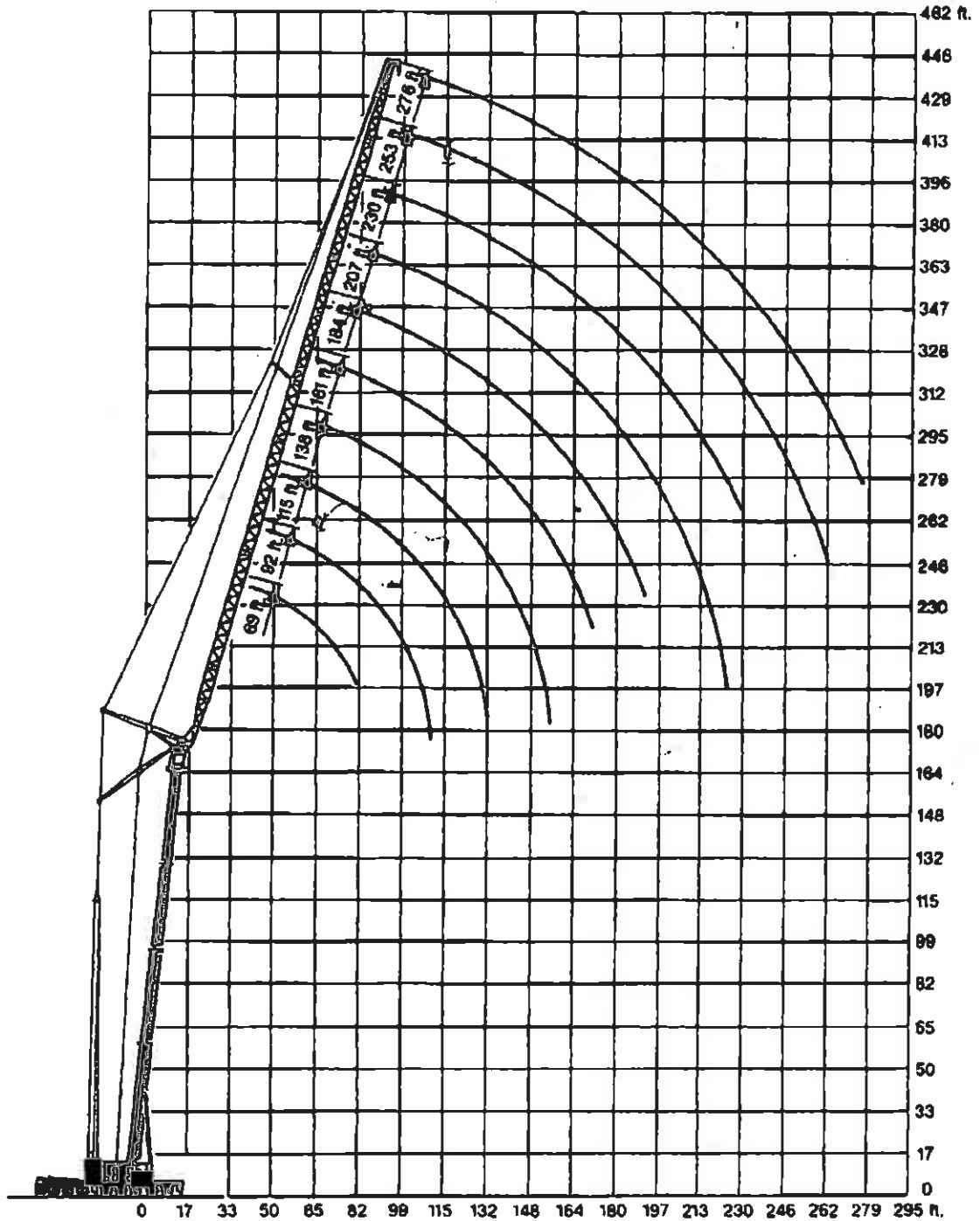



138 ft\*\*  
- 164 ft\*\*



20°  
39 ft - 154 ft



360°



209000lbs



85%

ft	138 ft**		154 ft**					164 ft**		ft
	39 ft	39 ft	62 ft	85 ft	108 ft	131 ft	154 ft	154 ft		
55	62								55	
60	60.5	57.9							60	
65	58.4	56.2							65	
70	56.7	54.5	40.1						70	
75	55.1	52.8	38.9						75	
80	53.3	51.3	37.8	27.8					80	
85	51.5	49.9	36.7	27					85	
90	49.6	48.3	35.8	26.3					90	
95	47.8	46.5	34.9	25.5	19				95	
100	46	44.7	33.9	24.7	18.3				100	
105	44.5	43	32.9	24	17.8	12.1			105	
110	43.2	41.3	31.7	23.5	17.1	12			110	
115	41.8	39.9	30.6	22.9	16.6	11.7			115	
120	40.5	38.5	29.7	22.3	16.1	11.3	8.5		120	
125	39.2	37.2	28.8	21.8	15.4	11	8.1	7.7	125	
130	38	36	28.2	21.3	14.9	10.5	7.8	7.5	130	
135	36.8	34.8	27.2	20.7	14.5	10.1	7.6	5.4	135	
140	35.6	33.7	26.4	20.1	14.3	9.8	7.4	5.2	140	
145	34.5	32.7	25.7	19.8	14.3	9.5	7.3	7	145	
150	33.5	31.3	24.9	19.3	14	9.3	7.1	6.7	150	
155	32.3	29.9	24.1	18.8	13.6	9.1	6.8	6.5	155	
160	30.8	28.4	23.4	18.3	13.2	8.9	6.5	6.3	160	
165	29	27.1	22.6	17.8	12.7	8.5	6.4	6.1	165	
170	27.1	25.9	22.1	17.3	12.4	8.2	6.2	5.8	170	
175	25.3	24.7	21.6	16.8	12.2	8	6	5.6	175	
180	23.4	23.4	21.1	16.4	12	7.8	5.7	5.4	180	
190		20.6	19.8	15.6	11.6	7.5	5.3	5.1	190	
200		17.6	18.2	14.8	11.1	7.2	5	4.7	200	
210			16.3	14.1	10.8	6.8	4.6	4.4	210	
220			14	13.3	10.3	6.7	4.3	4.1	220	
230				12.4	9.8	6.5	4.1	3.9	230	
240				11.2	9.3	6.3	3.9	3.6	240	
250					8.8	5.9	3.7	3.3	250	
260					8.3	5.6	3.4	3.1	260	
270					7.9	5.4	3.2		270	
280					7.1	5.2			280	

\*\* with 29 ft boom extension / avec 29 ft extension de flèche.

# Lifting heights. Hauteurs de levage.

LTM 1400

Lattice fly jib.  
Fléchette treillis fixe.

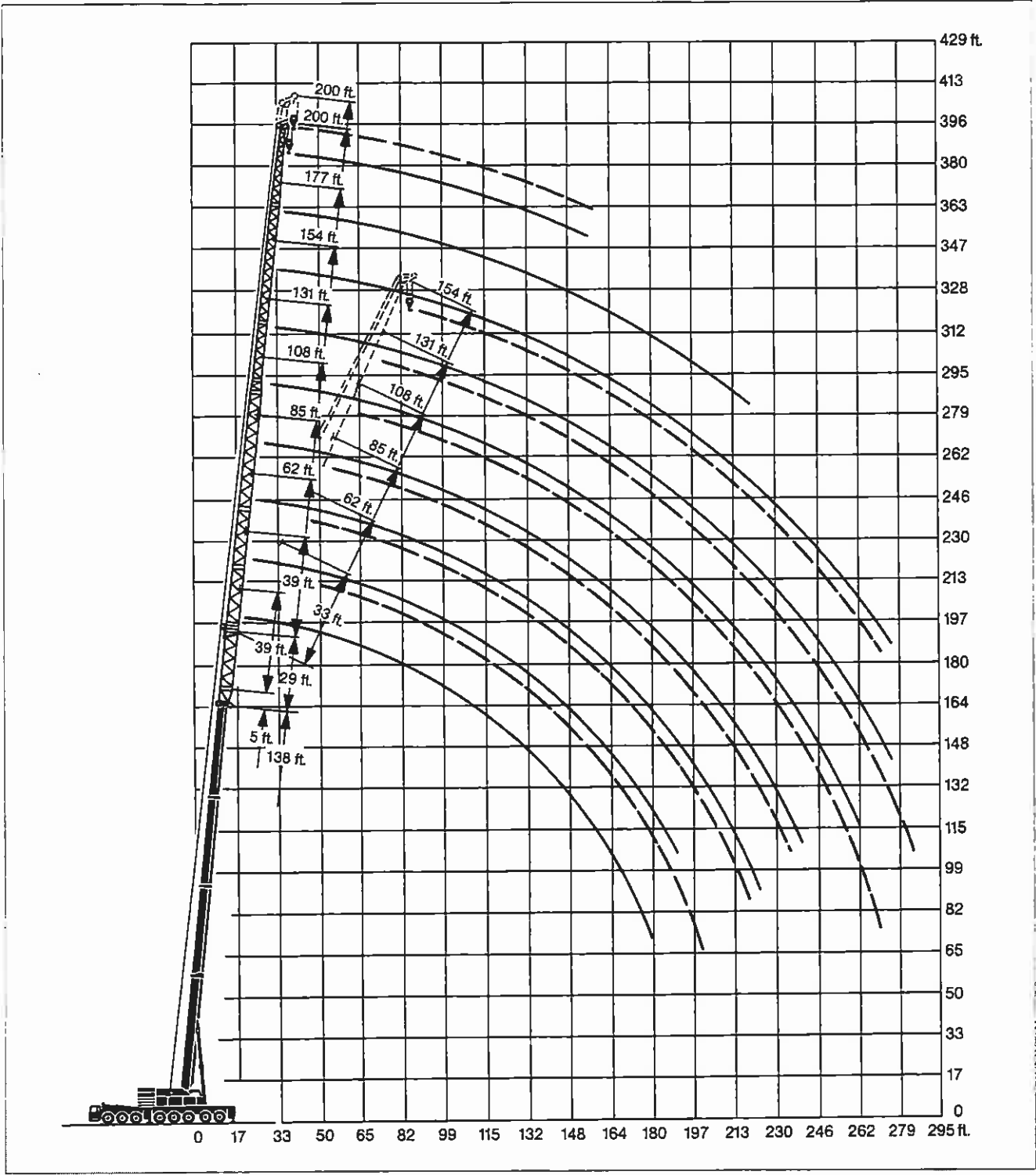



# Weights. Poids.

LTM 1400



Azle Essieu	1	2	3	4	5	6	7	8	Total weight Poids total
lbs	26500	26500	26500	26500	26500	26500	26500	26500	212000



Load (kips) Forces de levage (kips)	No. of sheaves Poulies	No. of lines Brins	Weight lbs Poids lbs
507	11	22	5732
341.7	7	14	4409
178.6	3	7	3307
79.4	1	3	2205
26.5	-	1	1102

# Working speeds. Vitesses.



	1	2	3	4	5	R		
	8	13	22.4	29.8	40.4	8.5	16%	
	3.7	6.2	9.9	14.3	19.3	4.1	31%	
	16.00 R 25							



Drive Mécanismes	infinitely variable en continu	Rope diameter / Rope length Diamètre du câble / Longueur du câble	Max. single line pull Effort au brin maxi.
	0 - 526 ft/min single line ft/mn au brin simple	3/8" / 1575'	26900 lbs
	0 - 526 ft/min single line ft/mn au brin simple	1/4" / 2460'	26900 lbs
	0 - 1,2 rpm		
	approx. 100 seconds to reach 83° boom angle env. 100 s jusqu'à 83°		
	approx. 130 seconds / 350 seconds for boom extension from 52 ft - 164 ft env. 130 s / 350 s pour passer de 52 ft - 164 ft		

# Crane carrier.

LTM 1400

<b>Frame:</b>	Liebherr designed and manufactured, box type, torsion resistant, all-welded construction made of high-tensile structural steel.
<b>Outriggers:</b>	4 sliding beams with hydraulic extension cylinders and hydraulic support pad jacks. Front outriggers mounted between axles 3 and 4, rear outriggers at rear of truck chassis.
<b>Engine:</b>	Diesel, 8 cylinder, watercooled, make Liebherr, type D 9408 TI-E, output 420 kW DIN (570 HP) at 2100 rpm acc. to ECE-R 24.03 and ECE-R 49.02 (EURO II), max. torque 1718 lbs-ft at 1500 rpm. Fuel tank capacity: 162 gallons.
<b>Transmission:</b>	Allison type CLBT 755 automatic transmission with torque converter and hydrodynamic retarder brake. 5 forward speeds, 1 reverse. Splitter gearbox with differential and differential lock, off-road range.
<b>Axles:</b>	Heavy duty crane truck axles, all 8 axles sprung. Axles 1 to 4 and 7 and 8 steered. Axles 1, 2, 5 and 6 are planetary axles with differential locks.
<b>Suspension:</b>	All axles are hydropneumatically sprung with automatic levelling. Load equalization between axle pairs 1 + 2, 3 + 4, 5 + 6 and 7 + 8. Suspension hydraulically locked.
<b>Tyres:</b>	16 tyres, all axles with single tyres. Tyre size: 16.00 R 25.
<b>Steering:</b>	ZF semi-unitary hydraulic power steering, dual circuit system, with hydraulic servo mechanism and auxiliary pump circuit from final drive.
<b>Brakes:</b>	Service brake: servo assisted air brakes acting on all wheels, dual circuit system. Hand brake: spring-action, acting on all wheels of axles 5 to 8.
<b>Driver's cab:</b>	Large-area, all-steel cab with resilient mountings, safety glass windows and full range of instruments.
<b>Electrical system:</b>	24 Volts DC, 2 batteries, lighting to German road vehicle regulations.

# Crane superstructure.

<b>Frame:</b>	Liebherr-made, torsion-resistant, welded construction made of high-tensile structural steel. Connection to truck chassis by triple roller slewing ring, designed for 360° continuous rotation.
<b>Crane engine:</b>	Diesel, 6 cylinder, watercooled, make Liebherr, type D 926 TI-E, output 240 kW DIN (326 HP) at 1800 rpm, max. torque 1090 lbs-ft at 1800 rpm.
<b>Crane drive:</b>	Diesel-hydraulic, with 5 axial piston swivelling pumps with servo control and automatic output regulation.
<b>Crane control:</b>	By self-centering control lever, movable in 4 directions (cross-control arrangement).
<b>Main winch:</b>	Axial piston swivelling motor; full hydraulic power up and down. Hoist drum with integrated planetary gear and spring loaded brake.
<b>Luffing gear:</b>	Twin double-acting hydraulic cylinders with integral safety locking valves.
<b>Slewing gear:</b>	Planetary gear with flange connected hydraulic motor and spring loaded brake.
<b>Crane cab:</b>	All-steel construction, safety glazing, controls and instruments. Crane cab is swing to rear when driving on road.
<b>Safety devices:</b>	Electronic load-moment limiter, hoist limit switch, safety valves to protect hydraulic system against pipe and hose fracture.
<b>Telescopic boom:</b>	1 boom pivot section and 3 telescopic sections. All sections separate hydraulically extendable. Boom length: 52 ft - 164 ft.
<b>Electrical system:</b>	24 Volts DC, 2 batteries.

# Additional equipment.

<b>Lattice jibs:</b>	Luffing lattice jib 69 ft - 276 ft, lattice fly jib 39 ft - 200 ft.
<b>Hoisting gear 2:</b>	For two-hook operation or to luff the lattice fly jib.

Other items of equipment available on request.

## Châssis porteur.

<b>Châssis:</b>	Fabrication Liebherr, construction en caisson indéformable, en acier grain fin à haute résistance.
<b>Stabilisateurs:</b>	Quatre poutres télescopiques, avec vérins d'appui hydrauliques et semelles. Les carters des poutres de stabilisation avant sont disposés entre les essieux 3 et 4, les carters AR à l'arrière du châssis.
<b>Moteur:</b>	Diesel, 8 cylindres, marque Liebherr, type D 9408 TI-E, refroidissement par eau, puissance 420 kW DIN (570 ch) à 2100 rpm selon ECE-R 24.03 et ECE-R 49.02 (EURO II), couple maxi. 1718 lbs-ft à 1500 rpm. Capacité du réservoir carburant: 162 gallons.
<b>Boîte:</b>	Boîte automatique, marque Allison, type CLBT 755, avec convertisseur de couple et ralentisseur hydraulique. 5 rapports AV et 1 AR. Boîte de transfert avec répartiteur différentiel et rapport tout terrain.
<b>Essieux:</b>	Essieux spéciaux lourds. Tous les 8 essieux disposent d'une suspension intégrale. Les essieux 1 à 4 et 7 et 8 sont directeurs. Les essieux 1, 2, 5 et 6 sont à trains planétaires avec blocage des différentiels.
<b>Suspension:</b>	Tous les essieux disposent d'une suspension hydropneumatique avec système d'équilibrage automatique. Dispositif de répartition des charges entre les essieux 1 + 2, 3 + 4, 5 + 6 et 7 + 8. Suspension blocable hydrauliquement.
<b>Pneumatiques:</b>	16 pneumatiques, tous les essieux munis de roues simples. Dimension des pneumatiques: 16.00 R 25.
<b>Direction:</b>	Direction hydraulique semi-bloc ZF, à deux circuits, assistée hydrauliquement, avec pompe auxiliaire entraînée par essieu.
<b>Freins:</b>	Assistés pneumatiquement, agissant sur toutes les roues, conformes au code. Frein à main: par cylindres à ressort agissant sur les essieux 5 à 8.
<b>Cabine:</b>	Cabine spacieuse entièrement réalisée en tôles d'acier, suspension assurée par silent-blocs, vitrage de sécurité, tableau de bord complet.
<b>Installation électrique:</b>	24 volts continus, 2 batteries, éclairage conforme au code.

## Partie tournante.

<b>Châssis:</b>	De fabrication Liebherr, soudé, en acier spécial, résistant à la torsion. Couronne d'orientation à triple rangée de rouleaux, orientation sur 360°.
<b>Moteur:</b>	Diesel, 6 cylindres, marque Liebherr, type D 926 TI-E, refroidissement par eau, puissance 240 kW DIN (326 ch) à 1800 rpm <sup>-1</sup> , couple maxi. 1090 lbs-ft à 1200 rpm.
<b>Entraînement:</b>	Diesel-hydraulique comprenant 5 pompes à débit variable à servo-commande et régulation de puissance.
<b>Commande:</b>	Deux leviers quatre directions à rappel automatique au point mort.
<b>Mécan. de levage principal:</b>	Moteur hydraulique à cylindrée variable, treuil de levage avec réducteur planétaire incorporé et frein d'arrêt commandé par ressort.
<b>Mécan. de relevage:</b>	Deux vérins différentiels, avec clapet anti-retour de sécurité.
<b>Orientation:</b>	Moteur hydraulique, réducteur planétaire, pignon d'orientation et frein d'arrêt commandé par ressort.
<b>Cabine:</b>	Entièrement réalisée en tôles d'acier avec vitrage de sécurité, organes de commande et appareils de contrôle. Pour les déplacements sur route, la cabine de la tourelle doit être orientée vers l'arrière.
<b>Sécurités:</b>	Limiteur du couple électronique, fin de course de levage, soupapes de sûreté, sur tubes et flexibles.
<b>Flèche télescopique:</b>	Flèche à télescopage hydraulique formée d'un élément de base et de 3 éléments télescopiques. Télescopage individuel de toutes les éléments télescopiques. Longueur de flèche: 52 ft - 164 ft.
<b>Installation électrique:</b>	24 volts continus, 2 batteries.

## Équipement optionnel.

<b>Fléchettes treillis:</b>	Fléchette treillis relevable 69 ft - 276 ft, fléchette treillis fixe 39 ft - 200 ft.
<b>Mécan. de levage secondaire:</b>	Pour le travail avec 2 crochets ou le relevage de la fléchette treillis.

Autres équipements supplémentaires sur demande.

Subject to modification. / Sous réserve de modifications.

TP 88 CA b. 7.97

**Please contact**  
**Veillez prendre contact avec**  
**LIEBHERR-WERK EHINGEN GMBH**  
**D-89582 Ehingen/Donau, Telefon (0 73 91) 5 02-0, Telefax (0 73 91) 5 02-3 99**