

GTC-1000EX

100t Telescopic Boom Crawler Crane



 TADANO

MANTIS
CRANES

SPECIFICATIONS & LOAD CHARTS



MANTIS[®]

CRANES

Tadano Mantis Corporation builds on the long tradition of the Mantis telescopic boom crawler crane, and sets the global standard with the dependability, versatility and performance expected of a market leader. Tadano Mantis cranes are built like no other. At their hearts are massive steel fabrications, over-sized to handle the toughest jobs, year-in and year-out. Powerful state-of-the-art hydraulics coupled with diesel engines available in a choice of sizes match perfectly to meet the most rigorous of project demands. Tadano Mantis Corporation remains one of the few crane makers prepared and equipped to work with contractors and project engineers to develop customized lifting solutions that meet the most unusual of project challenges. Thanks to the versatile combination of heavy duty telescopic booms, hydraulically extendable crawlers, and extremely compact dimensions, Mantis cranes can often get closer to a job than bulkier, fixed length lattice boom crawler cranes or rubber-tired cranes that need outriggers to work effectively.



FEATURES

NO OTHER CRANE COMBINES SO MANY VALUABLE FEATURES:

- Pick-and-carry the full crane load chart through 360°.
- Lift and walk...even with tracks retracted.
- Climb steeper grades, thanks to minimized counterweight and low center of gravity.
- Pull through deep mud without bogging down.
- Telescope or lift the boom with a full load on the hook.
- Save time and money on the job due to low clearance height, retract on-the-fly tracks and telescopic boom.
- Independent hydrostatic track drives allow pivot turns and counter rotation.
- Hydraulic tool circuit option powers wide choice of Mantis-approved tools.
- New luxury cab with state-of-the-art operator aids.
- Saves time and money on deployment and shipping with less haul vehicles, less time wasted on boom erection and fewer personnel on the erection crew.



Large access doors, spacious machinery compartments simplify preventative maintenance and service of the crane.



Conveniently positioned cameras display the winch as well as the blind area directly behind the crane. Full color video display in operator cab is standard equipment.



Spacious cab, adjustable seat, and conveniently located controls are common in all Tadano Mantis Cranes.



State-of-the-art, user friendly rated capacity limiter provides continuous feedback of crane lift and position data.

ON THE JOB

The Tadano Mantis GTC-1000EX telescopic boom crawler crane is well suited for standard lift crane work, as well as the rigors of heavy-duty and duty cycle work. The massive structures and strong boom allow this crane to handle vibratory hammers and other ground engaging tools. The GTC-1000EX is an ideal replacement for lattice boom crawlers, and it offers the flexibility of a full power synchronized telescopic boom. With its long boom length of up to 59.9m when the lattice extension and jib are installed, the crane has plenty of reach to erect high electrical towers or tail wind turbine rotors.



■ Full power telescopic boom with extension installed. Quickly adjust crane boom configuration during assembly of structures of varying heights.

KEY FEATURES INCLUDE:

- 100t pick-and-carry capacity at 2,5m radius thru 360°.
- Sequence-synchronized four-section full power boom of 39,0m length.
- Lattice boom extensions and offsettable jibs for up to 59,7m tip height.
- 261kW diesel engine standard.
- Low ground bearing pressure of 0,77 kg/cm².
- Auger options with optional hydraulic tool circuit.
- Fast two-speed independent hydrostatic track drive to 2,5 km/hr.
- Steep 60% gradeability.
- Full boom telescoping and boom lift under full hook load.
- 3,93m minimum travel width according to tracks selected.
- Tilting cab for increased operator comfort and reduced fatigue.

GTC-1000EX

100t Telescopic Boom Crawler Crane



The GTC-1000EX quickly and easily self-erects at job site.



The heavy-duty construction of the GTC-1000EX makes the crane ideally suited for foundation projects.



Long distances between site locations are easily traveled with fast travel speeds and a high capacity, demand based cooling system.



Full pick and carry capacity and long boom make the crane ideal for handling heavy turbine machine packages and long wind turbine blades.

DIMENSIONS

GTC-1000EX

100t Telescopic Boom Crawler Crane

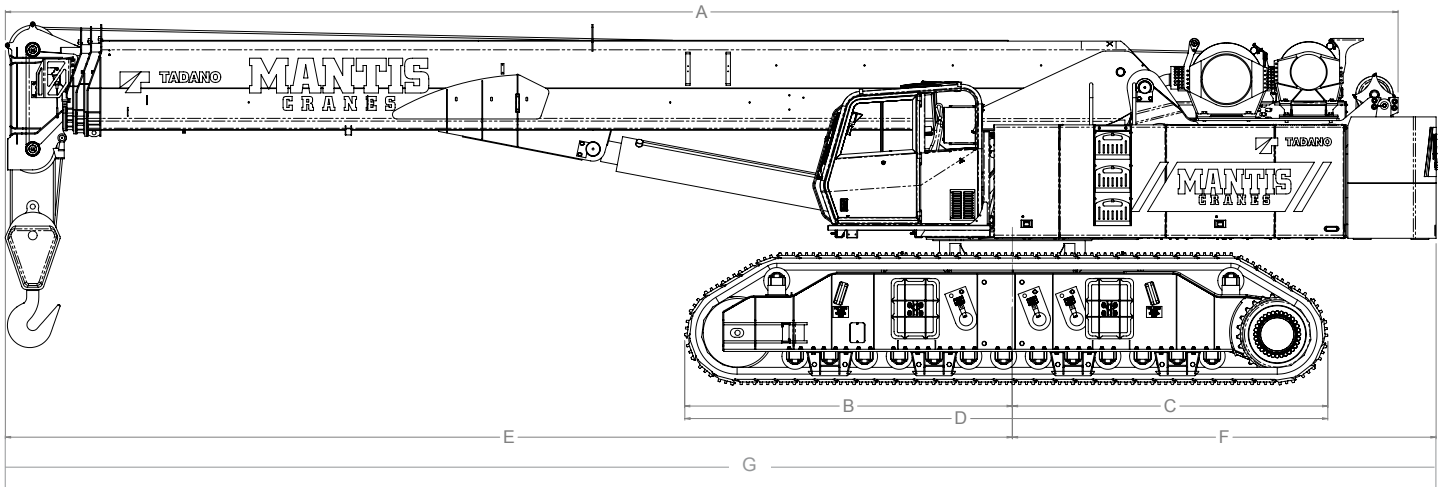

PRINCIPAL DIMENSIONS

A	Length (Counterweight Removed)	16.04 m
B	CL Front Track Drive to CL Rotation	3.15 m
C	CL Rear Track Drive to CL Rotation	3.05 m
D	Track Length	7.42 m
E	Boom Length to CL Rotation	11.43 m
F	Tailswing	4.88 m
G	Overall Length	16.46 m
H	Ground to Top of Engine Cover	3.33 m
I	Track Height	1.57 m
J	Ground Clearance	610 mm
K	Ground to Bottom of Cab	1.88 m
L	Maximum Overall Height	3.99 m
M	Track Width	900 mm
N	Overall Width (Tracks Retracted)	3.94 m
O	Overall Working Width	6.43 m

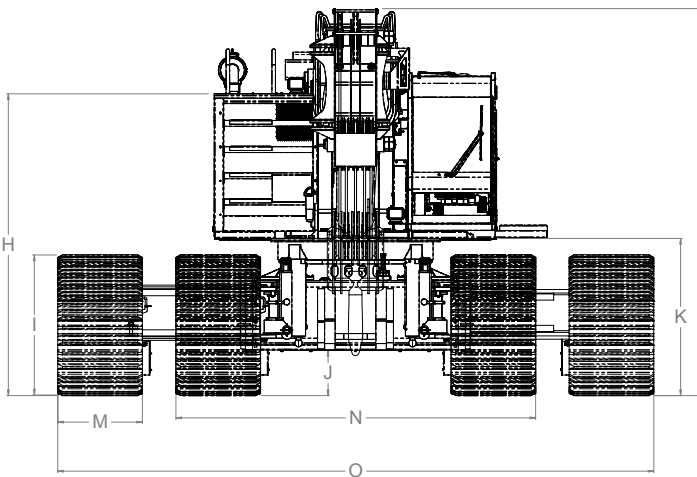

WIDTHS, WEIGHTS, AND GROUND PRESSURES*

Shoe Width	Overall Width		Area	Ground Pressure	Working Weight
	Retracted	Extended			
900 mm	3.94 m	6.43 m	11.38 m ²	0.80 kg/cm ²	91,762 kg

* Crane equipped with: 39.0m boom, extension, jib, 90t hook block, and 11t headache ball

TRANSPORT DIMENSIONS (TRACKS REMOVED)

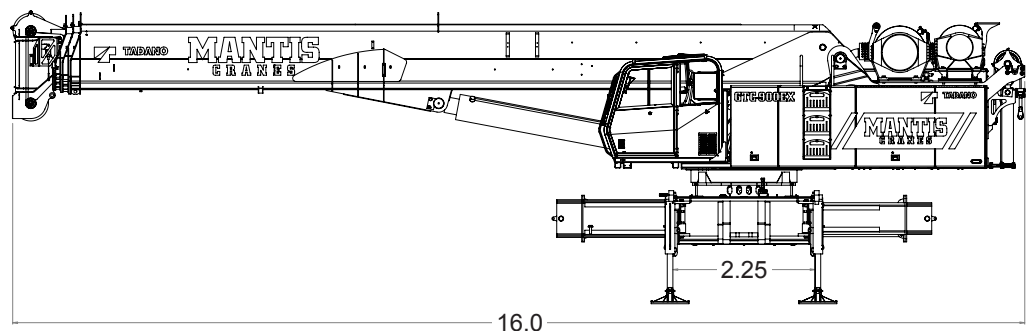
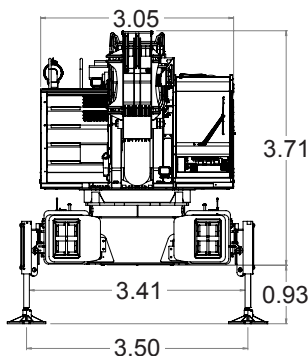



1 Select firm and level site



5 Remove track Frames



2 Remove counter weights

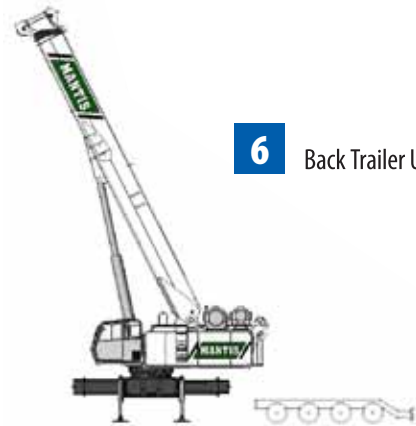

6 Back Trailer Under Crane



3 Rotate Upper over side



7 Retract Carbody Jacks

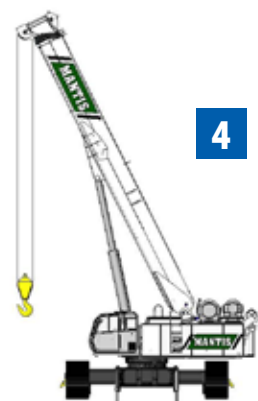

4 Extend Carbody Jacks

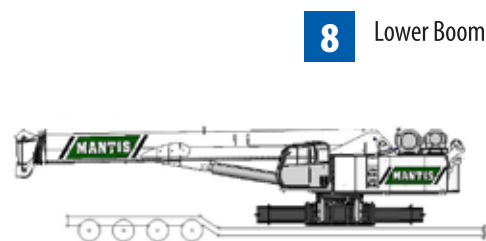

8 Lower Boom

MAJOR COMPONENT SHIPPING WEIGHTS SHOWN ON PAGE 10.

CRANE SPECIFICATION

Boom

4-section full power synchronized telescoping boom. Synchronized telescoping system consists of two double acting hydraulic cylinders with load holding valves and extension and retraction cables.

Telescoping System: Two double acting hydraulic cylinders with load holding valves and extension and retraction cables

Retracted Length: 12,8m

Extended Length: 39,0m

Boom Extension Time: 116s

Maximum Lifting Height: 40,3m

Elevating System: Double acting hydraulic cylinder with load holding valves

Elevating Angles: -1° to 80°

Boom Elevation Time: 74s

Boom Head: Seven, 559 mm diameter cast nylon sheaves on heavy-duty roller bearings

Auxiliary Boom Head: Quick reeve, single 559 mm diameter high-strength, cast nylon sheave mounted on a heavy-duty roller bearing.

Hook Block: 90t hook block - Five 508 mm diameter sheaves mounted on heavy-duty roller bearings with swivel hook and safety latch

Headache Ball: 11t ball includes a swivel hook with a safety latch.

Load Moment Indicator & Anti-Two Block

- Standard Rated Capacity Limiter and Anti-Two Block system
- Control function shutdown
- Audio and visual warnings
- LCD screen provides a continuous display of working boom length, boom angle, working load radius, tip height, parts-of-line (operator set), machine track configuration, relative load moment, maximum permissible load and actual load.
- Anti-two block weight allows quick reeving of hook blocks.

SUPERSTRUCTURE

Frame

The frame is an all-steel, welded structure, precision machined to accept attachment of the boom and swing components.

Operator's Cab

- Fully-enclosed, air conditioned all-steel modular cab with lockable swinging door, acoustical lining, anti-slip floor and tinted safety glass.
- Sliding windows located in the cab door and cab boom side.
- Vent window in the rear of the cab.
- Cab tilts up to 20°.
- Grab bars and steps are located for easy access to the cab.
- Rear view cameras are appropriately located as are three remote control work lights.
- 2-speed windshield wiper, top glass wiper
- Defroster, heater, circulating fan
- Six-way adjustable fabric seat with headrest, seat belt
- Dome light
- Dry-chemical fire extinguisher.
- Dash instrumentation: tachometer, voltmeter, oil pressure gauge, temperature gauge, hour meter and fuel gauge. Indicators are provided for crane level, load moment, drum rotation, air filter restriction, hydraulic oil temperature and filter restriction, engine oil pressure and temperature.
- Seat and armrest termination switches immediately disable all hydraulic functions as the operator rises from the seat or lifts the left hand armrest.
- Two-way hydraulic armrest mounted joysticks control swing, auxiliary winch, main winch and boom hoist. Four, two-way hydraulic foot pedals control the travel, boom extend, and swing service brake functions.
- Adjustable hand and foot throttles

Counterweight

The 15,985 kg two piece counterweight can be removed and installed via a hydraulic counterweight cylinder and electronic control pendant.

Swing

Gear motor driving a planetary gear reducer with a shaft mounted pinion, external gear shear ball slew bearing bolted to the superstructure and the carbody allows the superstructure to rotate 360°

Free Swing system

Swing Speed: Up to 2 rpm

Swing Parking Brake: Spring applied failsafe brake with hydraulic release that is controlled from the operators cab

Swing Service Brake: Hydraulically applied controlled through foot actuated pedal

House lock system: 2-position manually pinned

Lubrication system: Cab mounted grease applicator

Fuel System

Capacity: 625 liter

Filtration: Inline fuel/water separator and engine mounted fuel filter.

Hydraulic System

Hydraulic Pumps:

Two high pressure, variable axial piston pumps with load sense and Electronic power limiting control for crane functions. One variable piston pump for cooling loop Multiple pressure and flow compensated valves with integrated relief valves controlled by hydraulic pilot signals. 795 liter/min @ 2100 RPM engine speed. 330 bar maximum pressure

Directional Valves:

Pump output:

Reservoir:

1,400 liter capacity, spin-on filler/breather, sight gauge, cleanout, and sump drain.

Filtration:

5 micron, full flow tank mounted return filters with electrical clogging indicator; 5 micron pilot oil in-line pressure filter with electrical clogging indicator.

Diagnostic Ports:

Provided for system, load sense, and pilot pressure.

UNDERCARRIAGE

Carbody

The steel box type carbody is fabricated with square axles to accept the crawler side frames. The top surface is precision machined to receive the swing bearing.

Side Frames

Two welded steel side frames are paired with a track group. The side frames extend and retract hydraulically and are controlled from the cab.

Track Rollers: Two top and thirteen bottom sealed rollers on each track frame

Idler: Oil filled, self lubricating with spring type tensioner

Track Shoes: 900mm 3-bar semi grouser (standard)

Travel

Each side frame contains a pilot controlled, two-speed track drive with hydraulic axial piston motor and parking brake. Travel system provides skid steering and counter rotation.

Low travel speed: 0,9 km/h

High travel speed : 2,5 km/h

Gradeability (unladen): 60%

OPTIONAL EQUIPMENT

Boom Extension: Lattice type, swingaway, stores along boom base section and can be used with or without optional jib. One of two parts of line may be reeved.

Length: 10,7m

Head: Two, 559 mm diameter cast nylon sheaves on heavy-duty roller bearings

Maximum Lifting Height: 50,9m

Boom Jib: Lattice type, swingaway, stores along boom extension and can only be used with extension deployed.

Length: 7,6m

Offset Angles: 15° & 30°

Maximum Lifting Height: 58,4m

Hook Block: 63t hook block - Three 508 mm steel sheaves, swivel hook & safety latch

100t hook block - Five 508 mm diameter sheaves mounted on heavy-duty roller bearings with swivel hook and safety latch

Auger Ready Package: Includes hoses, fasteners and stowage bracket assembly mounted to the base section of the boom with a flow capability of 130 liter/min

Complete Auger Package: Adds a two speed auger motor/gear box and one 1,52 m kelly bar to the Auger Ready Package.

Tool Circuit: Provides 23 liter/min and 45 liter/min at 176 bar through a 15,2m twin hose reel with quick disconnect fittings to operate open center tools.

Free Fall Hoists: All winches are available in controlled free fall configurations.

Access Walkways: Cab walkway and folding walkways along each side of the superstructure.

¹Load moment indicating and anti-two block systems are operator aids and must never be used in lieu of job site lift planning calculations by the operator which must take into account ground conditions, weather and all other environmental factors prevailing at the time of the lift. Prices and specifications are subject to change at any time without prior notice and are for factory installation at time of original manufacture. F.O.B Plant; Richlands, VA 24641. Illustrations and photographs may show optional equipment. Supercedes all previous issues. Please see www.mantiscranes.com for most current information.

MAIN WINCH					
Planetary geared two-speed winch includes a bent axis, variable displacement hydraulic motor and a multi-disc internal brake. Wire Rope: 305 m 22 mm 6 x 37 EIPS, IWRC, RRL. Line pulls are not based on wire rope strength.					
Rope Layer	Maximum Line Pull (kN)	Full Load Line Speed (m/min)	Pitch Diameter (mm)	Layer (m)	Total (m)
1	106,7	39,1	480,3	35,3	35,3
2	97,4	42,9	526,5	38,7	74
3	89,5	46,6	572,8	42,1	116,1
4	82,8	50,4	619	45,5	161,6
5	77,1	54,2	665,2	48,9	210,5
6	72,1	57,9	711,5	52,3	262,8
7	67,7	61,7	757,7	55,7	318,5

AUXILIARY WINCH					
Planetary geared two-speed winch includes a bent axis, variable displacement hydraulic motor and a multi-disc internal brake. Wire Rope: 137 m 22 mm 6 x 37 EIPS, IWRC, RRL. Line pulls are not based on wire rope strength.					
Rope Layer	Maximum Line Pull (kN)	Full Load Line Speed (m/min)	Pitch Diameter (mm)	Layer (m)	Total (m)
1	106,7	39,1	480,3	35,3	35,3
2	97,4	42,9	526,5	38,7	74
3	89,5	46,6	572,8	42,1	116,1
4	82,8	50,4	619	45,5	161,6
5	77,1	54,2	665,2	48,9	210,5

ENGINE					
Cummins QSM11 (U.S. EPA Tier 3, CARB Tier 3, Euromot Stage IIIA)			Noise Emissions: Top 96.3 dBa (excludes noise from intake, exhaust, cooling system and driven components)		
Type	6 Cylinder Water Cooled	Weight (Wet)	985 kg	Aspiration	Turbocharged & Aftercooled
Displacement	10,8 liter	Oil Capacity	16,3 liter	Air Filter	Dry Type
Bore	125 mm	Rated Power	261 kw @ 2100 rpm	Electrical System	12 volt
Stroke	147 mm	Peak Torque	1675 Nm @ 1400 rpm	Alternator	130 amp

MACHINE WEIGHTS	
STANDARD CRANE WITH 4 SECTION 39,0 m BOOM, 2 PIECE COUNTERWEIGHT & 900 mm TRACK SHOES	87,537 kg
Crane Less Counterweights and Track Frames	45,699 kg
Counterweight, 2 pieces (1 piece @ 8,210 kg each and 1 piece @ 7,775 kg)	15,984 kg
Track Frames, 2 pieces 12,927 kg each	25,854 kg
Auxiliary Winch with Standard Rope	1,180 kg
Auxiliary Nose Sheave	113 kg
11t Headache Ball	270 kg
90t Hook Block	1,134 kg
OPTIONAL EQUIPMENT	
10,7 m Lattice Extension	1,154 kg
7,6 m Jib (connects to head of Lattice Extension ONLY)	379 kg
Auger Ready Package	200 kg
Complete Auger Package	690 kg
1,5 m Auger Kelly Bar	54 kg
63t Hook Block	642 kg
100t Hook Block	1,176 kg

* Deduction from Standard Crane Weight

39M MAIN BOOM, 10,7M EXTENSION & 7,6M JIB

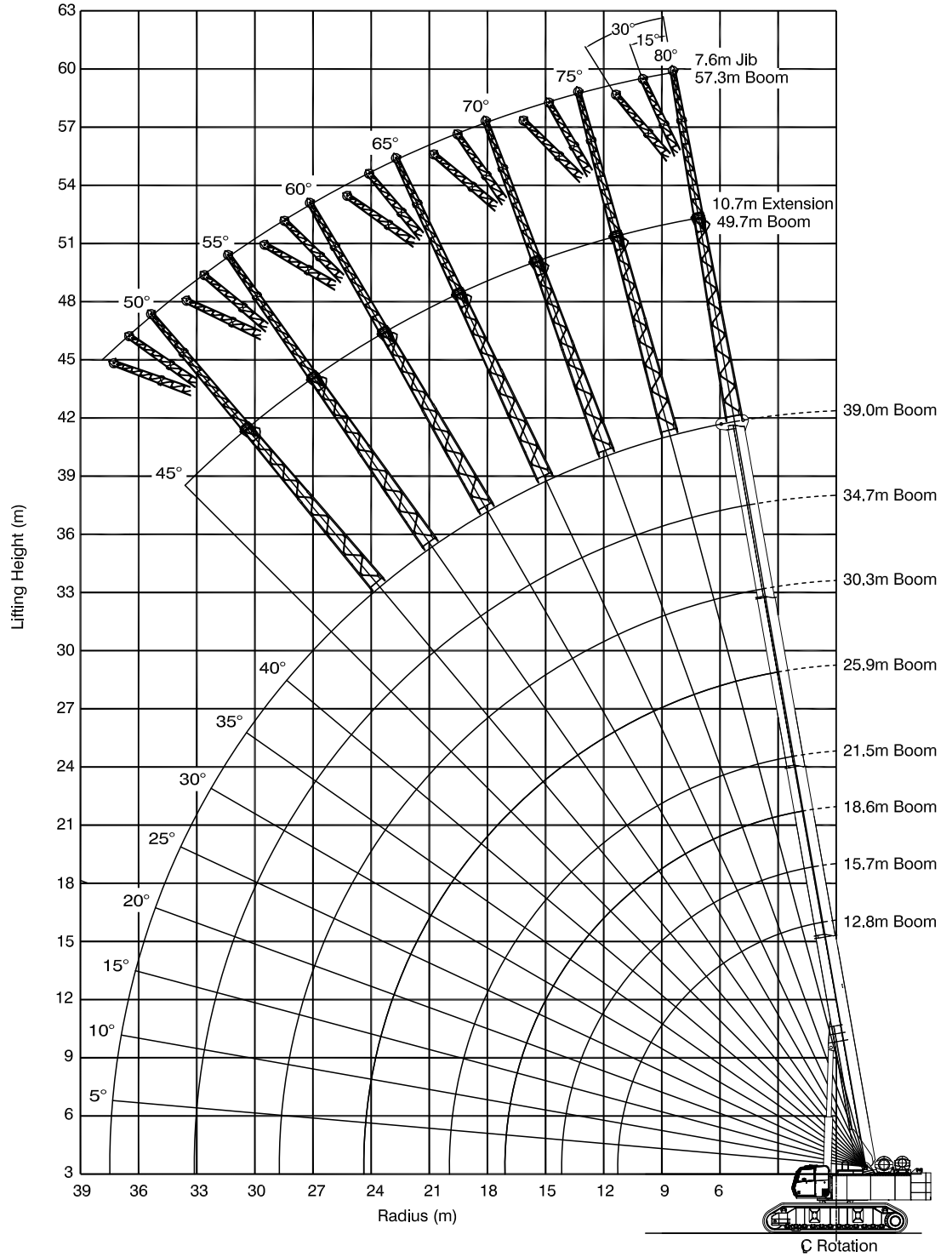
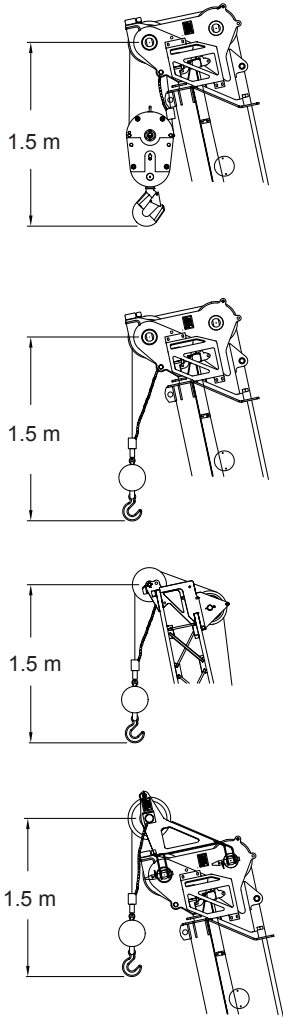

LIFTING CAPACITIES LOADS IN METRIC TON

MAIN BOOM with TRACKS FULLY EXTENDED

RADIUS (m)	MAIN BOOM LENGTH								MAIN BOOM LENGTH								MAIN BOOM LENGTH								RADIUS (m)	
	12,8	15,7	18,6	21,5	25,9	30,3	34,7	39,0	12,8	15,7	18,6	21,5	25,9	30,3	34,7	39,0	12,8	15,7	18,6	21,5	25,9	30,3	34,7	39,0		
2,5	100								100								100								2,5	
3,0	90,7	63,5	54,4	43,5					90,7	63,5	54,4	43,5					90,7	63,5	54,4	43,5					3,0	
3,5	81,3	60,8	50,7	40,2					81,3	60,8	50,7	40,2					81,3	60,8	50,7	40,2					3,5	
4,0	75,1	57,8	47,1	37,1	30,7				75,1	57,8	47,1	37,1	30,7				75,1	57,8	47,1	37,1	30,7				4,0	
4,5	70,9	54,9	43,6	34,4	29,2	22,8			70,9	54,9	43,6	34,4	29,2	22,8			70,9	54,9	43,6	34,4	29,2	22,8			4,5	
5,0	67,0	51,9	40,9	32,2	27,6	22,3			66,5	51,9	40,9	32,2	27,6	22,3			63,1	51,9	40,9	32,2	27,6	22,3			5,0	
6,0	59,3	45,9	35,9	28,1	24,4	21,4	20,0	18,0	57,6	45,9	35,9	28,1	24,4	21,4	20,0	18,0	47,1	45,9	35,9	28,1	24,4	21,4	20,0	18,0	6,0	
7,0	54,0	42,7	33,2	26,1	22,2	20,5	19,6	17,5	47,1	42,3	33,2	26,1	22,2	20,5	19,6	17,5	37,1	36,8	32,6	26,1	22,2	20,5	19,6	17,5	7,0	
8,0	47,2	39,6	30,8	24,3	20,5	19,7	18,6	16,7	37,7	37,3	30,8	24,3	20,5	19,7	18,6	16,7	29,0	28,7	28,4	24,1	20,5	19,7	18,6	16,7	8,0	
9,0	37,5	36,3	28,5	22,5	19,6	18,9	17,4	16,0	30,0	29,6	28,5	22,5	19,6	18,9	17,4	16,0	23,2	22,8	22,6	22,0	19,6	18,9	17,4	16,0	9,0	
10,0	32,4	32,1	26,1	20,4	18,1	17,3	16,1	15,2	25,0	24,6	24,3	20,4	18,1	17,3	16,1	15,2	19,0	18,9	18,9	18,9	18,0	17,3	16,1	15,2	10,0	
12,0		22,3	21,5	17,1	16,0	15,6	13,8	13,4		17,6	17,5	17,0	16,0	15,6	13,8	13,4		12,9	12,7	12,5	13,3	13,9	13,8	13,4	12,0	
14,0		17,0	16,5	15,5	14,8	13,6	12,3	12,0		13,6	13,1	12,9	13,3	13,4	12,3	12,0		9,2	8,7	8,6	9,3	10,1	10,7	11,4	14,0	
16,0			12,7	12,6	12,9	11,7	10,9	10,4			9,9	9,7	10,1	10,4	10,5	10,4			6,4	6,3	6,9	7,6	8,0	8,4	16,0	
18,0				9,8	10,4	10,5	9,7	9,0				7,5	8,1	8,7	8,8	9,0				4,8	5,3	5,9	6,3	6,6	18,0	
20,0				8,0	8,6	9,3	8,5	8,0				5,9	6,5	7,2	7,3	7,5				3,8	4,1	4,6	4,9	5,3	20,0	
22,0					7,4	7,9	7,6	7,0					5,3	5,8	6,2	6,5					3,1	3,5	3,9	4,3	22,0	
24,0					6,1	6,6	6,8	6,4					4,2	4,7	5,1	5,5					2,2	2,6	3,0	3,3	24,0	
26,0						5,5	5,9	5,7						3,8	4,2	4,6					1,9	2,2	2,5	2,5	26,0	
28,0						4,7	5,0	5,2						3,2	3,5	3,8						1,4	1,6	1,8	28,0	
30,0							4,3	4,4							2,8	3,0							1,1	1,3	30,0	
32,0								3,6	3,8							2,2	2,4							NR	NR	32,0
34,0									3,3							2,0									NR	34,0
36,0									2,8							1,6									NR	36,0

NOTE: Capacities appearing above the bold line are based on structural strength; tipping should not be relied upon as a capacity limitation. Capacities appearing below the bold line are based on stability and do not exceed 75% of tipping.



LIFTING CAPACITIES LOADS IN METRIC TON

AUXILIARY BOOM NOSE SHEAVE with TRACKS FULLY EXTENDED																												
																								RADIUS (m)				
RADIUS (m)	MAIN BOOM LENGTH								MAIN BOOM LENGTH								MAIN BOOM LENGTH								RADIUS (m)			
	12,8	15,7	18,6	21,5	25,9	30,3	34,7	39,0	12,8	15,7	18,6	21,5	25,9	30,3	34,7	39,0	12,8	15,7	18,6	21,5	25,9	30,3	34,7	39,0				
3,0	8,2	8,2	8,2	8,2					8,2	8,2	8,2	8,2					8,2	8,2	8,2	8,2							3,0	
3,5	8,2	8,2	8,2	8,2					8,2	8,2	8,2	8,2					8,2	8,2	8,2	8,2							3,5	
4,0	8,2	8,2	8,2	8,2	8,2				8,2	8,2	8,2	8,2	8,2				8,2	8,2	8,2	8,2	8,2						4,0	
4,5	8,2	8,2	8,2	8,2	8,2	8,2			8,2	8,2	8,2	8,2	8,2	8,2			8,2	8,2	8,2	8,2	8,2	8,2					4,5	
5,0	8,2	8,2	8,2	8,2	8,2	8,2			8,2	8,2	8,2	8,2	8,2	8,2			8,2	8,2	8,2	8,2	8,2	8,2					5,0	
6,0	8,2	8,2	8,2	8,2	8,2	8,2	8,2	8,2	8,2	8,2	8,2	8,2	8,2	8,2	8,2	8,2	8,2	8,2	8,2	8,2	8,2	8,2	8,2	8,2	8,2	8,2	6,0	
7,0	8,2	8,2	8,2	8,2	8,2	8,2	8,2	8,2	8,2	8,2	8,2	8,2	8,2	8,2	8,2	8,2	8,2	8,2	8,2	8,2	8,2	8,2	8,2	8,2	8,2	8,2	7,0	
8,0	8,2	8,2	8,2	8,2	8,2	8,2	8,2	8,2	8,2	8,2	8,2	8,2	8,2	8,2	8,2	8,2	8,2	8,2	8,2	8,2	8,2	8,2	8,2	8,2	8,2	8,2	8,0	
9,0	8,2	8,2	8,2	8,2	8,2	8,2	8,2	8,2	8,2	8,2	8,2	8,2	8,2	8,2	8,2	8,2	8,2	8,2	8,2	8,2	8,2	8,2	8,2	8,2	8,2	8,2	9,0	
10,0	8,2	8,2	8,2	8,2	8,2	8,2	8,2	8,2	8,2	8,2	8,2	8,2	8,2	8,2	8,2	8,2	8,2	8,2	8,2	8,2	8,2	8,2	8,2	8,2	8,2	8,2	10,0	
12,0		8,2	8,2	8,2	8,2	8,2	8,2	8,2		8,2	8,2	8,2	8,2	8,2	8,2	8,2		8,2	8,2	8,2	8,2	8,2	8,2	8,2	8,2	8,2	12,0	
14,0		8,2	8,2	8,2	8,2	8,2	8,2	8,2		8,2	8,2	8,2	8,2	8,2	8,2	8,2		8,2	8,2	8,2	8,2	8,2	8,2	8,2	8,2	8,2	14,0	
16,0			8,2	8,2	8,2	8,2	8,2	8,2			8,2	8,2	8,2	8,2	8,2	8,2			6,3	6,1	6,8	7,5	7,6	8,2			16,0	
18,0				8,2	8,2	8,2	8,2	8,2				7,4	7,9	8,2	8,2	8,2				4,6	5,2	5,8	6,1	6,5			18,0	
20,0				7,9	8,2	8,2	8,2	8,0				5,8	6,4	7,0	7,2	7,4				3,7	4,0	4,4	4,8	5,2			20,0	
22,0					7,3	7,7	7,5	7,0					5,2	5,7	6,0	6,4					3,0	3,4	3,7	4,1			22,0	
24,0					6,0	6,5	6,6	6,4					4,1	4,6	5,0	5,4					2,1	2,5	2,8	3,2			24,0	
26,0						5,4	5,8	5,7						3,7	4,0	4,5						1,7	2,1	2,4			26,0	
28,0						4,6	4,9	5,0							3,3	3,6						1,2	1,4	1,7			28,0	
30,0							4,1	4,3							2,7	2,9							1,0	1,2			30,0	
32,0								3,4	3,7							2,1	2,3							NR	NR			32,0
34,0									3,1								1,9								NR			34,0
36,0										2,7								1,5								NR		36,0

NOTE: Capacities appearing above the bold line are based on structural strength; tipping should not be relied upon as a capacity limitation. Capacities appearing below the bold line are based on stability and do not exceed 75% of tipping.

LIFTING CAPACITIES LOADS IN METRIC TON

MAIN BOOM with TRACKS RETRACTED									
RAD. (m)	MAIN BOOM LENGTH								
	12,8	15,7	18,6	21,5	25,9	30,3	34,7	39,0	
2,5	100								
3,0	90,7	63,5	54,4	43,5					
3,5	80,3	60,8	50,7	40,2					
4,0	69,1	57,8	47,1	37,1	30,7				
4,5	58,1	54,9	43,6	34,4	29,2	22,8			
5,0	51,0	49,2	40,9	32,2	27,6	22,3			
6,0	37,9	37,0	35,9	28,1	24,4	21,4	20,0	18,0	
7,0	31,0	30,4	30,0	26,1	22,2	20,5	19,6	17,5	
8,0	25,3	24,8	24,5	23,4	20,5	19,7	18,6	16,7	
9,0	20,3	20,0	19,9	19,2	19,6	18,9	17,4	16,0	
10,0	16,5	16,2	16,0	15,5	16,2	17,3	16,1	15,2	
12,0		12,0	11,8	11,4	12,0	12,8	13,8	13,4	
14,0		9,0	8,8	8,5	9,1	9,8	10,1	11,6	
16,0			6,6	6,3	7,0	7,6	8,0	8,3	
18,0				4,8	5,4	5,9	6,3	6,5	
20,0				3,6	4,2	4,7	5,0	5,3	
22,0					3,4	3,7	4,0	4,3	
24,0					2,6	2,9	3,2	3,5	
26,0						2,3	2,6	2,7	
28,0						1,7	1,9	2,1	
30,0							1,4	1,6	
32,0							1,0	1,2	
34,0								NR	
36,0								NR	

AUXILIARY NOSE SHEAVE with TRACKS RETRACTED									
RAD. (m)	MAIN BOOM LENGTH								
	12,8	15,7	18,6	21,5	25,9	30,3	34,7	39,0	
3,0	8,2	8,2	8,2	8,2					
3,5	8,2	8,2	8,2	8,2					
4,0	8,2	8,2	8,2	8,2	8,2				
4,5	8,2	8,2	8,2	8,2	8,2	8,2			
5,0	8,2	8,2	8,2	8,2	8,2	8,2			
6,0	8,2	8,2	8,2	8,2	8,2	8,2	8,2	8,2	
7,0	8,2	8,2	8,2	8,2	8,2	8,2	8,2	8,2	
8,0	8,2	8,2	8,2	8,2	8,2	8,2	8,2	8,2	
9,0	8,2	8,2	8,2	8,2	8,2	8,2	8,2	8,2	
10,0	8,2	8,2	8,2	8,2	8,2	8,2	8,2	8,2	
12,0		8,2	8,2	8,2	8,2	8,2	8,2	8,2	
14,0			8,0	7,9	8,0	8,2	8,2	8,2	
16,0			6,4	6,2	6,8	7,5	7,6	7,8	
18,0				4,6	5,2	5,8	6,1	6,4	
20,0				3,5	4,0	4,5	4,8	5,2	
22,0					3,2	3,6	3,9	4,1	
24,0					2,5	2,8	3,1	3,3	
26,0						2,2	2,4	2,6	
28,0						1,6	1,8	2,0	
30,0							1,3	1,5	
32,0							NR	NR	
34,0								NR	
36,0								NR	

10,7m EXTENSION & 7.6m JIB					
Boom Angle	10,7m EXTENSION		7,6m JIB		
	Total Boom Length		Jib Offset Angles		
	23,5-45,7m	>45,7m			
			0°	15°	30°
80°	11,3	11,3	5,4	3,3	1,8
78°	8,6	8,6	5,3	3,1	1,7
75°	7,3	7,3	4,6	2,9	1,6
72°	6,4	6,4	4,2	2,6	1,6
70°	5,6	5,6	3,8	2,5	1,5
68°	5,0	5,0	3,4	2,3	1,5
65°	4,5	4,5	3,2	2,1	1,4
62°	4,2	4,2	2,9	2,0	1,4
60°	3,9	3,9	2,6	1,6	1,1
58°	3,7	3,7	2,1	1,1	0,8
55°	3,4	3,4	1,6	0,5	0,3
52°	3,2	3,2	1,1	0,2	0,2
50°	3,1	3,1	0,9	0,2	0,1
48°	2,9	2,8			
45°	2,7	2,3			

Weight Reductions for Load Handling Devices	
Hookblocks	
100 t - 5 Sheave	1,176 kg
90.7 t - 5 Sheave	1,134 kg
10.9 t Overhaul Ball w/Swivel	265 kg
Optional Load Handling Devices	
10.7m Extension - Stowed*	130 kg
10.7m Extension - Erected*	1,867 kg
10.7m Ext. and 7.6m Jib - Stowed*	127 kg
10.7m Ext. and 7.6m Jib - Erected*	3,012 kg
Auxiliary Nose Sheave*	114 kg
Auger Ready Package*	90 kg
Auger Package Complete - Stowed*	205 kg
Auger Package Complete - Erected*	508 kg

*Reduction of main boom capacities

NOTE: Capacities appearing above the bold line are based on structural strength; tipping should not be relied upon as a capacity limitation. Capacities appearing below the bold line are based on stability and do not exceed 75% of tipping.



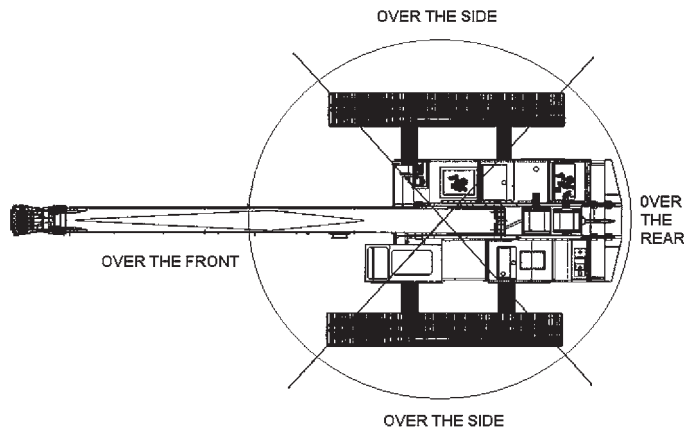

GTC-1000EX				
WIRE ROPE LINE PULL CAPACITIES				
PARTS OF LINE	MAIN WINCH (kN)	AUX WINCH (kN)	PARTS OF LINE	MAIN WINCH (kN)
1	101	83	6	607
2	202	166	7	708
3	303	N/A	8	809
4	405	N/A	9	910
5	506	N/A	10	1011

22mm diameter wire rope, 6 x 37 Class, EIP, IWRC

PLEASE READ, UNDERSTAND, AND FOLLOW THE MANUALS FURNISHED WITH THE CRANE (OPERATOR'S AND SAFETY) AS WELL AS THE CAPACITY LIMITATIONS AND GENERAL CONDITIONS LISTED BELOW PRIOR TO OPERATION OF THE CRANE. FAILURE TO DO SO MAY RESULT IN AN ACCIDENT.

Capacity Limitations and General Conditions:

- This TADANO MANTIS CRANE as manufactured, meets the requirements of ANSI B30.5. Structure and stability have been tested in accordance with SAE J1063 and SAE J765, respectively. Modifications to the crane or use of optional equipment other than specified by the manufacturer can result in a reduction of capacity.
- The main boom and auxiliary boom head lifting capacities are determined by boom length and load radius. The extension and jib lifting capacities are determined by boom angle.
- Rated capacity loads given are maximum covered by the manufacturer's warranty and are based on a freely suspended load with NO allowance for factors such as out-of-level operation, supporting surface conditions, hazardous surroundings, experience of personnel, etc. The operator shall establish practical working loads based on prevailing operating conditions, such as, but not limited to the above.
- All rated capacity loads shown apply to original equipment as supplied by Tadano Mantis Corporation
- All rated capacity loads appearing above the bold line are based on structural strength; tipping should not be relied upon as a capacity limitation.
- All rated capacity loads appearing below the bold line are based on stability and do not exceed 75% of tipping.
- Deductions from rated capacities must be made for the weight of the hook block, headache ball, slings, spreader bar, and any other suspended equipment. See Lifting Capacity Deduction Chart for load handling devices supplied by Tadano Mantis Corporation
- A properly calibrated and maintained Load Moment Indicator (LMI) system will indicate boom mounted and other suspended equipment.
- When making lifts where capacities may be within a zone limited by structural strength, the operator shall determine that the weight of the load is known within plus or minus (+/-) ten percent (10%) before making lift.
- It is permissible to attempt to telescope boom with a load within the limits of rated capacities. However, boom telescope system hydraulic pressure, and/or boom lubrication may affect operation.
- Side pull on boom is extremely dangerous and must be avoided.
- DO NOT** exceed manufacturers maximum specified reeving.
- DO NOT** lift load or extend boom without proper configuration of crane per load chart selected.
- DO NOT** attempt to lift any load when wind speed exceeds 32,2 km/h.

Load moment indicating and anti-two block systems are operator aids and must never be used in lieu of job site lift planning calculations by the operator which must take into account ground conditions, weather and all other environmental factors prevailing at the time of the lift.

Prices and specifications are subject to change at any time without prior notice and are for factory installation at the time of original manufacture. F.O.B Plant; Richlands, VA 24641. Illustrations and photographs may show optional equipment. Supersedes all previous issues.

Please see www.mantiscranes.com for most current information.

Load Chart Symbol Key

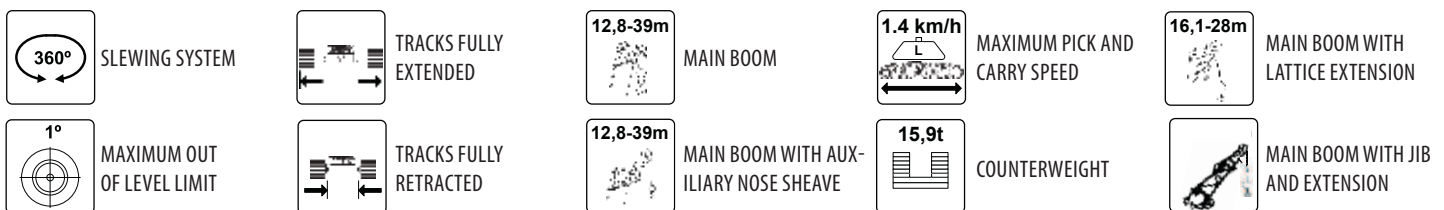

CAUTION

⚠ THESE CHART VALUES ARE ONLY A GUIDE AND MUST NOT BE USED TO OPERATE THE CRANE. USE ONLY THE IN CAB LOAD CHARTS AND OPERATOR'S MANUAL FURNISHED WITH THE CRANE. ⚠

TADANO MANTIS CORPORATION

1705 Columbia Avenue • Franklin, TN 37064 USA • Toll-Free: 1-800-272-3325 • Fax: 615-790-6803 • mantiscranes.com

TADANO Ltd., International Division

4-12, Kamezawa 2-chome,
Sumida-Ku, Tokyo 130-0014, Japan

Tel: +81 3 3621 7750

Fax: +81 3 3621 7785

E-mail: tdnihq@tadano.co.jp

www.tadano.co.jp/indexe.html

GTC-300EX

27t Telescopic Boom Crawler Crane

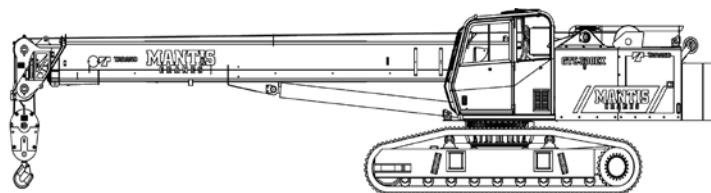

GTC-400EX

40t Telescopic Boom Crawler Crane

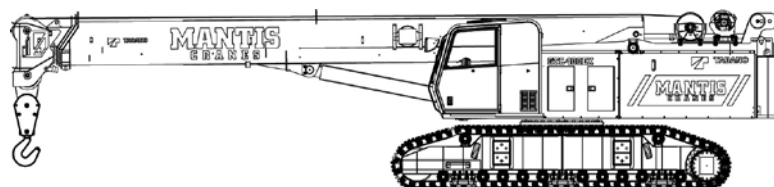

GTC-700EX

70t Telescopic Boom Crawler Crane

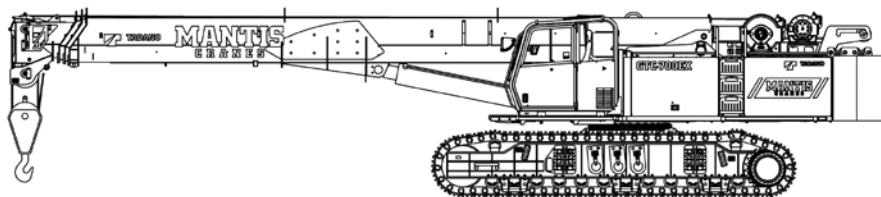

GTC-1000EX

100t Telescopic Boom Crawler Crane

