

# Product advantages

## Mobile crane LTM 1030/2



**Max. lifting capacity: 35 t at 3 m radius**

**Max. height under hook: 45 m with biparted swing-away jib**

**Max. radius: 40 m with biparted swing-away jib**



### Performance profile of the LTM 1030/2 at a glance.

- 24 t total weight, incl. 2.5 t counterweight, 15 m biparted swing-away jib, 14-size tyres, and 21.7 t hook block (axle load 2 x 12 t)
- Outstanding range of lifting capacities, counterweight variants 5.5 t and 2.5 t
- Modern 205 kW/278 h.p. Mercedes-Benz 6-cylinder in-line Diesel engine with exhaust gas turbo-charger and charge cooling (EURO II), fully electronic engine management
- Liebherr-System-Bus (LSB) for data transfer, e.g. for the engine and transmission management as well as for the vehicle electric system
- Compact and manoeuvrable due to all-wheel drive and all-wheel steering, smallest turning radius 6,3 m across vehicle
- Travelling control and setting on outriggers from crane cab - standard features
- Load-sensing system for optimized crane control
- 4-section telescopic boom of maximum stability, length 9.2 m - 30 m, and 8.6 - 15 m long biparted swing-away jib for heights under hook of up to 45 m and radii of up to 40 m
- LICCON, the most modern crane computer system world-wide, with comprehensive informative, monitoring and control functions
- Slewing rim, slewing gear, winch and hydraulic pump are self-manufactured, quality checked components
- Quality assurance system according to DIN ISO 9001

# LIEBHERR

The better crane.



## Torsional rigid telescopic boom.

- Oviform cross-sectional boom profile, multi-folded design, buckling-proof and torsional rigid, of excellent guiding quality
- Maintenance-free polyamide slide pads of telescopes
- First-rate lifting capacities, e.g.
  - 8.0 t at 10 m radius
  - 3.1 t at 10 m radius, free on wheels
  - 2.9 t at 20 m radius
  - 1.4 t at 30 m radius
  - 0.5 t at 40 m radius

## Wide comfortable driving cab.

- Two-seated comfortable driving cab, corrosion-proof structural steel design, dip-primed and entirely powder-coated, front section mounted on rubber shock absorbers, rear section on hydraulic dampers
- Safety glass all around
- Air-cushioned driver's seat with pneumatic lumbar support, co-driver's seat air-cushioned
- Steering wheel adjustable in height and inclination, heatable and electrically adjustable exterior mirrors
- Standardized and ergonomically located operating and control elements, equally for the „Niveaumatik“ suspension

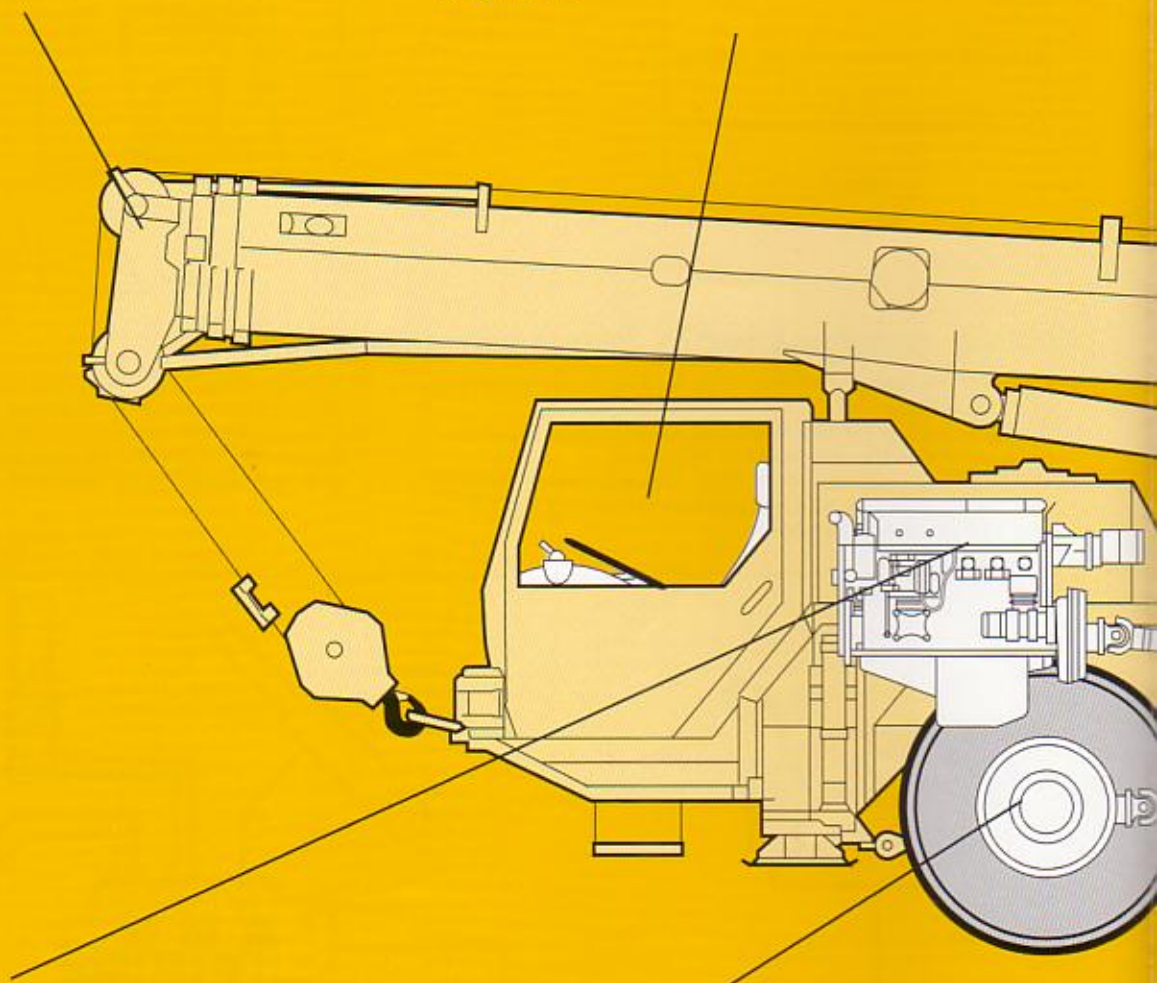

## Modern and powerful carrier drive.

- Water-cooled Mercedes-Benz 6-cylinder in-line Diesel engine with exhaust gas turbo-charger and charge cooling (EURO II), with fully electronic engine management
- ZF power shift gear type 6 WG 210 with torque converter and automatic control and electronic engine management, 6 forward, 2 reverse speeds and rough-terrain ratio
- Max. driving speed 80 km/h, max. gradability 60 %
- Liebherr axial piston variable displacement pump controlled by the power shift gear, activatable for the crane drive

## Outstanding carrier technology for on-road and off-road application.

- Weight-optimized axles, almost maintenance-free, made of high-tensile steel, perfect track keeping and lateral stability due to special control linkage arrangement
- Drive 4 x 4, only the rear axle is driven for on-road displacement, front axle activatable for off-road operation
- All-wheel steering, rear axle also steerable independent of front axle (crab steering)
- The cardan shafts only require minor maintenance and are safely located within the axle body; 70° diagonal toothing enables simple and fast fitting by a few screws

ring by Liebherr.



## Spacious crane cab with armrest-integrated control levers.

- Galvanized crane cab, tinted panes all around, front knockout window with large parallel windscreen wiper, large skylight of bullet-proof glass with large segmental windscreen wiper and roller blind, space saving sliding door
- Operator's seat with pneumatic lumbar support and headrest
- Convenient armrest-integrated control elements, vertically adjustable master switch consoles and armrests, ergonomically inclined operating consoles
- Steering operation by means of flip switch
- Sound and heat insulated internal panelling, an auxiliary heating is part of the standard equipment
- LICCON computer system with monitor

## Liebherr components - reliable and easy-to-service.

- Slewing rim, slewing gear, winch and axial piston variable displacement pump are self-produced Liebherr components, specially matched for the application in mobile cranes
- Centralized lubricating system for slewing rim, boom bearing application and bearings of winches and luffing ram

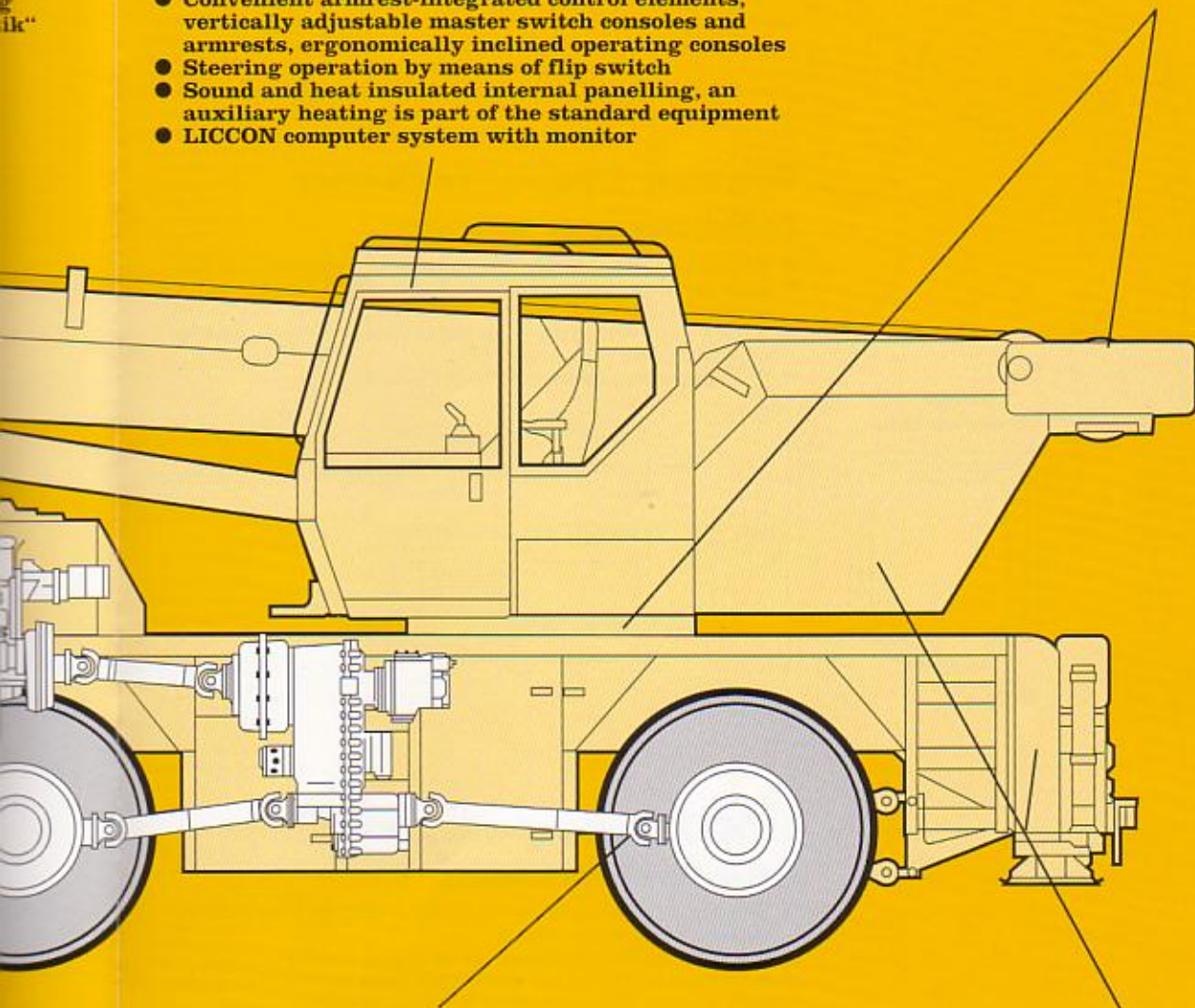

## Niveaumatik suspension - preserving crane and roads.

- Maintenance-free suspension rams, free from lateral forces, protected by synthetic tubes
- Level position (suspension on „travelling mode“) can be activated automatically by push-button control from any position
- Stable cornering ability due to cross mounting of the hydropneumatic suspension
- Axle locking system (locking of suspension for travelling with load) controlled from the driving cab

## Weight-optimized steel structure.

- Carrier, superstructure and telescopic boom in light-gauge design, calculated by the FEM method, weight-optimized and of maximum torsional rigidity
- Tensile property of material with high safety factors through the application of STE 960 (960 N/mm<sup>2</sup>) for all supporting members such as telescopic boom, superstructure frame and outrigger system



## Handling of loads - precise and safe.

- 4-section, 30 m long telescopic boom and 8.6 m - 15 m long biparted swing-away jib for 45 m height under hook and 40 m radius
- The LICCON system calculates the optimal load curve at any boom length
- Swing-away jib mountable at 0°, 20° or 40°
- Hydraulic rigging aid for swing-away jib

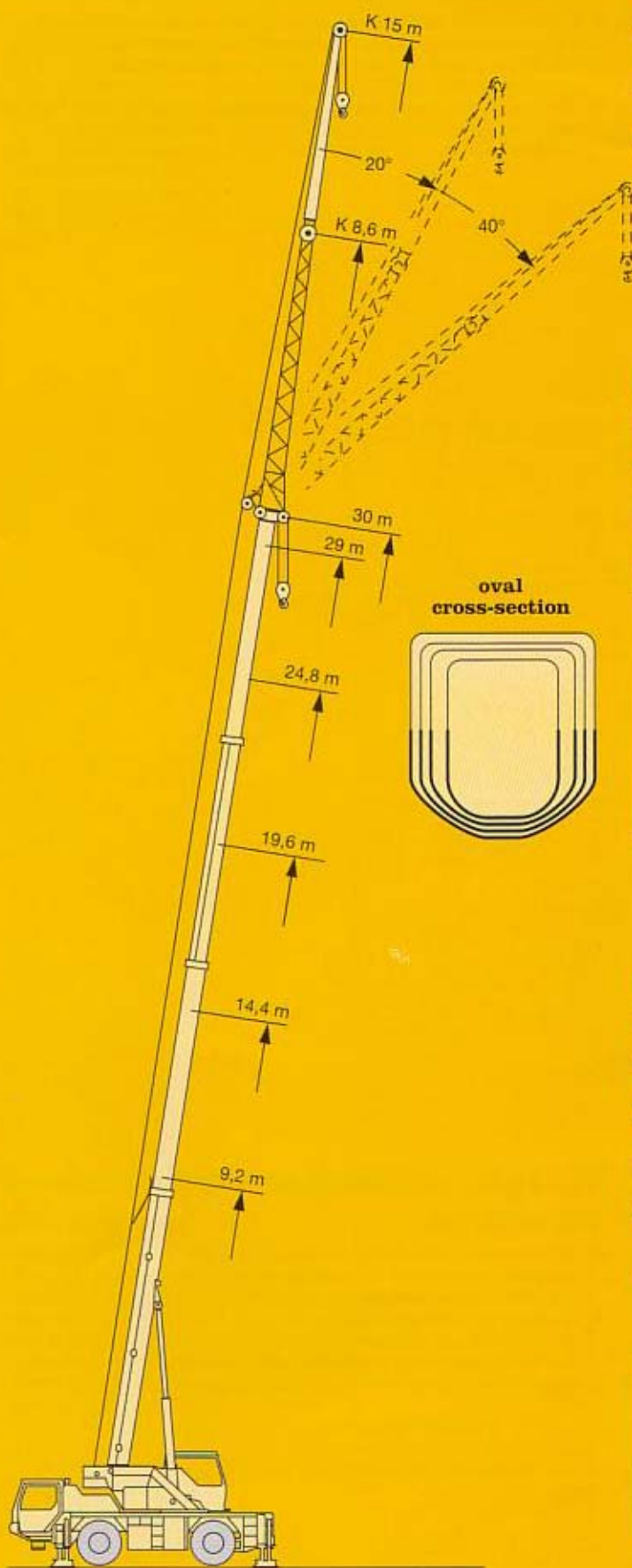

## Proved hydromechanic telescoping system.

- Reliable, single-stage, double-acting hydraulic ram
- Low gravity center of boom due to twin block and tackle for 2nd and 4th boom step
- Telescopes equipped with wear-resistant polyamide bearing pads
- Oviform cross-sectional boom profile

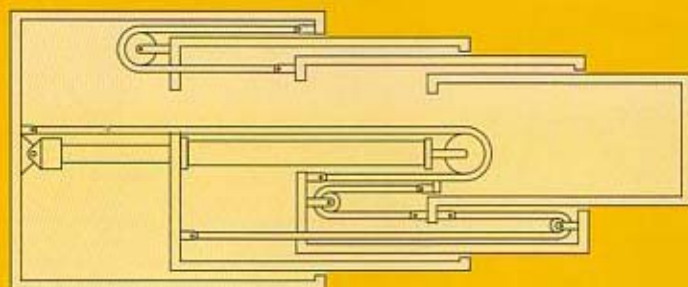

## LICCON computer with SLI and test system.

- Setting of crane configuration by convenient conversational-mode functions
- Reliable acknowledgement of crane configuration set
- Representation of all essential data by graphic symbols within the operation image
- Reliable cut-off device when exceeding the permissible load moments
- Safe load values for any boom intermediate length
- Winch indications for load hook course with zero adjuster for ultra-precise lifting/lowering
- Test system for servicing including facility to check all sensors and consumers connected to the system on the display screen

