



An Oshkosh Corporation Company

Operation and Safety Manual

Original Instructions - Keep this manual with the machine at all times.

Boom Lift Models

600A

600AJ



3121204
August 25, 2010

ADE Identification

All 600A and 600AJ machines from S/N 64249 incorporate ADE. The following machine serial numbers prior to S/N 64249 also utilize ADE: 63908, 63912, 63932, 63936, 63938, 63954, 63959, and 63963.

A Machine that incorporates ADE (Advanced Design Electronics) can be outwardly identified by the analyzer connection at the base of the platform control box as shown by the arrow.



FOREWORD

This manual is a very important tool! Keep it with the machine at all times.

The purpose of this manual is to provide owners, users, operators, lessors, and lessees with the precautions and operating procedures essential for the safe and proper machine operation for its intended purpose.

Due to continuous product improvements, JLG Industries, Inc. reserves the right to make specification changes without prior notification. Contact JLG Industries, Inc. for updated information.

SAFETY ALERT SYMBOLS AND SAFETY SIGNAL WORDS



This is the Safety Alert Symbol. It is used to alert you to the potential personal injury hazards. Obey all safety messages that follow this symbol to avoid possible injury or death

DANGER

INDICATES AN IMMINENTLY HAZARDOUS SITUATION. IF NOT AVOIDED, WILL RESULT IN SERIOUS INJURY OR DEATH. THIS DECAL WILL HAVE A RED BACKGROUND.

WARNING

INDICATES A POTENTIALLY HAZARDOUS SITUATION. IF NOT AVOIDED, COULD RESULT IN SERIOUS INJURY OR DEATH. THIS DECAL WILL HAVE AN ORANGE BACKGROUND.

CAUTION

INDICATES A POTENTIALLY HAZARDOUS SITUATION. IF NOT AVOIDED, MAY RESULT IN MINOR OR MODERATE INJURY. IT MAY ALSO ALERT AGAINST UNSAFE PRACTICES. THIS DECAL WILL HAVE A YELLOW BACKGROUND.

⚠ WARNING

THIS PRODUCT MUST COMPLY WITH ALL SAFETY RELATED BULLETINS. CONTACT JLG INDUSTRIES, INC. OR THE LOCAL AUTHORIZED JLG REPRESENTATIVE FOR INFORMATION REGARDING SAFETY-RELATED BULLETINS WHICH MAY HAVE BEEN ISSUED FOR THIS PRODUCT.

NOTICE

JLG INDUSTRIES, INC. SENDS SAFETY RELATED BULLETINS TO THE OWNER OF RECORD OF THIS MACHINE. CONTACT JLG INDUSTRIES, INC. TO ENSURE THAT THE CURRENT OWNER RECORDS ARE UPDATED AND ACCURATE.

NOTICE

JLG INDUSTRIES, INC. MUST BE NOTIFIED IMMEDIATELY IN ALL INSTANCES WHERE JLG PRODUCTS HAVE BEEN INVOLVED IN AN ACCIDENT INVOLVING BODILY INJURY OR DEATH OF PERSONNEL OR WHEN SUBSTANTIAL DAMAGE HAS OCCURRED TO PERSONAL PROPERTY OR THE JLG PRODUCT.

For:

- Accident Reporting
- Product Safety Publications
- Current Owner Updates
- Questions Regarding Product Safety
- Standards and Regulations Compliance Information
- Questions Regarding Special Product Applications
- Questions Regarding Product Modifications

Contact:

Product Safety and Reliability Department
JLG Industries, Inc.
13224 Fountainhead Plaza
Hagerstown, MD 21742

or Your Local JLG Office
(See addresses on inside of manual cover)

In USA:

Toll Free: 877-JLG-SAFE (877-554-7233)

Outside USA:

Phone: 240-420-2661
Fax: 301-745-3713
E-mail: ProductSafety@JLG.com

REVISION LOG

Original Issue	- April 1, 2005
Revised	- October 6, 2005
Revised	- February 27, 2006
Revised	- May 8, 2006
Revised	- February 22, 2008
Revised	- January 1, 2009
Revised	- September 17, 2009
Revised	- November 25, 2009
Revised	- July 22, 2010
Revised	- August 25, 2010

SECTION - PARAGRAPH, SUBJECT	PAGE
SECTION - 1 - SAFETY PRECAUTIONS	
1.1 GENERAL	1-1
1.2 PRE-OPERATION	1-1
Operator Training and Knowledge	1-1
Workplace Inspection	1-2
Machine Inspection	1-2
1.3 OPERATION	1-3
General	1-3
Trip and Fall Hazards	1-3
Electrocution Hazards	1-4
Tipping Hazards	1-6
Crushing and Collision Hazards	1-7
1.4 TOWING, LIFTING, AND HAULING	1-8
1.5 ADDITIONAL HAZARDS / SAFETY	1-9
SECTION - 2 - USER RESPONSIBILITIES, MACHINE PREPARATION, AND INSPECTION	
2.1 PERSONNEL TRAINING	2-1
Operator Training	2-1
Training Supervision	2-1
Operator Responsibility	2-1
2.2 PREPARATION, INSPECTION, AND MAINTENANCE	2-2
Pre-Start Inspection	2-4
Function Check	2-5

SECTION - PARAGRAPH, SUBJECT	PAGE
2.3 LIMIT SWITCH FUNCTIONAL CHECK	2-5
General	2-12
SECTION - 3 - MACHINE CONTROLS AND INDICATORS	
3.1 GENERAL	3-1
3.2 CONTROLS AND INDICATORS	3-1
Ground Controls	3-2
Ground Control Indicator Panel	3-6
Platform Control	3-9
Platform Control Indicator Panel	3-15
SECTION - 4 - MACHINE OPERATION	
4.1 DESCRIPTION	4-1
4.2 OPERATING CHARACTERISTICS AND LIMITATIONS	4-1
Capacities	4-1
Stability	4-2
4.3 ENGINE OPERATION	4-2
Starting Procedure	4-2
Shutdown Procedure	4-3
4.4 TRAVELING (DRIVING)	4-5
Traveling Forward and Reverse	4-6
4.5 STEERING	4-6
4.6 PLATFORM	4-6
Platform Level Adjustment	4-6

TABLE OF CONTENTS

SECTION - PARAGRAPH, SUBJECT	PAGE	SECTION - PARAGRAPH, SUBJECT	PAGE
Platform Rotation	4-6	4.16 TIE DOWN AND LIFTING	4-20
4.7 BOOM	4-8	SECTION - 5 - EMERGENCY PROCEDURES	
Swinging the Boom	4-8	5.1 GENERAL	5-1
Raising and Lowering the Tower Boom	4-9	5.2 INCIDENT NOTIFICATION	5-1
Raising and Lowering the Main Boom	4-10	5.3 EMERGENCY OPERATION	5-1
Telescoping the Main Boom	4-10	Operator Unable to Control Machine	5-1
4.8 SHUT DOWN AND PARK	4-10	Platform or Boom Caught Overhead	5-2
4.9 OSCILLATING AXLE LOCKOUT TEST (IF EQUIPPED)	4-13	5.4 EMERGENCY TOWING PROCEDURES	5-2
4.10 STEER/TOW SELECTOR (IF EQUIPPED)	4-13	5.5 MANUAL DESCENT (MACHINES PRIOR TO S/N 70975)	5-2
4.11 TOWING (IF EQUIPPED)	4-13	SECTION - 6 - GENERAL SPECIFICATIONS & OPERATOR MAINTENANCE	
4.12 AUXILIARY POWER - NON ADE EQUIPPED MA- CHINES	4-17	6.1 INTRODUCTION	6-1
Activating from the Platform Control Station	4-17	6.2 OPERATING SPECIFICATIONS	6-2
Activating from the Ground Control Station	4-17	Capacities	6-4
4.13 AUXILIARY POWER - ADE EQUIPPED MACHINES	4-18	Engine Data	6-4
Activating from the Platform Control Station	4-18	Tires	6-8
Activating from the Ground Control Station	4-18	Dimensional Data	6-8
4.14 DUAL FUEL SYSTEM (GAS ENGINE ONLY)	4-19	Torque Requirements	6-9
Changing From Gasoline to LP Gas	4-19	Hydraulic Oil	6-9
Changing From LP Gas to Gasoline	4-19	Critical Stability Weights	6-12
4.15 RE-SYNCHRONIZE THE LOWER LIFT CYLINDER Level Override Valve	4-19	Serial Number Locations	6-12

SECTION - PARAGRAPH, SUBJECT	PAGE
6.3 OPERATOR MAINTENANCE	6-23
6.4 TIRES & WHEELS	6-32
Tire Inflation	6-32
Tire Damage	6-32
Tire Replacement	6-32
Wheel Replacement	6-33
Wheel Installation	6-33
6.5 OSCILLATING AXLE LOCKOUT TEST (IF EQUIPPED)	6-35
6.6 DRAINING OIL BUILD UP FROM THE PROPANE REG- ULATOR (PRIOR TO S/N 0300132529)	6-37
6.7 PROPANE FUEL FILTER REPLACEMENT	6-38
Removal	6-38
Installation	6-40
6.8 PROPANE FUEL SYSTEM PRESSURE RELIEF	6-40
6.9 SUPPLEMENTAL INFORMATION	6-40

SECTION - 7 - INSPECTION AND REPAIR LOG

SECTION - PARAGRAPH, SUBJECT	PAGE
LIST OF FIGURES	
2-1. Machine Nomenclature - 600AJ	2-9
2-2. Machine Nomenclature - 600A	2-10
2-3. Daily Walk-Around Inspection Diagram	2-11
2-4. Daily Walk-Around Inspection Points - Sheet 1 of 3	2-12
2-5. Daily Walk-Around Inspection Points - Sheet 2 of 3	2-13
2-6. Daily Walk-Around Inspection Points - Sheet 3 of 3	2-14
3-1. Ground Control Station	3-3
3-2. Ground Control Indicator Panel	3-6
3-3. Malfunction Indicator Light and Test Button	3-8
3-4. Platform Control Console	3-10
3-5. Platform Control Console - w/Drive Orientation	3-11
3-6. Platform Control Indicator Panel	3-16
3-7. Platform Control Indicator Panel - w/Drive Orientation	3-17
4-1. Position of Least Forward Stability	4-4
4-2. Position of Least Backward Stability	4-5
4-3. Grade and Sideslope	4-7
4-4. Boom Upright Positioning - Sheet 1 of 2	4-11
4-5. Boom Upright Positioning - Sheet 2 of 2	4-12
4-6. Towbar Connecting Points - Prior to S/N 81836	4-14
4-7. Towbar Connecting Points - S/N 81836 to	

TABLE OF CONTENTS

SECTION - PARAGRAPH, SUBJECT	PAGE	SECTION - PARAGRAPH, SUBJECT	PAGE
Present.	4-15		
4-8. Drive Disconnect Hub	4-16		
4-9. Machine Tie Down	4-21		
4-10. Lifting Chart	4-22		
4-11. 600A & 600AJ Decal Installation - Sheet 1 of 4.	4-23		
4-12. 600A & 600AJ Decal Installation - Sheet 2 of 4.	4-24		
4-13. 600A & 600AJ Decal Installation - Sheet 3 of 4.	4-25		
4-14. 600A & 600AJ Decal Installation - Sheet 4 of 4.	4-26		
6-1. Serial Number Locations	6-12		
6-2. Engine Operating Temperature Specifications - Deutz - Sheet 1 of 2	6-14		
6-3. Engine Operating Temperature Specifications - Deutz - Sheet 2 of 2	6-15		
6-4. Engine Operating Temperature Specifications - Ford - Sheet 1 of 2	6-16		
6-5. Engine Operating Temperature Specifications - Ford - Sheet 2 of 2	6-17		
6-6. Engine Operating Temperature Specifications - Caterpillar - Sheet 1 of 2	6-18		
6-7. Engine Operating Temperature Specifications - Caterpillar - Sheet 2 of 2	6-19		
6-8. Engine Operating Temperature Specifications - GM - Sheet 1 of 2	6-20		
6-9. Engine Operating Temperature Specifications - GM - Sheet 2 of 2	6-21		
6-10. Lubrication and Maintenance Point Location	6-22		
6-11. Filter Lock Assembly	6-39		

TABLE OF CONTENTS

SECTION - PARAGRAPH, SUBJECT	PAGE
LIST OF TABLES	
1-1 Minimum Approach Distances (M.A.D.)	1-5
1-2 Beaufort Scale (For Reference Only)	1-10
2-1 Inspection and Maintenance Table	2-3
4-1 600A Decal Legend - Prior to S/N 0300140401	4-27
4-2 600A Decal Legend - S/N 0300140401 to Present	4-31
4-3 600AJ Decal Legend - Prior to S/N 0300140401	4-35
4-4 600AJ Decal Legend - S/N 0300140401 to Present	4-39
6-1 Operating Specifications - Prior to S/N 0300140401	6-2
6-2 Operating Specifications - S/N 0300140401 to Present	6-3
6-3 Capacities	6-4
6-4 Continental TMD27 Specifications	6-4
6-5 Ford LRG-423 Specifications	6-5
6-6 Ford LRG-425 Specifications	6-5
6-7 Deutz F4M1011F/F4M2011 Specifications	6-6
6-8 Deutz D2011L04 Specifications	6-6
6-9 Caterpillar 3044C / 3.4	6-7
6-10 GM 3.0L	6-7
6-11 Tire Specifications	6-8
6-12 Dimensional Data	6-8
6-13 Torque Requirements	6-9
6-14 Hydraulic Oil Specifications	6-9

SECTION - PARAGRAPH, SUBJECT	PAGE
6-15 Mobilfluid 424 Specs	6-10
6-16 Mobil DTE 13M Specs	6-10
6-17 Exxon Unis HVI 26 Specs	6-11
6-18 Quintolubric 888-46	6-11
6-19 Critical Stability Weights	6-12
6-20 Lubrication Specifications	6-23
6-21 Wheel Torque Chart	6-35
7-1 Inspection and Repair Log	7-1

TABLE OF CONTENTS

SECTION - PARAGRAPH, SUBJECT

PAGE

SECTION - PARAGRAPH, SUBJECT

PAGE

This page left blank intentionally.

SECTION 1. SAFETY PRECAUTIONS

1.1 GENERAL

This section outlines the necessary precautions for proper and safe machine operation and maintenance. For proper machine use, it is mandatory that a daily routine is established based on the content of this manual. A maintenance program, using the information provided in this manual and the Service and Maintenance Manual, must also be established by a qualified person and followed to ensure the machine is safe to operate.

The owner/user/operator/lessor/lessee of the machine should not operate the machine until this manual has been read, training is accomplished, and operation of the machine has been completed under the supervision of an experienced and qualified operator.

If there are any questions with regard to safety, training, inspection, maintenance, application, and operation, please contact JLG Industries, Inc. ("JLG").

WARNING

FAILURE TO COMPLY WITH THE SAFETY PRECAUTIONS LISTED IN THIS MANUAL COULD RESULT IN MACHINE DAMAGE, PROPERTY DAMAGE, PERSONAL INJURY OR DEATH.

1.2 PRE-OPERATION

Operator Training and Knowledge

- Read and understand this manual before operating the machine.

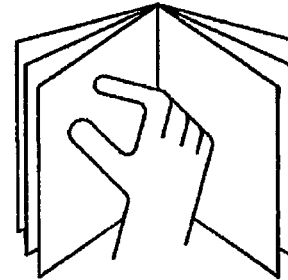

- Do not operate this machine until complete training is performed by authorized persons.
- Only authorized and qualified personnel can operate the machine.

SECTION 1 - SAFETY PRECAUTIONS

- Read, understand, and obey all DANGERS, WARNINGS, CAUTIONS, and operating instructions on the machine and in this manual.
- Use the machine in a manner which is within the scope of its intended application set by JLG.
- All operating personnel must be familiar with the emergency controls and emergency operation of the machine as specified in this manual.
- Read, understand, and obey all applicable employer, local, and governmental regulations as they pertain to operation of the machine.

Workplace Inspection

- The operator is to take safety measures to avoid all hazards in the work area prior to machine operation.
- Do not operate or raise the platform while on trucks, trailers, railway cars, floating vessels, scaffolds or other equipment unless approved in writing by JLG.
- Do not operate the machine in hazardous environments unless approved for that purpose by JLG.
- Be sure that the ground conditions are able to support the maximum load shown on the decals located on the machine.

- This machine can be operated in temperatures of 0° F to 104° F (-20° C to 40° C). Consult JLG for operation outside this range.

Machine Inspection

- Before machine operation, perform inspections and functional checks. Refer to Section 2 of this manual for detailed instructions.
- Do not operate this machine until it has been serviced and maintained according to requirements specified in the Service and Maintenance Manual.
- Be sure the footswitch and all other safety devices are operating properly. Modification of these devices is a safety violation.

WARNING

MODIFICATION OR ALTERATION OF AN AERIAL WORK PLATFORM SHALL BE MADE ONLY WITH WRITTEN PERMISSION FROM THE MANUFACTURER

- Do not operate any machine on which safety or instruction placards or decals are missing or illegible.
- Avoid any buildup of debris on the platform floor. Keep mud, oil, grease, and other slippery substances from footwear and platform floor.

1.3 OPERATION

General

- Do not use the machine for any purpose other than positioning personnel, their tools, and equipment.
 - Never operate a machine that is not working properly. If a malfunction occurs, shut down the machine.
 - Never slam a control switch or lever through neutral to an opposite direction. Always return switch to neutral and stop before moving the switch to the next function. Operate controls with slow and even pressure.
 - Do not allow personnel to tamper with or operate the machine from the ground with personnel in the platform, except in an emergency.
 - Do not carry materials directly on platform railing. Contact JLG for approved material handling accessories.
 - When two or more persons are in the platform, the operator shall be responsible for all machine operations.
 - Always ensure that power tools are properly stowed and never left hanging by their cord from the platform work area.
- Supplies or tools which extend outside the platform are prohibited unless approved by JLG.
 - When driving, always position boom over rear axle in line with the direction of travel. Remember, if boom is over the front axle, steer and drive functions will be reversed.
 - Do not assist a stuck or disabled machine by pushing, pulling, or by using boom functions. Only pull the unit from the tie-down lugs on the chassis.
 - Do not place boom or platform against any structure to steady the platform or to support the structure.
 - Stow boom and shut off all power before leaving machine.

Trip and Fall Hazards

During operation, occupants in the platform must wear a full body harness with a lanyard attached to an authorized lanyard anchorage point. Attach only one (1) lanyard per lanyard anchorage point.

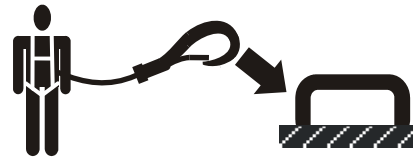

SECTION 1 - SAFETY PRECAUTIONS

- Before operating the machine, make sure all gates are closed and fastened in their proper position.

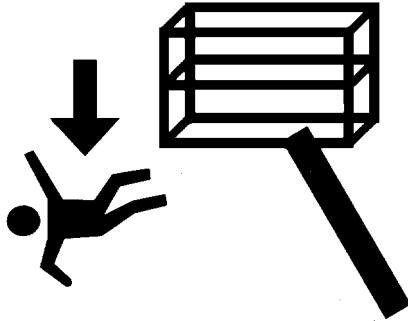

- Keep both feet firmly positioned on the platform floor at all times. Never use ladders, boxes, steps, planks, or similar items on platform to provide additional reach.
- Never use the boom assembly to enter or leave the platform.

- Use extreme caution when entering or leaving platform. Be sure that the boom is fully lowered. It may be necessary to telescope out to position the platform closer to the ground for entry/exit. Face the machine, maintain “three point contact” with the machine, using two hands and one foot or two feet and one hand during entry and exit.

Electrocution Hazards

- This machine is not insulated and does not provide protection from contact or proximity to electrical current.

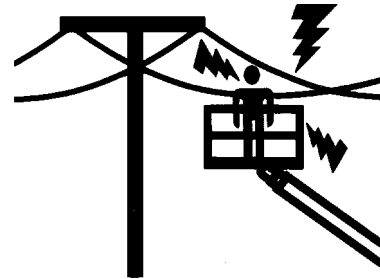

SECTION 1 - SAFETY PRECAUTIONS

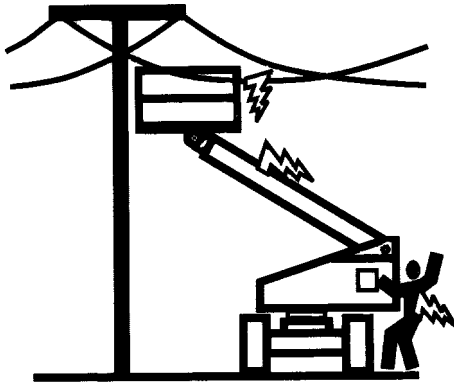

- Maintain distance from electrical lines, apparatus, or any energized (exposed or insulated) parts according to the Minimum Approach Distance (MAD) as shown in Table 1-1.
- Allow for machine movement and electrical line swaying.

Table 1-1. Minimum Approach Distances (M.A.D.)

Voltage Range (Phase to Phase)	MINIMUM APPROACH DISTANCE in Feet (Meters)
0 to 50 KV	10 (3)
Over 50KV to 200 KV	15 (5)
Over 200 KV to 350 KV	20 (6)
Over 350 KV to 500 KV	25 (8)
Over 500 KV to 750 KV	35 (11)
Over 750 KV to 1000 KV	45 (14)

NOTE: *This requirement shall apply except where employer, local or governmental regulations are more stringent.*

- Maintain a clearance of at least 10 ft. (3m) between any part of the machine and its occupants, their tools, and their equipment from any electrical line or apparatus carrying up to 50,000 volts. One foot additional clearance is required for every additional 30,000 volts or less.

SECTION 1 - SAFETY PRECAUTIONS

- The minimum approach distance may be reduced if insulating barriers are installed to prevent contact, and the barriers are rated for the voltage of the line being guarded. These barriers shall not be part of (or attached to) the machine. The minimum approach distance shall be reduced to a distance within the designed working dimensions of the insulating barrier. This determination shall be made by a qualified person in accordance with the employer, local, or governmental requirements for work practices near energized equipment

⚠ DANGER

DO NOT MANEUVER MACHINE OR PERSONNEL INSIDE PROHIBITED ZONE (MAD). ASSUME ALL ELECTRICAL PARTS AND WIRING ARE ENERGIZED UNLESS KNOWN OTHERWISE.

Tipping Hazards

- The user must be familiar with the surface before driving. Do not exceed the allowable sideslope and grade while driving.

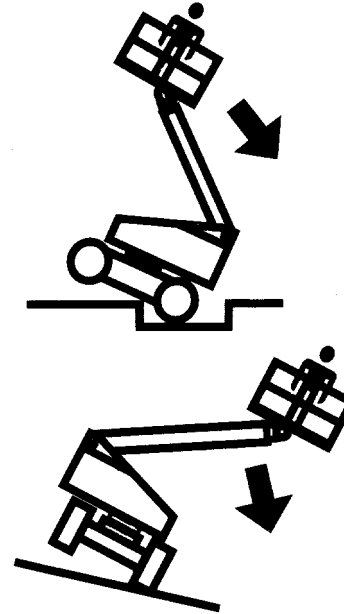

- Do not elevate platform or drive with platform elevated while on a sloping, uneven, or soft surface.
- Before driving on floors, bridges, trucks, and other surfaces, check allowable capacity of the surfaces.
- Never exceed the maximum platform capacity. Distribute loads evenly on platform floor.
- Do not raise the platform or drive from an elevated position unless the machine is on firm, level and smooth surfaces.
- Keep the chassis of the machine at least 2 ft. (0.6m) from holes, bumps, drop-offs, obstructions, debris, concealed holes, and other potential hazards on the floor/surface.
- Do not push or pull any object with the boom.
- Never attempt to use the machine as a crane. Do not tie-off machine to any adjacent structure.
- Do not operate the machine when wind conditions exceed 28 mph (12.5 m/s). Refer to Table 1-2, Beaufort Scale (For Reference Only).
- Do not increase the surface area of the platform or the load. Increase of the area exposed to the wind will decrease stability.
- Do not increase the platform size with unauthorized deck extensions or attachments.

- If boom assembly or platform is in a position that one or more wheels are off the ground, all persons must be removed before attempting to stabilize the machine. Use cranes, forklift trucks, or other appropriate equipment to stabilize machine.

Crushing and Collision Hazards

- Approved head gear must be worn by all operating and ground personnel.
- Check work area for clearances overhead, on sides, and bottom of platform when lifting or lowering platform, and driving.

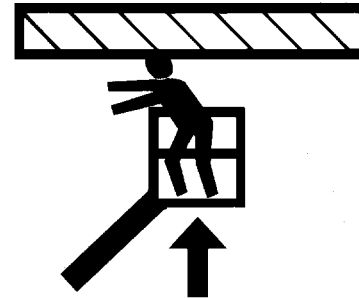

- During operation, keep all body parts inside platform railing.

SECTION 1 - SAFETY PRECAUTIONS

- Use the boom functions, not the drive function, to position the platform close to obstacles.
- Always post a lookout when driving in areas where vision is obstructed.
- Keep non-operating personnel at least 6 ft. (1.8m) away from machine during all driving and swing operations.
- Limit travel speed according to conditions of ground surface, congestion, visibility, slope, location of personnel, and other factors which may cause collision or injury to personnel.
- Be aware of stopping distances in all drive speeds. When driving in high speed, switch to low speed before stopping. Travel grades in low speed only.
- Do not use high speed drive in restricted or close quarters or when driving in reverse.
- Exercise extreme caution at all times to prevent obstacles from striking or interfering with operating controls and persons in the platform.
- Be sure that operators of other overhead and floor level machines are aware of the aerial work platform's presence. Disconnect power to overhead cranes.
- Warn personnel not to work, stand, or walk under a raised boom or platform. Position barricades on floor if necessary.

1.4 TOWING, LIFTING, AND HAULING

- Never allow personnel in platform while towing, lifting, or hauling.
- This machine should not be towed, except in the event of emergency, malfunction, power failure, or loading/unloading. Refer to the Emergency Procedures section of this manual for emergency towing procedures.
- Ensure boom is in the stowed position and the turntable locked prior to towing, lifting or hauling. The platform must be completely empty of tools.
- When lifting machine, lift only at designated areas of the machine. Lift the unit with equipment of adequate capacity.
- Refer to the Machine Operation section of this manual for lifting information.

1.5 ADDITIONAL HAZARDS / SAFETY

- Do not use machine as a ground for welding.
- When performing welding or metal cutting operations, precautions must be taken to protect the chassis from direct exposure to weld and metal cutting spatter.
- Do not refuel the machine with the engine running.
- Battery fluid is highly corrosive. Avoid contact with skin and clothing at all times.
- Charge batteries only in a well ventilated area.

SECTION 1 - SAFETY PRECAUTIONS

NOTICE

DO NOT OPERATE THE MACHINE WHEN WIND CONDITIONS EXCEED 28 MPH (12.5 M/S).

Table 1-2. Beaufort Scale (For Reference Only)

Beaufort Number	Wind Speed		Description	Land Conditions
	mph	m/s		
0	0	0-0.2	Calm	Calm. Smoke rises vertically
1	1-3	0.3-1.5	Light air	Wind motion visible in smoke
2	4-7	1.6-3.3	Light breeze	Wind felt on exposed skin. Leaves rustle
3	8-12	3.4-5.4	Gentle breeze	Leaves and smaller twigs in constant motion
4	13-18	5.5-7.9	Moderate breeze	Dust and loose paper raised. Small branches begin to move.
5	19-24	8.0-10.7	Fresh breeze	Smaller trees sway.
6	25-31	10.8-13.8	Strong breeze	Large branches in motion. Whistling heard in overhead wires. Umbrella use becomes difficult.
7	32-38	13.9-17.1	Near Gale/Moderate Gale	Whole trees in motion. Effort needed to walk against the wind.
8	39-46	17.2-20.7	Fresh Gale	Twigs broken from trees. Cars veer on road.
9	47-54	20.8-24.4	Strong Gale	Light structure damage.

SECTION 2. USER RESPONSIBILITIES, MACHINE PREPARATION, AND INSPECTION

2.1 PERSONNEL TRAINING

The aerial platform is a personnel handling device; so it is necessary that it be operated and maintained only by trained personnel.

Persons under the influence of drugs or alcohol or who are subject to seizures, dizziness or loss of physical control must not operate this machine.

Operator Training

Operator training must cover:

1. Use and limitations of the controls in the platform and at the ground, emergency controls and safety systems.
2. Control labels, instructions, and warnings on the machine.
3. Rules of the employer and government regulations.
4. Use of approved fall protection device.
5. Enough knowledge of the mechanical operation of the machine to recognize a malfunction or potential malfunction.
6. The safest means to operate the machine where overhead obstructions, other moving equipment, and obstacles, depressions, holes, drop-offs.
7. Means to avoid the hazards of unprotected electrical conductors.
8. Specific job requirements or machine application.

Training Supervision

Training must be done under the supervision of a qualified person in an open area free of obstructions until the trainee has developed the ability to safely control and operate the machine.

Operator Responsibility

The operator must be instructed that he/she has the responsibility and authority to shut down the machine in case of a malfunction or other unsafe condition of either the machine or the job site.

2.2 PREPARATION, INSPECTION, AND MAINTENANCE

The following table covers the periodic machine inspections and maintenance recommended by JLG Industries, Inc. Consult local regulations for further requirements for aerial work platforms. The frequency of inspections and maintenance must be increased as necessary when the machine is used in a harsh or hostile environment, if the machine is used with increased frequency, or if the machine is used in a severe manner.

NOTICE

JLG INDUSTRIES, INC. RECOGNIZES A FACTORY-QUALIFIED SERVICE TECHNICIAN AS A PERSON WHO HAS SUCCESSFULLY COMPLETED THE JLG SERVICE TRAINING SCHOOL FOR THE SPECIFIC JLG PRODUCT MODEL.

SECTION 2 - USER RESPONSIBILITIES, MACHINE PREPARATION, AND INSPECTION

Table 2-1. Inspection and Maintenance Table

Type	Frequency	Primary Responsibility	Service Qualification	Reference
Pre-Start Inspection	Before using each day; or whenever there's an Operator change.	User or Operator	User or Operator	Operator and Safety Manual
Pre-Delivery Inspection (See Note)	Before each sale, lease, or rental delivery.	Owner, Dealer, or User	Qualified JLG Mechanic	Service and Maintenance Manual and applicable JLG inspection form
Frequent Inspection	In service for 3 months or 150 hours, whichever comes first; or Out of service for a period of more than 3 months; or Purchased used.	Owner, Dealer, or User	Qualified JLG Mechanic	Service and Maintenance Manual and applicable JLG inspection form
Annual Machine Inspection	Annually, no later than 13 months from the date of prior inspection.	Owner, Dealer, or User	Factory-Qualified Service Technician	Service and Maintenance Manual and applicable JLG inspection form
Preventative Maintenance	At intervals as specified in the Service and Maintenance Manual.	Owner, Dealer, or User	Qualified JLG Mechanic	Service and Maintenance Manual
NOTE: Inspection forms are available from JLG. Use the Service and Maintenance Manual to perform inspections.				

SECTION 2 - USER RESPONSIBILITIES, MACHINE PREPARATION, AND INSPECTION

Pre-Start Inspection

The Pre-Start Inspection should include each of the following:

1. **Cleanliness** – Check all surfaces for leakage (oil, fuel, or battery fluid) or foreign objects. Report any leakage to the proper maintenance personnel.
2. **Structure** - Inspect the machine structure for dents, damage, weld or parent metal cracks or other discrepancies.

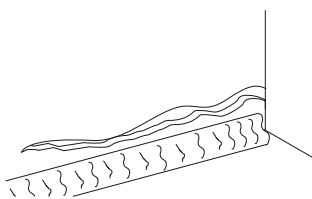

Parent Metal Crack

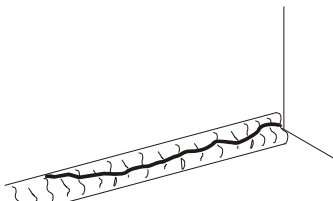

Weld Crack

3. **Decals and Placards** – Check all for cleanliness and legibility. Make sure none of the decals and placards are missing. Make sure all illegible decals and placards are cleaned or replaced.
4. **Operators and Safety Manuals** – Make sure a copy of the Operator and Safety Manual, EMI Safety Manual (Domestic only), and ANSI Manual of Responsibilities

(Domestic only) is enclosed in the weather resistant storage container.

5. **“Walk-Around” Inspection** – Refer to Figure 2-3.
6. **Battery** – Charge as required.
7. **Fuel** (Combustion Engine Powered Machines) – Add the proper fuel as necessary.
8. **Hydraulic Oil** – Check the hydraulic oil level. Ensure hydraulic oil is added as required.
9. **Function Check** – Once the “Walk-Around” Inspection is complete, perform a functional check of all systems in an area free of overhead and ground level obstructions. Refer to Section 4 for more specific instructions.

⚠ WARNING

IF THE MACHINE DOES NOT OPERATE PROPERLY, TURN OFF THE MACHINE IMMEDIATELY! REPORT THE PROBLEM TO THE PROPER MAINTENANCE PERSONNEL. DO NOT OPERATE THE MACHINE UNTIL IT IS DECLARED SAFE FOR OPERATION.

Function Check

Perform the Function Check as follows:

1. From the ground control panel with no load in the platform:
 - a. Check that all guards protecting the switches or locks are in place;
 - b. Operate all functions and check all limiting and cut-out switches;
 - c. Check auxiliary power (or manual descent);
 - d. Ensure that all machine functions are disabled when the Emergency Stop Button is activated.
2. From the platform control console:
 - a. Ensure that the control console is firmly secured in the proper location;
 - b. Check that all guards protecting the switches or locks are in place;
 - c. Operate all functions and check all limiting and cut-out switches;
 - d. Ensure that all machine functions are disabled when the Emergency Stop Button is pushed in.
3. With the platform in the transport (stowed) position:

- a. Drive the machine on a grade, not to exceed the rated gradeability, and stop to ensure the brakes hold;
- b. Check the tilt sensor alarm to ensure proper operation.

2.3 LIMIT SWITCH FUNCTIONAL CHECK



TO AVOID MACHINE UPSET DO NOT USE MACHINE IF TOWER BOOM SWITCHING IS OUT OF SEQUENCE.

IF THE TOWER BOOM LIFTS 'DOWN' WITH THE TOWER BOOM TELESCOPED 'OUT', SHUT DOWN MACHINE AND CONTACT A CERTIFIED JLG TECHNICIAN.

IF THE TOWER BOOM 'TELESCOPES' WITH THE TOWER BOOM LESS THAN FULLY ELEVATED 'UP', SHUT DOWN MACHINE AND CONTACT QUALIFIED JLG TECHNICIAN.

TO AVOID UPSET IF TOWER BOOM SWITCHING MALFUNCTIONS:

— LOWER THE PLATFORM TO GROUND VIA MAIN BOOM LIFT AND TELESCOPE FUNCTIONS.

— HAVE CONDITION CORRECTED BY A CERTIFIED JLG SERVICE TECHNICIAN BEFORE CONTINUING USE OF MACHINE.

SECTION 2 - USER RESPONSIBILITIES, MACHINE PREPARATION, AND INSPECTION

WARNING

TO AVOID COLLISION AND INJURY IF PLATFORM DOES NOT STOP WHEN A CONTROL SWITCH OR LEVER IS RELEASED, REMOVE FOOT FROM FOOTSWITCH OR USE EMERGENCY STOP TO STOP THE MACHINE.

1. Check hydraulic boom sequence cam valves. Raise, extend, retract and lower tower boom. Check for smooth and proper operation.

NOTE: *Perform checks from ground controls first, then from platform controls.*

2. Operate machine from ground control.
3. Move TOWER TELESCOPE to 'out' position. Tower should not telescope with TOWER BOOM less than fully elevated 'up'. (Must be approximately 13 degrees from vertical to move TOWER TELESCOPE 'out'.)
4. Move TOWER BOOM to 'up' position and hold until the TOWER BOOM is completely elevated. Move TOWER TELESCOPE to 'out' position and hold until the TOWER BOOM is fully extended.
5. With TOWER BOOM completely extended, place TOWER LIFT in 'down' position. Tower boom should not LIFT 'down' unless the TOWER BOOM is fully retracted.

6. Place TOWER TELESCOPE to 'in' position and fully retract the TOWER BOOM. Place TOWER BOOM to 'down' and fully lower the TOWER BOOM. Upright in vertical position. If Tower Boom does not rest on stop with machine in the stowed position, this indicates upright is out of plumb. See Section 4, Boom Synchronizing Procedure, in Service Manual.

WARNING

TO AVOID TIPPING OVER DO NOT USE MACHINE IF TOWER BOOM SWITCHING IS OUT OF SEQUENCE.

NOTE: *For adjustments see Service Manual - Limit Switch Adjustments.*

7. Check elevation limit switch as follows:

Main Boom Angle Limit Switch.

- a. Lift boom up to 5 degrees above horizontal. Limit switch should activate at this point.
- b. Lift main boom down until limit switch resets. This should be 4 degrees to 9 degrees below horizontal.

NOTE: *Angle indicator should be placed between the main boom pivot pin and the main boom lift cylinder attach point on the base boom. On machines not equipped with ADE, the main boom angle limit switch activation may be checked*

SECTION 2 - USER RESPONSIBILITIES, MACHINE PREPARATION, AND INSPECTION

by using test light in terminal # 24 in the main terminal box. Tower angle switch must be reset before main boom angle switch can be activated.

Tower Boom Angle Limit Switch.

- a. Place machine on level surface.
- b. Using the bottom of the upright and the ground as a reference, lift the tower boom 40" to 42" (101.6 to 106.6 cm) from the stowed position. The tower boom angle limit switch should activate at this point.
- c. Lower the tower boom 25" to 30" (63.5 to 76.2 cm) from where the switch activated. This switch should reset at this point.

NOTE: On machines not equipped with ADE, the tower boom angle limit switch activation may be checked by using a test light in terminal #43 on the main terminal box.

NOTE: Step 8 is only applicable for 600A ANSI market machines.

8. Check capacity limit switch as follows:

Main Boom Length Switch.

- a. Lift main boom to approximately horizontal.

- b. Telescope boom out until 500 lb. (227 kg) light comes on (may need to use auxiliary power to position boom correctly).
- c. Mark the wear pad location on the main fly boom.
- d. Telescope the main boom to full extension.
- e. Measure from the mark on the fly boom to the wear pad. The dimension should be 125" to 127" (317.5 to 322.6 cm).

Main Boom Angle Switch.

- a. Lift main boom to approximately horizontal.
- b. Telescope boom out until 500 lb. (227 kg) light comes on (may need to use auxiliary power to position boom correctly).
- c. Lift main boom up until 1000 lb. (454 kg) light comes on. The boom angle at this point should be 55 degrees to 60 degrees.
- d. Lift main boom down until 500 lb. (227 kg) light comes on. The boom angle at this point should be 45 degrees to 50 degrees.

NOTE: If limit switch settings need to be changed, you will need to recheck that the 500 lb.(227 kg) light comes on at 45 degrees to 50 degrees when lifting down.

SECTION 2 - USER RESPONSIBILITIES, MACHINE PREPARATION, AND INSPECTION

9. Raise, extend, retract and lower main boom. Check for smooth operation.
10. Swing turntable to LEFT and RIGHT a minimum of 45 degrees. Check for smooth motion.

NOTE: *Step 11 is only applicable for machines with an external tilt sensor.*

11. With the aid of an assistant to monitor the CHASSIS OUT OF LEVEL indicator light on the platform control console, manually activate the indicator light by compressing any one of the three tilt indicator mounting springs. If the light does not illuminate, shut down machine and contact a qualified service technician before continuing operation.

NOTE: *Step 12 is applicable for machines with an internal tilt sensor.*

12. Check the chassis out of level indicator located on the platform control console by driving, with the machine in level position, up a suitable ramp of at least 5° slope. Check the out of level indicator, with the machine on the ramp. If the light does not illuminate, return the machine to a level surface, shut down the machine, and contact a qualified technician before resuming operation.

SECTION 2 - USER RESPONSIBILITIES, MACHINE PREPARATION, AND INSPECTION

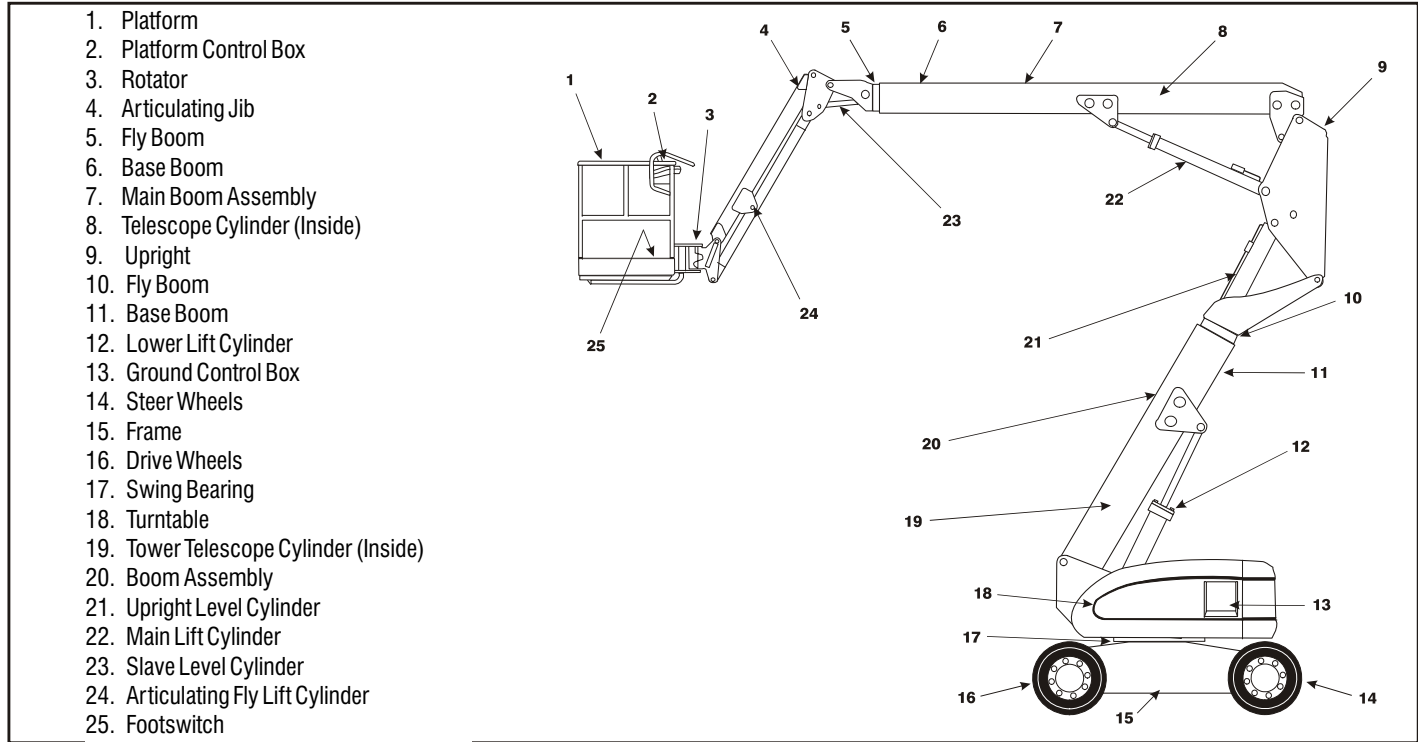

Figure 2-1. Machine Nomenclature - 600AJ

SECTION 2 - USER RESPONSIBILITIES, MACHINE PREPARATION, AND INSPECTION

1. Platform
2. Platform Control Box
3. Rotator
4. Fly Boom
5. Base Boom
6. Main Boom Assembly
7. Telescope Cylinder (Inside)
8. Upright
9. Fly Boom
10. Base Boom
11. Lower Lift Cylinder
12. Ground Control Box
13. Steer Wheels
14. Frame
15. Drive Wheels
16. Swing Bearing
17. Turntable
18. Tower Telescope Cylinder Inside)
19. Boom Assembly
20. Upright Level Cylinder
21. Main Lift Cylinder
22. Slave Level Cylinder
23. Footswitch

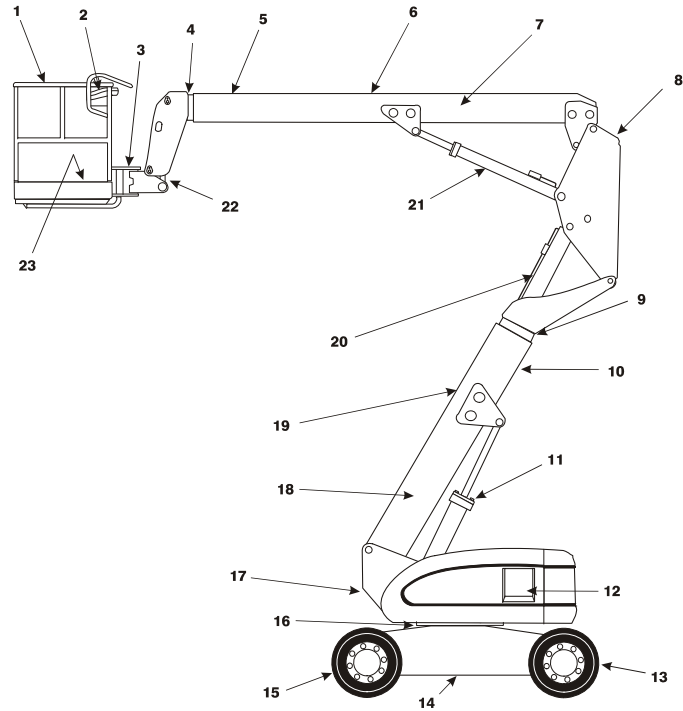

Figure 2-2. Machine Nomenclature - 600A

SECTION 2 - USER RESPONSIBILITIES, MACHINE PREPARATION, AND INSPECTION

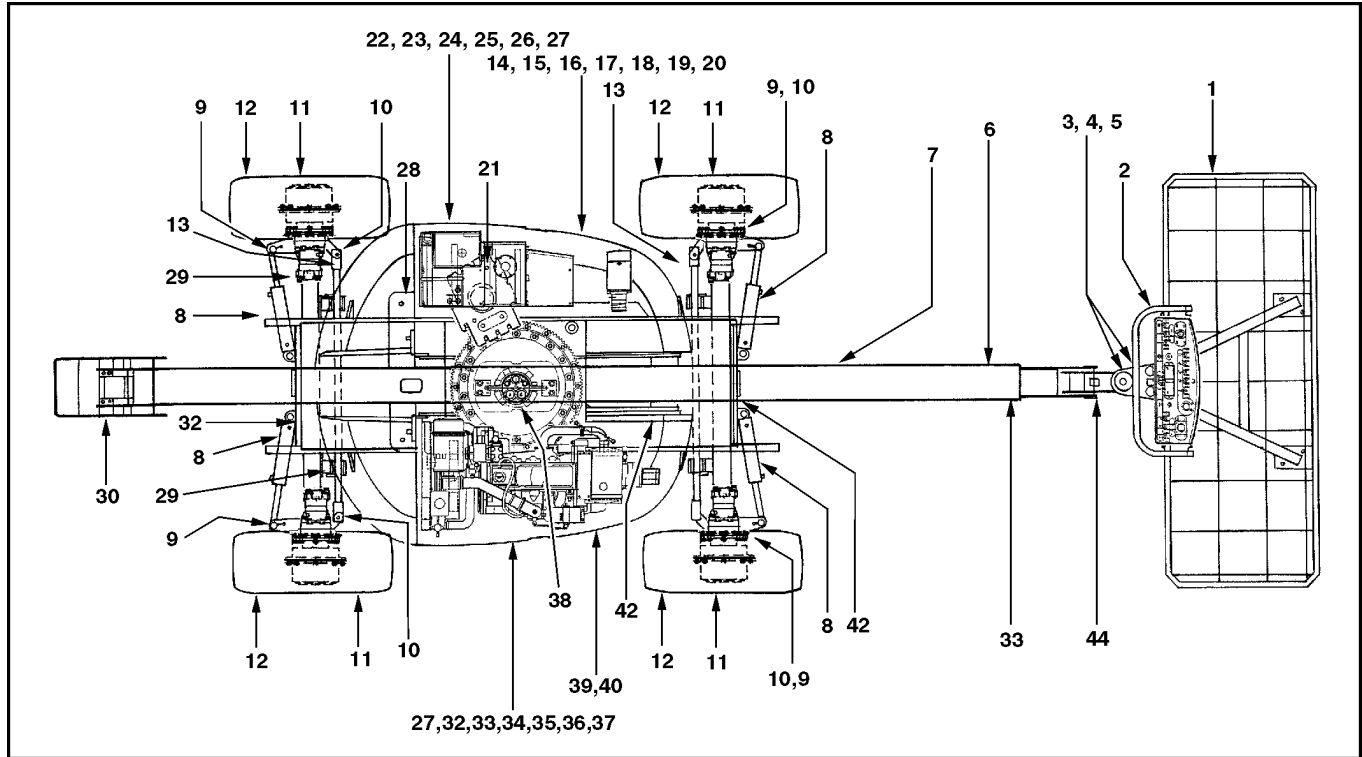

Figure 2-3. Daily Walk-Around Inspection Diagram

SECTION 2 - USER RESPONSIBILITIES, MACHINE PREPARATION, AND INSPECTION

General

Begin the “Walk-Around Inspection” at Item 1, as noted on the diagram. Continue to the right (counterclockwise viewed from top) checking each item in sequence for the conditions listed in the “Walk-Around Inspection Checklist”.

⚠ WARNING

TO AVOID POSSIBLE INJURY BE SURE MACHINE POWER IS OFF DURING "WALK-AROUND INSPECTION".

NOTICE

DO NOT OVERLOOK VISUAL INSPECTION OF CHASSIS UNDERSIDE. CHECKING THIS AREA MAY RESULT IN DISCOVERY OF CONDITIONS WHICH COULD CAUSE EXTENSIVE MACHINE DAMAGE.

NOTE: *On each item, make sure there are no loose or missing parts, that they are securely fastened and that no visible damage exists in addition to any other criteria mentioned.*

1. Platform Assembly - Platform Assembly and Gate - Footswitch works properly, not modified, disabled or blocked. Latch, stop, and hinges in working condition.
2. Platform Control Console - Switches and levers return to neutral and are properly secured, decals/placards secure and legible, control marking legible.
3. Rotator - See Note.
4. Rotator Motion Control Valve - See Note.
5. Articulating Jib Boom - See Note.
6. Dual Capacity Limit Switch - Arm free to move, and free from dirt and grease.
7. Power Track - See Note.
8. Steer Cylinder Assembly - See Note.
9. Spindle - Evidence of proper lubrication. See Note.
10. Drive Motor and Brake - See Note.
11. Drive Hub - See Note.

Figure 2-4. Daily Walk-Around Inspection Points - Sheet 1 of 3

SECTION 2 - USER RESPONSIBILITIES, MACHINE PREPARATION, AND INSPECTION

12. Wheel/Tire Assembly - No loose or missing lug nuts. Inspect for worn tread, cuts, tears or other discrepancies. Inspect wheels for damage and corrosion.
13. Tie Rod and Steering Linkage (4 Wheel Steer) - Tie rod end studs locked.
14. Turntable Lock - Operable.
15. Auxiliary Power Pump - See Note.
16. Control Valve (Tank Compartment) - See Note.
17. Turntable Bearing and Pinion - No evidence of loose bolts or looseness between bearing and structure.
18. Hydraulic Oil Medium Pressure Filter Housing - Housing secure.
19. Hydraulic Oil Return Filter Housing - Housing secure.
20. Manual Descent - See Note.
21. LP Gas Tank (If Equipped) - See Note.
22. Hydraulic Oil Supply - Recommended oil level sight gauge. (Check level with cold oil, systems shut down, machine in stowed position) Cap in place and secure.
23. Hydraulic Oil Breather - Element in place, not clogged, no sign of overflow.
24. Ground Controls - Switches operable, decals secure and legible.
25. Fuel Supply - Fuel filler cap secure. Tank - See Note.
26. Swing Drive Motor and Brake - See Note.
27. Door and Latches - Hood door and latches in working condition.
28. Oscillating Cam Valve (If Equipped) - See Note.

Figure 2-5. Daily Walk-Around Inspection Points - Sheet 2 of 3

SECTION 2 - USER RESPONSIBILITIES, MACHINE PREPARATION, AND INSPECTION

- 29. Oscillating Axle Cylinder (If Equipped) - See Note.
- 30. Dual Capacity and Horizontal Cutout Limit Switch - No damage to the switch, arm free to move, and free from dirt and grease.
- 31. Oscillating Axle (If Equipped)- See Note.
- 32. Engine Air Filter - Element clean.
- 33. Battery - Proper electrolyte levels; cables tight, no visible damage or corrosion.
- 34. Engine Oil Supply - Full mark on dipstick; filler cap secure.
- 35. Muffler and Exhaust System - See Note.
- 36. Hydraulic Pump - See Note.
- 37. Engine Tray Pivot - See Note.
- 38. Hydraulic Swivel - See Note.
- 39. LP Gas Tank (If Equipped) - See Note.
- 40. Flow Valves - See Note.
- 41. Tower Boom/Upright - Wear pads secure. All cylinders - rod end shafts and barrel-end shafts properly secured. Upright in vertical position. If Tower Boom does not rest on stop with machine in the stowed position, this indicates upright is out of plumb.
- 42. Frame - See Note.
- 43. Main Boom Sections - Wear pads secure. All cylinders - rod end shafts and barrel-end shafts properly secured.
- 44. Platform Pivot Pin - See Note.

Figure 2-6. Daily Walk-Around Inspection Points - Sheet 3 of 3

SECTION 3. MACHINE CONTROLS AND INDICATORS

3.1 GENERAL

NOTICE

THE MANUFACTURER HAS NO DIRECT CONTROL OVER MACHINE APPLICATION AND OPERATION. THE USER AND OPERATOR ARE RESPONSIBLE FOR CONFORMING WITH GOOD SAFETY PRACTICES.

This section provides the necessary information needed to understand control functions.

3.2 CONTROLS AND INDICATORS

NOTE: All machines are equipped with control panels that use symbols to indicate control functions. On ANSI machines refer to decal located on the control box guard in front of the control box or by the ground controls for these symbols and the corresponding functions.

NOTE: The indicator panels use different shaped symbols to alert the operator to different types of operational situations that could arise. The meaning of those symbols are explained below.



Indicates a potentially hazardous situation, which if not corrected, could result in serious injury or death. This indicator will be red.



Indicates an abnormal operating condition, which if not corrected, may result in machine interruption or damage. This indicator will be yellow.



Indicates important information regarding the operating condition, i.e. procedures essential for safe operation. This indicator will be green with the exception of the capacity indicator which will be green or yellow depending upon platform position.

SECTION 3 - MACHINE CONTROLS AND INDICATORS

Ground Controls

(See Figure 3-1., Ground Control Station)

NOTE: If equipped, the Function Enable switch must be held down in order to operate Main Boom Telescope, Tower Lift, Swing, Main Lift, Jib Lift, Platform Level Override, and Platform Rotate functions.



1. Platform Rotate

A three position switch permits rotation of the platform.

⚠ WARNING

ONLY USE THE PLATFORM LEVELING OVERRIDE FUNCTION FOR SLIGHT LEVELING OF THE PLATFORM. INCORRECT USE COULD CAUSE THE LOAD/OCCUPANT TO SHIFT OR FALL. FAILURE TO DO SO COULD RESULT IN DEATH OR SERIOUS INJURY.

2. Platform Leveling Override

A three position switch allows the operator to compensate for any difference in the automatic self leveling system.

3. Jib (If Equipped)

This switch provides raising and lowering of the jib.

NOTE: When Power/Emergency Stop switch is in the “ON” position and engine is not running, an alarm will sound, indicating Ignition is “ON”.

⚠ CAUTION

WHEN THE MACHINE IS SHUT DOWN THE MASTER/EMERGENCY STOP SWITCH MUST BE POSITIONED TO THE “OFF” POSITION TO PREVENT DRAINING THE BATTERY.

NOTE: On machines with diesel engines, when Glow Plug Indicator is lighted (Yellow), wait until light goes out before cranking engine.

4. Power/Emergency Stop Switch

Pull out ON-OFF POWER/EMERGENCY STOP SWITCH to turn on engine ignition and power to the electrical system. Push in to shut off engine and remove power from the controls. The Ground Control Emergency Stop Switch must be pulled out to operate the machine from either Ground Control or Platform Control. This allows the machine to be shut down in emergency situations by those untrained in the operation of the lift but who recognize the Emergency Stop Switch. The keyed Master Switch can also be used for the same purpose.

SECTION 3 - MACHINE CONTROLS AND INDICATORS

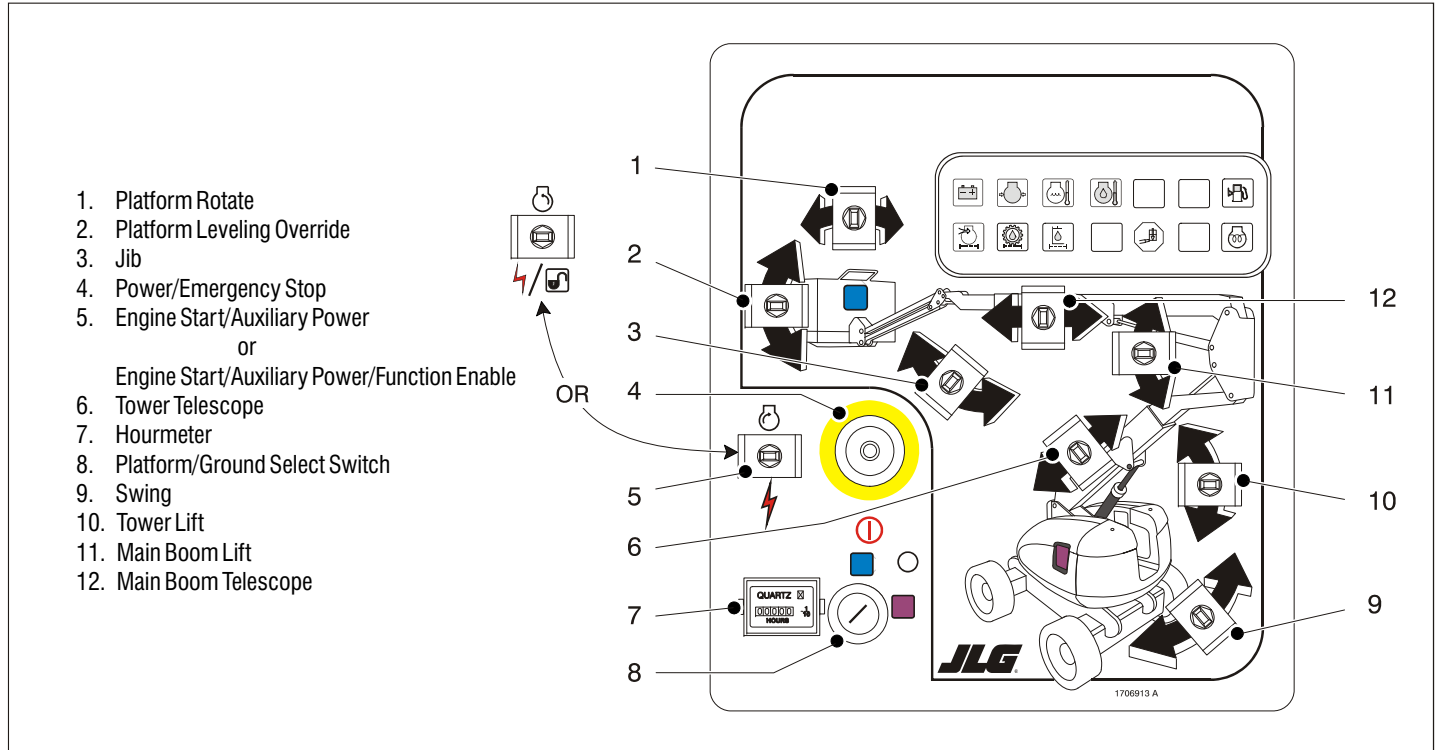

Figure 3-1. Ground Control Station

SECTION 3 - MACHINE CONTROLS AND INDICATORS

5. Engine Start/Auxiliary Power Switch

or

Engine Start/ Auxiliary Power Switch /Function Enable.



To start the engine, the switch must be held "UP" until the engine starts.



To use auxiliary power, the switch must be held "DOWN" for duration of auxiliary pump use. Aux power can only be used if the engine is not running.



If equipped, the enable switch must be held "DOWN" to enable all boom controls when the engine is running.

6. Tower Telescope

This switch provides raising and lowering of the tower boom. This function works only when the tower boom is fully elevated (lift up).

⚠ WARNING

TO AVOID UPSET AND SERIOUS INJURY, DO NOT OPERATE MACHINE IF TOWER LIFT AND TELESCOPE FUNCTIONS DO NOT OPERATE IN THE ABOVE SEQUENCE.

7. Hourmeter

Registers the amount of time the machine has been in use, with engine running. By connecting into the oil pressure circuit of the engine, only engine run hours are recorded. The hourmeter registers up to 9,999.9 hours and cannot be reset.

8. Platform/Ground Select Switch

A three position, center off, key activated PLATFORM/GROUND SELECT switch supplies power to the platform control console when positioned to PLATFORM. With the switch in GROUND position, power is shut off to the platform control console, and only the controls on the ground control panel are operable.

NOTE: *With the Platform/Ground Select Switch in the center position, power is shut off to controls at both operating stations.*

9. Swing Control

Provides 360 degrees continuous turntable rotation.

NOTE: *Main Lift, Tower Lift, Swing, Platform Level, Main Telescope, Tower Telescope, Platform Rotator and Auxiliary Power control switches are spring-loaded and will automatically return to neutral (off) when released.*

WARNING

WHEN OPERATING THE BOOM ENSURE THERE ARE NO PERSONNEL AROUND OR UNDER PLATFORM.

WARNING

TO AVOID SERIOUS INJURY, DO NOT OPERATE MACHINE IF ANY CONTROL LEVERS OR TOGGLE SWITCHES CONTROLLING PLATFORM MOVEMENT DO NOT RETURN TO THE OFF POSITION WHEN RELEASED.

10. Tower Lift

This switch provides raising and lowering of the tower boom. This function works only when the tower boom is fully retracted (telescope in).

11. Main Lift Control

Provides raising and lowering of the main boom.

12. Main Telescope Control

Provides extension and retraction of the boom, when positioned to IN or OUT.

SECTION 3 - MACHINE CONTROLS AND INDICATORS

Ground Control Indicator Panel

(See Figure 3-2., Ground Control Indicator Panel)

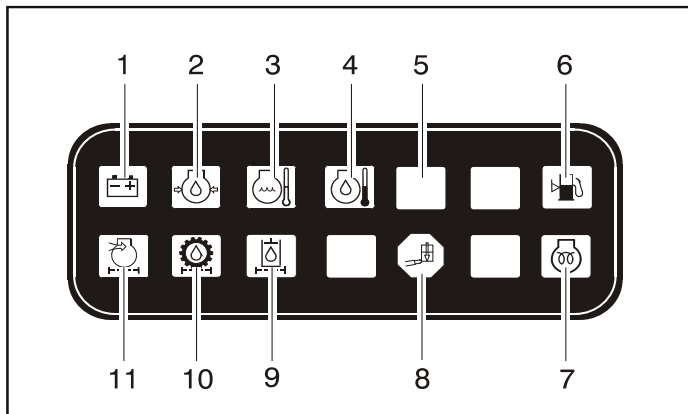

- | | |
|---------------------------------|---------------------------------|
| 1. Battery Charging | 7. Glow Plug |
| 2. Engine Oil Pressure | 8. Platform Overload |
| 3. Engine Water Temp. | 9. Hyd. Filter Bypass |
| 4. Engine Oil Temp. | 10. Transmission Filter By-Pass |
| 5. Engine Malfunction Indicator | 11. Engine Air Filter By-Pass |
| 6. Low Fuel | |

Figure 3-2. Ground Control Indicator Panel

1. Battery Charging Indicator

Indicates a problem in the battery or charging circuit, and service is required.

2. Engine Oil Pressure Indicator

Indicates that engine oil pressure is below normal and service is required.

3. Engine Coolant Temperature (Ford and Continental) Indicator

Indicates that engine coolant temperature is abnormally high and service is required.

4. Engine Oil Temperature Indicator (Deutz)

Indicates the temperature of the engine oil, which also serves as engine coolant, is abnormally high and service is required.

SECTION 3 - MACHINE CONTROLS AND INDICATORS

5. Engine Malfunction Indicator (Ford Engines S/N 48907 to S/N 64249 - refer to ADE System Identification page at the front of the book).

Indicates that the Engine Control Module has detected a malfunction in the Electronic Fuel Injection System and a Diagnostic Trouble Code has been set in the ECM. Refer to the Service Manual for instructions concerning the trouble codes and trouble code retrieval.

The malfunction indicator light will illuminate for 2-3 seconds when the key is positioned to the on position to act as a self test.

6. Low Fuel Level Indicator

Indicates that the fuel level is 1/8 full or less. When the light first turns on, there are approximately four usable gallons of fuel remaining.

7. Glow Plug Indicator (Diesel)

Indicates glow plugs are on. The glow plugs are automatically turned on with the ignition circuit and remain on for approximately about seven seconds. Start the engine only after the light goes out.

8. Platform Overload (If equipped)

Indicates the platform has been overloaded.

9. Hydraulic Oil Filter Indicator (Prior to S/N 84829)

Indicates the return oil filter is too restrictive and needs to be replaced.

10. Transmission Pump Oil Filter Indicator (Prior to S/N 84829)

Indicates that charge pump filter is too restrictive and needs to be replaced. This indicator has an integral temperature sensor (70 degrees F.) so that false signals are not generated when the hydraulic oil is below normal operating temperature.

11. Engine Air Filter Indicator (Prior to S/N 84829)

Indicates that the air filter is too restrictive and needs to be replaced.

SECTION 3 - MACHINE CONTROLS AND INDICATORS

12. EFI System Test Button (Ford Engines S/N 48907 to S/N 64249 - refer to ADE System Identification page at the front of the book).

By pushing and holding the system test button on the side of the ground control box, the Diagnostic Trouble Codes will be displayed on the Malfunction Indicator Light

Light. Refer to the Service Manual for instructions concerning the trouble codes and trouble code retrieval.

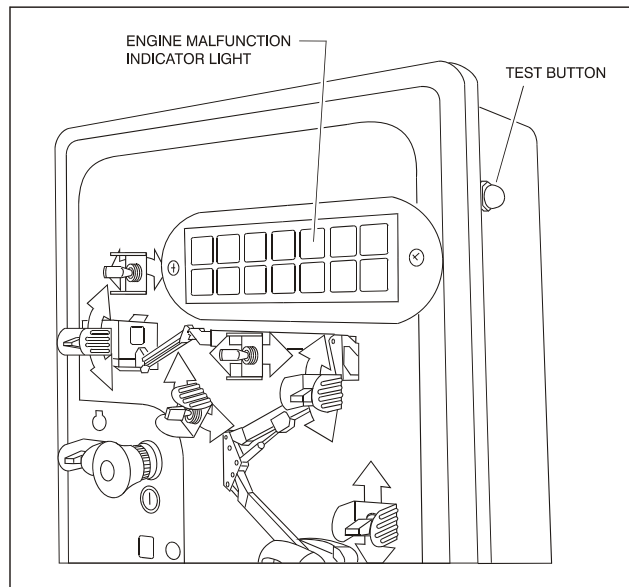

Figure 3-3. Malfunction Indicator Light and Test Button

Platform Control

(See Figure 3-4. and Figure 3-5.)

1. Drive Speed/Torque Select

The machine has a two position switch — The forward position produces maximum speed and torque by giving speed when the drive controller is moved. The backward position allows the machine to be driven with the engine at mid speed.

2. Steer Select (If Equipped)

When equipped with four wheel steering, the action of the steering system is operator selectable. The center switch position gives conventional front wheel steering with the rear wheels unaffected. This is for normal driving at maximum speeds. The forward position is for “crab” steering. When in this mode both front and rear axles steer in the same direction, which allows the chassis to move sideways as it goes forward. This can be used for positioning the machine in aisle ways or against buildings. The back switch position is for “coordinated” steering. In this mode the front and rear axles steer in the opposite directions to produce the tightest turning circle for maneuvering in confined areas.

To re-synchronize the front and rear axles, position the

rear drive wheels to the forward drive position by selecting either crab or compound steer, then select front steer (center switch position) to operate the normal steering function.

WARNING

ONLY USE THE PLATFORM LEVELING OVERRIDE FUNCTION FOR SLIGHT LEVELING OF THE PLATFORM. INCORRECT USE COULD CAUSE THE LOAD/OCCUPANT TO SHIFT OR FALL. FAILURE TO DO SO COULD RESULT IN DEATH OR SERIOUS INJURY.

3. Platform Leveling Override

This switch allows the operator to adjust the level of the platform.

4. Horn

Supplies electrical power to the horn when pressed.

5. Power/Emergency Stop

An ON-OFF POWER/EMERGENCY STOP switch and a separate ENGINE START/AUXILIARY POWER toggle switch on the platform console supply electrical power to the starter solenoid, when the ignition switch is placed in the “ON” position and the ENGINE START switch is push forward.

SECTION 3 - MACHINE CONTROLS AND INDICATORS

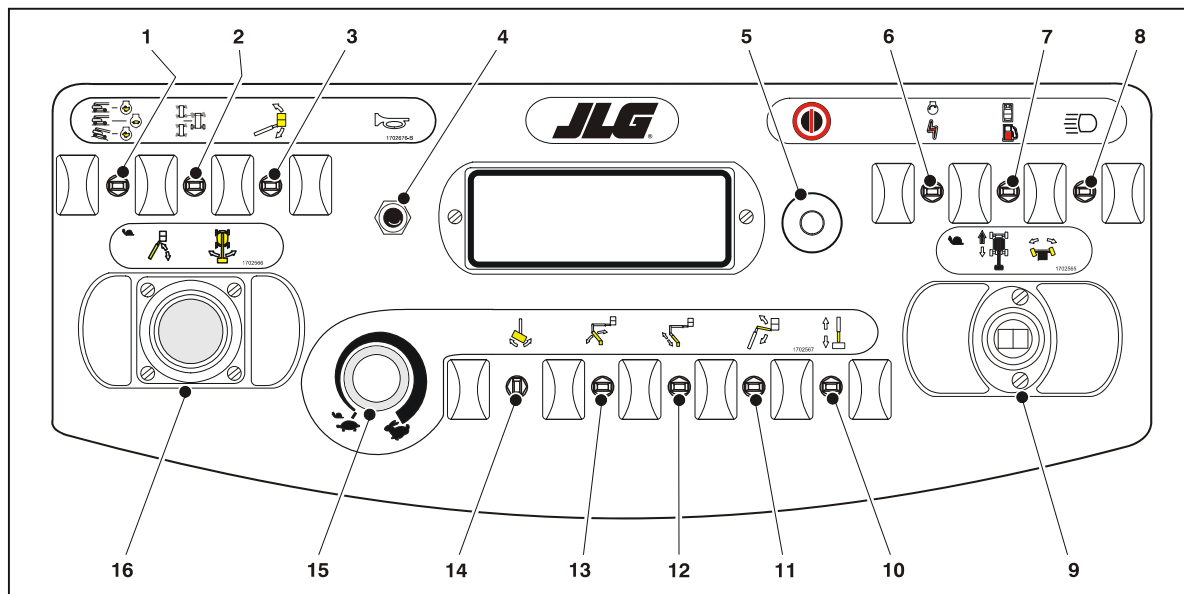

- | | | | |
|-------------------------------|-------------------------|---------------------|---------------------|
| 1. Drive Speed | 5. Power/Emergency Stop | 9. Drive/Steer | 13. Tower Lift |
| 2. Steer Select | 6. Aux. Power | 10. Telescope | 14. Platform Rotate |
| 3. Platform Leveling Override | 7. Fuel Select | 11. Jib | 15. Function Speed |
| 4. Horn | 8. Lights | 12. Tower Telescope | 16. Main Lift/Swing |

Figure 3-4. Platform Control Console

SECTION 3 - MACHINE CONTROLS AND INDICATORS

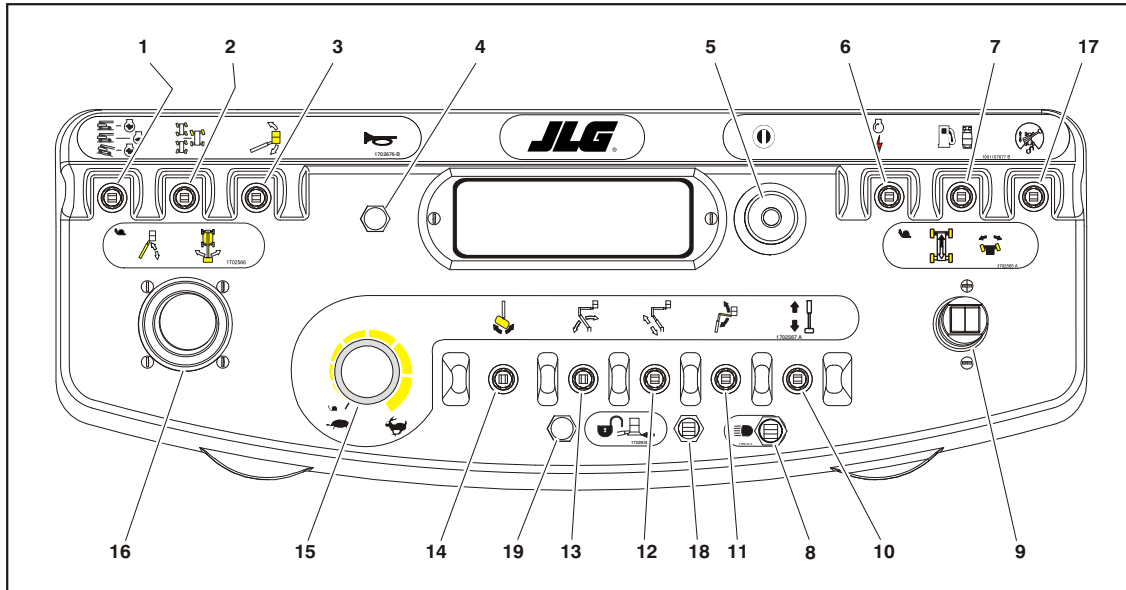

- | | | | | |
|-------------------------------|-------------------------|---------------------|---------------------|--------------------------------|
| 1. Drive Speed | 5. Power/Emergency Stop | 9. Drive/Steer | 13. Tower Lift | 17. Drive Orientation Override |
| 2. Steer Select | 6. Aux. Power | 10. Telescope | 14. Platform Rotate | 18. Soft Touch Override |
| 3. Platform Leveling Override | 7. Fuel Select | 11. Jib | 15. Function Speed | 19. Soft Touch Indicator |
| 4. Horn | 8. Lights | 12. Tower Telescope | 16. Main Lift/Swing | |

Figure 3-5. Platform Control Console - w/Drive Orientation

SECTION 3 - MACHINE CONTROLS AND INDICATORS

6. Auxiliary Power

Energizes the electrically operated hydraulic pump, when actuated. (Switch must be held ON for duration of auxiliary pump use.)

The auxiliary pump functions to provide sufficient oil flow to operate the basic machine functions should the main pump or engine fail. The auxiliary pump will operate tower boom lift, tower telescope, main boom lift, main telescope and swing.

7. Fuel Select (Dual Fuel Engine Only) (If Equipped)

Gasoline or liquid propane fuel may be selected by moving the switch to the appropriate position. It is unnecessary to purge the fuel system before switching fuels, so there is no waiting period when switching fuels while the engine is running.

8. Lights (If Equipped)

This switch operates control console panel lights and head lights if the machine is so equipped. The ignition switch does not have to be on to operate the lights, so care must be taken to avoid draining the battery if left unattended. The master switch and / or the ignition switch at the ground control will turn off power to all lights.

9. Drive/Steer

The DRIVE joystick provides for driving either forward or backward. The controller is 'ramped' to allow variable drive speed.

Steering is controlled by a thumb operated switch on top of the joystick.

NOTE: *When boom is positioned above horizontal and any of the following switches, DRIVE SPEED/TORQUE SELECT or FUNCTION SPEED, are positioned to HIGH, high function speeds are automatically cut out and the machine continues to operate at a lower speed.*

SECTION 3 - MACHINE CONTROLS AND INDICATORS

10. Main Telescope Control

This control allows extension and retraction of the main boom.

11. Jib (If Equipped)

Push forward to lift up, pull back to lift down. Variable lift speed is using the Function Speed Control.

12. Tower Telescope

This three position switch provides for extending and retracting of the tower boom. TOWER TELESCOPE must be fully RETRACTED before operating TOWER LIFT. (TOWER TELESCOPE should not function when TOWER LIFT is not fully elevated "UP").

13. Tower Lift

This three position switch provides for raising and lowering of the tower boom. TOWER LIFT must be fully elevated "UP" before operating TOWER TELESCOPE. (TOWER LIFT should not function when TOWER TELESCOPE is extended).

NOTE: *MAIN LIFT, SWING, and DRIVE control levers are spring-loaded and will automatically return to neutral (OFF) position when released.*

WARNING

TO AVOID SERIOUS INJURY, DO NOT OPERATE MACHINE IF ANY CONTROL LEVERS OR TOGGLE SWITCHES CONTROLLING PLATFORM MOVEMENT DO NOT RETURN TO THE OFF OR NEUTRAL POSITION WHEN RELEASED.

WARNING

TO AVOID TIPPING OVER AND SERIOUS INJURY, DO NOT OPERATE MACHINE IF TOWER LIFT AND TELESCOPE DO NOT OPERATE IN THE ORDER PRESCRIBED IN (12) AND (13) ABOVE.

SECTION 3 - MACHINE CONTROLS AND INDICATORS

14. Platform Rotate

This switch allows the operator to rotate the basket to the left or right.



DO NOT OPERATE MACHINE IF DRIVE SPEED /TORQUE SELECT OR FUNCTION SPEED SWITCHES OPERATE WHEN BOOM IS ABOVE HORIZONTAL.

15. Function Speed Control

Controls the speed of Boom and Swing Functions. Rotate CCW for slower speed and CW for faster speed. To adjust to creep, turn knob fully CCW until it clicks.

16. Main Lift/Swing Controller

An infinitely proportional dual axis joystick is provided for main lift and swing. Push forward to lift up, pull backward to lift down. Move right to swing right, move left to swing left.

17. Drive Orientation Override

When the boom is swung over the rear tires or further in either direction, the Drive Orientation indicator will illuminate when the drive function is selected. Push and release the switch, and within 3 seconds move the Drive/Steer control to activate drive or steer. Before driving, locate the black/white orientation arrows on both the chassis and the platform controls and match the control direction arrow to the intended chassis direction.

18. Soft Touch Override Switch (If equipped)

This switch enables the functions that were cut out by the Soft Touch system to operate again at creep speed, allowing the operator to move the platform away from the obstacle that caused the shutdown situation.

19. Soft Touch Indicator (If Equipped)

Indicates the Soft Touch bumper is against an object. All controls are cut out until the override button is pushed, at which time controls are active in the Creep Mode.

Platform Control Indicator Panel

(See Figure 3-6. and Figure 3-7.)

1. Tilt Alarm Warning Light and Alarm

This orange illuminator indicates that the chassis is on a slope. An alarm will also sound when the chassis is on a slope and the boom is above horizontal. If lit when boom is raised or extended, retract and lower to below horizontal then reposition machine so that it is level before continuing operation. If the boom is above horizontal and the machine is on a slope, the tilt alarm warning light will illuminate and an alarm will sound and CREEP is automatically activated.

WARNING

IF TILT WARNING LIGHT IS ILLUMINATED WHEN BOOM IS RAISED OR EXTENDED, RETRACT AND LOWER TO BELOW HORIZONTAL THEN REPOSITION MACHINE SO THAT IT IS LEVEL BEFORE EXTENDING BOOM OR RAISING BOOM ABOVE HORIZONTAL.

2. Platform Overload (If equipped)

Indicates the platform has been overloaded.

3. Capacity Indicator

Indicates the maximum platform capacity for the current position of the platform. Restricted capacities are permitted at restricted platform positions (shorter boom lengths and higher boom angles).

NOTE: Refer to the capacity decals on the machine for restricted and unrestricted platform capacities.

SECTION 3 - MACHINE CONTROLS AND INDICATORS

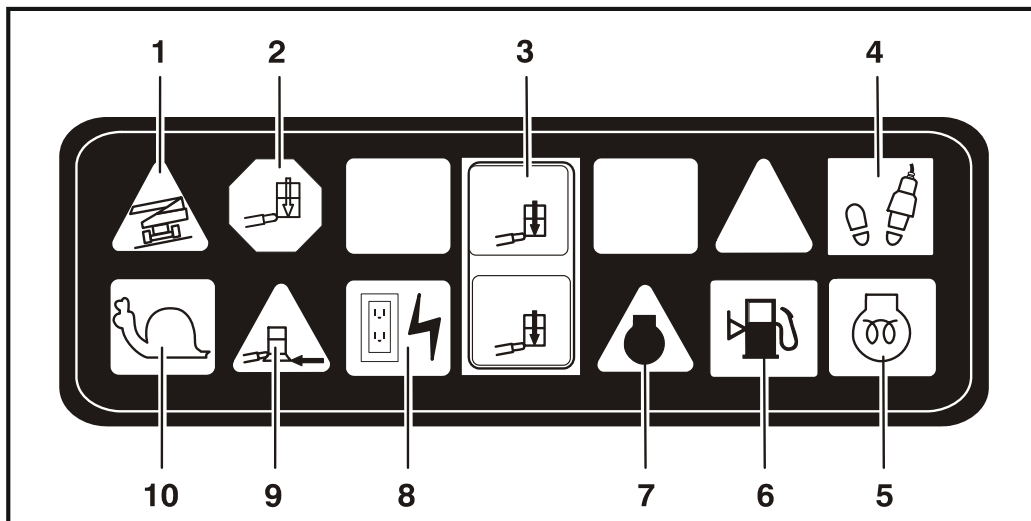

- | | | |
|-------------|-----------------------|---------------|
| 1. Tilt | 5. Glow Plug | 9. Soft Touch |
| 2. Overload | 6. Low Fuel | 10. Creep |
| 3. Capacity | 7. Engine Malfunction | |
| 4. Enable | 8. AC Generator | |

Figure 3-6. Platform Control Indicator Panel

SECTION 3 - MACHINE CONTROLS AND INDICATORS

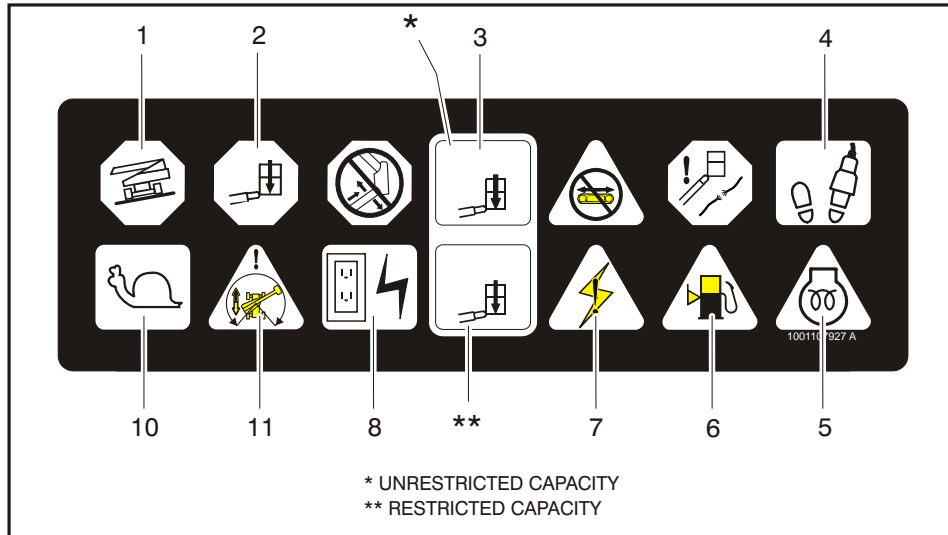

- | | | |
|-------------|-----------------------|-----------------------|
| 1. Tilt | 5. Glow Plug | 9. Not Used |
| 2. Overload | 6. Low Fuel | 10. Creep |
| 3. Capacity | 7. Engine Malfunction | 11. Drive Orientation |
| 4. Enable | 8. AC Generator | |

Figure 3-7. Platform Control Indicator Panel - w/Drive Orientation

SECTION 3 - MACHINE CONTROLS AND INDICATORS

4. Enable Indicator/Footswitch

To operate any function, the footswitch must be depressed and the function selected within seven seconds. The enable indicator shows that the controls are enabled. If a function is not selected within seven seconds, or if a seven second lapse between ending one function and beginning the next function, the enable light will go out and the footswitch must be released and depressed again to enable the controls.

Releasing the footswitch removes power from all controls and applies the drive brakes.

WARNING

TO AVOID SERIOUS INJURY, DO NOT REMOVE, MODIFY OR DISABLE THE FOOTSWITCH BY BLOCKING OR ANY OTHER MEANS.

WARNING

FOOTSWITCH MUST BE ADJUSTED IF FUNCTIONS ACTIVATE WHEN SWITCH ONLY OPERATES WITHIN LAST 1/4" (6.3 MM) OF TRAVEL, TOP OR BOTTOM.

5. Glow Plug Indicator

When illuminated the glow plugs are operating. After turning on ignition, wait until light goes out before cranking engine.

6. Low Fuel Indicator (Yellow)

Indicates the fuel tank is 1/8 full or less. When the light first turns on, there are approximately four usable gallons of fuel remaining.

7. Engine Malfunction Indicator

On all machines prior to S/N 48907 and machines with a Deutz engine prior to S/N 64249, the light turns on and an alarm sounds when machine's power system requires immediate service. Any of the following conditions will turn on light and alarm: low engine oil pressure, high engine coolant temperature, clogged engine air filter, low alternator output, clogged hydraulic oil return filter, or clogged charge pump filter.

On machines with Ford engines from S/N 48907 and machines with Deutz engines after S/N 64249, the light indicates that the Engine Control System has detected a malfunction and a Diagnostic Trouble Code has been set in the system memory. Refer to the Service Manual for instructions concerning the trouble codes and trou-

SECTION 3 - MACHINE CONTROLS AND INDICATORS

ble code retrieval.

The malfunction indicator light will illuminate for 2-3 seconds when the key is positioned to the on position to act as a self test.

8. AC Generator (Green)

Indicates the generator is in operation.

9. Soft Touch Indicator (If Equipped)

Indicates the Soft Touch bumper is against an object. All controls are cut out until the override button is pushed, at which time controls are active in the Creep mode.

10. Creep Speed Indicator

When the Function Speed Control is turned to the creep position, the indicator acts as a reminder that all functions are set to the slowest speed.

11. Drive Orientation Indicator

When the boom is swung beyond the rear drive tires or further in either direction, the Drive Orientation indicator will illuminate when the drive function is selected. This is a signal for the operator to activate the Drive Orientation Override Switch and verify the drive control direction is correct.

SECTION 4. MACHINE OPERATION

4.1 DESCRIPTION

This machine is a self-propelled hydraulic lift equipped with a work platform on the end of an elevating, articulating and rotating boom.

The primary operator control station is in the platform. From this control station, the operator can drive and steer the machine in both forward and reverse directions. The operator can raise or lower the upper or lower boom or swing the boom to the left or right. Standard boom swing is 360° continuous left and right of the stowed position. The machine has a Ground Control Station which will override the Platform Control Station. Ground Controls operate Boom Lift and Swing, and are to be used in an emergency to lower the platform to the ground should the operator in the platform be unable to do so. The Ground Control is also to be used in Pre-Start Inspection.

4.2 OPERATING CHARACTERISTICS AND LIMITATIONS

Capacities

The boom can be raised above horizontal with or without any load in platform, if:

1. Machine is positioned on a smooth, firm and level surface.
2. Load is within manufacturer's rated capacity.
3. All machine systems are functioning properly.
4. Proper tire pressure.
5. Machine is as originally equipped from JLG.

Stability

Machine stability is based on two positions which are called FORWARD and BACKWARD stability. The machines position of least BACKWARD stability is shown in Figure 4-2., Position of Least Backward Stability and its position of least FORWARD stability is shown in Figure 4-1., Position of Least Forward Stability.

WARNING

TO AVOID FORWARD OR BACKWARD TIPPING, DO NOT OVERLOAD MACHINE OR OPERATE THE MACHINE ON AN OUT-OF-LEVEL SURFACE.

4.3 ENGINE OPERATION

NOTE: *Initial starting should always be performed from the Ground Control station.*

Starting Procedure

CAUTION

IF ENGINE FAILS TO START PROMPTLY, DO NOT CRANK FOR AN EXTENDED TIME. SHOULD ENGINE FAIL TO START AGAIN, ALLOW STARTER TO “COOL OFF” FOR 2-3 MINUTES. IF ENGINE FAILS AFTER SEVERAL ATTEMPTS, REFER TO ENGINE MAINTENANCE MANUAL.

NOTE: *Diesel engines only: After turning on ignition, operator must wait until glow plug indicator light goes out before cranking engine.*

1. Turn key of SELECT switch to GROUND. Position POWER/EMERGENCY STOP switch to ON, then push the ENGINE START switch until engine starts.

CAUTION

ALLOW ENGINE TO WARM-UP FOR A FEW MINUTES AT LOW SPEED BEFORE APPLYING ANY LOAD.

2. After engine has had sufficient time to warm up, shut engine off.
3. Turn SELECT switch to PLATFORM.
4. From Platform, pull POWER/EMERGENCY STOP switch out, then push the ENGINE START switch until engine starts.

NOTE: *Footswitch must be in released (up) position before starter will operate. If starter operates with footswitch in the depressed position, DO NOT OPERATE MACHINE.*

Shutdown Procedure



IF AN ENGINE MALFUNCTION CAUSES AN UNSCHEDULED SHUTDOWN, DETERMINE THE CAUSE AND CORRECT IT BEFORE RESTARTING THE ENGINE.

1. Remove all load and allow engine to operate at low speed for 3-5 minutes; this allows further reduction of internal engine temperature.
2. Push POWER/EMERGENCY STOP switch in.
3. Turn MASTER switch to Off.

Refer to Engine Manufacturer's manual for detailed information.

SECTION 4 - MACHINE OPERATION

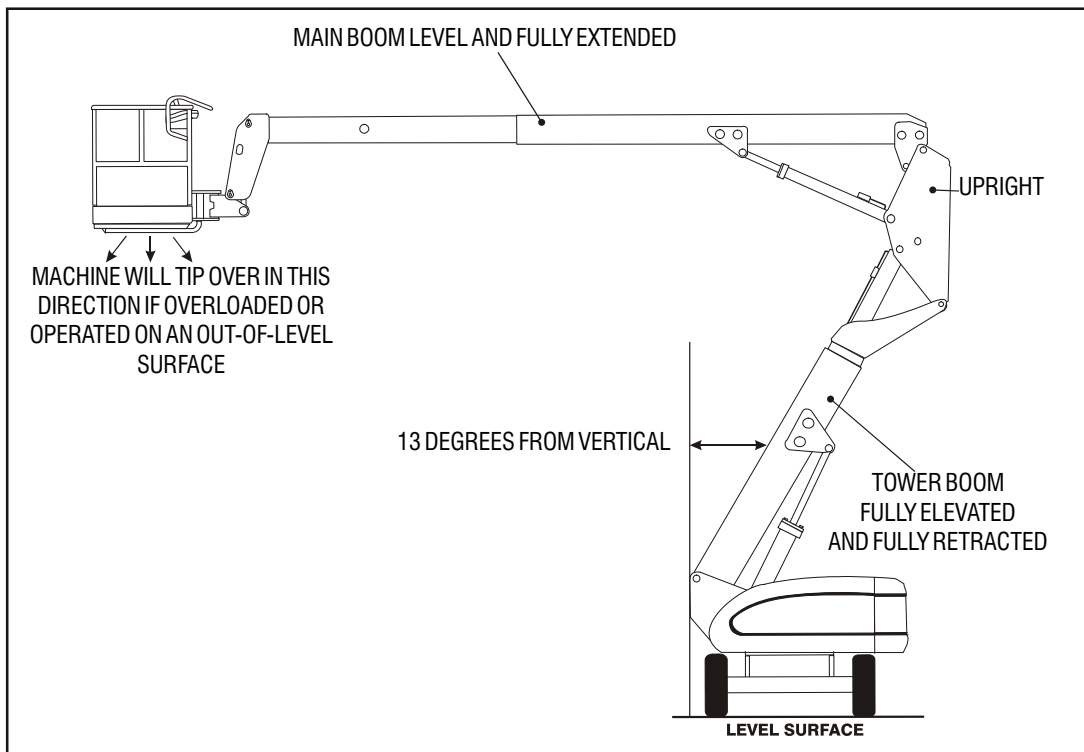

Figure 4-1. Position of Least Forward Stability

4.4 TRAVELING (DRIVING)

⚠ WARNING

DO NOT DRIVE WITH BOOM ABOVE HORIZONTAL EXCEPT ON A SMOOTH, FIRM AND LEVEL SURFACE.

TO AVOID LOSS OF TRAVEL CONTROL OR "TIP OVER", DO NOT DRIVE MACHINE ON GRADES EXCEEDING THOSE SPECIFIED ON THE SERIAL NUMBER PLATE.

BE SURE THE TURNTABLE LOCK IS ENGAGED BEFORE ANY EXTENDED TRAVELING.

DO NOT DRIVE ON SIDESLOPES WHICH EXCEED 5 DEGREES.

USE EXTREME CAUTION WHEN DRIVING IN REVERSE AND AT ALL TIMES WHEN THE PLATFORM IS ELEVATED.

BEFORE DRIVING, MAKE SURE BOOM IS POSITIONED OVER REAR DRIVE AXLE. IF BOOM IS OVER FRONT WHEELS, STEER AND DRIVE CONTROLS WILL BE REVERSED.

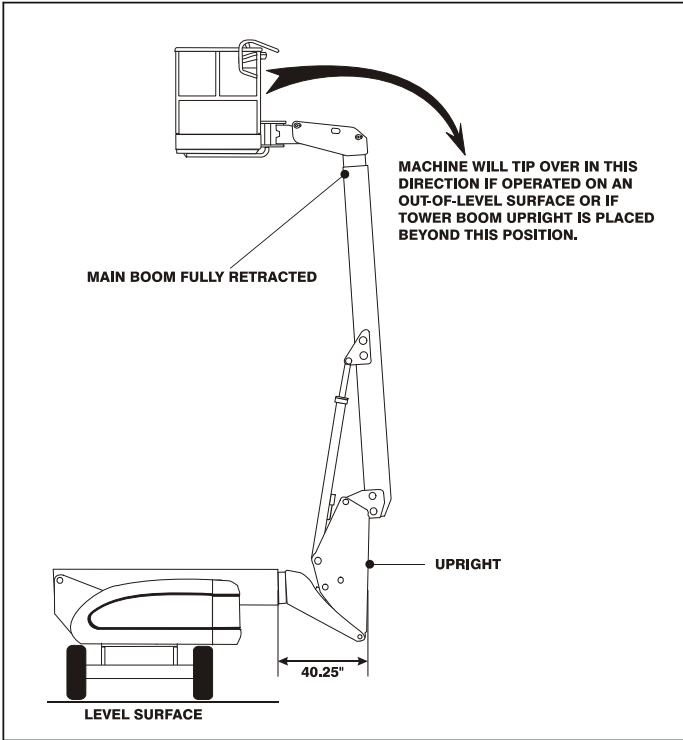

Figure 4-2. Position of Least Backward Stability

Traveling Forward and Reverse

1. At Platform Controls, pull out Emergency Stop switch and activate footswitch.
2. Position Drive controller to FORWARD or REVERSE as desired.

This machine is equipped with a Drive Orientation Indicator. The yellow light on the platform control console indicates that the boom is swung beyond the rear drive tires and the machine may Drive/Steer in the opposite direction from the movement of the controls. If the indicator is illuminated, operate the Drive function in the following manner:

1. Match the black and white direction arrows on both platform control panel and the chassis to determine the direction the machine will travel.
2. Push and release the Drive Orientation Override switch. Within 3 seconds, slowly move the Drive control toward the arrow matching the intended direction of machine travel. The indicator light will flash during the 3 second interval until the drive function is selected.

4.5 STEERING

Position thumb switch on Drive/Steer controller to RIGHT for steering right, or to LEFT for steering left.

4.6 PLATFORM

Platform Level Adjustment

To Level Up or Down - Position the Platform/Level control switch Up or Down and hold until the platform is level.

WARNING

ONLY USE THE PLATFORM LEVELING OVERRIDE FUNCTION FOR SLIGHT LEVELING OF THE PLATFORM. INCORRECT USE COULD CAUSE THE LOAD/OCCUPANT TO SHIFT OR FALL. FAILURE TO DO SO COULD RESULT IN DEATH OR SERIOUS INJURY.

Platform Rotation

To rotate the platform to the left or right, use the Platform Rotate control switch to select the direction and hold until desired position is reached.

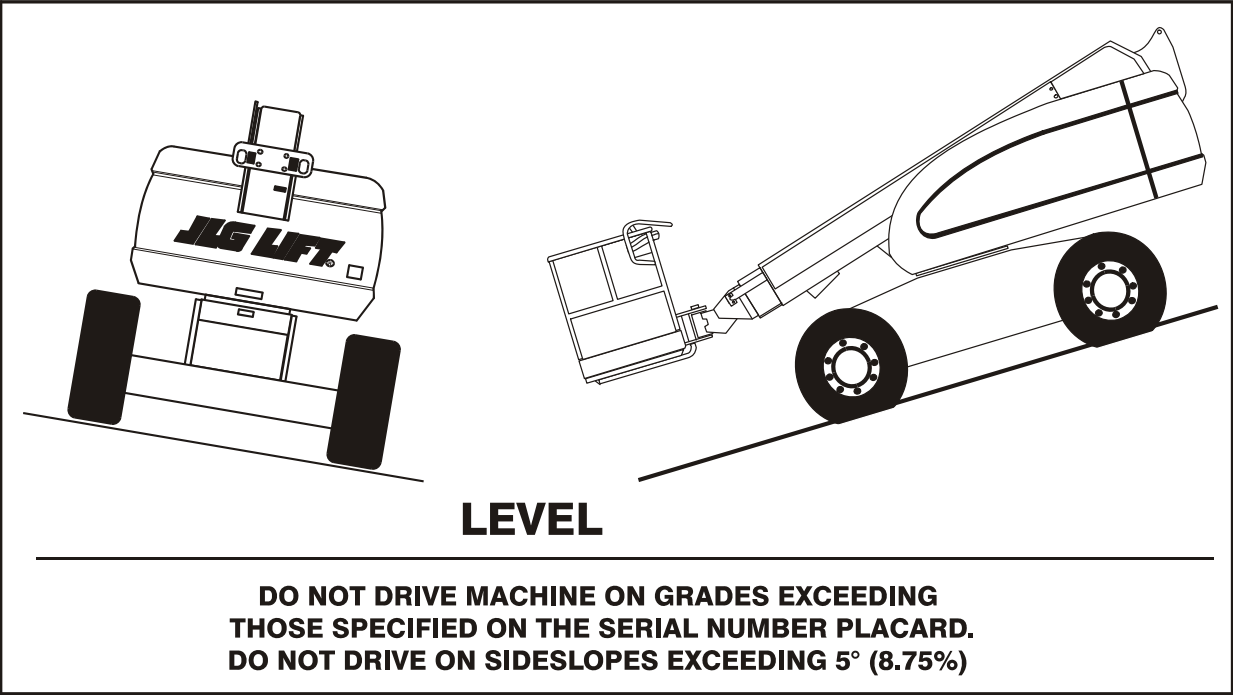

Figure 4-3. Grade and Sideslope

4.7 BOOM

WARNING

DO NOT SWING OR RAISE BOOM ABOVE HORIZONTAL WHEN MACHINE IS OUT OF LEVEL.

DO NOT DEPEND ON TILT ALARM AS A LEVEL INDICATOR FOR THE CHASSIS.

TO AVOID TIP OVER, LOWER PLATFORM TO GROUND LEVEL. THEN DRIVE MACHINE TO A LEVEL SURFACE BEFORE RAISING BOOM.

TO AVOID SERIOUS INJURY, DO NOT OPERATE MACHINE IF ANY CONTROL LEVER OR TOGGLE SWITCH CONTROLLING PLATFORM MOVEMENT DOES NOT RETURN TO THE 'OFF' OR NEUTRAL POSITION WHEN RELEASED.

IF THE PLATFORM DOES NOT STOP WHEN A CONTROL SWITCH OR LEVER IS RELEASED, REMOVE FOOT FROM FOOTSWITCH OR USE EMERGENCY STOP SWITCH TO STOP THE MACHINE.

Swinging the Boom

To swing boom, use SWING control switch to select RIGHT or LEFT direction.

NOTICE

WHEN SWINGING THE BOOM MAKE SURE THERE IS AMPLE ROOM FOR THE BOOM TO CLEAR SURROUNDING WALLS, PARTITIONS AND EQUIPMENT.

NOTE: *When boom functions are being operated there an interlock prevents the use of DRIVE and STEER functions.*

Raising and Lowering the Tower Boom

This machine will have two controls for the tower boom (two toggle switches), one controls tower lift, the other tower telescope. The switching system will sequence its LIFT and TELESCOPE functions as follows:

1. Sequence while RAISING the TOWER BOOM from the fully lowered position.
 - a. The TOWER BOOM must be fully elevated “up” (approximately 13 degrees from vertical) before the TOWER BOOM can be extended from the fully retracted position.
 - b. The TOWER TELESCOPE “out” or “in” will only be operable when the TOWER BOOM is fully elevated “up”.
2. Sequence while LOWERING the TOWER BOOM from the fully elevated “up” position.
 - a. Operate TOWER TELESCOPE “in” until TOWER BOOM is fully retracted. (TOWER must not lift “down until boom is telescoped ”in” or “up” fully.
 - b. The TOWER lift “down” will only operate when the TOWER BOOM is fully retracted.

⚠ WARNING

TO AVOID TILTING MACHINE IF TOWER BOOM SWITCHING MALFUNCTIONS:

— LOWER PLATFORM TO GROUND USING MAIN BOOM LIFT AND TELESCOPE FUNCTIONS.

— HAVE CONDITION CORRECTED BY A CERTIFIED JLG SERVICE TECHNICIAN BEFORE CONTINUING USE OF MACHINE.

Raising and Lowering the Main Boom

To raise and lower Main Boom, position MAIN LIFT control switch or controller to UP OR DOWN and hold until desired height is reached.

Telescoping the Main Boom

To extend or retract Main Boom, position MAIN TELESCOPE control switch to IN or OUT and hold until platform reaches desired position.

4.8 SHUT DOWN AND PARK

1. Drive machine to a protected area.
2. Assure main boom is fully retracted and lowered over rear (Drive) axle; all access panels and doors closed and secured.
3. Remove all load and allow engine to operate 3-5 minutes at LOW setting to permit reduction of engine internal temperatures.
4. At Ground Controls, turn KEY SELECT switch to (center) OFF. Position, POWER/EMERGENCY STOP switch (down) to OFF. Remove key.
5. Cover Platform Control console to protect instruction placards, warning decals and operating controls from hostile environment.

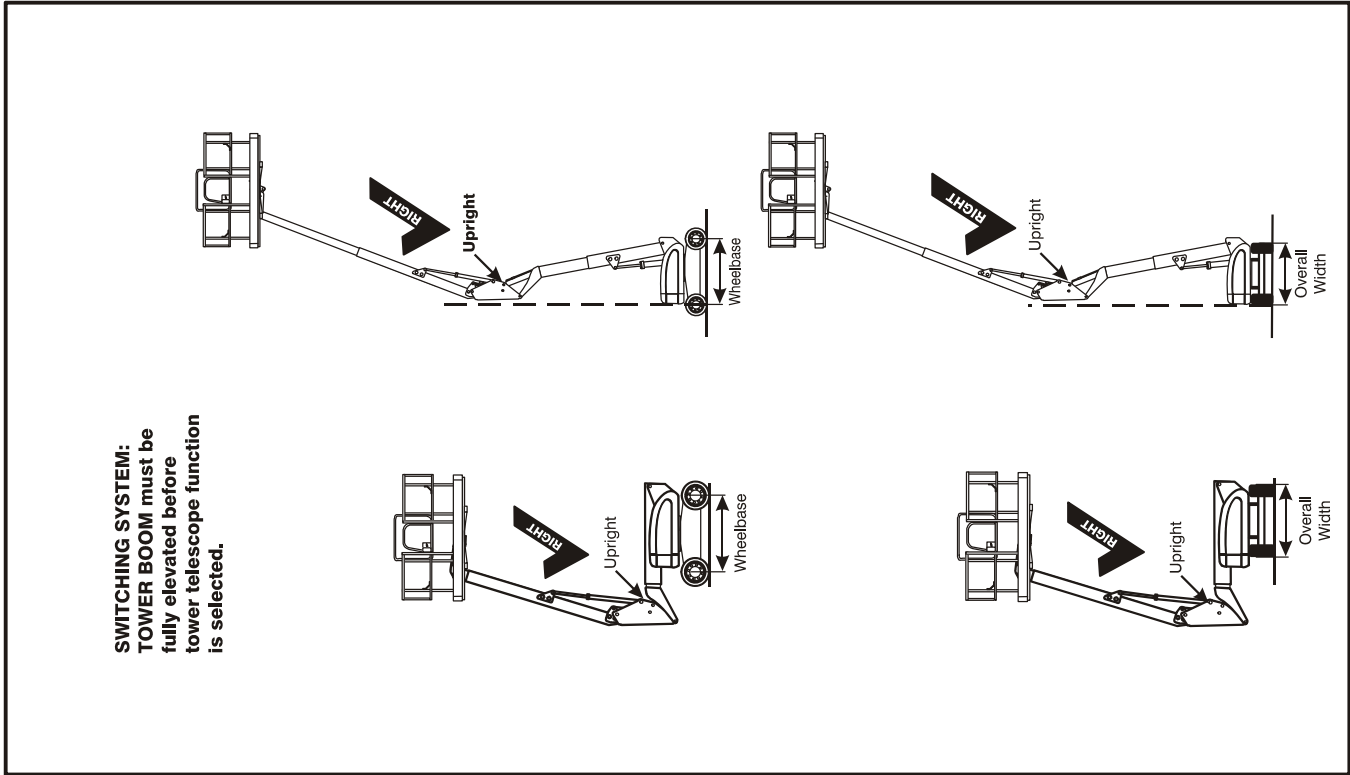

Figure 4-4. Boom Upright Positioning - Sheet 1 of 2

WARNING

TO AVOID TIPPING OVER IF THIS OCCURS:
— LOWER PLATFORM TO GROUND VIA MAIN BOOM LIFT AND TELESCOPE FUNCTIONS. HAVE CONDITION CORRECTED BY A CERTIFIED JLG SERVICE TECHNICIAN BEFORE CONTINUING USE OF MACHINE.

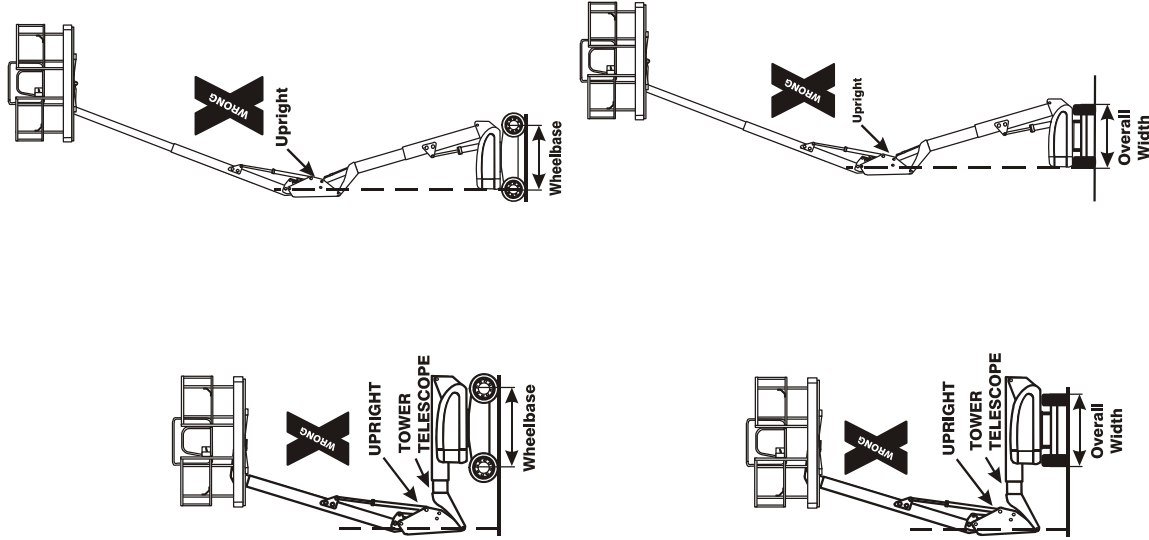

Figure 4-5. Boom Upright Positioning - Sheet 2 of 2

4.9 OSCILLATING AXLE LOCKOUT TEST (IF EQUIPPED)

NOTICE

LOCKOUT SYSTEM TEST MUST BE PERFORMED QUARTERLY, ANY TIME A SYSTEM COMPONENT IS REPLACED, OR WHEN IMPROPER SYSTEM OPERATION IS SUSPECTED.

Refer to Section 6.5, Oscillating Axle Lockout Test (If Equipped) for procedure.

4.10 STEER/TOW SELECTOR (IF EQUIPPED)

(See Figure 4-6.)

WARNING

DO NOT ATTEMPT TO TOW MACHINE UNLESS EQUIPPED WITH COMPLETE TOW PACKAGE FROM MANUFACTURER.

A push-pull type selector valve located adjacent to the steer cylinder and linkage regulates oil flow in the steer circuit for steering and towing. When steering the unit the valve knob is pushed IN. When towing the unit the valve knob is pulled OUT to the float position.

4.11 TOWING (IF EQUIPPED)

WARNING

RUNAWAY VEHICLE/MACHINE HAZARD. MACHINE HAS NO TOWING BRAKES. TOWING VEHICLE MUST BE ABLE TO CONTROL MACHINE AT ALL TIMES. ON-HIGHWAY TOWING NOT PERMITTED. FAILURE TO FOLLOW INSTRUCTIONS COULD CAUSE SERIOUS INJURY OR DEATH.

MAXIMUM TOWING SPEED 10 M.P.H. (16 K.M.H.)

MAXIMUM TOWING GRADE 25%.

Prior to towing the machine, complete the following:

CAUTION

DO NOT TOW MACHINE WITH ENGINE OPERATING OR DRIVE HUBS ENGAGED.

1. Retract, lower and position boom over rear drive wheels in line with direction of travel; lock turntable.
2. Connect tow bar to front of frame with attach pins, and tow bar to towing vehicle.

⚠ WARNING

**RUNAWAY VEHICLE/
MACHINE HAZARD**

MACHINE HAS NO TOWING BRAKES. TOWING VEHICLE MUST BE ABLE TO CONTROL MACHINE AT ALL TIMES. ON-HIGHWAY TOWING NOT PERMITTED. FAILURE TO FOLLOW INSTRUCTIONS COULD CAUSE SERIOUS INJURY OR DEATH.

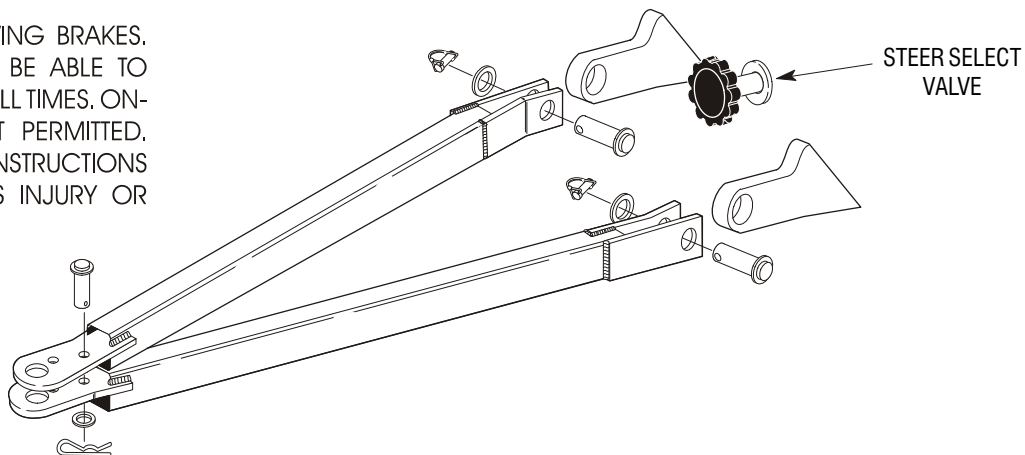

Figure 4-6. Towbar Connecting Points - Prior to S/N 81836

⚠ WARNING

**RUNAWAY VEHICLE/
MACHINE HAZARD**

MACHINE HAS NO TOWING BRAKES. TOWING VEHICLE MUST BE ABLE TO CONTROL MACHINE AT ALL TIMES. ON-HIGHWAY TOWING NOT PERMITTED. FAILURE TO FOLLOW INSTRUCTIONS COULD CAUSE SERIOUS INJURY OR DEATH.

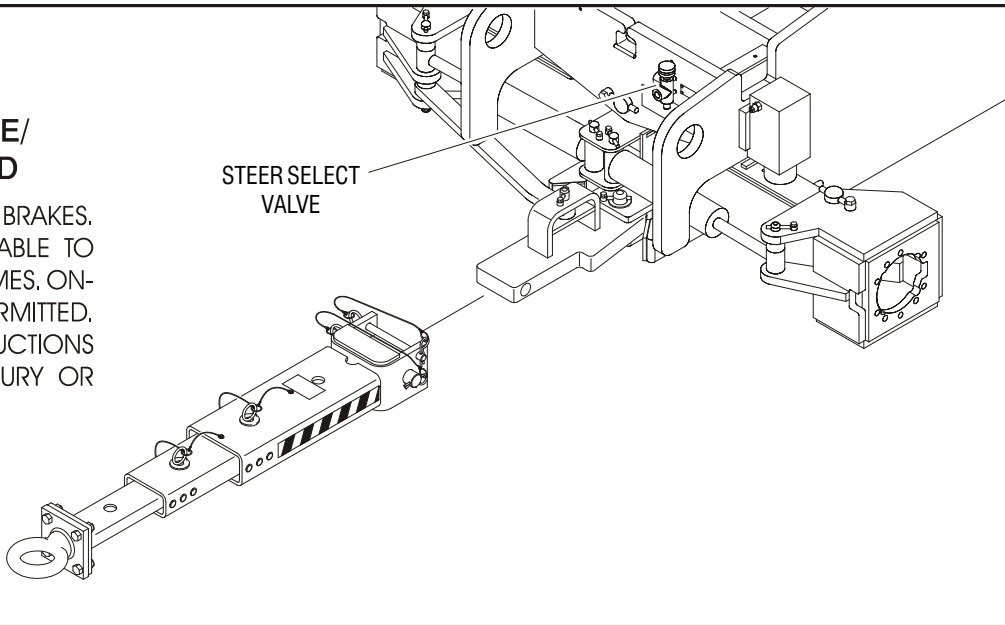

Figure 4-7. Towbar Connecting Points - S/N 81836 to Present

SECTION 4 - MACHINE OPERATION

3. Disconnect drive hubs by inverting disconnect cap.
4. Actuate steer/tow selector valve for towing; pull valve knob OUT to float position. (This opens the steer circuit to reservoir, allowing the steer cylinder rod free travel.)
The machine is now in the towing mode.

After towing the machine, complete the following:

1. Actuate steer/tow selector valve for steering; push valve knob IN to the actuated position.
2. Reconnect drive hubs by inverting disconnect cap.
3. Disconnect tow bar from steering hitch and from towing vehicle. The machine is now in the driving mode.

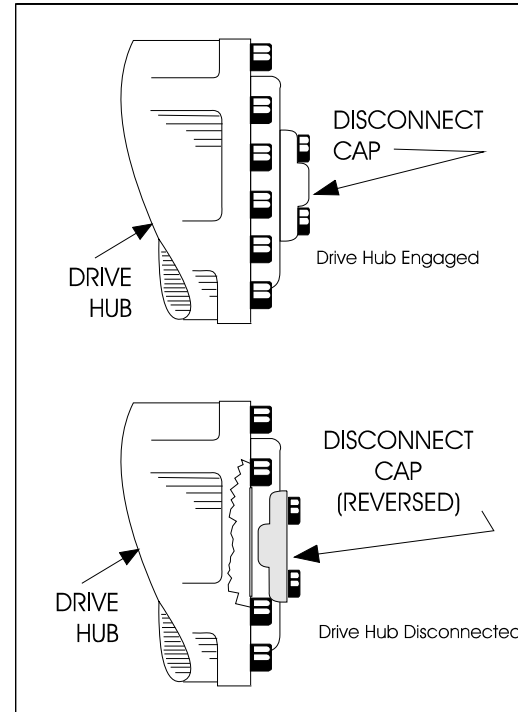

Figure 4-8. Drive Disconnect Hub

4.12 AUXILIARY POWER - NON ADE EQUIPPED MACHINES



WHEN OPERATING ON AUXILIARY POWER, DO NOT OPERATE MORE THAN ONE FUNCTION AT A TIME. (SIMULTANEOUS OPERATION CAN OVERLOAD THE 12-VOLT AUXILIARY PUMP MOTOR.)

A toggle type auxiliary power control switch is located on the platform control station and another is located on the ground control station. Operation of either switch turns on the electrically driven auxiliary hydraulic pump. This should be used in case of failure of the main power plant. The auxiliary pump will operate boom lift, telescope and swing. To activate auxiliary power:

Activating from the Platform Control Station

1. Position PLATFORM/GROUND SELECT KEY SWITCH to PLATFORM.
2. Position POWER/EMERGENCY STOP switch to ON.
3. Depress and hold footswitch.
4. Operate appropriate control switch, lever or controller for desired function and hold.

5. Position AUXILIARY POWER switch to ON and hold.
6. Release AUXILIARY POWER switch, selected control switch, lever or controller, and footswitch.
7. Position POWER/EMERGENCY STOP switch to OFF.

Activating from the Ground Control Station

1. Position PLATFORM/GROUND SELECT KEY SWITCH to GROUND.
2. Position POWER/EMERGENCY STOP switch to ON.
3. Operate appropriate control switch or controller for desired function and hold.
4. Position AUXILIARY POWER switch to ON and hold.
5. Release AUXILIARY POWER switch, and appropriate control switch or controller.
6. Position POWER/EMERGENCY STOP switch to OFF.

4.13 AUXILIARY POWER - ADE EQUIPPED MACHINES

CAUTION

WHEN OPERATING ON AUXILIARY POWER, DO NOT OPERATE MORE THAN ONE FUNCTION AT A TIME. (SIMULTANEOUS OPERATION CAN OVERLOAD THE 12-VOLT AUXILIARY PUMP MOTOR.)

A toggle type auxiliary power control switch is located on the platform control station and another is located on the ground control station. Operation of either switch turns on the electrically driven auxiliary hydraulic pump. This should be used in case of failure of the main power plant. The auxiliary pump will operate boom lift, telescope and swing. To activate auxiliary power:

Activating from the Platform Control Station

1. Position PLATFORM/GROUND SELECT KEY SWITCH to PLATFORM.
2. Position POWER/EMERGENCY STOP switch to ON.
3. Depress and hold footswitch.
4. Position AUXILIARY POWER switch to ON and hold.

5. Operate appropriate control switch, lever or controller for desired function and hold.
6. Release AUXILIARY POWER switch, selected control switch, lever or controller, and footswitch.
7. Position POWER/EMERGENCY STOP switch to OFF.

Activating from the Ground Control Station

1. Position PLATFORM/GROUND SELECT KEY SWITCH to GROUND.
2. Position POWER/EMERGENCY STOP switch to ON.
3. Position AUXILIARY POWER switch to ON and hold.
4. Operate appropriate control switch or controller for desired function and hold.
5. Release AUXILIARY POWER switch, and appropriate control switch or controller.
6. Position POWER/EMERGENCY STOP switch to OFF.

4.14 DUAL FUEL SYSTEM (GAS ENGINE ONLY)

The dual fuel system enables the standard gasoline engine to run on either gasoline or LP gas.



IT IS POSSIBLE TO SWITCH FROM ONE FUEL SOURCE TO THE OTHER WITHOUT ALLOWING THE ENGINE TO STOP. EXTREME CARE MUST BE TAKEN AND THE FOLLOWING INSTRUCTIONS MUST BE FOLLOWED.

Changing From Gasoline to LP Gas

1. Start engine from Ground Control Station.
2. Open hand valve on LP gas supply tank by turning counterclockwise.
3. While engine is operating on GASOLINE under a no-load condition, place FUEL SELECT switch at Platform Control to LP position.

Changing From LP Gas to Gasoline

1. With engine operating on LP under a no-load condition, position FUEL SELECT switch at Platform Control Station to GASOLINE position.
2. Close hand valve on LP gas supply tank by turning clockwise.

4.15 RE-SYNCHRONIZE THE LOWER LIFT CYLINDER

Level Override Valve

A pull type control valve allows the operator to adjust the tower lift cylinder and the upright cylinder if the upright cylinder is not fully retracted when boom is in the stowed position. This valve is located in the engine compartment area.

To Operate:

1. Pull the red knob
2. Using the ground control raise the lower boom 6 feet.
3. Release the knob.
4. Fully lower the boom.
5. Repeat if necessary.

4.16 TIE DOWN AND LIFTING

When transporting machine, boom must be in the stowed mode with turntable lock pin engaged and machine securely tied down to truck or trailer deck. Four tie down eyes are provided in the frame slab, one at each corner of the machine. (See Figure 4-9. Machine Tie Down.)

If it becomes necessary to lift the machine using an overhead or mobile crane, it is very important that the lifting devices are attached only to the designated lifting eyes, and that the turntable lock pin is engaged. (See Figure 4-10. Lifting Chart.)

NOTE: *Lifting eyes are provided at the front and rear in the frame slab. Each of the four chains or slings used for lifting machine must be adjusted individually so machine remains level when elevated.*

NOTICE

SECURE TURNTABLE WITH TURNTABLE LOCK BEFORE TRAVELING LONG DISTANCES OR HAULING MACHINE ON TRUCK/TRAILER.

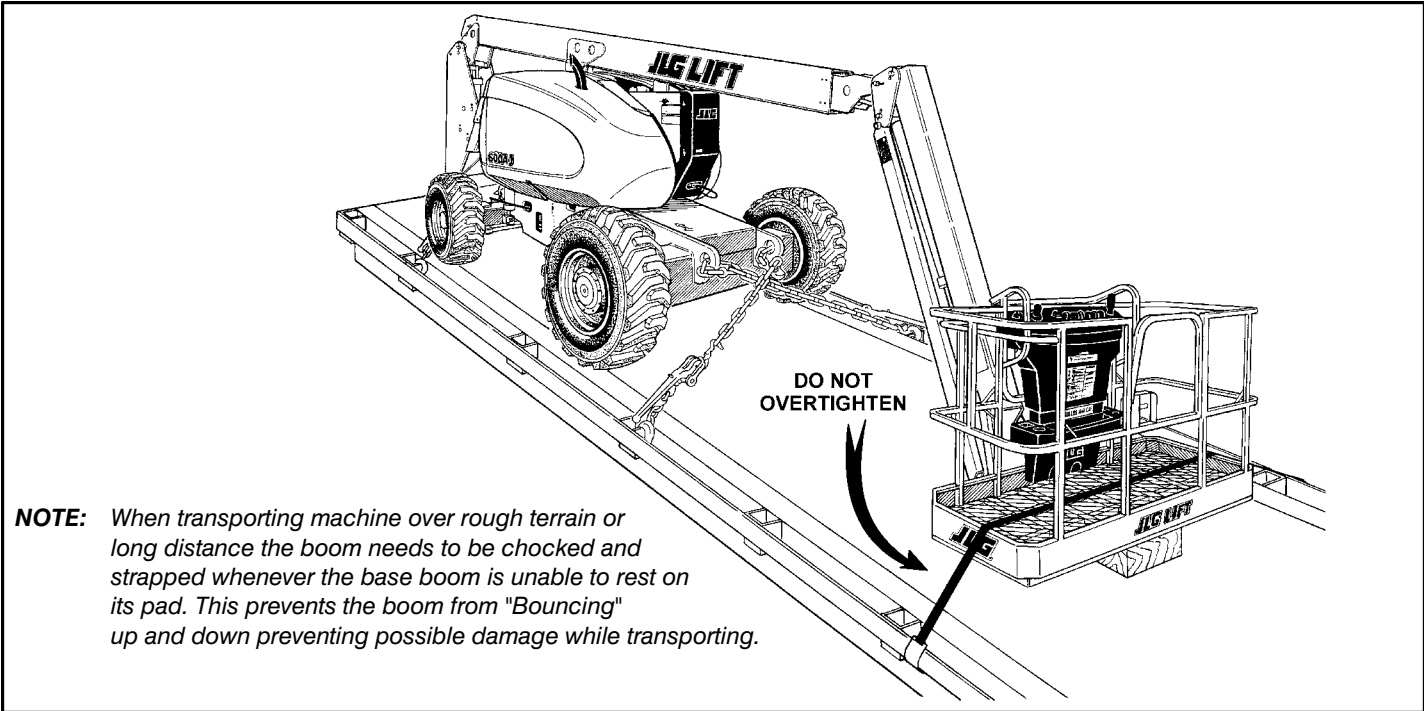

Figure 4-9. Machine Tie Down

SECTION 4 - MACHINE OPERATION

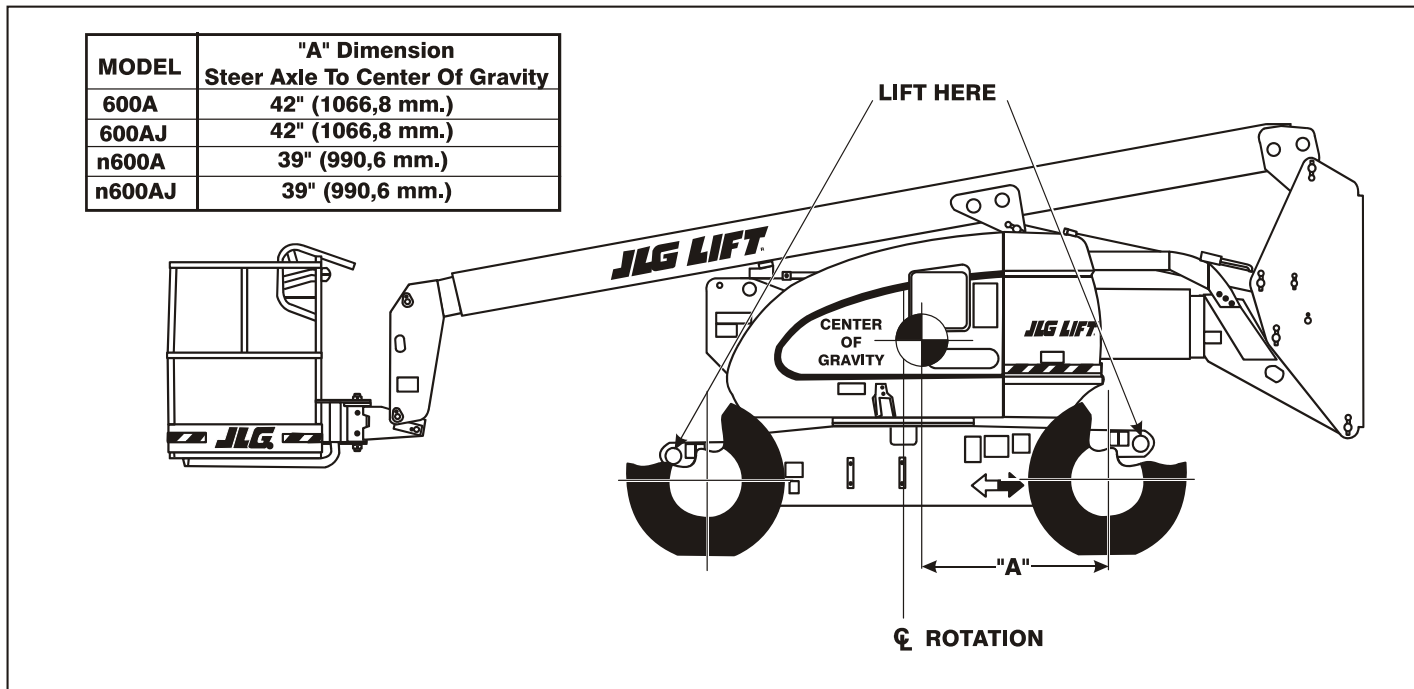

Figure 4-10. Lifting Chart

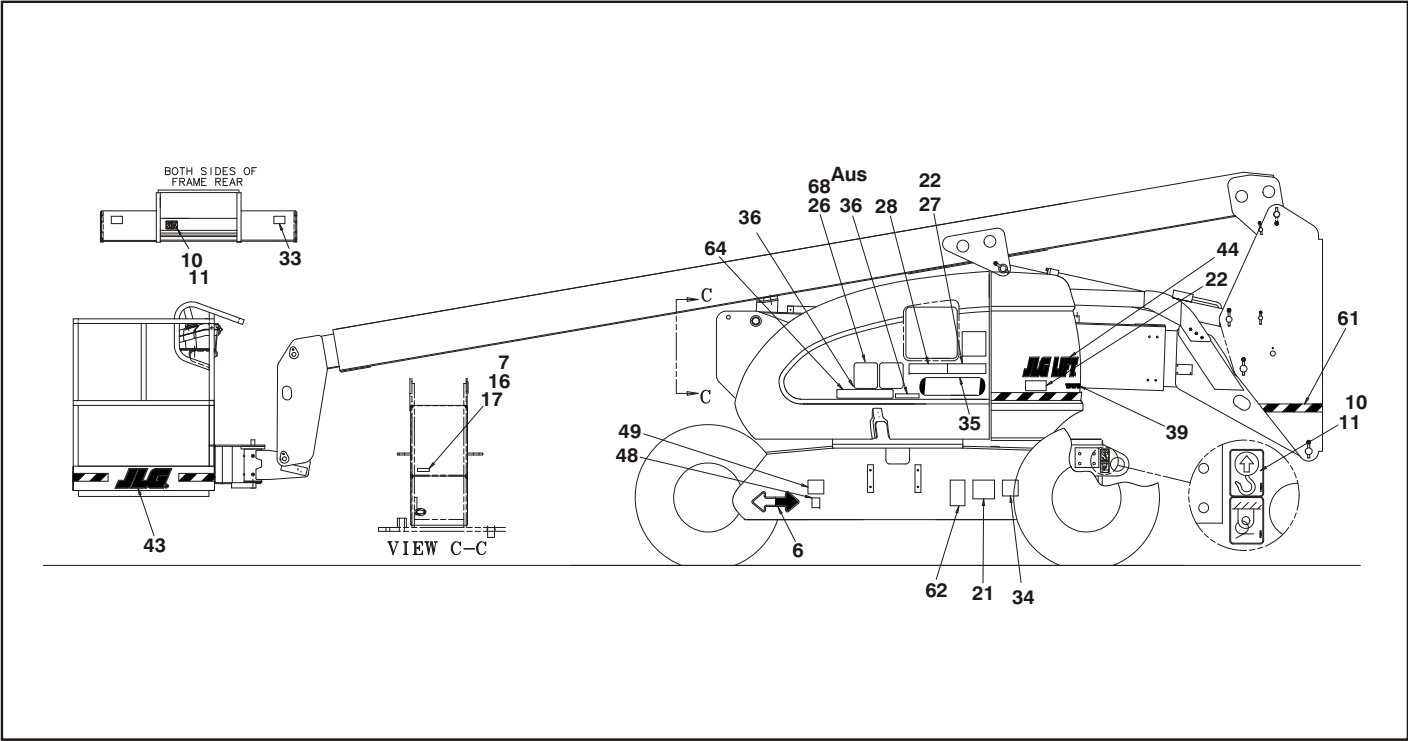

Figure 4-11. 600A & 600AJ Decal Installation - Sheet 1 of 4

SECTION 4 - MACHINE OPERATION

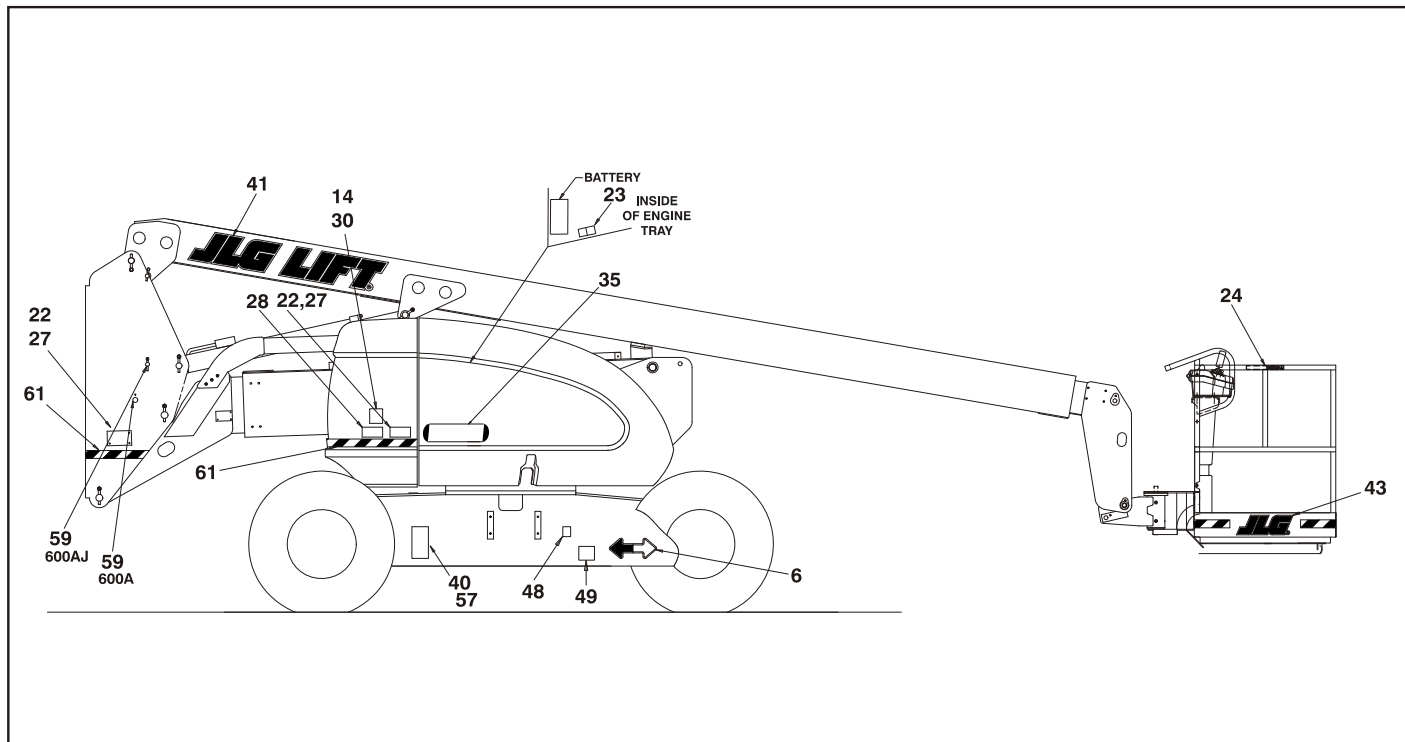

Figure 4-12. 600A & 600AJ Decal Installation - Sheet 2 of 4

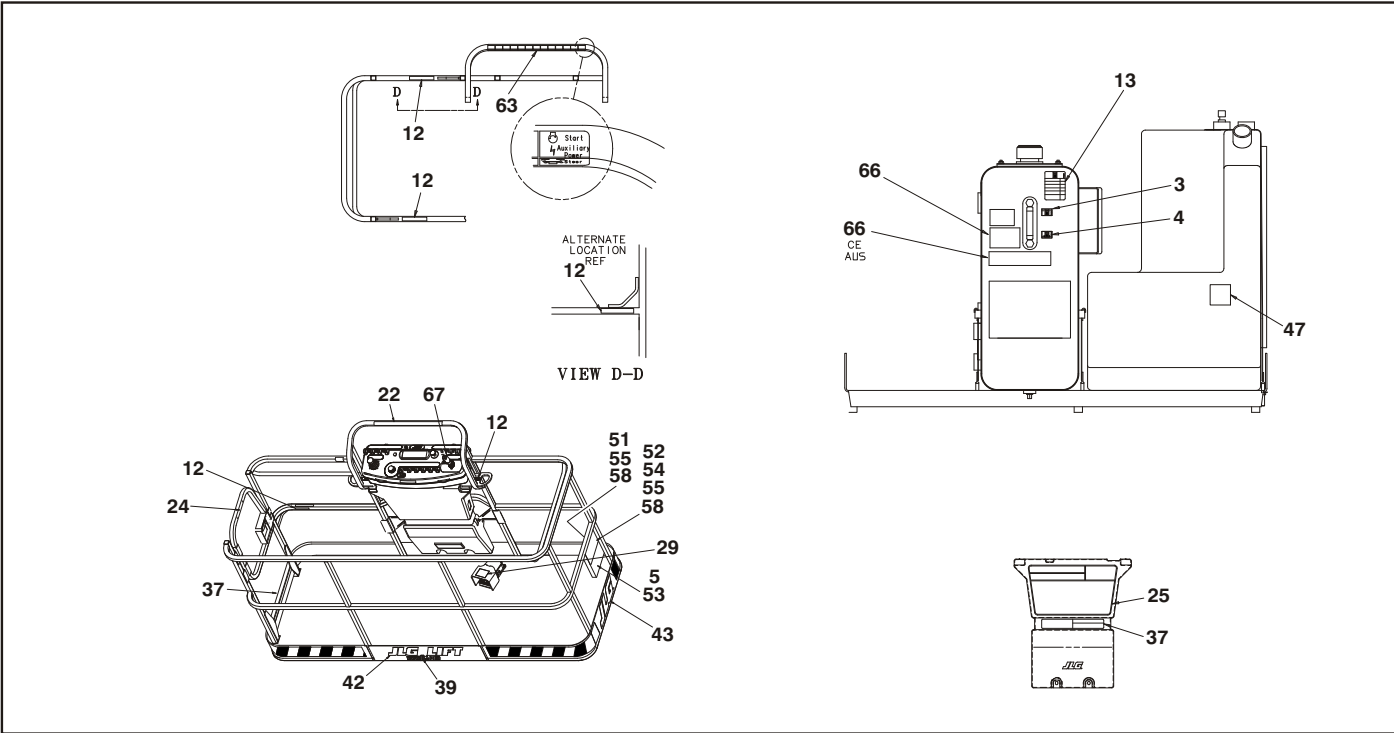

Figure 4-13. 600A & 600AJ Decal Installation - Sheet 3 of 4

SECTION 4 - MACHINE OPERATION

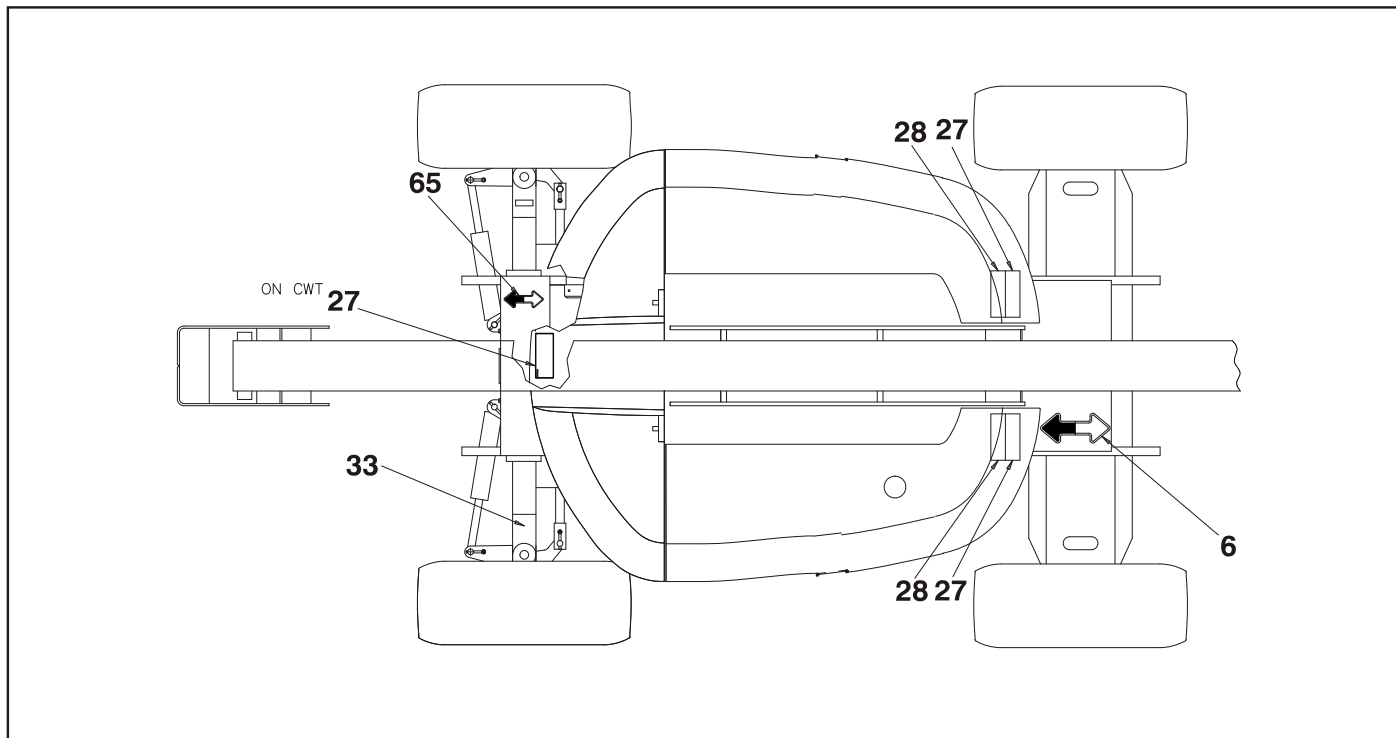

Figure 4-14. 600A & 600AJ Decal Installation - Sheet 4 of 4

Table 4-1. 600A Decal Legend - Prior to S/N 0300140401

Item #	ANSI 0273891-9	Canadian French 0273893-9	CE 0273895-5	Spanish 0273899-9	Portuguese 0273901-9	Japanese 0273903-10	Australian 1001114388-1
1	--	--	--	--	--	--	--
2	1701499	1701499	1701499	1701499	1701499	1701499	1701499
3	--	--	--	--	--	--	--
4	--	--	--	--	--	--	--
5	1701509	1701509	1701509	1701509	1701509	1701509	1701509
6	1701529	1701529	1701529	1701529	1701529	1701529	1701529
7	--	--	--	--	--	--	--
8	--	--	--	--	--	--	--
9	--	--	--	--	--	--	--
10	1703811	1703811	1703811	1703811	1703811	1703811	1703811
11	1703814	1703814	1703814	1703814	1703814	1703814	1703814
12	1704277	1704277	1704277	1704277	1704277	1704277	1704277
13	1704412	1704412	1704412	1704412	1704412	1704412	1704412
14	--	--	--	--	--	--	1705084
15	--	1705514	1705514	--	--	--	1705514
16	--	--	--	--	--	--	--

SECTION 4 - MACHINE OPERATION

Table 4-1. 600A Decal Legend - Prior to S/N 0300140401

Item #	ANSI 0273891-9	Canadian French 0273893-9	CE 0273895-5	Spanish 0273899-9	Portuguese 0273901-9	Japanese 0273903-10	Australian 1001114388-1
17	3251243	3251243	--	3251243	--	3251243	--
18	--	--	--	--	--	--	--
19	--	--	--	--	--	--	--
20	--	--	--	--	--	--	--
21	--	1704006	--	1704007	1705901		--
22	1703953	1703942	--	1703941	1705903	1703944	--
23	--	--	--	--	--	--	--
24	1702868	1704000	--	1704001	1705967	--	--
25	1703797	1703924	1705921	1703923	1705895	1703926	1705921
26	1705336	1705347	1705822	1705917	1705896	1705344	1705822
27	1703804	1703948	1701518	1703947	1705898	1703950	1701518
28	1703805	1703936	1705961	1703935	1705897	1703938	1705961
29		1703984	1705828	1703983	1705902	1703980	1705828
30	3251813	3251813	--	3251813	3251813	3251813	--
31	--	--	--	--	--	--	--
32	--	--	--	--	--	--	--
33	1703469	1703469	1703469	1703469	1703469	1703469	1703469
34	1702631	1702631	--	1702631	1702631	1702631	1702631

SECTION 4 - MACHINE OPERATION

Table 4-1. 600A Decal Legend - Prior to S/N 0300140401

Item #	ANSI 0273891-9	Canadian French 0273893-9	CE 0273895-5	Spanish 0273899-9	Portuguese 0273901-9	Japanese 0273903-10	Australian 1001114388-1
35	1702818	1702818	1702818	1702818	1702818	1702818	1702818
36	1707014	1707046	1705978	1707048	1707051	1707053	1705978
37	1704096	1704099	1705978	1704098	1706380	1704102	1705978
38	--	--	--	--	--	--	--
39	1704885	1704885	1704885	1704885	1704885	1704885	1704885
40	1706948	1706948	--	1706948	1706948	1706948	--
41	--	--	--	--	--	--	--
42	--	--	--	--	--	--	--
43	--	--	--	--	--	--	--
44	--	--	--	--	--	--	--
45	--	--	--	--	--	--	--
46	--	--	--	--	--	--	--
47	--	--	--	--	--	--	--
48	--	--	--	--	--	--	--
49	--	--	--	--	--	--	--
50	--	--	--	--	--	--	--
51	--	--	--	--	--	--	--
52	--	--	--	--	--	--	--

SECTION 4 - MACHINE OPERATION

Table 4-1. 600A Decal Legend - Prior to S/N 0300140401

Item #	ANSI 0273891-9	Canadian French 0273893-9	CE 0273895-5	Spanish 0273899-9	Portuguese 0273901-9	Japanese 0273903-10	Australian 1001114388-1
53	--	--	--	--	--	--	--
54	--	--	--	--	--	--	--
55	--	--	--	--	--	--	--
56	--	--	--	--	--	--	--
57	--	--	--	--	--	--	--
58	--	--	--	--	--	--	--
59	--	--	--	--	--	--	--
60	--	--	--	--	--	--	--
61	--	--	--	--	--	--	--
62	1700584	1700584	1700584	1702573	1700584	1700584	1700584
63	1001108493	1001108493	--	1001108493	1001108493	1001108493	--
64	1706941	1706941	--	1706941	1706941	1706941	--
65	1703687	1703687	1703687	1703687	1703687	1703687	1703687
66	1702265	1703990	1705977	1702617	1703544	1702271	1705977
67	1705351	1705429	--	1705910	1705905	1705426	--
68	--	--	--	--	--	--	1001112551

SECTION 4 - MACHINE OPERATION

Table 4-2. 600A Decal Legend - S/N 0300140401 to Present

Item #	ANSI 0273891-10	Canadian French 0273893-9	CE 0273895-6	Spanish 0273899-10	Portuguese 0273901-9	Japanese 0273903-11	Australian 1001114388-1	Chinese Simplified 1001116840-3	Chinese Traditional 1001116841-3
1	--	--	--	--	--	--	--	--	--
2	1701499	1701499	1701499	1701499	1701499	1701499	1701499	1701499	1701499
3	--	--	--	--	--	--	--	--	--
4	--	--	--	--	--	--	--	--	--
5	1701509	1701509	1701509	1701509	1701509	1701509	1701509	1701509	1701509
6	1701529	1701529	1701529	1701529	1701529	1701529	1701529	1701529	1701529
7	--	--	--	--	--	--	--	--	--
8	--	--	--	--	--	--	--	--	--
9	--	--	--	--	--	--	--	--	--
10	1703811	1703811	1703811	1703811	1703811	1703811	1703811	1703811	1703811
11	1703814	1703814	1703814	1703814	1703814	1703814	1703814	1703814	1703814
12	1704277	1704277	1704277	1704277	1704277	1704277	1704277	1704277	1704277
13	1704412	1704412	1704412	1704412	1704412	1704412	1704412	1704412	1704412
14	--	--	--	--	--	--	1705084	1705084	1705084
15	--	1705514	1705514	--	--	--	1705514	1705514	1705514
16	--	--	--	--	--	--	--	--	--

SECTION 4 - MACHINE OPERATION

Table 4-2. 600A Decal Legend - S/N 0300140401 to Present

Item #	ANSI 0273891-10	Canadian French 0273893-9	CE 0273895-6	Spanish 0273899-10	Portuguese 0273901-9	Japanese 0273903-11	Australian 1001114388-1	Chinese Simplified 1001116840-3	Chinese Traditional 1001116841-3
17	3251243	3251243	--	3251243	--	3251243	--	--	--
18	--	--	--	--	--	--	--	--	--
19	--	--	--	--	--	--	--	--	1001117034
20	--	--	--	--	--	--	--	--	1001117035
21	--	1704006	--	1704007	1705901	--	--	--	--
22	1703953	1703942	--	1703941	1705903	1703944	--	1001116845	1703943
23	--	--	--	--	--	--	--	--	--
24	1702868	1704000	--	1704001	1705967	--	--	1706968	1001116846
25	1703797	1703924	1705921	1703923	1705895	1703926	1705921	1001116847	1703925
26	1705336	1705347	1705822	1705917	1705896	1705344	1705822	1001116848	1001116849
27	1703804	1703948	1701518	1703947	1705898	1703950	1701518	1001116850	1703949
28	1703805	1703936	1705961	1703935	1705897	1703938	1705961	1703937	1001116851
29		1703984	1705828	1703983	1705902	1703980	1705828	1001116852	1703982
30	3251813	3251813	--	3251813	3251813	3251813	--	3251813	3251813
31	--	--	--	--	--	--	--	--	--
32	--	--	--	--	--	--	--	--	--
33	1703469	1703469	1703469	1703469	1703469	1703469	1703469	1703469	1703469
34	1702631	1702631	--	1702631	1702631	1702631	1702631	1702631	1702631

SECTION 4 - MACHINE OPERATION

Table 4-2. 600A Decal Legend - S/N 0300140401 to Present

Item #	ANSI 0273891-10	Canadian French 0273893-9	CE 0273895-6	Spanish 0273899-10	Portuguese 0273901-9	Japanese 0273903-11	Australian 1001114388-1	Chinese Simplified 1001116840-3	Chinese Traditional 1001116841-3
35	1702818	1702818	1702818	1702818	1702818	1702818	1702818	1702818	1702818
36	1001121813	1001121815	1705978	1001121817	1001121819	1001121820	1705978	1001121824	1001121822
37	1001121800	1001121802	1705978	1001121804	1001121806	1001121807	1705978	1001121811	1001121809
38	--	--	--	--	--	--	--	--	--
39	1704885	1704885	1704885	1704885	1704885	1704885	1704885	1704885	1704885
40	1706948	1706948	--	1706948	1706948	1706948	--	--	--
41	--	--	--	--	--	--	--	--	--
42	--	--	--	--	--	--	--	--	--
43	--	--	--	--	--	--	--	--	--
44	--	--	--	--	--	--	--	--	--
45	--	--	--	--	--	--	--	--	--
46	--	--	--	--	--	--	--	--	--
47	--	--	--	--	--	--	--	--	--
48	--	--	--	--	--	--	--	--	--
49	--	--	--	--	--	--	--	--	--
50	--	--	--	--	--	--	--	--	--
51	--	--	--	--	--	--	--	--	--
52	--	--	--	--	--	--	--	--	--

SECTION 4 - MACHINE OPERATION

Table 4-2. 600A Decal Legend - S/N 0300140401 to Present

Item #	ANSI 0273891-10	Canadian French 0273893-9	CE 0273895-6	Spanish 0273899-10	Portuguese 0273901-9	Japanese 0273903-11	Australian 1001114388-1	Chinese Simplified 1001116840-3	Chinese Traditional 1001116841-3
53	--	--	--	--	--	--	--	--	--
54	--	--	--	--	--	--	--	--	--
55	--	--	--	--	--	--	--	--	--
56	--	--	--	--	--	--	--	--	--
57	--	--	--	--	--	--	--	--	--
58	--	--	--	--	--	--	--	--	--
59	--	--	--	--	--	--	--	--	--
60	--	--	--	--	--	--	--	--	--
61	--	--	--	--	--	--	--	--	--
62	1700584	1700584	1700584	1702573	1700584	1700584	1700584	1700584	1700584
63	1001108493	1001108493	--	1001108493	1001108493	1001108493	--	1001108493	1001108493
64	1706941	1706941	--	1706941	1706941	1706941	--	1706941	1706941
65	1703687	1703687	1703687	1703687	1703687	1703687	1703687	1703687	1703687
66	1702265	1703990	1705977	1702617	1703544	1702271	1705977	1001116861	1001116862
67	1705351	1705429	--	1705910	1705905	1705426	--	1705430	1001116863
68	--	--	--	--	--	--	1001112551	--	--

SECTION 4 - MACHINE OPERATION**Table 4-3. 600AJ Decal Legend - Prior to S/N 0300140401**

Item #	ANSI 0273892-10	Canadian French 0273894-9	CE 0273896-5	Spanish 0273900-10	Portuguese 0273902-9	Japanese 0273904-11	Australian 1001114389-1
1	--	--	--	--	--	--	--
2	1701499	1701499	1701499	1701499	1701499	1701499	1701499
3	--	--	--	--	--	--	--
4	--	--	--	--	--	--	--
5	1701509	1701509	1701509	1701509	1701509	1701509	1701509
6	1701529	1701529	1701529	1701529	1701529	1701529	1701529
7	--	--	--	--	--	--	--
8	--	--	--	--	--	--	--
9	--	--	--	--	--	--	--
10	1703811	1703811	1703811	1703811	1703811	1703811	1703811
11	1703814	1703814	1703814	1703814	1703814	1703814	1703814
12	1704277	1704277	1704277	1704277	1704277	1704277	1704277
13	1704412	1704412	1704412	1704412	1704412	1704412	1704412
14	--	--	--	--	--	--	1705084
15	--	--	--	--	--	--	1705514
16	--	--	--	--	--	--	--
17	3251243	3251243	3251243	3251243	--	3251243	--

SECTION 4 - MACHINE OPERATION

Table 4-3. 600AJ Decal Legend - Prior to S/N 0300140401

Item #	ANSI 0273892-10	Canadian French 0273894-9	CE 0273896-5	Spanish 0273900-10	Portuguese 0273902-9	Japanese 0273904-11	Australian 1001114389-1
18	--	--	--	--	--	--	--
19	--	--	--	--	--	--	--
20	--	--	--	--	--	--	--
21	--	1704006	--	1704007	1705901	--	--
22	1703953	1703942	--	1703941	1705903	1703944	--
23	--	--	--	--	--	--	--
24	1702868	1704000	--	1704001	1705967	--	--
25	1703797	1703924	1705921	1703923	1705895	1703926	1705921
26	1705336	1705347	1705822	1705917	1705896	1705344	1705822
27	1703804	1703948	1701518	1703947	1705898	1703950	1701518
28	1703805	1703936	1705961	1703935	1705897	1703938	1705961
29	--	1703984	1705828	1703983	1705902	1703980	1705828
30	3251813	3251813	--	3251813	3251813	3251813	--
31	--	--	--	--	--	--	--
32	--	--	--	--	--	--	--
33	1703469	1703469	1703469	1703469	1703469	1703469	1703469
34	1702631	1702631	1702631	1702631	1702631	1702631	1702631
35	1702819	1702819	1702819	1702819	1702819	1702819	1702819

Table 4-3. 600AJ Decal Legend - Prior to S/N 0300140401

Item #	ANSI 0273892-10	Canadian French 0273894-9	CE 0273896-5	Spanish 0273900-10	Portuguese 0273902-9	Japanese 0273904-11	Australian 1001114389-1
36	1707013	1707046	1705978	1707049	1707052	1707054	1705978
37	1701645	1703996	1705978	1707056	1707057	1707059	1705978
38	--	--	--	--	--	--	--
39	1704885	1704885	1704885	1704885	1704885	1704885	1704885
40	1706948	1706948	--	1706948	1706948	1706948	--
41	--	--	--	--	--	--	--
42	--	--	--	--	--	--	--
43	--	--	--	--	--	--	--
44	--	--	--	--	--	--	--
45	--	--	--	--	--	--	--
46	--	--	--	--	--	--	--
47	--	--	--	--	--	--	--
48	--	--	--	--	--	--	--
49	--	--	--	--	--	--	--
50	--	--	--	--	--	--	--
51	--	--	--	--	--	--	--
52	--	--	--	--	--	--	--
53	--	--	--	--	--	--	--

SECTION 4 - MACHINE OPERATION

Table 4-3. 600AJ Decal Legend - Prior to S/N 0300140401

Item #	ANSI 0273892-10	Canadian French 0273894-9	CE 0273896-5	Spanish 0273900-10	Portuguese 0273902-9	Japanese 0273904-11	Australian 100114389-1
54	--	--	--	--	--	--	--
55	--	--	--	--	--	--	--
56	--	--	--	--	--	--	--
57	--	--	--	--	--	--	--
58	--	--	--	--	--	--	--
59	--	--	--	--	--	--	--
60	--	--	--	--	--	--	--
61	--	--	--	--	--	--	--
62	1700584	1700584	1700584	1702573	1700584	1700584	1700584
63	1001108493	1001108493	--	1001108493	1001108493	1001108493	--
64	1706941	1706941	--	1706941	1706941	1706941	--
65	1703687	1703687	1703687	1703687	1703687	1703687	1703687
66	1702265	1703990	1705977	1702617	1703544	1702271	1705977
67	1705351	1705429	--	1705910	1705905	1705426	--
68	--	--	--	--	--	--	1001112551

SECTION 4 - MACHINE OPERATION

Table 4-4. 600AJ Decal Legend - S/N 0300140401 to Present

Item #	ANSI 0273892-10	Canadian French 0273894-9	CE 0273896-5	Spanish 0273900-10	Portuguese 0273902-9	Japanese 0273904-11	Australian 1001114389-1	Chinese Simplified 1001116842-3	Chinese Traditional 1001116843-3
1	--	--	--	--	--	--	--	--	--
2	1701499	1701499	1701499	1701499	1701499	1701499	1701499	1701499	1701499
3	--	--	--	--	--	--	--	--	--
4	--	--	--	--	--	--	--	--	--
5	1701509	1701509	1701509	1701509	1701509	1701509	1701509	1701509	1701509
6	1701529	1701529	1701529	1701529	1701529	1701529	1701529	1701529	1701529
7	--	--	--	--	--	--	--	--	--
8	--	--	--	--	--	--	--	--	--
9	--	--	--	--	--	--	--	--	--
10	1703811	1703811	1703811	1703811	1703811	1703811	1703811	1703811	1703811
11	1703814	1703814	1703814	1703814	1703814	1703814	1703814	1703814	1703814
12	1704277	1704277	1704277	1704277	1704277	1704277	1704277	1704277	1704277
13	1704412	1704412	1704412	1704412	1704412	1704412	1704412	1704412	1704412
14	--	--	--	--	--	--	1705084	1705084	1705084
15	--	--	--	--	--	--	1705514	1705514	1705514
16	--	--	--	--	--	--	--	--	--
17	3251243	3251243	3251243	3251243	--	3251243	--	--	--

SECTION 4 - MACHINE OPERATION

Table 4-4. 600AJ Decal Legend - S/N 0300140401 to Present

Item #	ANSI 0273892-10	Canadian French 0273894-9	CE 0273896-5	Spanish 0273900-10	Portuguese 0273902-9	Japanese 0273904-11	Australian 1001114389-1	Chinese Simplified 1001116842-3	Chinese Traditional 1001116843-3
18	--	--	--	--	--	--	--	--	--
19	--	--	--	--	--	--	--	--	1001117034
20	--	--	--	--	--	--	--	--	1001117035
21	--	1704006	--	1704007	1705901	--	--	--	--
22	1703953	1703942	--	1703941	1705903	1703944	--	1001116845	1703943
23	--	--	--	--	--	--	--	--	--
24	1702868	1704000	--	1704001	1705967	--	--	1706968	1001116846
25	1703797	1703924	1705921	1703923	1705895	1703926	1705921	1001116847	1703925
26	1705336	1705347	1705822	1705917	1705896	1705344	1705822	1001116848	1001116849
27	1703804	1703948	1701518	1703947	1705898	1703950	1701518	1001116850	1703949
28	1703805	1703936	1705961	1703935	1705897	1703938	1705961	1703937	1001116851
29	--	1703984	1705828	1703983	1705902	1703980	1705828	1001116852	1703982
30	3251813	3251813	--	3251813	3251813	3251813	--	3251813	3251813
31	--	--	--	--	--	--	--	--	--
32	--	--	--	--	--	--	--	--	--
33	1703469	1703469	1703469	1703469	1703469	1703469	1703469	1703469	1703469
34	1702631	1702631	1702631	1702631	1702631	1702631	1702631	1702631	1702631
35	1702819	1702819	1702819	1702819	1702819	1702819	1702819	1702818	1702818

SECTION 4 - MACHINE OPERATION

Table 4-4. 600AJ Decal Legend - S/N 0300140401 to Present

Item #	ANSI 0273892-10	Canadian French 0273894-9	CE 0273896-5	Spanish 0273900-10	Portuguese 0273902-9	Japanese 0273904-11	Australian 1001114389-1	Chinese Simplified 1001116842-3	Chinese Traditional 1001116843-3
36	1001121814	1001121816	1705978	1001121818	1001121655	1001121821	1705978	1001121825	1001121823
37	1001121801	1001121803	1705978	1001121805	1001121656	1001121808	1705978	1001121812	1001121810
38	--	--	--	--	--	--	--	--	--
39	1704885	1704885	1704885	1704885	1704885	1704885	1704885	1704885	1704885
40	1706948	1706948	--	1706948	1706948	1706948	--	--	--
41	--	--	--	--	--	--	--	--	--
42	--	--	--	--	--	--	--	--	--
43	--	--	--	--	--	--	--	--	--
44	--	--	--	--	--	--	--	--	--
45	--	--	--	--	--	--	--	--	--
46	--	--	--	--	--	--	--	--	--
47	--	--	--	--	--	--	--	--	--
48	--	--	--	--	--	--	--	--	--
49	--	--	--	--	--	--	--	--	--
50	--	--	--	--	--	--	--	--	--
51	--	--	--	--	--	--	--	--	--
52	--	--	--	--	--	--	--	--	--
53	--	--	--	--	--	--	--	--	--

SECTION 4 - MACHINE OPERATION

Table 4-4. 600AJ Decal Legend - S/N 0300140401 to Present

Item #	ANSI 0273892-10	Canadian French 0273894-9	CE 0273896-5	Spanish 0273900-10	Portuguese 0273902-9	Japanese 0273904-11	Australian 1001114389-1	Chinese Simplified 1001116842-3	Chinese Traditional 1001116843-3
54	--	--	--	--	--	--	--	--	--
55	--	--	--	--	--	--	--	--	--
56	--	--	--	--	--	--	--	--	--
57	--	--	--	--	--	--	--	--	--
58	--	--	--	--	--	--	--	--	--
59	--	--	--	--	--	--	--	--	--
60	--	--	--	--	--	--	--	--	--
61	--	--	--	--	--	--	--	--	--
62	1700584	1700584	1700584	1702573	1700584	1700584	1700584	1700584	1700584
63	1001108493	1001108493	--	1001108493	1001108493	1001108493	--	1001108493	1001108493
64	1706941	1706941	--	1706941	1706941	1706941	--	1706941	1706941
65	1703687	1703687	1703687	1703687	1703687	1703687	1703687	1703687	1703687
66	1702265	1703990	1705977	1702617	1703544	1702271	1705977	1001116861	1001116862
67	1705351	1705429	--	1705910	1705905	1705426	--	1705430	1001116863
68	--	--	--	--	--	--	1001112551	--	--

SECTION 5. EMERGENCY PROCEDURES

5.1 GENERAL

This section explains the steps to be taken in case of an emergency situation while operating.

5.2 INCIDENT NOTIFICATION

JLG Industries, Inc. must be notified immediately of any incident involving a JLG product. Even if no injury or property damage is evident, the factory should be contacted by telephone and provided with all necessary details.

In USA:

JLG Phone: 877-JLG-SAFE (554-7233)
(8am till 4:45pm EST)

Outside USA:

240-420-2661

E-mail:

ProductSafety@JLG.com

Failure to notify the manufacturer of an incident involving a JLG Industries product within 48 hours of such an occurrence may void any warranty consideration on that particular machine.

NOTICE

FOLLOWING ANY ACCIDENT, THOROUGHLY INSPECT THE MACHINE AND TEST ALL FUNCTIONS FIRST FROM THE GROUND CONTROLS, THEN FROM THE PLATFORM CONTROLS. DO NOT LIFT ABOVE 10 FT. (3 M) UNTIL YOU ARE SURE THAT ALL DAMAGE HAS BEEN REPAIRED, IF REQUIRED, AND THAT ALL CONTROLS ARE OPERATING CORRECTLY.

5.3 EMERGENCY OPERATION

Operator Unable to Control Machine

IF THE PLATFORM OPERATOR IS PINNED, TRAPPED OR UNABLE TO OPERATE OR CONTROL MACHINE:

1. Other personnel should operate the machine from ground controls only as required.
2. Other qualified personnel on the platform may use the platform controls. DO NOT CONTINUE OPERATION IF CONTROLS DO NOT FUNCTION PROPERLY.

SECTION 5 - EMERGENCY PROCEDURES

3. Cranes, forklift trucks or other equipment can be used to remove platform occupants and stabilize motion of the machine.

Platform or Boom Caught Overhead

If the platform or boom becomes jammed or snagged in overhead structures or equipment, rescue platform occupants prior to freeing the machine.

5.4 EMERGENCY TOWING PROCEDURES

Towing this machine is prohibited, unless properly equipped. However, provisions for moving the machine have been incorporated. For specific procedures, refer to Section 4.

5.5 MANUAL DESCENT (MACHINES PRIOR TO S/N 70975)

The manual descent valves are used, in the event of total power failure, to retract and lower the boom using gravity. The manual descent valves are located on the right side of the turntable (in tank compartment). Look for the instruction decal located on the right side of turntable below control valve. The procedure is as follows:

1. To retract the lower boom telescope function: turn knob #1 and knob #4 clockwise until tight. Pump the hand pump until tight. When this operation has been completed, turn #1 and #4 counterclockwise 3 turns.
2. To retract the lower boom, turn knob #1, #2 and #4 clockwise until tight. Turn knob #3 counterclockwise 3 turns. Locate a knurled head screw, attached to a wire cable on the right side of the main valve bank assembly. Thread this into the end of the coil assembly that it is attached to. Pump the hand pump until the lower boom is completely lowered. When this operation is complete, remove the knurled head screw from the end of the valve coil. (THE KNURLED HEAD SCREW "MUST" BE REMOVED FROM THE END OF THE VALVE BEFORE NORMAL OPERATION OF THE MACHINE CAN RESUME.)

When this operation has been completed, turn #1, #2, and #4 counterclockwise 3 turns. Turn #3 clockwise until tight.
3. To lower the upper boom: (THE LOWER BOOM MUST BE COMPLETELY LOWERED BEFORE STARTING THIS OPERATION IN ORDER TO MAINTAIN STABILITY OF THE MACHINE.) Turn knob #1 and #2 clockwise until tight. Pump the hand pump until tight. When this operation has been completed, turn #1 and #2 counterclockwise 3 turns.
4. When the manual descent operation has been completed, knob #1, #2, and #4 should be open (counterclockwise) 3 turns. Knob #3 should be closed (clockwise).

SECTION 6. GENERAL SPECIFICATIONS & OPERATOR MAINTENANCE

6.1 INTRODUCTION

This section of the manual provides additional necessary information to the operator for proper operation and maintenance of this machine.

The maintenance portion of this section is intended as information to assist the machine operator to perform daily maintenance tasks only, and does not replace the more thorough Preventive Maintenance and Inspection Schedule included in the Service and Maintenance Manual.

Other Publications Available:

Service and Maintenance Manual - ANSI Spec (Prior to s/n 0300080000)	3120718
Service and Maintenance Manual (Euro Spec) (Prior to s/n 0300080000)	3120841
Service and Maintenance Manual - Global Spec (s/n 0300080000 to Present).....	3121201
Illustrated Parts Manual - ANSI Spec (Prior to s/n 0300068000)	3120719
Illustrated Parts Manual - Euro Spec (Prior to s/n 0300068000)	3120841
Illustrated Parts Manual - ANSI Spec (s/n 0300068000 to s/n 0300087000)	3121177
Illustrated Parts Manual - Euro Spec (s/n 0300068000 to s/n 0300087000)	3121855
Illustrated Parts Manual - Global Spec (s/n 0300087000 to Present).....	3121206

SECTION 6 - GENERAL SPECIFICATIONS & OPERATOR MAINTENANCE

6.2 OPERATING SPECIFICATIONS

Table 6-1. Operating Specifications - Prior to S/N 0300140401

Maximum Work Load (Capacity)	
Unrestricted:	500 lb (230 kg)
Restricted:	1000 lb (450 kg)
Maximum Travel Grade (Gradeability)	
2WD	30%
4WD	45%
Maximum Travel Grade (Side Slope)	5°
Turning Radius - (outside)	
2WS	17 ft. 8 in. (5.38 m)
4WS	11 ft. 8 in. (3.56 m)
Turning Radius - (outside) narrow chassis	
2WS	16 ft. 6 in. (5.03 m)
4WS	11 ft. 2 in. (3.4 m)
Turning Radius - (inside)	
2WS	11 ft. 5 in. (3.48 m)
4WS	5 ft. 6 in. (1.68 m)
Turning Radius - (inside) narrow chassis	
2WS	12 ft. 2 in. (3.71 m)
4WS	5 ft. 7 in. (1.7 m)
Maximum Tire Load:	11,500 lbs. (5227 kg)

Table 6-1. Operating Specifications - Prior to S/N 0300140401

Ground Bearing Pressure	
600A	77 psi (5.4 kg/cm ²)
600AJ	75 psi (5.3 kg/cm ²)
600A - narrow chassis	94 psi (6.6 kg/cm ²)
600AJ - narrow chassis	94 psi (6.6 kg/cm ²)
Maximum Drive Speed - A Models	
2WD	3.6 MPH (5.80 Km/hr.)
4WD	4 MPH (6.44 Km/hr.)
Gross Machine Weight (Approximate)	
600A	21,500 lbs. (9,752 kg)
600AJ	22,200 lbs. (10,025 kg)
600A - narrow chassis	23,900 lbs. (10,841 kg)
600AJ - narrow chassis	24,000 lbs. (10,886 kg)

SECTION 6 - GENERAL SPECIFICATIONS & OPERATOR MAINTENANCE

Table 6-2. Operating Specifications - S/N 0300140401 to Present

Maximum Work Load (Capacity) - ANSI	
Unrestricted:	500 lb (227 kg)
Restricted:	1000 lb (454 kg)
Maximum Work Load (Capacity) - CE & Australia	
Unrestricted:	500 lb (230 kg)
Restricted:	1000 lb (450 kg)
Maximum Travel Grade (Gradeability)	
2WD	30%
4WD	45%
Maximum Travel Grade (Side Slope)	5°
Turning Radius - (outside)	
2WS	17 ft. 8 in. (5.38 m)
4WS	11 ft. 8 in. (3.56 m)
Turning Radius - (outside) narrow chassis	
2WS	16 ft. 6 in. (5.03 m)
4WS	11 ft. 2 in. (3.4 m)
Turning Radius - (inside)	
2WS	11 ft. 5 in. (3.48 m)
4WS	5 ft. 6 in. (1.68 m)
Turning Radius - (inside) narrow chassis	
2WS	12 ft. 2 in. (3.71 m)
4WS	5 ft. 7 in. (1.7 m)

Table 6-2. Operating Specifications - S/N 0300140401 to Present

Maximum Tire Load:	11,500 lbs. (5216 kg)
Ground Bearing Pressure	
600A	77 psi (5.4 kg/cm ²)
600AJ	75 psi (5.3 kg/cm ²)
600A - narrow chassis	94 psi (6.6 kg/cm ²)
600AJ - narrow chassis	94 psi (6.6 kg/cm ²)
Maximum Drive Speed - A Models	
2WD	3.6 MPH (5.80 Km/hr.)
4WD	4 MPH (6.44 Km/hr.)
Gross Machine Weight (Approximate)	
600A	21,500 lbs. (9,752 kg)
600AJ	22,200 lbs. (10,025 kg)
600A - narrow chassis	23,900 lbs. (10,841 kg)
600AJ - narrow chassis	24,000 lbs. (10,886 kg)

SECTION 6 - GENERAL SPECIFICATIONS & OPERATOR MAINTENANCE

Capacities

Table 6-3. Capacities

Fuel Tank	30 U.S. Gallons (113.6 L)
Hydraulic Oil Tank	30.6 Gallons (115.8 L) with 10% air space
Hydraulic System (Including Tank)	36.72 Gallons (139 L)
Torque Hub, Drive*	17 ounces (0.50 L)
Engine Crankcase Ford LRG-425 Gas w/Filter Ford LRG-423 Gas w/Filter Deutz F4M1011F Diesel w/Filter Deutz F4M2011F Diesel w/Filter Deutz D2011L04 Continental TMD27 Diesel w/Filter Caterpillar 3044C Diesel w/Filter GM	4.5 quarts (4.25L) 5.0 quarts (4.73L) 11 quarts (10.5L) 11 quarts (10.5L) 11 quarts (10.5L) 7.0 quarts (6.65 L) 10.6 quarts (10L) 4.5 qts. (4.25 L) w/Filter
Cooling System	16 Quarts (15.14 L.)
*Torque hubs should be one half full of lubricant.	

Engine Data

Table 6-4. Continental TMD27 Specifications

Fuel	Diesel
Oil Capacity w/Filter w/o Filter	7.00 Quarts (6.65 l) 6.00 Quarts (5.7 l)
Low RPM	1800
High RPM	2800
Alternator	63 Amps, Belt Drive
Battery	85 Amphour, 550 Cold Cranking Amps, 12 VDC
Fuel Consumption Low RPM High RPM	1.80 GPH (6.81 lph) 2.30 GPH (8.71 lph)
Horsepower	66.5 @ 3000 RPM
Coolant	3.8 Gallons (3.6 l)

SECTION 6 - GENERAL SPECIFICATIONS & OPERATOR MAINTENANCE

Table 6-5. Ford LRG-423 Specifications

Fuel	Gasoline
Crankcase Capacity w/Filter w/o Filter	5.00 Quarts (4.73 L) 4.00 Quarts (3.79 L)
Idle RPM	1000
Low RPM	1800
High RPM	2800
Alternator	40 Amp, Belt Drive
Battery	85 Ampour, 550 Cold Cranking Amps, 12 VDC
Fuel Consumption Low RPM High RPM	3.45 GPH (13.06 lph) 4.60 GPH (17.41 lph)
Horsepower	54 @ 2400 RPM, full load
Cooling System	16 Quarts (15.14 L.)
Spark Plug	AWSF-52-C
Spark Plug Gap	0.044 in. (1.117 mm)

Table 6-6. Ford LRG-425 Specifications

Fuel	Gasoline
Crankcase Capacity	4.5 Quarts (4.25 L) w/Filter
Idle RPM	1000
Low RPM	1800
High RPM	2800
Alternator	40 Amp, Belt Drive
Battery	85 Ampour, 550 Cold Cranking Amps, 12 VDC
Fuel Consumption Low RPM High RPM	3.45 GPH (13.06 lph) 4.60 GPH (17.41 lph)
Horsepower	54 @ 2400 RPM, full load
Cooling System	16 Quarts (15.14 L.)
Spark Plug	AWSF-52-C
Spark Plug Gap	0.044 in. (1.117 mm)

SECTION 6 - GENERAL SPECIFICATIONS & OPERATOR MAINTENANCE

Table 6-7. Deutz F4M1011F/F4M2011 Specifications

Fuel	Diesel
Oil Capacity	
Cooling System	5 Quarts (4.5 L)
Crankcase w/Filter	11 Quarts (10.5 L)
Total Capacity	16 Quarts (15 L)
Idle RPM	1000
Low RPM	1800
High RPM	2800
Alternator	60 Amp, belt drive
Battery	950 Cold Cranking Amps, 205 Minutes Reserve Capacity, 12 VDC
Fuel Consumption	
Low RPM	1.90 GPH (7.19 lph)
High RPM	2.50 GPH (9.46 lph)
Horsepower	65

Table 6-8. Deutz D2011L04 Specifications

Fuel	Diesel
Oil Capacity	
Cooling System	5 Quarts (4.5 L)
Crankcase	11 Quarts (10.5 L) w/Filter
Total Capacity	16 Quarts (15 L)
Idle RPM	1000
Low RPM	1800
High RPM	2500
Alternator	60 Amp, belt drive
Battery	950 Cold Cranking Amps, 205 Minutes Reserve Capacity, 12 VDC
Fuel Consumption	
Low RPM	1.90 GPH (7.19 lph)
High RPM	2.50 GPH (9.46 lph)
Horsepower	49

SECTION 6 - GENERAL SPECIFICATIONS & OPERATOR MAINTENANCE

Table 6-9. Caterpillar 3044C / 3.4

Type	Four Stroke Cycle
Cylinders	4 in-line
Bore	3.70 inch (94 mm)
Stroke	4.72 inch (120 mm)
Aspiration	turbocharged
Compression ratio	19:1
Displacement	203 in ³ (3.33 L)
Firing Order	1-3-4-2
Rotation (viewed from flywheel)	Counterclockwise
Oil Capacity (w/filter)	10.6 quarts (10 L)
Cooling System (Engine Only)	5.8 quarts (5.5 L)
Idle RPM	1000
Low RPM	1800
High RPM - 3044C	2600
High RPM - 3.4	2500
Alternator	60 Amp, belt drive
Battery	930 Cold Cranking Amps, 205 Minutes Reserve Capacity, 12 VDC

Table 6-10. GM 3.0L

Fuel	Gasoline or Gasoline/LP Gas
No. of Cylinders	4
BHP Gasoline LP	83 hp @ 3000 rpm 75 hp @ 3000 rpm
Bore	4.0 in. (101.6 mm)
Stroke	3.6 in. (91.44 mm)
Displacement	181 cu.in. (3.0 L, 2966 cc)
Oil Capacity w/filter	4.5 qts. (4.25 L)
Minimum Oil Pressure at idle Hot	6 psi (0.4 Bar) @ 1000 rpm 18 psi (1.2 Bar) @ 2000 rpm
Compression Ratio	9.2:1
Firing Order	1-3-4-2
Max. RPM	2800

SECTION 6 - GENERAL SPECIFICATIONS & OPERATOR MAINTENANCE

Tires

Table 6-11. Tire Specifications

Size	14 x 17.5	14 x 17.5	14 x 17.5
Load Range	G	G	*
Ply Rating	14	14	N/A
Tire Pressure	90 PSI (6 Bar)	Foam-Filled	Air-Boss

* Load Capacity - 11,800 lb. (5353 kg) - Static

Dimensional Data

Table 6-12. Dimensional Data

Machine Height (Stowed)	8 ft. 3.75 in. (2.53 m)
Machine Length (Stowed) 600A Over Drive Axle 600AJ Over Drive Axle	26 ft. 5 in. (8.05 m) 28 ft. 11.4375 in. (8.82 m)
Machine Width Standard Narrow Chassis	8 ft. (2.44 m) 7 ft. (2.13 m)
Wheelbase	8 ft. 0 in. (2.44 m)
Boom Elevation - 600A	+60 ft. 5 3/8 in. (18.42 m) -11 in. (0.28 m)
Boom Elevation - 600AJ	+60 ft. 6 3/4 in. (18.46 m) -2 ft. 8 13/16 in. (0.83 m)

Torque Requirements

Table 6-13. Torque Requirements

Description	Torque Value (Dry)	Interval Hours
Bearing To Chassis	See Note	50/600*
Bearing To Turntable	See Note	50/600*
Wire Rope	15 ft. lbs (20 Nm)	150
Wheel Lugs	See Section 6.4	150
Engine Mounting Bolts	165 ft. lbs. (231 Nm)	A/R
Engine Manifold Mounting Bolts	30 ft. lbs. (42 Nm)	A/R
*Check swing bearing bolts for security after first 50 hours of operation and every 600 hours thereafter. (See Swing Bearing in Section 3.)		

Hydraulic Oil

Table 6-14. Hydraulic Oil Specifications

HYDRAULIC SYSTEM OPERATING TEMPERATURE RANGE	SAE VISCOSITY GRADE
+0° to +180° F (-18° C to +83° C)	10W
+0° F to +210° F (-18° C to +99° C)	10W-20, 10W-30
+50° F to +210° F (+10° C to +210° C)	20W-20

NOTE: Hydraulic oils must have anti-wear qualities at least to API Service Classification GL-3, and sufficient chemical stability for mobile hydraulic system service. JLG Industries recommends Mobilfluid 424 hydraulic oil, which has an SAE viscosity index of 152.

NOTE: When temperatures remain below 20° F (-7° C), JLG Industries recommends the use of Mobil DTE 13M.

SECTION 6 - GENERAL SPECIFICATIONS & OPERATOR MAINTENANCE

Aside from JLG recommendations, it is not advisable to mix oils of different brands or types, as they may not contain the same required additives or be of comparable viscosities. If use of hydraulic oil other than Mobilfluid 424 is desired, contact JLG Industries for proper recommendations.

Table 6-15. Mobilfluid 424 Specs

SAE Grade	10W30
Gravity, API	29.0
Density, Lb/Gal. 60°F	7.35
Pour Point, Max	-46°F (-43°C)
Flash Point, Min.	442°F (228°C)
Viscosity	
Brookfield, cP at -18°C	2700
at 40° C	55 cSt
at 100° C	9.3 cSt
Viscosity Index	152

Table 6-16. Mobil DTE 13M Specs

ISO Viscosity Grade	#32
Specific Gravity	0.877
Pour Point, Max	-40°F (-40°C)
Flash Point, Min.	330°F (166°C)
Viscosity	
at 40° C	33cSt
at 100° C	6.6 cSt
at 100° F	169 SUS
at 210° F	48 SUS
cp at -20° F	6,200
Viscosity Index	140

SECTION 6 - GENERAL SPECIFICATIONS & OPERATOR MAINTENANCE

Table 6-17. Exxon Unavis HVI 26 Specs

Specific Gravity	32.1
Pour Point	-76°F (-60°C)
Flash Point	217°F (103°C)
Viscosity	
at 40° C	25.8 cSt
at 100° C	9.3 cSt
Viscosity Index	376
NOTE: <i>Mobil/Exxon recommends that this oil be checked on a yearly basis for viscosity.</i>	

Table 6-18. Quintolubric 888-46

Density	0.91 @ 15°C (59°F)
Pour Point	< -20°C (< -4°F)
Flash Point	275°C (527°F)
Fire Point	325°C (617°F)
Autoignition Temperature	450°C (842°F)
Viscosity	
at 0° C (32°F)	360 cSt
at 20° C (68°F)	102 cSt
at 40° C (104°F)	46 cSt
at 100° C (212°F)	10 cSt
Viscosity Index	220

Critical Stability Weights

⚠ WARNING

DO NOT REPLACE ITEMS CRITICAL TO STABILITY WITH ITEMS OF DIFFERENT WEIGHT OR SPECIFICATION (FOR EXAMPLE: BATTERIES, FILLED TIRES, COUNTERWEIGHT, ENGINE & PLATFORM) DO NOT MODIFY UNIT IN ANY WAY TO AFFECT STABILITY.

Table 6-19. Critical Stability Weights

		600AJ		600A	
		LB.	KG.	LB.	KG.
Tire and Wheel (Ballasted Only)	Size (14-17.5)	165	75	165	75
Engine	Ford	460	209	460	209
	Deutz	534	242	534	242
	Continental	558	253	558	253
Counterweight	Weight	6200	2812	5700	2586
Platform	6 ft. (1.83 M)	205	93	205	93
	8 ft. (2.44 M)	230	105	230	105

Serial Number Locations

A serial number plate is affixed to the left rear side of the frame. If the serial number plate is damaged or missing, the machine serial number is stamped on the left side of the frame.

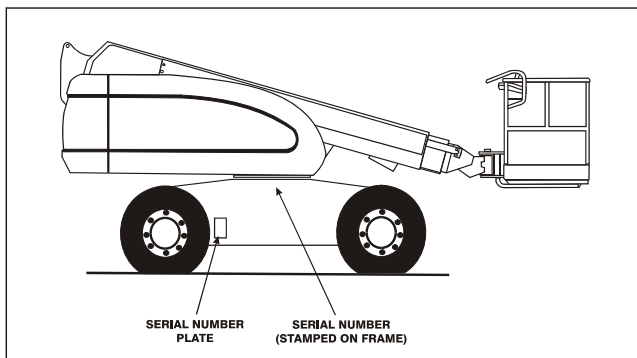

Figure 6-1. Serial Number Locations

This page left blank intentionally.

SECTION 6 - GENERAL SPECIFICATIONS & OPERATOR MAINTENANCE

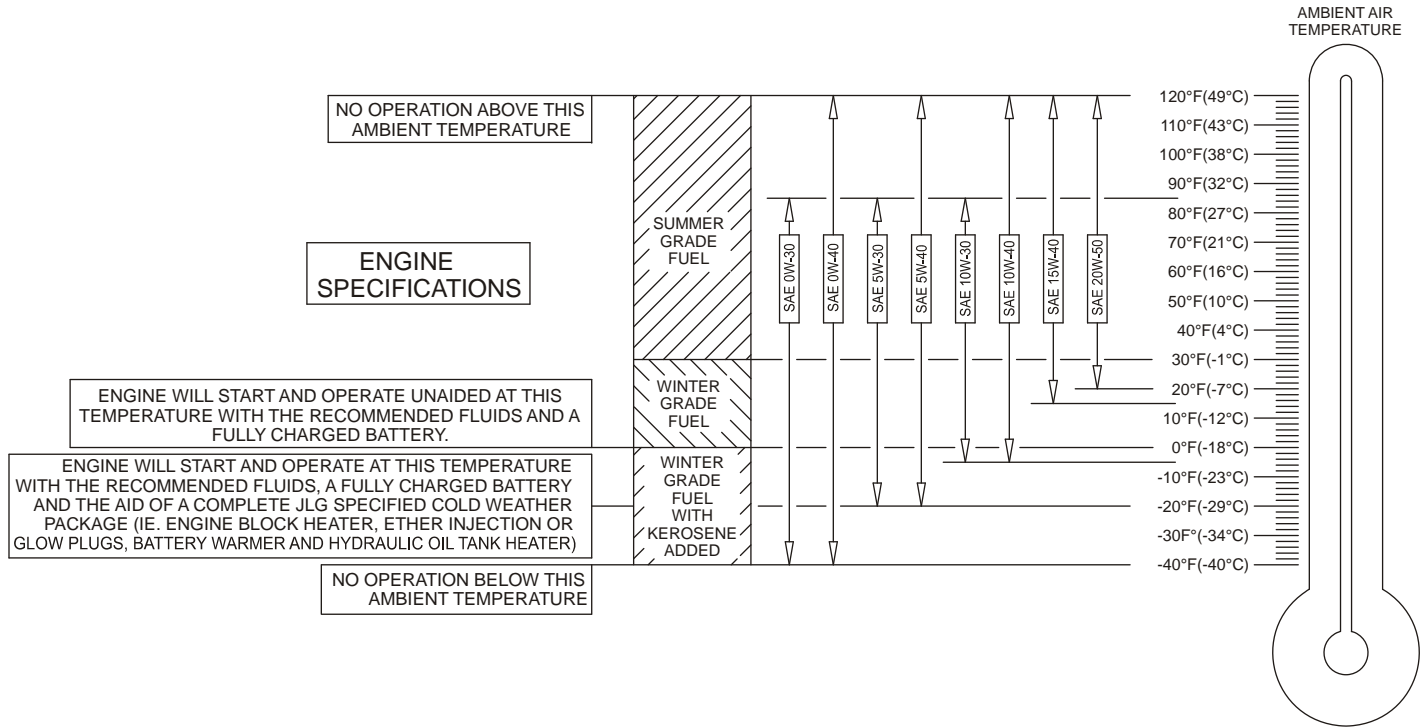

Figure 6-2. Engine Operating Temperature Specifications - Deutz - Sheet 1 of 2

SECTION 6 - GENERAL SPECIFICATIONS & OPERATOR MAINTENANCE

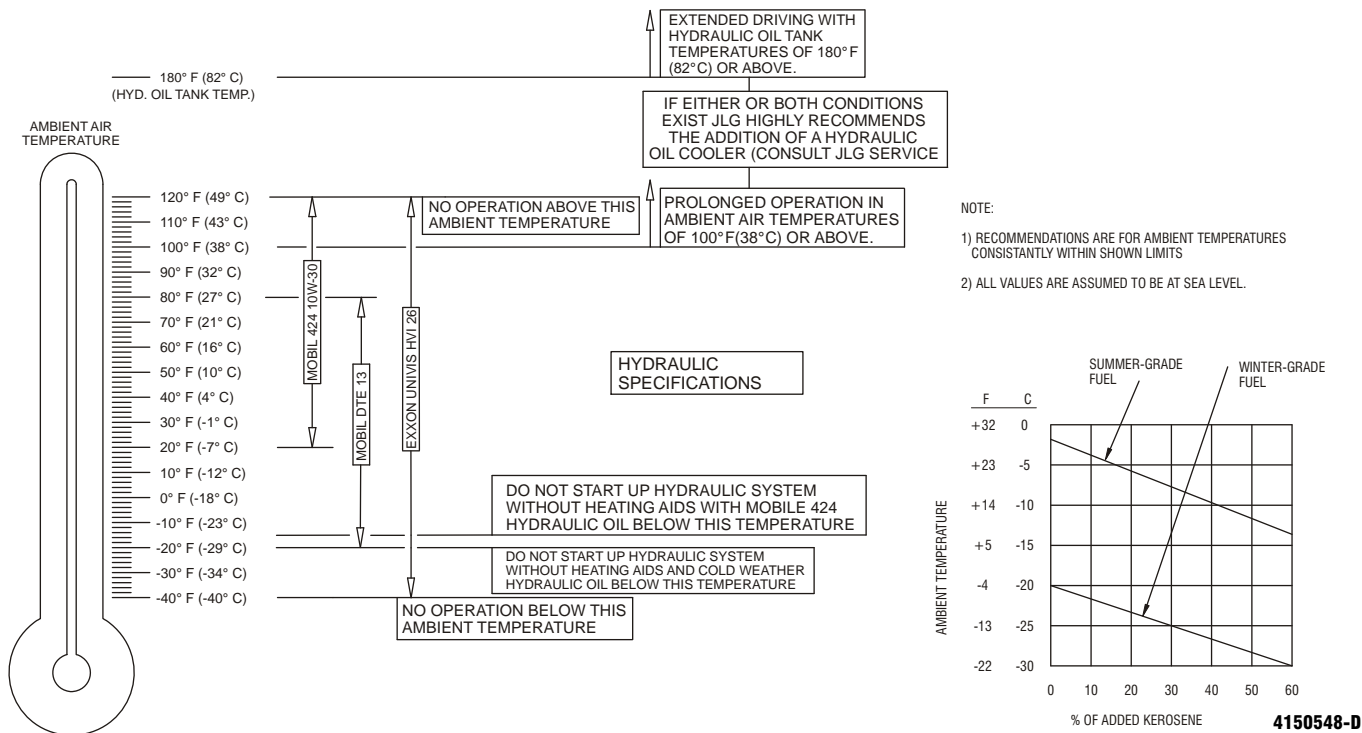

Figure 6-3. Engine Operating Temperature Specifications - Deutz - Sheet 2 of 2

SECTION 6 - GENERAL SPECIFICATIONS & OPERATOR MAINTENANCE

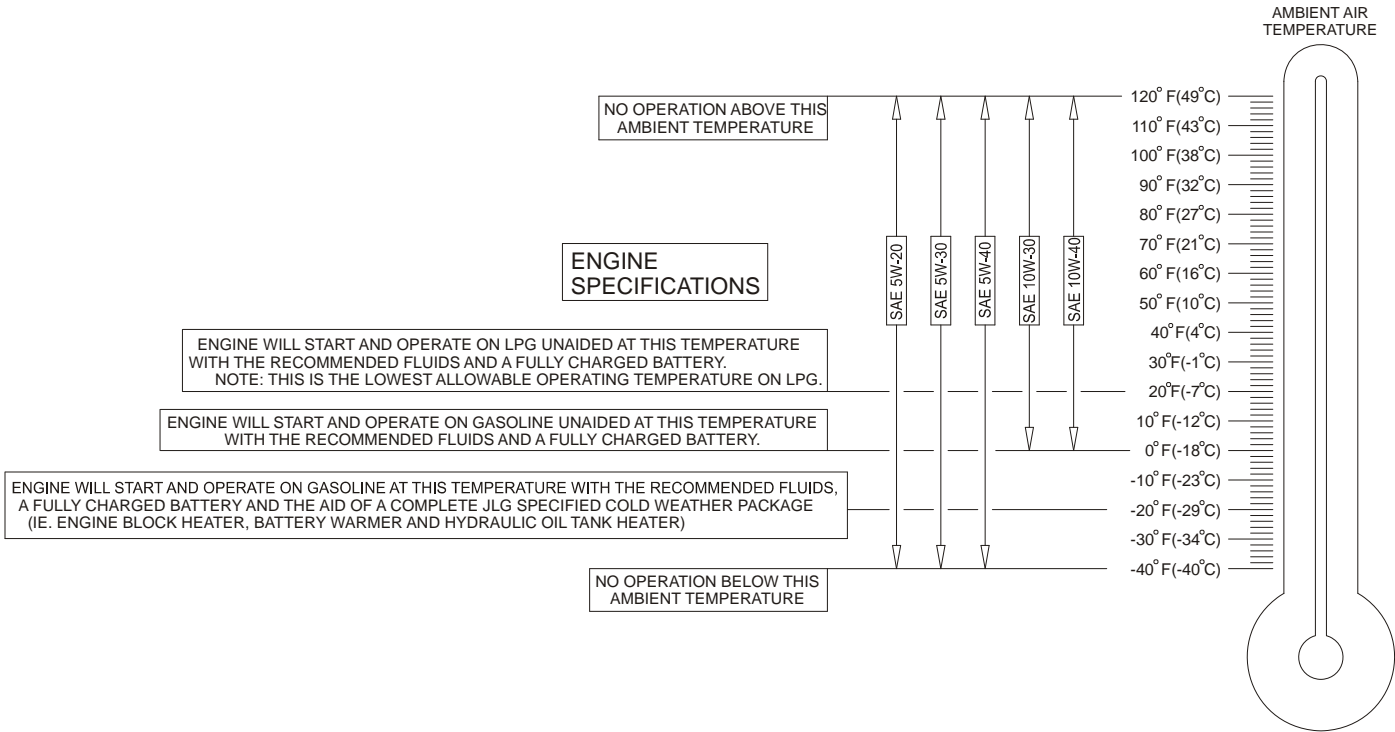
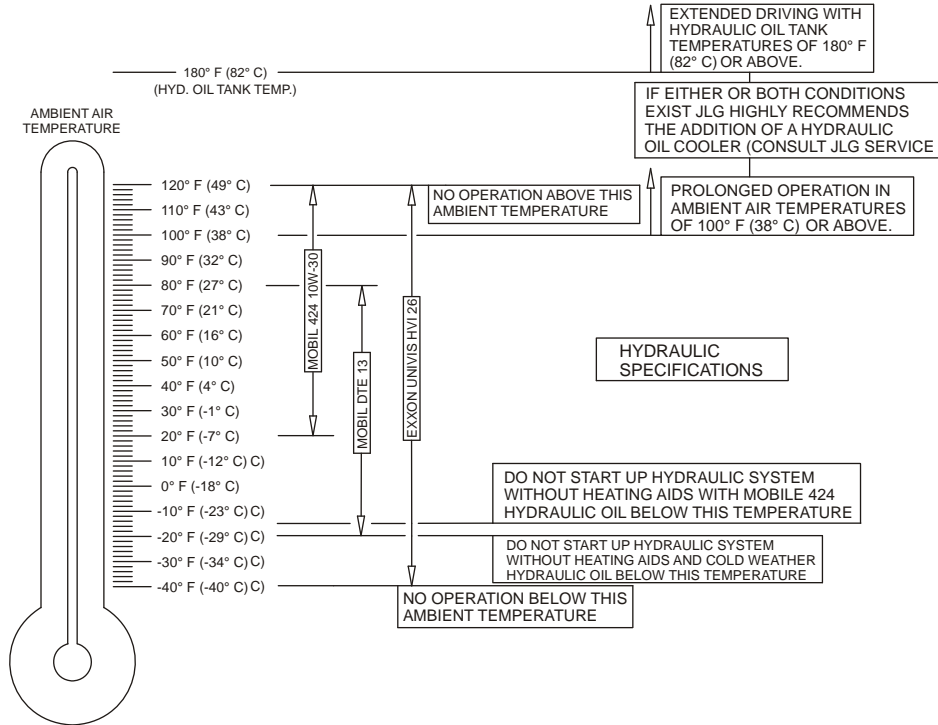

Figure 6-4. Engine Operating Temperature Specifications - Ford - Sheet 1 of 2

SECTION 6 - GENERAL SPECIFICATIONS & OPERATOR MAINTENANCE



NOTE:

- 1) RECOMMENDATIONS ARE FOR AMBIENT TEMPERATURES CONSISTANTLY WITHIN SHOWN LIMITS
- 2) ALL VALUES ARE ASSUMED TO BE AT SEA LEVEL.

Figure 6-5. Engine Operating Temperature Specifications - Ford - Sheet 2 of 2

4150548-D

SECTION 6 - GENERAL SPECIFICATIONS & OPERATOR MAINTENANCE

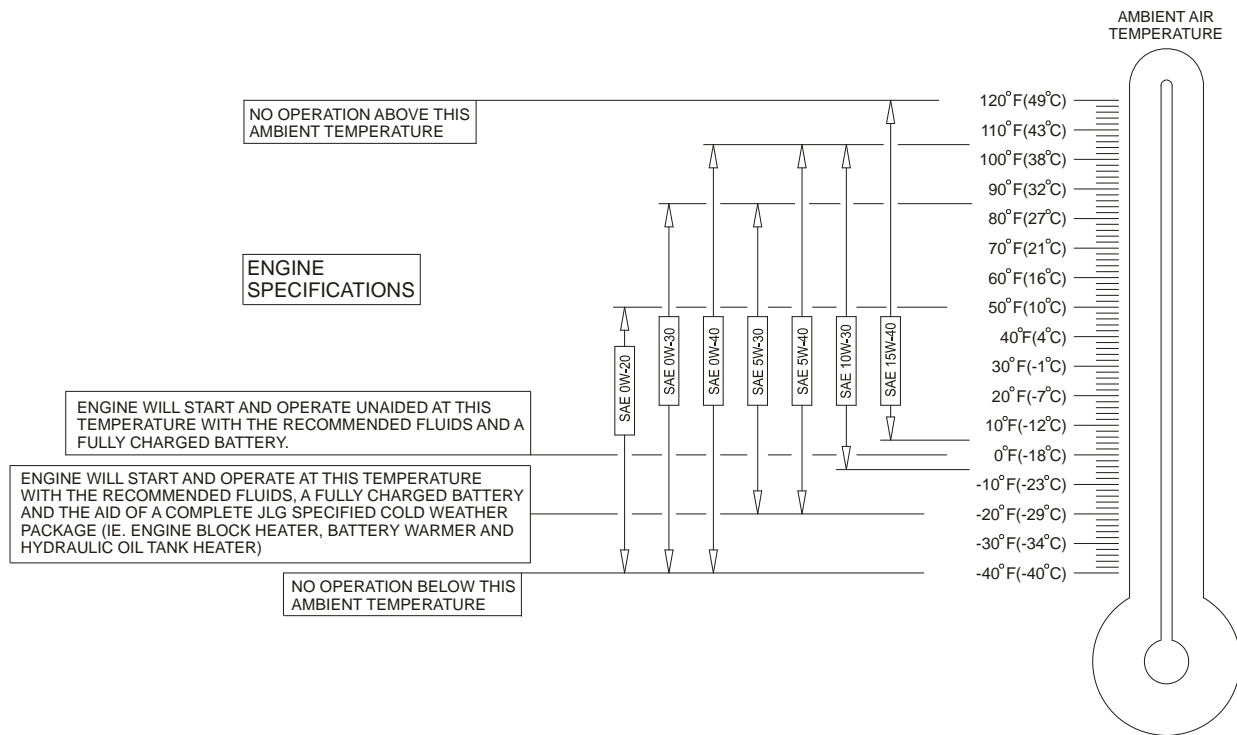
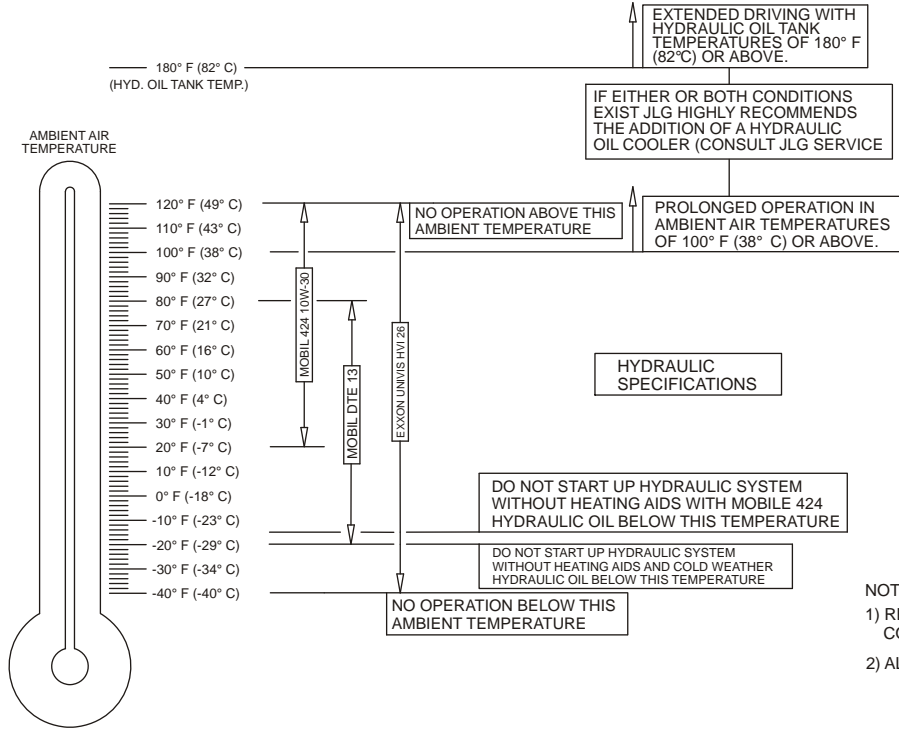

Figure 6-6. Engine Operating Temperature Specifications - Caterpillar - Sheet 1 of 2

SECTION 6 - GENERAL SPECIFICATIONS & OPERATOR MAINTENANCE



NOTE:
 1) RECOMMENDATIONS ARE FOR AMBIENT TEMPERATURES CONSISTENTLY WITHIN SHOWN LIMITS
 2) ALL VALUES ARE ASSUMED TO BE AT SEA LEVEL.

Figure 6-7. Engine Operating Temperature Specifications - Caterpillar - Sheet 2 of 2

4150548-D

SECTION 6 - GENERAL SPECIFICATIONS & OPERATOR MAINTENANCE

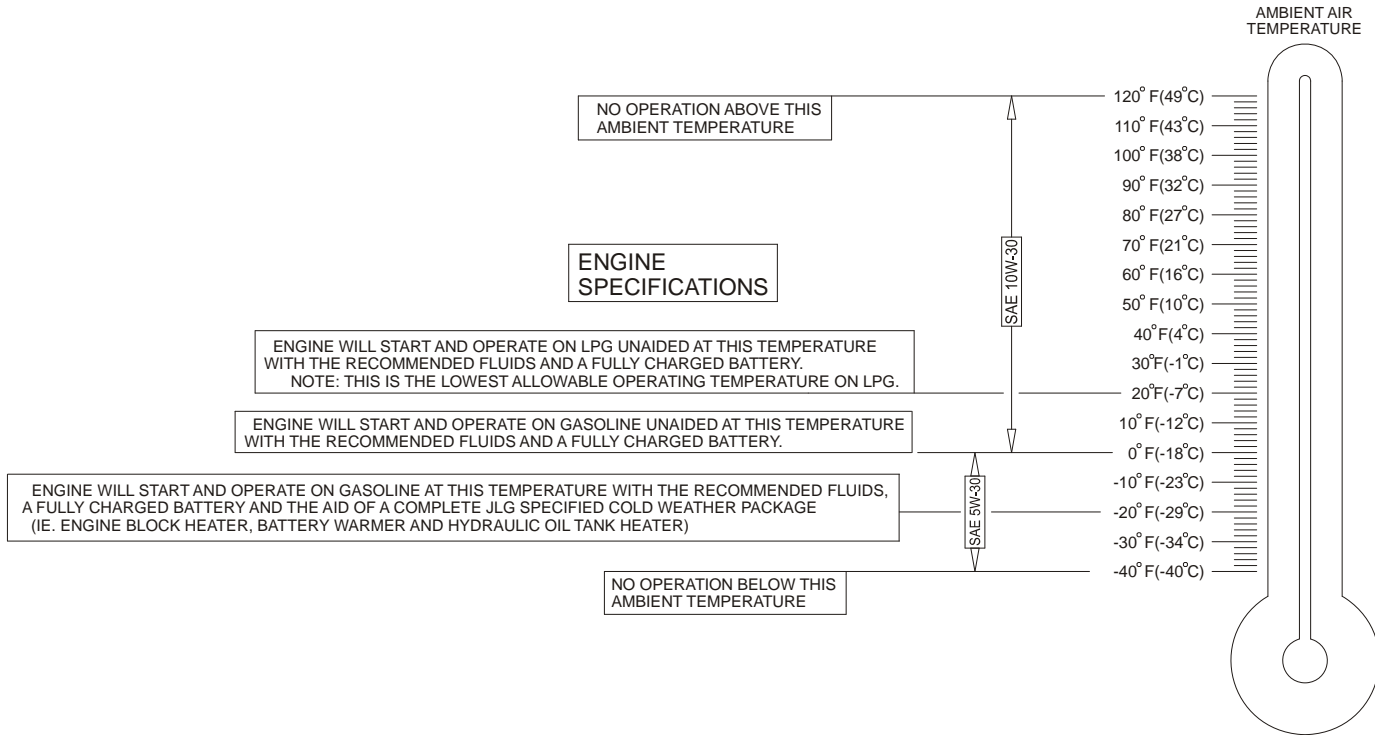
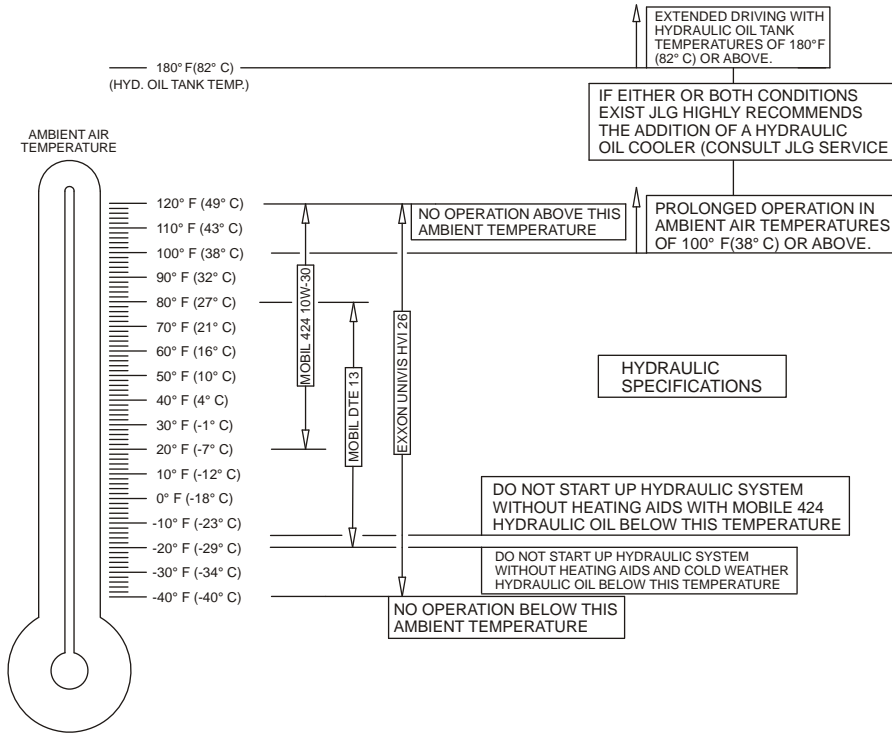

Figure 6-8. Engine Operating Temperature Specifications - GM - Sheet 1 of 2

SECTION 6 - GENERAL SPECIFICATIONS & OPERATOR MAINTENANCE



NOTE:

- 1) RECOMMENDATIONS ARE FOR AMBIENT TEMPERATURES CONSISTENTLY WITHIN SHOWN LIMITS
- 2) ALL VALUES ARE ASSUMED TO BE AT SEA LEVEL.

Figure 6-9. Engine Operating Temperature Specifications - GM - Sheet 2 of 2

4150548-D

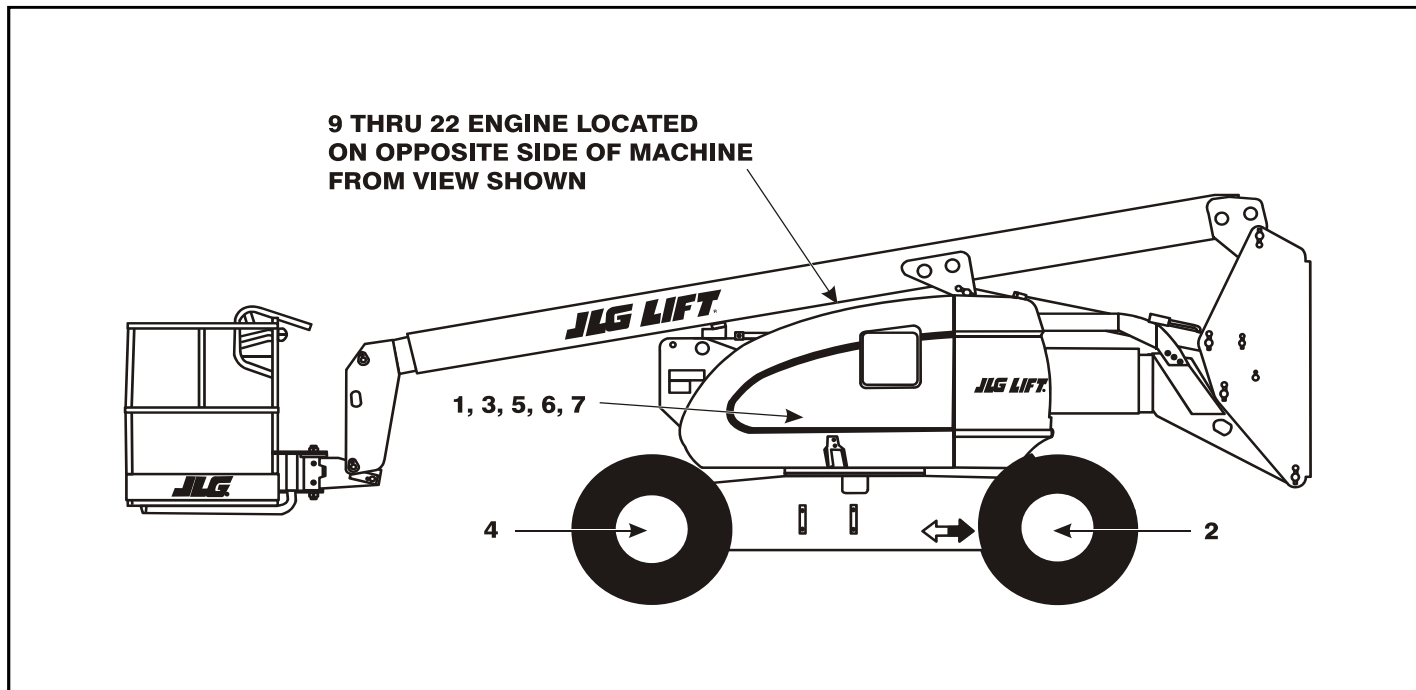

Figure 6-10. Lubrication and Maintenance Point Location

6.3 OPERATOR MAINTENANCE

NOTE: The following numbers correspond to those in Figure 6-10., Lubrication and Maintenance Point Location.

Table 6-20. Lubrication Specifications

KEY	SPECIFICATIONS
MPG	Multipurpose Grease having a minimum dripping point of 350° F (177° C). Excellent water resistance and adhesive qualities, and being of extreme pressure type. (Timken OK 40 pounds minimum.)
EPGL	Extreme Pressure Gear Lube (oil) meeting API service classification GL-5 or MIL-Spec MIL-L-2105
HO	Hydraulic Oil. API service classification GL-3, e.g. Mobilfluid 424.
EO	Engine (crankcase) Oil. Gas - API SF, SH, SG class, MIL-L-2104. Diesel - API CC/CD class, MIL-L-2104B/MIL-L-2104C.

NOTICE

LUBRICATION INTERVALS ARE BASED ON MACHINE OPERATION UNDER NORMAL CONDITIONS. FOR MACHINES USED IN MULTI-SHIFT OPERATIONS AND/OR EXPOSED TO HOSTILE ENVIRONMENTS OR CONDITIONS, LUBRICATION FREQUENCIES MUST BE INCREASED ACCORDINGLY.

1. Swing Bearing

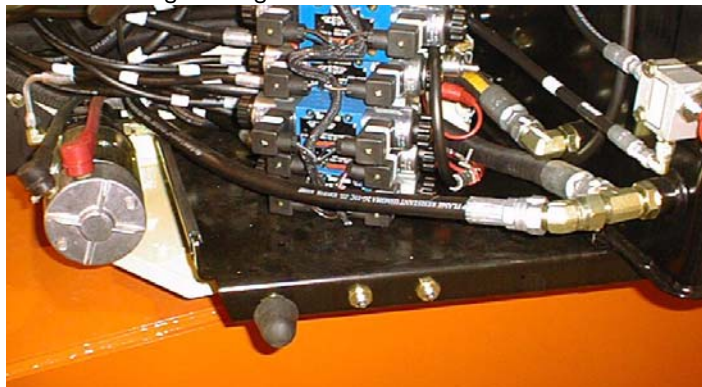

Lube Point(s) - 2 Grease Fittings
 Capacity - A/R
 Lube - MPG
 Interval - Every 3 months or 150 hrs of operation
 Comments - Remote Access

SECTION 6 - GENERAL SPECIFICATIONS & OPERATOR MAINTENANCE

2. Wheel Bearings

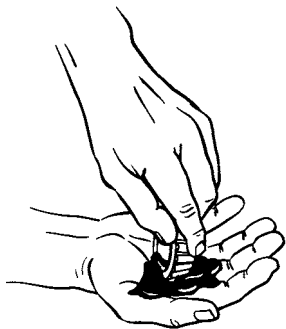

Lube Point(s) - Repack

Capacity - A/R

Lube - MPG

Interval - Every 2 years or 1200 hours of operation

3. Swing Drive Hub

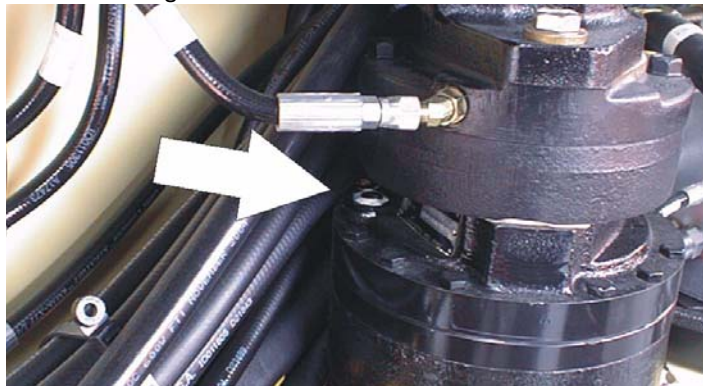

Lube Point(s) - Level/Fill Plug

Capacity - 17 oz. (1/2 Full)

Lube - EPGL

Interval - Check level every 3 months or 150 hrs of operation; change every 2 years or 1200 hours of operation

SECTION 6 - GENERAL SPECIFICATIONS & OPERATOR MAINTENANCE

4. Wheel Drive Hub

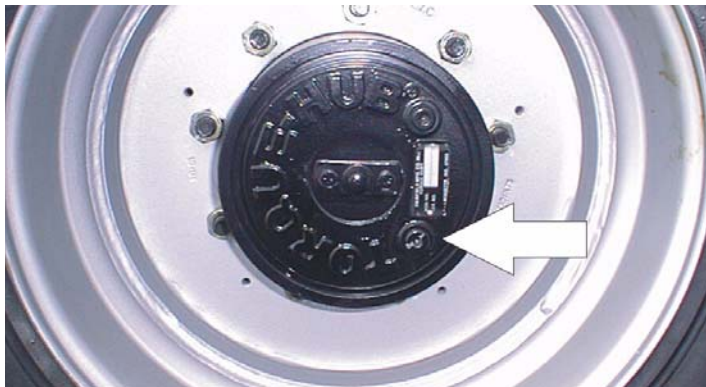

Lube Point(s) - Level/Fill Plug

Capacity - 17 oz. (1/2 Full)

Lube - EPGL

Interval - Check level every 3 months or 150 hrs of operation; change every 2 years or 1200 hours of operation

5. Hydraulic Return Filter

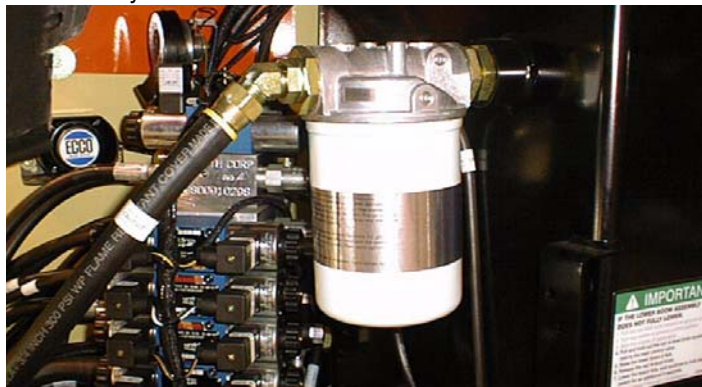

Interval - Change after first 50 hrs. and every 6 months or 300 hrs. thereafter or as indicated by Condition Indicator.

SECTION 6 - GENERAL SPECIFICATIONS & OPERATOR MAINTENANCE

6. Hydraulic Charge Filter



Interval - Change after first 50 hrs. and every 6 months or 300 hrs. thereafter or as indicated by Condition Indicator.

7. Hydraulic Tank

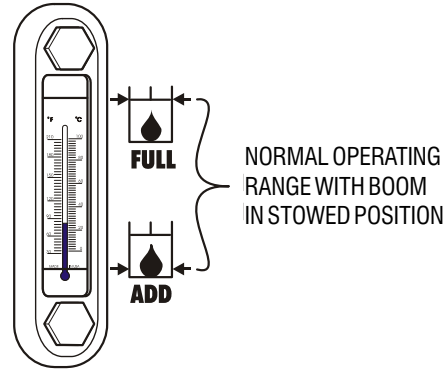

Lube Point(s) - Fill Cap

Capacity - 31 gal. (117.3 L) Tank; 37.2 gal. (140.8 L)

System

Lube - HO

Interval - Check Level daily; Change every 2 years or 1200 hours of operation.

SECTION 6 - GENERAL SPECIFICATIONS & OPERATOR MAINTENANCE

8. Suction Strainers (in tank)

REMOVE FILL CAP PLATE FROM
TANK TO GAIN ACCESS TO
STRAINERS

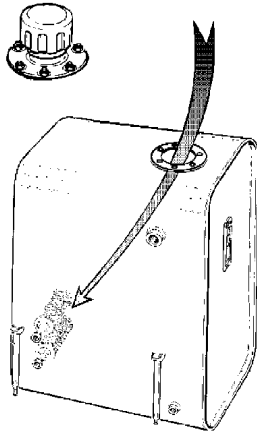

Lube Point(s) - 2

Interval - Every 2 years or 1200 hours of operation,
remove and clean at time of hydraulic oil change.

9. Oil Change w/Filter - Ford LRG423

Lube Point(s) - Fill Cap/Spin-on Element

Capacity - 5 Quarts

Lube - EO

Interval - 3 Months or 150 hours of operation

Comments - Check level daily/Change in accordance
with engine manual.

10. Oil Change w/Filter - Ford LRG425

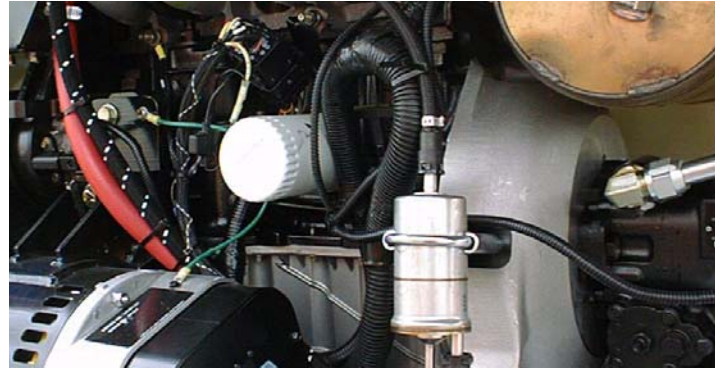

Lube Point(s) - Fill Cap/Spin-on Element

Capacity - 4.5 Quarts

Lube - EO

Interval - 3 Months or 150 hours of operation

Comments - Check level daily/Change in accordance
with engine manual.

SECTION 6 - GENERAL SPECIFICATIONS & OPERATOR MAINTENANCE

11. Oil Change w/Filter - Continental

Lube Point(s) - Fill Cap/Spin-on Element

Capacity - 6 Quarts

Lube - EO

Interval - 3 Months or 150 hours of operation

Comments - Check level daily/Change in accordance with engine manual.

12. Oil Change w/Filter - Deutz

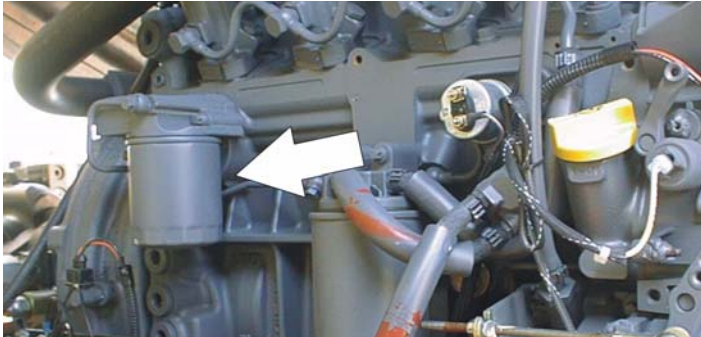

Lube Point(s) - Fill Cap/Spin-on Element

Capacity - 11 Quarts Crankcase; 5 Quarts Cooler

Lube - EO

Interval - Every Year or 1200 hours of operation

Comments - Check oil level, fill oil to max marking on the dipstick. Check level daily/Change in accordance with engine manual.

13. Oil Change w/Filter - Caterpillar

Lube Point(s) - Fill Cap/Spin-on Element

Capacity - 10.6 Quarts

Lube - EO

Interval - 3 Months or 150 hours of operation

Comments - Check level daily/Change in accordance with engine manual.

SECTION 6 - GENERAL SPECIFICATIONS & OPERATOR MAINTENANCE

14. Oil Change w/Filter - GM



Lube Point(s) - Fill Cap/Spin-on Element
(JLG P/N 7027965)
Capacity - 4.5 qt. (4.25 L) w/filter
Lube - EO
Interval - 3 Months or 150 hours of operation
Comments - Check level daily/Change in accordance
with engine manual.

15. Fuel Filter - Ford

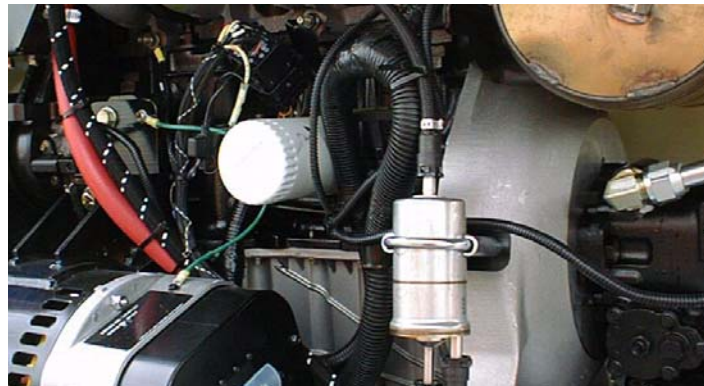

Lube Point(s) - Replaceable Element
Interval - Every Year or 1200 hours of operation

16. Fuel Filter - Continental

Lube Point(s) - Replaceable Element
Interval - Every Year or 600 hours of operation

SECTION 6 - GENERAL SPECIFICATIONS & OPERATOR MAINTENANCE

17. Fuel Filter - Deutz

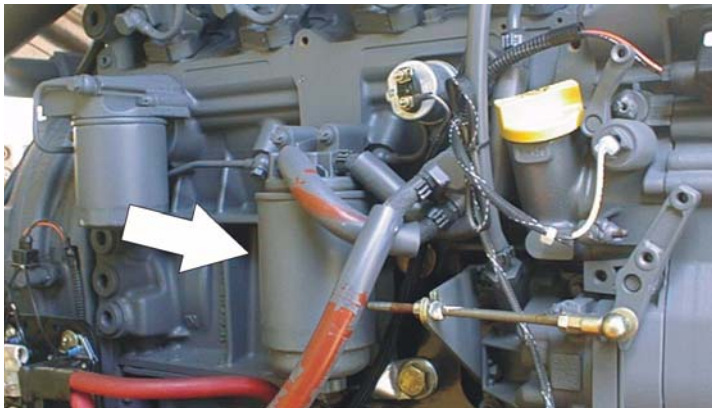

Lube Point(s) - Replaceable Element
Interval - Every Year or 600 hours of operation

18. Fuel Filter - Caterpillar

Lube Point(s) - Replaceable Element
Interval - Every Year or 600 hours of operation

19. Fuel Filter (Gasoline) - GM

Lube Point(s) - Replaceable Element
Interval - Every 6 months or 300 hours of operation

20. Air Filter

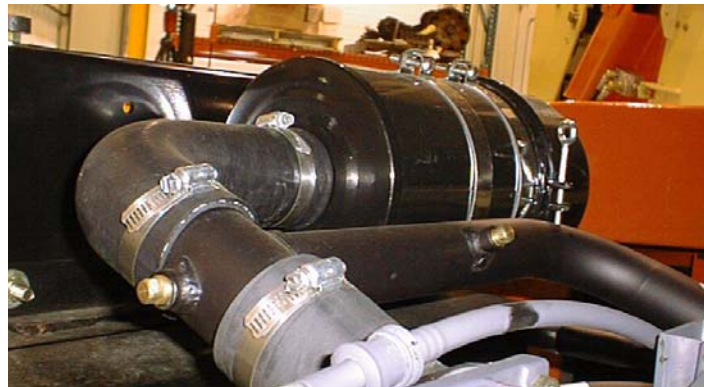

Lube Point(s) - Replaceable Element
Interval - Every 6 months or 300 hours of operation or as indicated by the condition indicator

SECTION 6 - GENERAL SPECIFICATIONS & OPERATOR MAINTENANCE

21. Electronic Pressure Regulator (LP only)

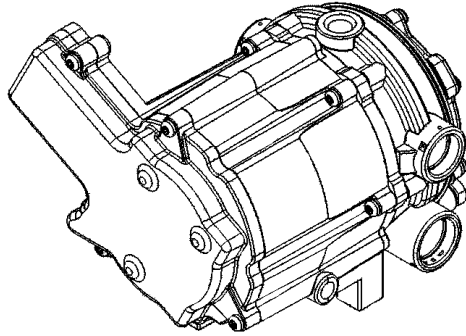

Interval - 3 Months or 150 hours of operation

Comments - Drain oil build up. Refer to Section 6.6, DRAINING OIL BUILD UP FROM THE PROPANE REGULATOR (Prior to S/N 0300132529)

22. Fuel Filter (Propane) - GM Engine



Interval - 3 Months or 150 hours of operation

Comments - Replace filter. Refer to Section 6.7, Propane Fuel Filter Replacement

6.4 TIRES & WHEELS

Tire Inflation

The air pressure for pneumatic tires must be equal to the air pressure that is stenciled on the side of the JLG product or rim decal for safe and proper operational characteristics.

Tire Damage

For pneumatic tires, JLG Industries, Inc. recommends that when any cut, rip, or tear is discovered that exposes sidewall or tread area cords in the tire, measures must be taken to remove the JLG product from service immediately. Arrangements must be made for replacement of the tire or tire assembly.

For polyurethane foam filled tires, JLG Industries, Inc. recommends that when any of the following are discovered, measures must be taken to remove the JLG product from service immediately and arrangements must be made for replacement of the tire or tire assembly.

- a smooth, even cut through the cord plies which exceeds 3 inches (7.5 cm) in total length
- any tears or rips (ragged edges) in the cord plies which exceeds 1 inch (2.5 cm) in any direction
- any punctures which exceed 1 inch in diameter

- any damage to the bead area cords of the tire

If a tire is damaged but is within the above noted criteria, the tire must be inspected on a daily basis to insure the damage has not propagated beyond the allowable criteria.

Tire Replacement

JLG recommends a replacement tire be the same size, ply and brand as originally installed on the machine. Please refer to the JLG Parts Manual for the part number of the approved tires for a particular machine model. If not using a JLG approved replacement tire, we recommend that replacement tires have the following characteristics:

- Equal or greater ply/load rating and size of original
- Tire tread contact width equal or greater than original
- Wheel diameter, width, and offset dimensions equal to the original
- Approved for the application by the tire manufacturer (including inflation pressure and maximum tire load)

Unless specifically approved by JLG Industries Inc. do not replace a foam filled or ballast filled tire assembly with a pneumatic tire. When selecting and installing a replacement tire, ensure that all tires are inflated to the pressure recommended

by JLG. Due to size variations between tire brands, both tires on the same axle should be the same.

Wheel Replacement

The rims installed on each product model have been designed for stability requirements which consist of track width, tire pressure, and load capacity. Size changes such as rim width, center piece location, larger or smaller diameter, etc., without written factory recommendations, may result in an unsafe condition regarding stability.

Wheel Installation

It is extremely important to apply and maintain proper wheel mounting torque.

WARNING

WHEEL NUTS MUST BE INSTALLED AND MAINTAINED AT THE PROPER TORQUE TO PREVENT LOOSE WHEELS, BROKEN STUDS, AND POSSIBLE DANGEROUS SEPARATION OF WHEEL FROM THE AXLE. BE SURE TO USE ONLY THE NUTS MATCHED TO THE CONE ANGLE OF THE WHEEL.

Tighten the lug nuts to the proper torque to prevent wheels from coming loose. Use a torque wrench to tighten the fasteners. If you do not have a torque wrench, tighten the fasteners with a lug wrench, then immediately have a service garage or dealer tighten the lug nuts to the proper torque. Over-tightening will result in breaking the studs or permanently deforming the mounting stud holes in the wheels. The proper procedure for attaching wheels is as follows:

1. Start all nuts by hand to prevent cross threading. DO NOT use a lubricant on threads or nuts.

SECTION 6 - GENERAL SPECIFICATIONS & OPERATOR MAINTENANCE

2. Tighten nuts in the following sequence:

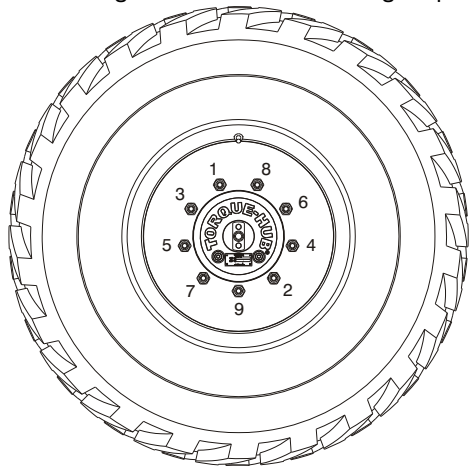

9 LUG PATTERN

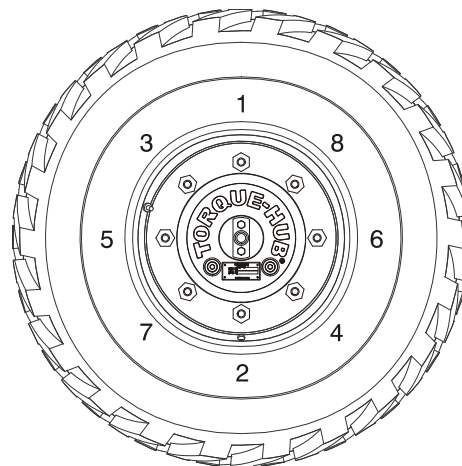

8 LUG PATTERN

3. The tightening of the nuts should be done in stages. Following the recommended sequence, tighten nuts per wheel torque chart.

Table 6-21. Wheel Torque Chart

TORQUE SEQUENCE		
1st Stage	2nd Stage	3rd Stage
40 ft. lbs. (55 Nm)	95 ft. lbs. (130 Nm)	170 ft. lbs. (230 Nm)

4. Wheel nuts should be torqued before first road use and after each wheel removal. Check and torque every 3 months or 150 hours of operation.

6.5 OSCILLATING AXLE LOCKOUT TEST (IF EQUIPPED)

NOTICE

LOCKOUT SYSTEM TEST MUST BE PERFORMED QUARTERLY, ANY TIME A SYSTEM COMPONENT IS REPLACED, OR WHEN IMPROPER SYSTEM OPERATION IS SUSPECTED.

NOTE: *Ensure boom is fully retracted, lowered, and centered between drive wheels prior to beginning lockout cylinder test.*

1. Place a 6 inches (15.2 cm) high block with ascension ramp in front of left front wheel.
2. From platform control station, start engine
3. Place the Drive control lever to the forward position and carefully drive machine up ascension ramp until left front wheel is on top of block.

SECTION 6 - GENERAL SPECIFICATIONS & OPERATOR MAINTENANCE

4. Carefully activate Swing control lever and position boom over right side of machine.
5. With boom over right side of machine, place Drive control lever to Reverse and drive machine off of block and ramp.
6. Have an assistant check to see that left front wheel remains locked in position off of ground.
7. Carefully activate Swing control lever and return boom to stowed position (centered between drive wheels). When boom reaches center, stowed position, lockout cylinders should release and allow wheel to rest on ground, it may be necessary to activate Drive to release cylinders.
8. Place the 6 inches (15.2 cm) high block with ascension ramp in front of right front wheel.
9. Place Drive control lever to Forward and carefully drive machine up ascension ramp until right front wheel is on top of block.
10. With boom over left side of machine, place Drive control lever to Reverse and drive machine off of block and ramp.
11. Have an assistant check to see that right front wheel remains locked in position off of ground.
12. Carefully activate Swing control lever and return boom to stowed position (centered between drive wheels). When boom reaches center, stowed position, lockout cylinders should release and allow wheel to rest on ground, it may be necessary activate Drive to release cylinders.
13. If lockout cylinders do not function properly, have qualified personnel correct the malfunction prior to any further operation.

6.6 DRAINING OIL BUILD UP FROM THE PROPANE REGULATOR (PRIOR TO S/N 0300132529)

During the course of normal operation oils may build inside the primary and secondary chambers of the propane pressure regulator. These oils may be a result of poor fuel quality, contamination of the fuel supply chain, or regional variation in the make up of the fuel. If the build up of the oil is significant this can effect the operation of the fuel control system. Refer to Section 6.3, Operator Maintenance for maintenance intervals. More frequent draining may be required if the fuel supply has been contaminated.

NOTICE

FOR BEST RESULTS WARM THE ENGINE TO OPERATING TEMPERATURE BEFORE DRAINING. THIS WILL ALLOW THE OILS TO FLOW FREELY FROM THE REGULATOR.

1. Move the equipment to a well ventilated area. Ensure there are no external ignition sources.
2. Start the engine and bring to operating temperature.
3. With the engine running, close the manual tank valve and run the engine out of fuel.

4. Push in the Emergency Switch once the engine stops.
5. Disconnect the electrical connection to the LPG fuel temperature sensor in the auxiliary fuel port of the EPR.



SECTION 6 - GENERAL SPECIFICATIONS & OPERATOR MAINTENANCE

6. Remove the retainer clip for the LPG fuel temperature sensor and remove the sensor from the regulator body.

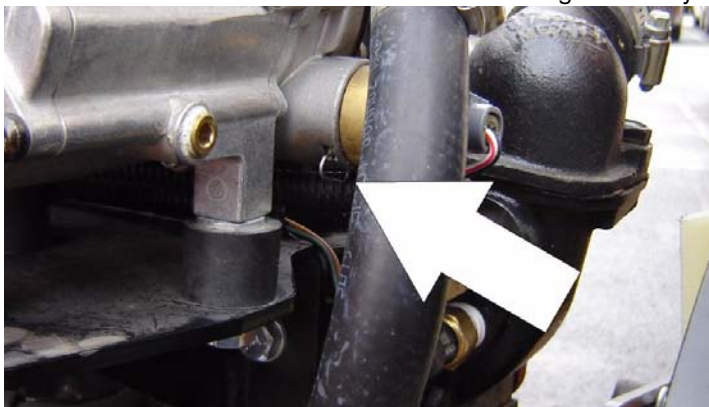

NOTE: Have a small container ready to collect oil that will drain freely from the regulator at this point.

7. Once all of the oil has been drained, reinstall the LPG fuel temperature sensor and reconnect the electrical connector.
8. Open the fuel tank manual valve.
9. Start the engine and verify all connections are secure.
10. Dispose of any drained oil per local regulations in a safe and proper fashion.

6.7 PROPANE FUEL FILTER REPLACEMENT

Removal

1. Relieve the propane fuel system pressure. Refer to Propane Fuel System Pressure Relief.
2. Disconnect the negative battery cable.
3. Slowly loosen the Filter housing and remove it.
4. Pull the filter housing from the Electric lock off assembly.
5. Remove the filter from the housing.
6. Locate Filter magnet and remove it.
7. Remove and discard the housing seal.
8. If equipped, remove and discard the retaining bolt seal.
9. Remove and discard mounting plate to lock off O-ring seal.

SECTION 6 - GENERAL SPECIFICATIONS & OPERATOR MAINTENANCE

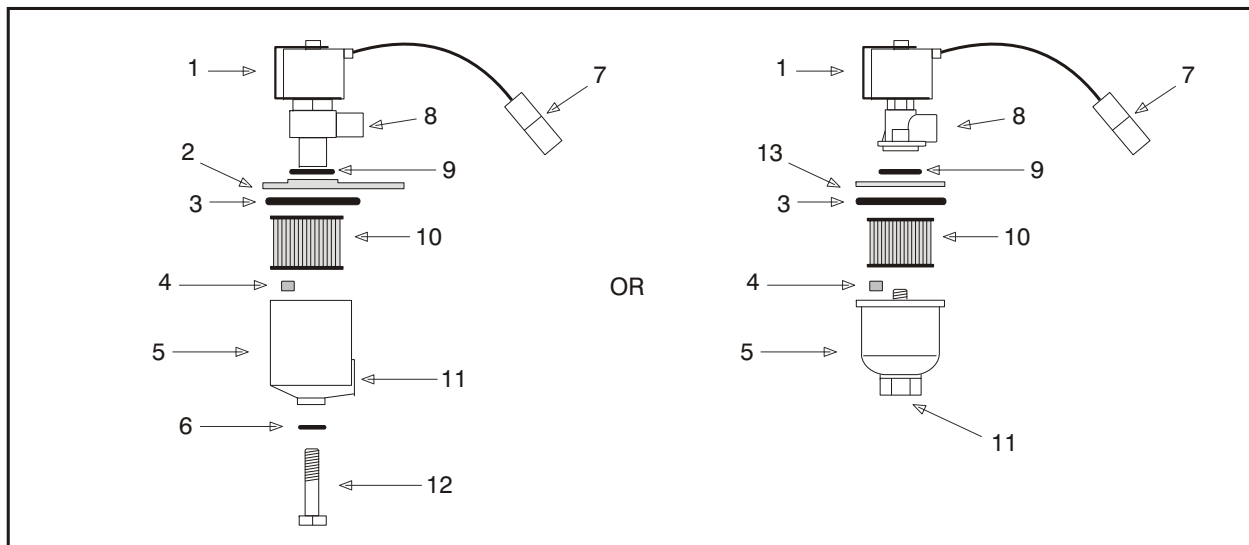

- | | | |
|-------------------------------|-------------------------|--------------------|
| 1. Electric Lock Off Solenoid | 6. Seal | 10. Filter |
| 2. Mounting Plate | 7. Electrical Connector | 11. Fuel Inlet |
| 3. Housing Seal | 8. Fuel Outlet | 12. Retaining Bolt |
| 4. Filter Magnet | 9. O-ring | 13. Ring |
| 5. Filter Housing | | |

Figure 6-11. Filter Lock Assembly

Installation

NOTICE

BE SURE TO REINSTALL THE FILTER MAGNET INTO THE HOUSING BEFORE INSTALLING NEW SEAL

1. Install the mounting plate to lock off O-ring seal.
2. If equipped, install the retaining bolt seal.
3. Install the housing seal.
4. Drop the magnet into the bottom of the filter housing.
5. Install the filter into the housing.
6. If equipped, install the retaining bolt into the filter housing.
7. Install the filter up to the bottom of the electric lock off.
8. Tighten the filter bowl retainer to 106 in lbs (12 Nm).
9. Open manual shut-off valve. Start the vehicle and leak check the propane fuel system at each serviced fitting. Refer to Propane Fuel System Leak Test.

6.8 PROPANE FUEL SYSTEM PRESSURE RELIEF

CAUTION

THE PROPANE FUEL SYSTEM OPERATES AT PRESSURES UP TO 312 PSI (21.5 BAR). TO MINIMIZE THE RISK OF FIRE AND PERSONAL INJURY, RELIEVE THE PROPANE FUEL SYSTEM PRESSURE (WHERE APPLICABLE) BEFORE SERVICING THE PROPANE FUEL SYSTEM COMPONENTS.

To relieve propane fuel system pressure:

1. Close the manual shut-off valve on the propane fuel tank.
2. Start and run the vehicle until the engine stalls.
3. Turn the ignition switch OFF.

CAUTION

RESIDUAL VAPOR PRESSURE WILL BE PRESENT IN THE FUEL SYSTEM. ENSURE THE WORK AREA IS WELL VENTILATED BEFORE DISCONNECTING ANY FUEL LINE.

6.9 SUPPLEMENTAL INFORMATION

The following information is provided in accordance with the requirements of the European Machinery Directive 2006/42/EC and is only applicable to CE machines.

For electric powered machines, the equivalent continuous A-Weighted sound pressure level at the work platform is less than 70dB(A)

For combustion engine powered machines, guaranteed Sound Power Level (LWA) per European Directive 2000/14/EC (Noise Emission in the Environment by Equipment for Use Outdoors) based on test methods in accordance with Annex III, Part B, Method 1 and 0 of the directive, is 104 dB.

The vibration total value to which the hand-arm system is subjected does not exceed $2,5 \text{ m/s}^2$. The highest root mean square value of weighted acceleration to which the whole body is subjected does not exceed $0,5 \text{ m/s}^2$.



An Oshkosh Corporation Company

TRANSFER OF OWNERSHIP

To Product Owner:

If you now own but ARE NOT the original purchaser of the product covered by this manual, we would like to know who you are. For the purpose of receiving safety-related bulletins, it is very important to keep JLG Industries, Inc. updated with the current ownership of all JLG products. JLG maintains owner information for each JLG product and uses this information in cases where owner notification is necessary.

Please use this form to provide JLG with updated information with regard to the current ownership of JLG products. Please return completed form to the JLG Product Safety & Reliability Department via facsimile or mail to address as specified below.

Thank You,

Product Safety & Reliability Department
JLG Industries, Inc.

13224 Fountainhead Plaza
Hagerstown, MD 21742
USA

Telephone: +1-717-485-6591
Fax: +1-301-745-3713

NOTE: Leased or rented units should not be included on this form.

Mfg. Model: _____

Serial Number: _____

Previous Owner: _____

Address: _____

Country: _____ Telephone: (____) _____

Date of Transfer: _____

Current Owner: _____

Address: _____

Country: _____ Telephone: (____) _____

Who in your organization should we notify?

Name: _____

Title: _____



WARNING:



The engine exhaust from this product contains chemicals known to the State of California to cause cancer, birth defects, or other reproductive harm.

1702961

PROPOSITION 65 WARNING

- **Battery posts, terminals and related accessories contain lead and lead compounds, chemicals known to the State of California to cause cancer and reproductive harm.**
- **Batteries also contain other chemicals known to the State of California to cause cancer.**
- **Wash hands after handling.**



An Oshkosh Corporation Company

Corporate Office
JLG Industries, Inc.
1 JLG Drive
McConnellsburg PA. 17233-9533
USA

(717) 485-5161

(717) 485-6417



3121204

JLG Worldwide Locations

JLG Industries (Australia)
P.O. Box 5119
11 Bolwarra Road
Port Macquarie
N.S.W. 2444
Australia

+61 2 65 811111

+61 2 65 810122

JLG Latino Americana Ltda.
Rua Eng. Carlos Stevenson,
80-Suite 71
13092-310 Campinas-SP
Brazil

+55 19 3295 0407

+55 19 3295 1025

JLG Industries (UK) Ltd
Bentley House
Bentley Avenue
Middleton
Greater Manchester
M24 2GP - England

+44 (0)161 654 1000

+44 (0)161 654 1001

JLG France SAS
Z.I. de Baulieu
47400 Fauillet
France

+33 (0)5 53 88 31 70

+33 (0)5 53 88 31 79

JLG Deutschland GmbH
Max-Planck-Str. 21
D - 27721 Ritterhude - Ihlpohl
Germany

+49 (0)421 69 350 20

+49 (0)421 69 350 45

JLG Equipment Services Ltd.
Rm 1107 Landmark North
39 Lung Sum Avenue
Sheung Shui N. T.
Hong Kong

(852) 2639 5783

(852) 2639 5797

JLG Industries (Italia) s.r.l.
Via Po. 22
20010 Pregnana Milanese - MI
Italy

+39 029 359 5210

+39 029 359 5845

Oshkosh-JLG Singapore Technology
Equipment Pte Ltd
29 Tuas Ave 4,
Jurong Industrial Estate
Singapore, 639379

+65-6591 9030



JLG Polska
Ul. Krolewska
00-060 Warszawa
Poland

+48 (0)914 320 245

+48 (0)914 358 200

JLG Industries (Scotland)
Wright Business Centre
1 Lonmay Road
Queenslie, Glasgow G33 4EL
Scotland

+44 (0)141 781 6700

+44 (0)141 773 1907

Plataformas Elevadoras
JLG Iberica, S.L.
Trapadella, 2
P.I. Castellbisbal Sur
08755 Castellbisbal, Barcelona
Spain

+34 93 772 4700

+34 93 771 1762

JLG Sverige AB
Enkopingsvagen 150
Box 704
SE - 176 27 Jarfalla
Sweden

+46 (0)850 659 500

+46 (0)850 659 534