

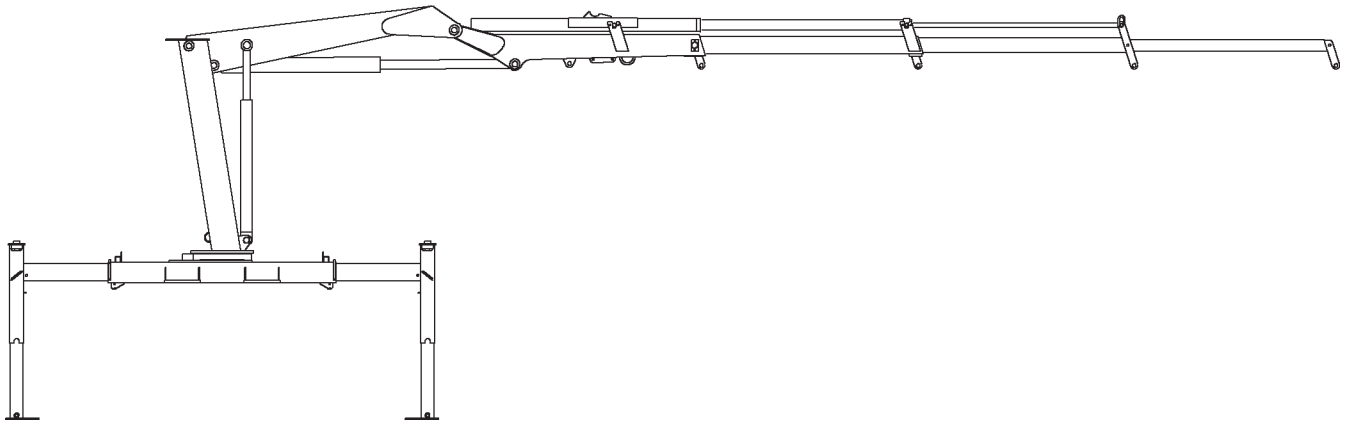

5200 Series Crane & Model 780 (Metric Version)

Volume 2 - PARTS AND SPECIFICATIONS

Section 1	SPECIFICATIONS-5200 SERIES
Section 1A.	SPECIFICATIONS-780 CRANE
Section 2	CRANE REFERENCE
Section 3	REPLACEMENT PARTS
Section 4	GENERAL REFERENCE



IOWA MOLD TOOLING CO., INC.

BOX 189, GARNER, IA 50438-0189

TEL: 641-923-3711

MANUAL PART NUMBER 99900922

Iowa Mold Tooling Co., Inc. is an Oshkosh Corporation company.

REVISIONS LIST

DATE	LOCATION	DESCRIPTION OF CHANGE
20001102	2-5	REV SPL
	3-10	ECN8615-41710920-CHG INNER CYL PN
	3-11	3B270000-REPLACE INNER CYL ASM
	3-25	91710962-CHG BOM & DWG (NEW CBAL VALVE)
20010109	3-25	ECN9000-91710962-ADD HOSE 29.51395954, DELETE 1 4.51393922 HOSE, CHG DWG
20010215	2-05-06	UPDATE SPARE PARTS LIST
20010417	3-43	ITEM #5 77041345 WAS 77041014
20010419	2-6	CHG ASM DESIGNATION 90713554 TO 91716707
20010419	2-6	CHG ASM DESIGNATION 90713554 TO 90716707
	3-31	REMOVED DRAWING 90713554 AND ADDED 90716707
	3-32	ADDED SECOND DRAWING OF 90716707 ON NEW PAGE
	3-1	REVISED INDEX
20010907	3-25	ECN 8758 ADDED ITEM 30 TO HYDRAULIC KIT 91710962
20011023	3-47 THROUGH 52	ECN 8783 ADDED RADIO RMT KIT
20011204	3-5,20	ADDED MOBILTAC LUBRICATION NOTE
	3-38,39	ECN 8794 - NEW OVERLOAD VALVE BLOCK
	3-44	ECN 8834 - NEW LIGHT KIT
20020318	3-39	ECN 9996 - ADDED 31717516 CAP ALERT KIT
20020724	3-26	ECN 8972 - ADDED HYD SCHEMATIC FOR SELECTOR VALVE
	3-37	ECN 8972 - WINCH KIT 31717776 REPLACES 31705009
	3-40	ECN 8973 - CHANGES TO CAP ALERT/SHUTDOWN KITS
	3-45	ECN 8972 - BOM CHANGES TO 31717218 FLOOD LIGHT KIT
	3-1,2,27 ON	ECN 8972 - UPDATED TOC FOR NEW PAGE
20030715	3-40	ECN 9201 - CHANGES TO CAP SHUTDOWN KIT
20040527	3-13	ECN 9468 - CHANGE TO ROD ASM ON 3C180920
20051104	3-4,6,7,14,15	ECN 9832 - CYL CHANGE 71411814 REPL. 3B221850; 71411815 REPL. 3C180920
	3-27	ECN 9843 - VALVE ADDED TO 91710962 HYD KIT
20060616	3-4,12,19	ECN 9832-2 - REVERSED CYLINDER CHANGE
20061020	1-1	UPDATED OWNERSHIP STATEMENT. ECN 10300-1, CHANGED HOOK ON 41710943, 41710939
20070816	3-4	ECN 10539 - UPDATED BOLT LENGTHS #36,68 IN 41712219
20081104	3-4,19	ECN 10767 - HARDENED TEETH ON TURNTABLE GEAR
	3-51	ECN 10903 - 51717059 UPDATE.
20100322	3-51	ECN 11213 - ADDED RELAY TO 51717059 JIC BOX ASSEMBLY
20110928	3-37	ECN 11299 - REVISED WINCH FITTINGS
20111219	SECTIONS 1-4	ECN 11628 - UPDATE STABILIZER WORDING.
	3-27	ECN 11621 - ADDED HYD OVERLOAD KIT
	3-41	ECN 11606 - ADDED TWO-BLOCK DAMAGE PREVENTION KIT
20120419	3-6,13,18, 35	ECN 11615 - REPLACED WAFER LOCK WITH STOP TUBE IN CYLINDERS, ADDED REMOTE CALI BRATION PROCEDURE
20120531	3-38	ECN 11736 - UPDATED WINCH KIT

INTRODUCTION

This volume deals with information applicable to your particular crane. For operating, maintenance and repair instructions, refer to Volume 1, OPERATION, MAINTENANCE AND REPAIR.

We recommend that this volume be kept in a safe place in the office.

This manual is provided to assist you with ordering parts for your IMT crane. It also contains additional instructions regarding your particular installation.

It is the user's responsibility to maintain and operate this unit in a manner that will result in the safest working conditions possible.

Warranty of this unit will be void on any part of the unit subjected to misuse due to overloading, abuse, lack of maintenance and unauthorized modifications. No warranty - verbal, written or implied - other than the official, published IMT new machinery and equipment warranty will be valid with this unit.

In addition, it is also the user's responsibility to be aware of existing Federal, State and Local codes and

regulations governing the safe use and maintenance of this unit. Listed below is a publication that the user should thoroughly read and understand.

ANSI/ASME B30.22
ARTICULATING BOOM CRANES
The American Society of Mechanical Engineers
United Engineering Center
345 East 47th Street
New York, NY 10017

Three means are used throughout this manual to gain the attention of personnel. They are NOTE's, CAUTION's and WARNING's and are defined as follows:

NOTE

A NOTE is used to either convey additional information or to provide further emphasis for a previous point.

CAUTION

A CAUTION is used when there is the very strong possibility of damage to the equipment or premature equipment failure.

WARNING

A WARNING is used when there is the potential for personal injury or death.

Treat this equipment with respect and service it regularly. These two things can add up to a safer working environment.

**Read and familiarize yourself with the
IMT OPERATOR'S CRANE SAFETY MANUAL
before operating or performing any maintenance
on your crane.**

SECTION 1. 5200 SERIES CRANE SPECIFICATIONS

GENERAL	3
PERFORMANCE CHARACTERISTICS	4
POWER SOURCE	4
CYLINDER HOLDING VALVES	4
ROTATION SYSTEM	4
HYDRAULIC SYSTEM	4
STOWED POSITION & STABILIZER DIMENSIONS-1H EXT-5200 SERIES	5
HOOK APPROACH DIMENSIONS-1H EXT-5200 SERIES	5
GEOMETRIC CONFIGURATION-1H EXT-5200 SERIES	6
GEOMETRIC CONFIGURATION-2H & 2H/1M EXT-5200 SERIES	7
HOOK APPROACH DIMENSIONS-2H/1M EXT-5200 SERIES	8
STOWED POSITION & STABILIZER DIMENSIONS-2H/1M EXT-5200 SERIES	8
CAPACITY CHART-5200 SERIES CRANE	9
MINIMUM CHASSIS SPECIFICATIONS -	10

5200 SERIES CRANE SPECIFICATIONS

GENERAL

	5200 SERIES CRANE		
	1H	2H	2H1M
*CRANE RATING (ANSI B30.22)	52000 ft-lbs	52000 ft-lbs	51330 ft-lbs
*MAXIMUM CRANE RATING	52560 ft-lbs	52060 ft-lbs	52000 ft-lbs
HORIZONTAL REACH from centerline of rotation	20'-1"	26'-4"	32'-2"
HYDRAULIC EXTENSION	70"	70" X 2	70" X 2
MANUAL EXTENSION	None	None	70"
VERTICAL REACH from mounting surface	26'-6"	32'-4"	37'-10"
VERTICAL REACH from ground / 40" frame ht.	29'-10"	35'-8"	41'-2"
CRANE WEIGHT	2820 lbs	3060 lbs	3140 lbs
STABILIZER SPAN	12'-4"	12'-4"	12'-4"
STABILIZER PADS	12" x 12"	12" x 12"	12" x 12"
CRANE STORAGE HEIGHT from mounting surface	7'-0"	7'-0"	7'-0"
CRANE STORAGE HEIGHT from ground / 40" frame ht.	10'-4"	10'-4"	10'-4"
**MOUNTING SPACE REQUIRED	28"	28"	28"
ROTATIONAL TORQUE	7800 ft-lbs	7800 ft-lbs	7800 ft-lbs
OPTIMUM PUMP CAPACITY	9 U.S. GPM	9 U.S. GPM	9 U.S. GPM
SYSTEM OPERATING PRESSURE	2500 PSI	2500 PSI	2500 PSI
OIL RESERVOIR CAPACITY	17 U.S. Gallons	17 U.S. Gallons	17 U.S. Gallons
HOOK APPROACH - HORIZONTAL from centerline of rotation	2'-11"	3'-1"	3'-1"
HOOK APPROACH - VERTICAL from mounting surface	6'-9"	6'-4"	6'-4"

* Maximum Crane Rating (ft-lbs) is defined as that rated load (lbs) which when multiplied by its respective distance (ft) from centerline of rotation gives the greatest ft-lb value.

ANSI B30.22 Crane Rating (ft-lbs) = With all extensions retracted and inner plus outer boom in a horizontal position, rated load (lbs) X respective distance (ft) from centerline of rotation = nominal ft-lb value.

** Allow an additional 5" between the cab and crane base for swing clearance.

PERFORMANCE CHARACTERISTICS

ROTATION:	450°	30 seconds
INNER BOOM ELEVATION:	-49° to +77°	24 seconds
OUTER BOOM ARTICULATION:	139°	21 seconds
TELESCOPIC EXTENSIONS:	70"/70"	26 / 15 seconds
SINGLE STAGE EXTENSION:	70"	15 seconds
VERTICAL STABILIZER STROKE:	24"	6 seconds

POWER SOURCE

Integral-mounted hydraulic pump and PTO application. Other standard power sources may be utilized - minimum power required is 17 horsepower.

CYLINDER HOLDING VALVES

The holding sides of all standard cylinders are equipped with integral-mounted holding or counter-balance valves to prevent sudden cylinder collapse in case of hose or other hydraulic failure. The stabilizer cylinders have positive, pilot-operated holding valves that open only on command.

The inner cylinders have single pilot-operated counter balance valves while the outer and extension boom cylinders have double counter-balance valves. The counter-balance valve serves several functions. First, it is a holding valve. Secondly, it is so constructed that it will control the lowering function and allow that motion to be feathered while under load. Finally, if a hose breaks, the only oil loss will be that in the hose.

ROTATION SYSTEM

Rotation of the crane is accomplished through a turntable bearing, powered by a high torque hydraulic motor through a ring and pinion type spur gear train. Total gear reduction is 39.61 : 1.

HYDRAULIC SYSTEM

The hydraulic system is an open centered, full pressure system, requiring 9 GPM optimum oil flow, at 2500 PSI. Eight-spool, stack-type control valve, six of which are used for the standard crane and the remaining two are plugged, but easily adapted for additional optional features. Dual operational handles for six functions are located at both sides of crane for convenient operation. System includes hydraulic oil reservoir, suction-line strainer, pump, 8-section control valve, return-line filter and all hoses and fittings.

IMT reserves the right to change specifications and design without notice.

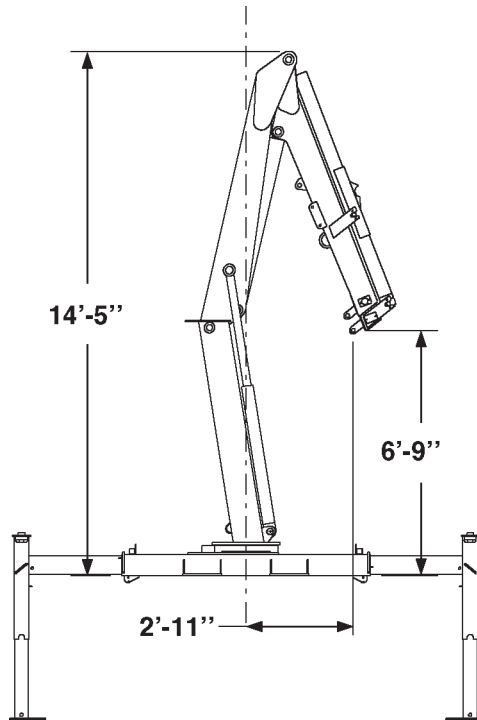

HOOK APPROACH DIMENSIONS-1H EXT-5200 SERIES

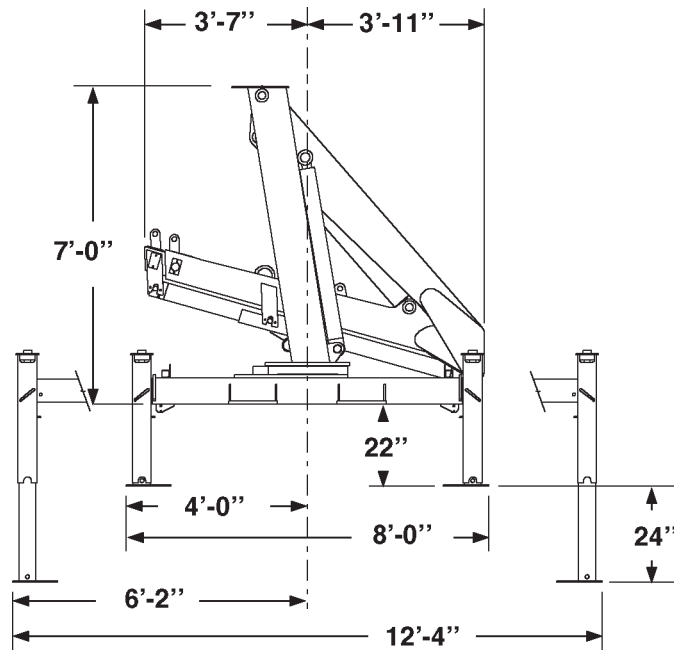

STOWED POSITION & STABILIZER DIMENSIONS-1H EXT-5200 SERIES

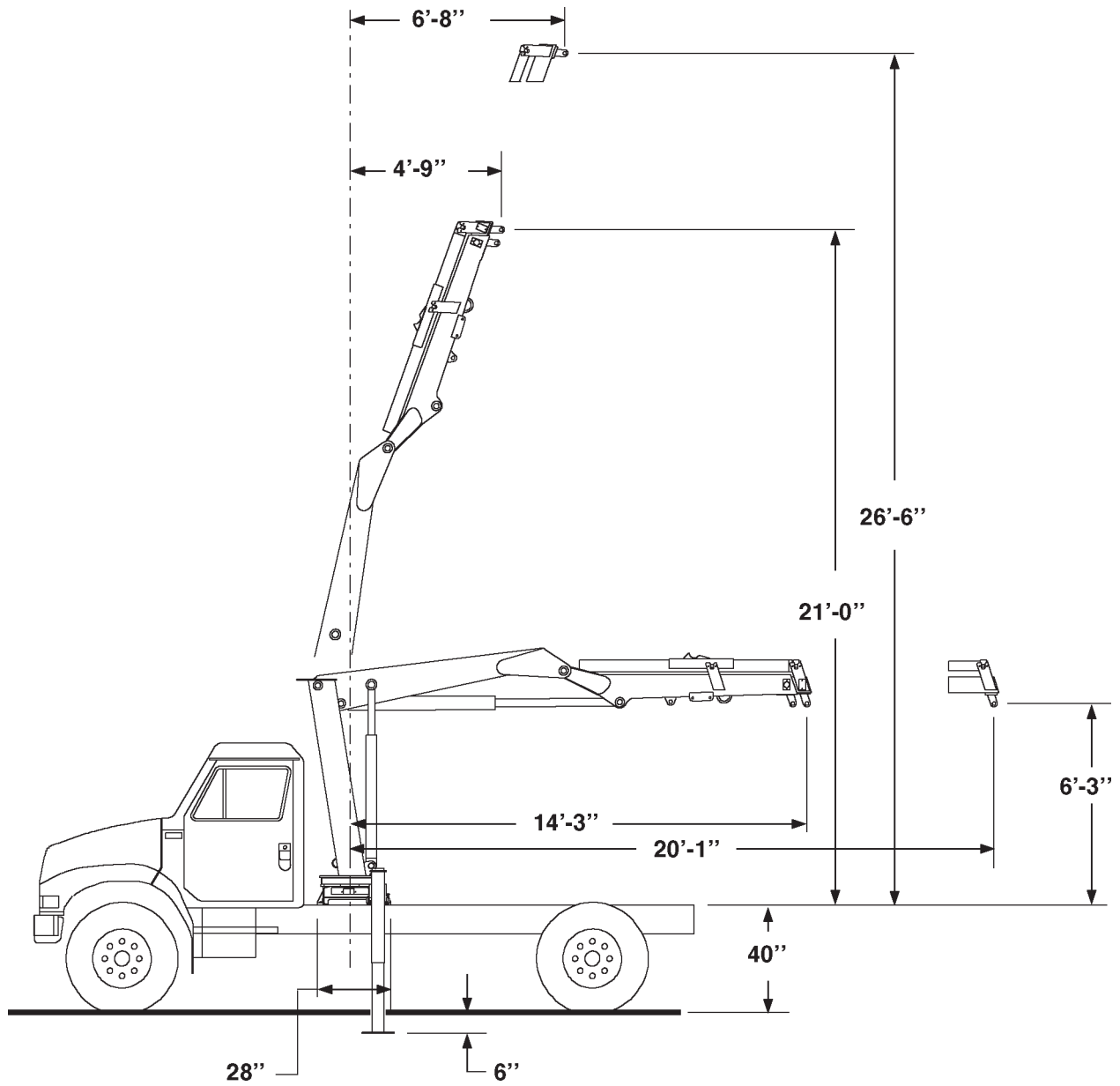

GEOMETRIC CONFIGURATION-1H EXT-5200 SERIES

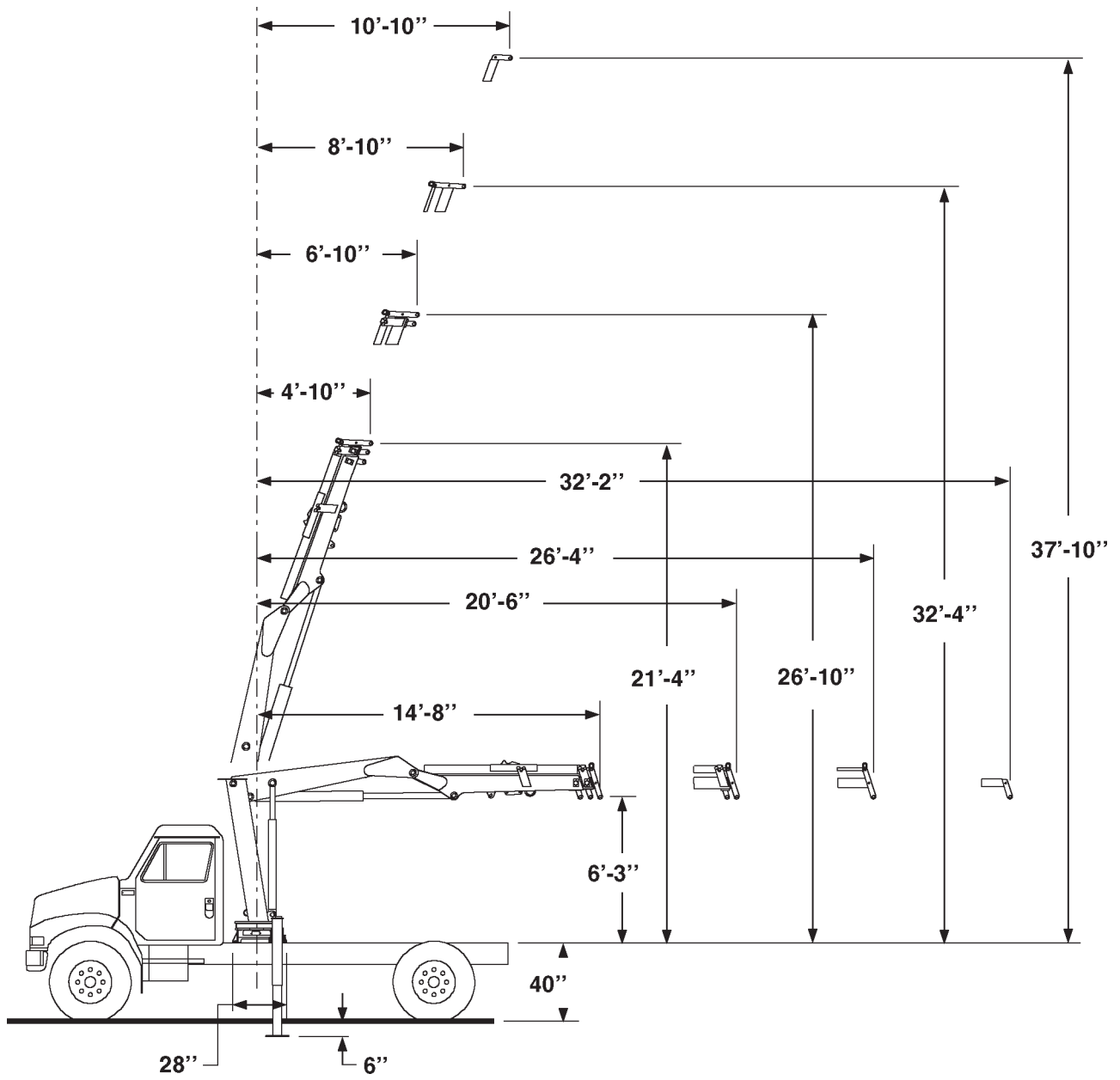

GEOMETRIC CONFIGURATION-2H & 2H/1M EXT-5200 SERIES

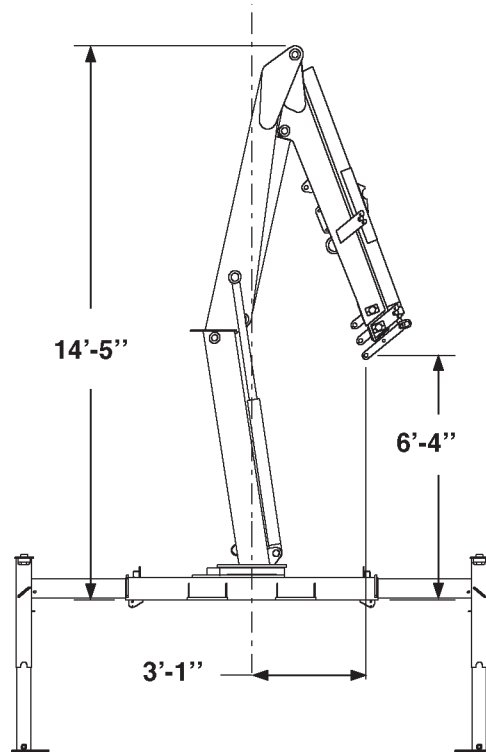

HOOK APPROACH DIMENSIONS-2H/1M EXT-5200 SERIES

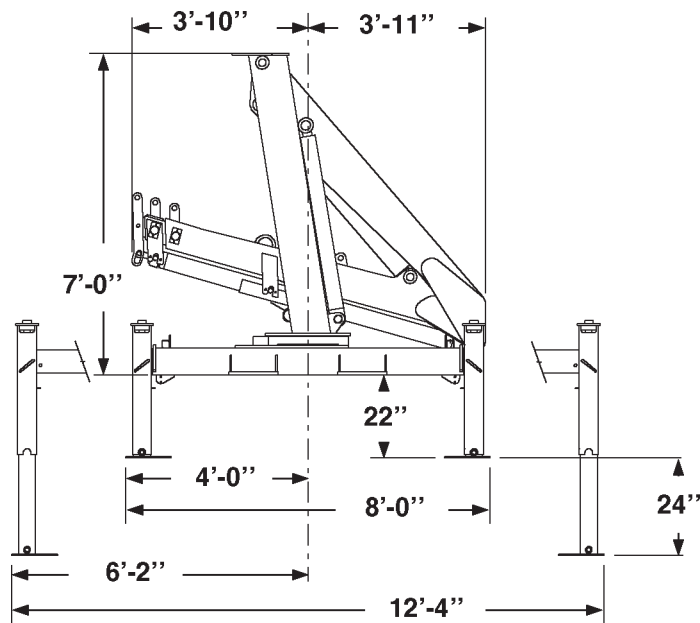

STOWED POSITION & STABILIZER DIMENSIONS-2H/1M EXT-5200 SERIES

IOWA MOLD TOOLING CO., INC. ● BOX 189 ● GARNER ● IA ● 50438 ● 641-923-3711

Capacities through geometric range are limited to those shown in horizontal position.



- Loads shown are based on crane structural or hydraulic capability. Before lift is made, stability must be checked per SAE J765A.
- Working loads will be limited to those shown. Deduct the weight of load handling devices.
- Winch lifting capacity is limited to those shown - Maximum 4000 LBS for 1-part line.

5200 Series Crane

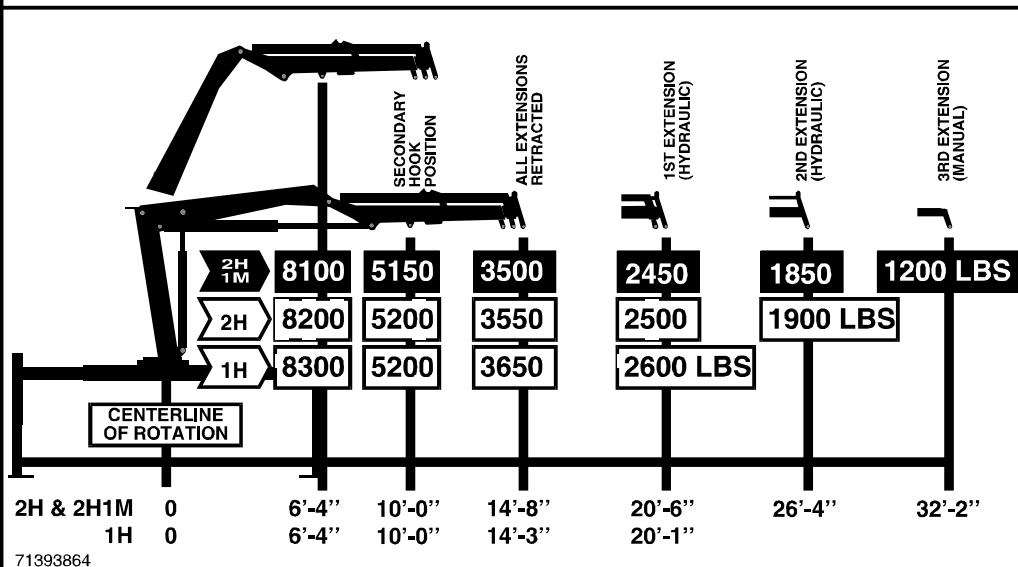
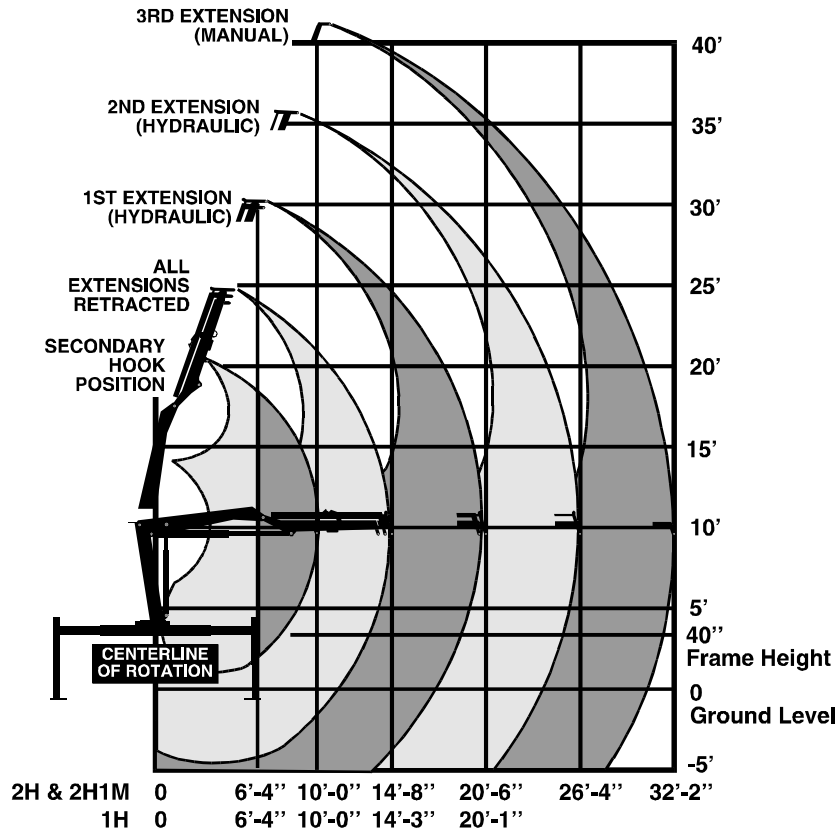

71393864

CAPACITY CHART-5200 SERIES CRANE

MINIMUM CHASSIS SPECIFICATIONS - FOR STANDARD 5200 SERIES CRANE

Crane Mount	Behind Cab
Crane Working Area	360°
Chassis Style	Conventional Cab
Front Axle Rating (GAWR)	7000 lbs
Rear Axle Rating (GAWR)	Single Axle 14,000 lbs
Wheelbase	171"
Cab-to-axle	102"
Stabilizer Width Required	12'-4"
RBM	720,000 in-lbs
Frame Section Modulus	14.4 cubic inches
Frame Yield Strength	50,000 psi
Minimum Finished Unit Weight To Maintain Vehicle Stability	
Front Axle	* 5300 lbs
Rear Axle	* 6100 lbs
Total Finished Unit Wt.	11400 lbs

* Allows lifting full capacity load in a 360° arc when crane is installed immediately behind the cab. Great care should be taken when swinging the load from rear of vehicle to front of vehicle since the front axle springs will compress, thus affecting the levelness of the vehicle.

**FIGURE A.
360° WORKING AREA**

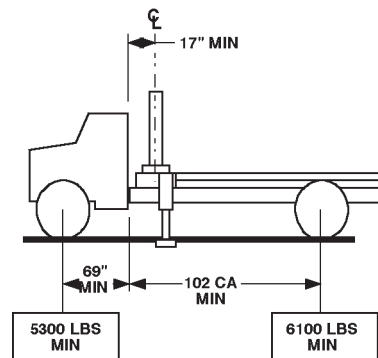

NOTES:

1. GAWR means Gross Axle Weight Rating and is dependent on all components of the vehicle such as axles, tires, wheels, springs, brakes, steering and frame strength meeting the manufacturer's recommendations. Always specify GAWR when purchasing a truck.
2. Minimum axle requirements may increase with use of diesel engines, longer wheelbase or service bodies. Contact the factory for further information.
3. Weight distribution calculations are required to determine final axle loading.
4. All chassis and crane combinations must be stability tested to ensure stability per ANSI B30.22

SECTION 1A. MODEL 780 CRANE SPECIFICATIONS

GENERAL	3
PERFORMANCE CHARACTERISTICS	3
POWER SOURCE	3
CYLINDER HOLDING VALVES	4
ROTATION SYSTEM	4
HYDRAULIC SYSTEM	4
SELECTED WEIGHTS OF ANCILLARY EQUIPMENT	4
HOOK APPROACH DIMENSIONS (1 HYD EXTENSION)	5
GEOMETRIC CONFIGURATION -1 HYD EXTENSION -MODEL 780 CRANE	5
STOWED POSITION AND STABILIZER DIMENSIONS (1 HYD EXTENSION)	5
HOOK APPROACH DIMENSIONS-2H/1M	6
GEOMETRIC CONFIGURATION-2HYD & 2HYD/1MNL EXTENSIONS-MODEL 780 CRANE	6
STOWED POSITION AND STABILIZER DIMENSIONS - 2H/1M	6
CAPACITY CHART-MODEL 780 CRANE	7

MODEL 780 CRANE SPECIFICATIONS

GENERAL

	780-1H	780-2H	780-2H1M
CRANE RATING (ANSI B30.22)	7 ton-meters	7 ton-meters	7 ton-meters
HORIZONTAL REACH from centerline of rotation	6.12m	8.03m	9.80m
HYDRAULIC EXTENSION	178cm	178cm x 2	178cm x 2
MANUAL EXTENSION	None	None	178cm
VERTICAL REACH from mounting surface	8.08m	9.86m	11.53m
VERTICAL REACH from ground / 102cm frame ht.	9.09m	10.87m	12.55m
**BASE CRANE WEIGHT	1090kg	1200kg	1235kg
STABILIZER SPAN	3.76m	3.76m	3.76m
STABILIZER PADS	30 x 30cm	30 x 30cm	30 x 30cm
CRANE STORAGE HEIGHT from mounting surface	2.13m	2.13m	2.13m
CRANE STORAGE HEIGHT from ground / 102cm frame ht.	3.15m	3.15m	3.15m
*MOUNTING SPACE REQUIRED	71cm	71cm	71cm
ROTATIONAL TORQUE	1120 kg-m	1120 kg-m	1120 kg-m
OPTIMUM PUMP CAPACITY	34 liters/minute	34 liters/minute	34 liters/minute
SYSTEM OPERATING PRESSURE	172 bar	172 bar	172 bar
OIL RESERVOIR CAPACITY	64 liters	64 liters	64 liters
HOOK APPROACH - HORIZONTAL from centerline of rotation	89cm	94cm	94cm
HOOK APPROACH - VERTICAL from mounting surface	2.06m	1.93m	1.93m

* Allow an additional 8cm between the cab and crane base for swing clearance.

** Without stabilizers, hydraulic oil reservoir and mounting accessories.

PERFORMANCE CHARACTERISTICS

ROTATION:	450°/7.85 Rad.	30 seconds
INNER BOOM ELEVATION:	-49° to +77°/-0.86 to 1.34 Rad.	24 seconds
OUTER BOOM ARTICULATION:	139°/2.43 Rad.	21 seconds
TELESCOPIC EXTENSIONS:	178/178cm	26 / 15 seconds
SINGLE STAGE EXTENSION:	178cm	15 seconds
VERTICAL STABILIZER STROKE:	61cm	7 seconds

POWER SOURCE

Integral-mounted hydraulic pump and PTO application. Other standard power sources may be utilized - minimum power required is 17 horsepower.

CYLINDER HOLDING VALVES

The holding sides of all standard cylinders are equipped with integral-mounted holding or counter-balance valves to prevent sudden cylinder collapse in case of hose or other hydraulic failure. The stabilizer cylinders have positive, pilot-operated holding valves that open only on command.

The inner cylinders have single pilot-operated counter balance valves while the outer and extension boom cylinders have double counter-balance valves. The counter-balance valve serves several functions. First, it is a holding valve. Secondly, it is so constructed that it will control the lowering function and allow that motion to be feathered while under load. Finally if a hose breaks, the only oil loss will be that in the hose.

ROTATION SYSTEM

Rotation of the crane is accomplished through a turntable bearing, powered by a high torque hydraulic motor through a ring and pinion type spur gear train. Total gear reduction is 39.61 : 1.

HYDRAULIC SYSTEM

The hydraulic system is an open centered, full pressure system, requiring 34 liters/minute optimum oil flow, at 172 bar. Eight-spool, stack-type control valve, six of which are used for the standard crane and the remaining two are plugged, but easily adapted for additional optional features. Dual operational handles for six functions are located at both sides of crane for convenient operation. System includes hydraulic oil reservoir, suction-line strainer, pump, 8-section control valve, return-line filter and all hoses and fittings.

SELECTED WEIGHTS OF ANCILLARY EQUIPMENT

STABILIZERS	167 kg
HYDRAULIC OIL RESERVOIR	23 kg

IMT reserves the right to change specifications and design without notice.



IOWA MOLD TOOLING CO., INC.

BOX 189, GARNER, IA 50438-0189

TEL: 641-923-3711

FAX: 641-923-2424

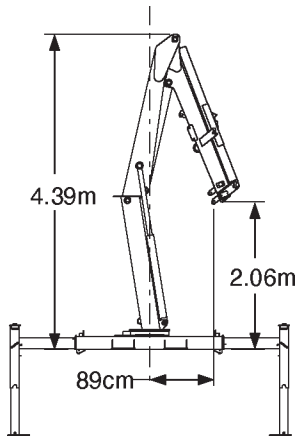

**HOOK APPROACH DIMENSIONS
(1 HYD EXTENSION)**

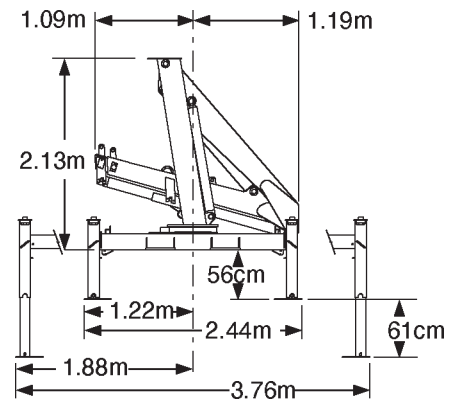

**STOWED POSITION AND STABILIZER
DIMENSIONS (1 HYD EXTENSION)**

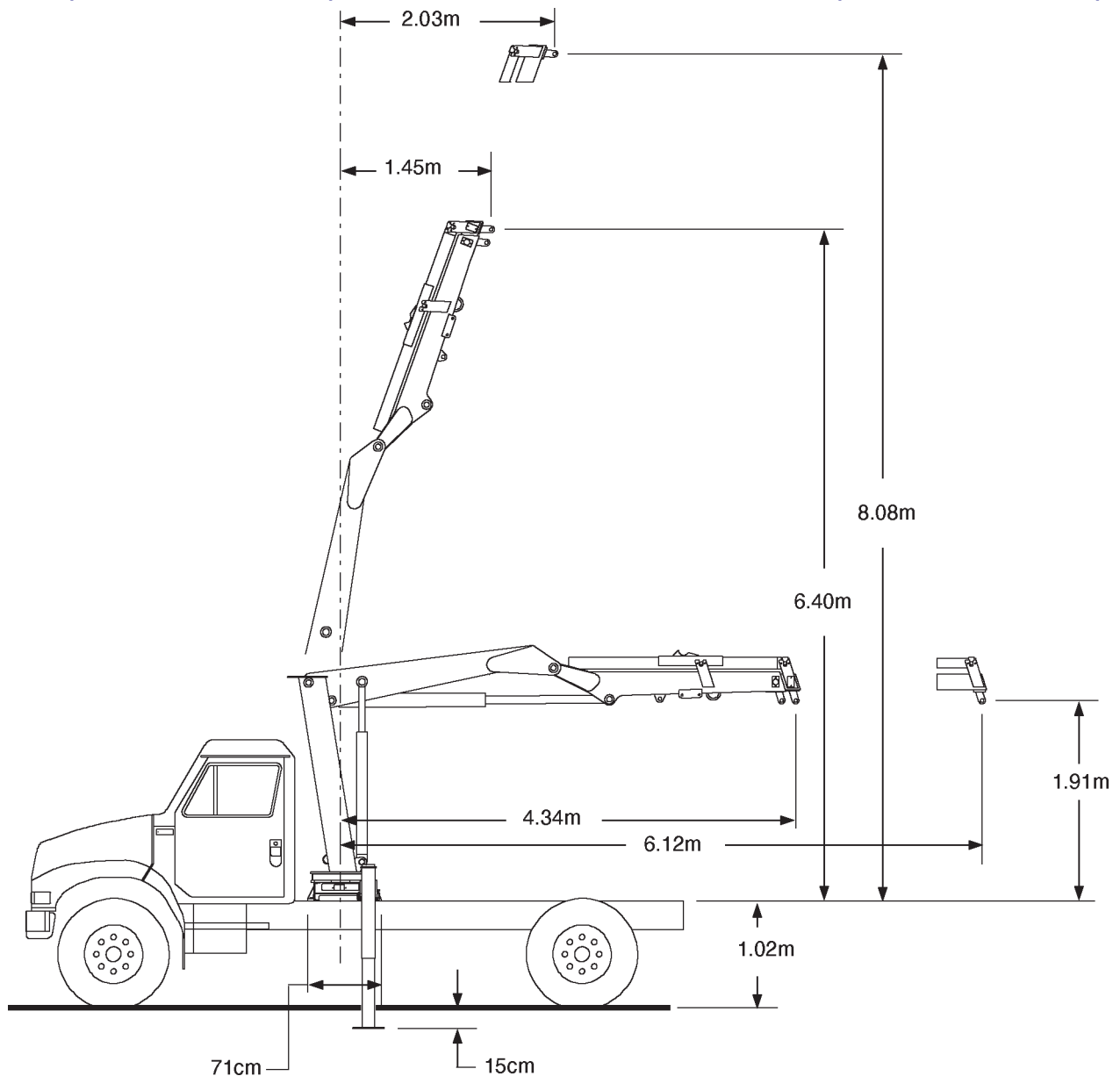

GEOMETRIC CONFIGURATION -1 HYD EXTENSION - MODEL 780 CRANE

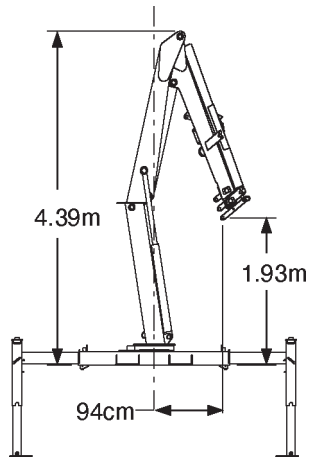

HOOK APPROACH DIMENSIONS-2H/1M

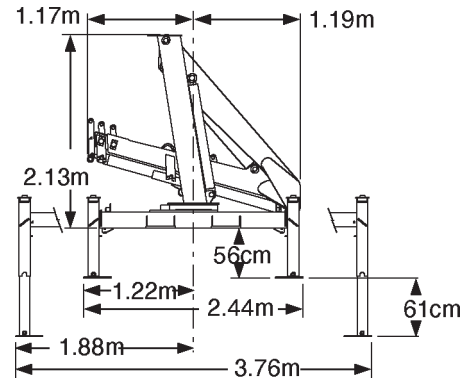

STOWED POSITION AND STABILIZER DIMENSIONS - 2H/1M

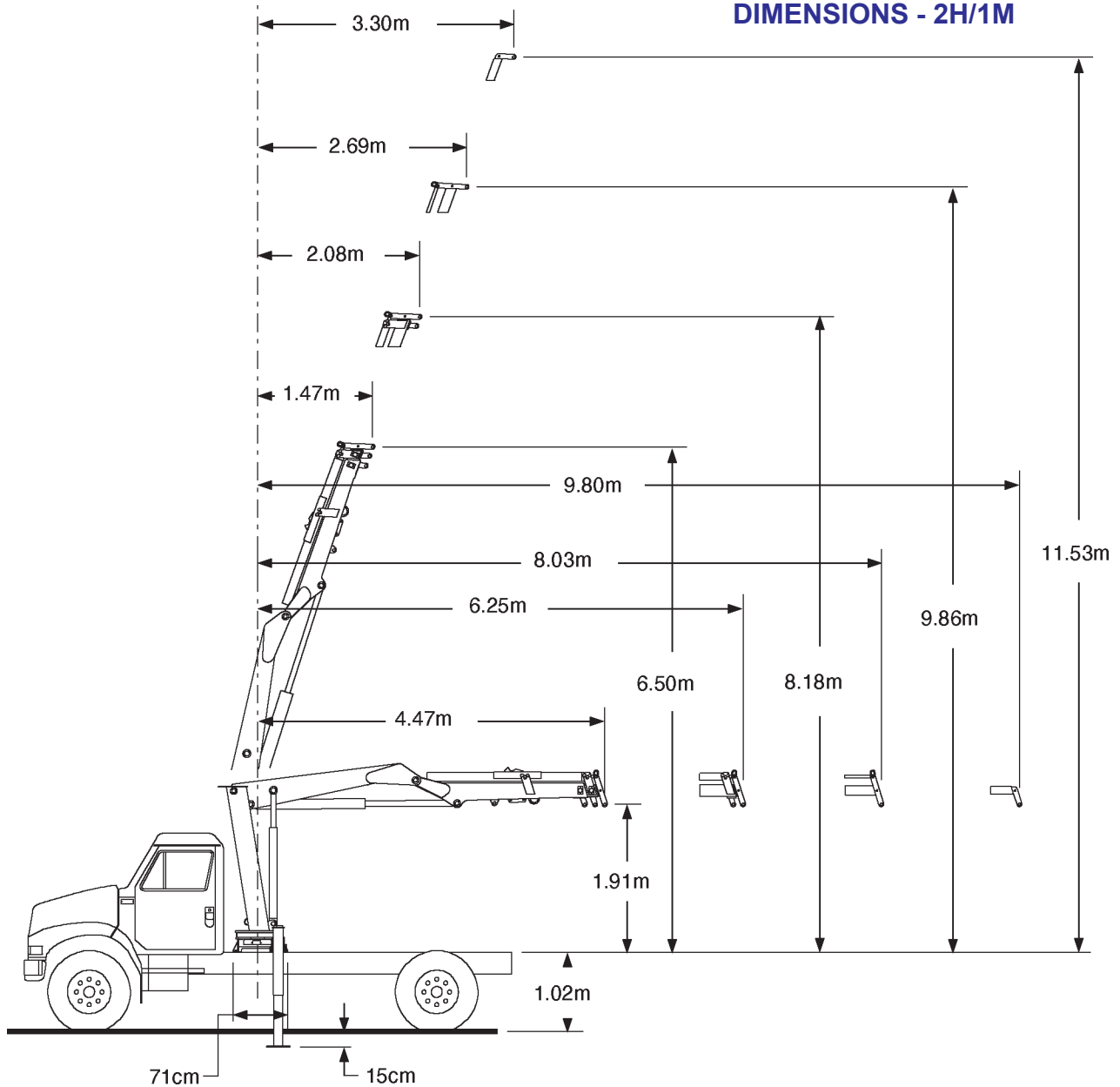

GEOMETRIC CONFIGURATION-2HYD & 2HYD/1MNL EXTENSIONS-MODEL 780 CRANE

IOWA MOLD TOOLING CO., INC. ● BOX 189 ● GARNER ● IA ● 50438 ● 641-923-3711

Capacities through geometric range are limited to those shown in horizontal position.



MODEL 780

- Loads shown are based on crane structural or hydraulic capability. Before lift is made, stability must be checked per SAE J765A.
- Working loads will be limited to those shown. Deduct the weight of load handling devices.
- Winch lifting capacity is limited to those shown - Maximum 1815 KG for 1-part line.

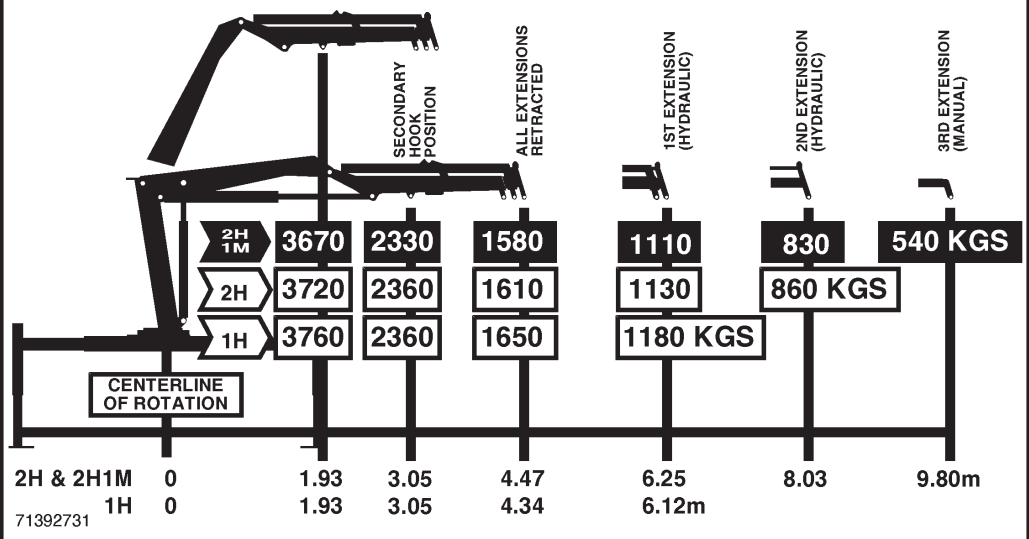
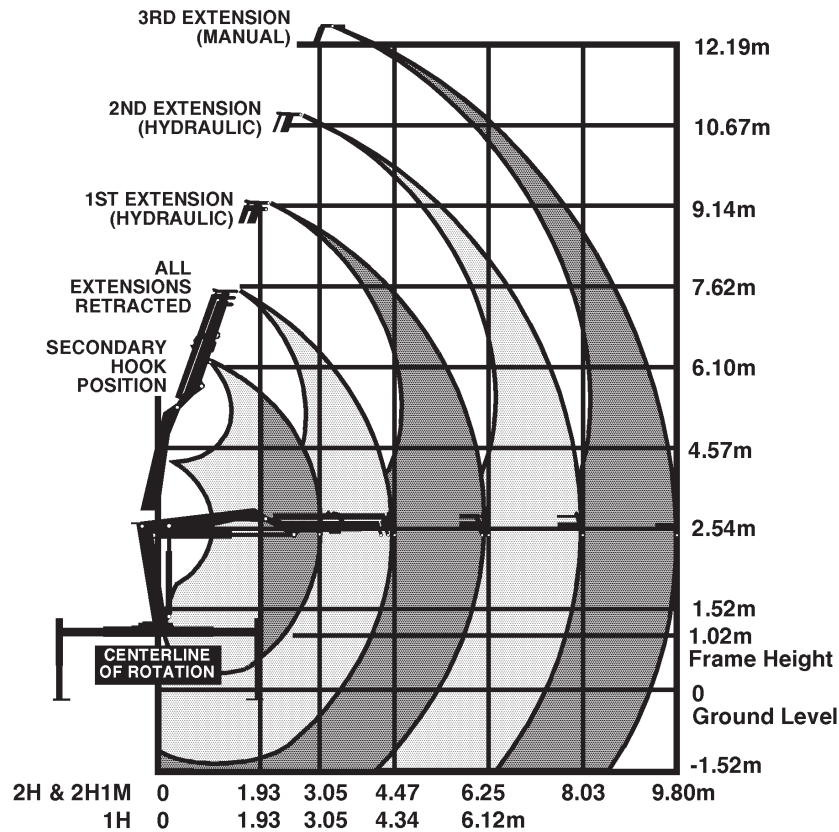

CAPACITY CHART-MODEL 780 CRANE

SECTION 2. 5200/780 CRANE REFERENCE

MAJOR CRANE ASSEMBLIES	3
WELDMENT PART NUMBER LOCATIONS	3
GREASE ZERK LOCATIONS & LUBRICANT REQUIREMENTS	4
RECOMMENDED SPARE PARTS LIST	5
RECOMMENDED SPARE PARTS LIST (CONT.)	6
INSTALLATION	7
CRANE MOUNTING	7
HYDRAULIC INSTALLATION	8
WINCH TROUBLESHOOTING	9

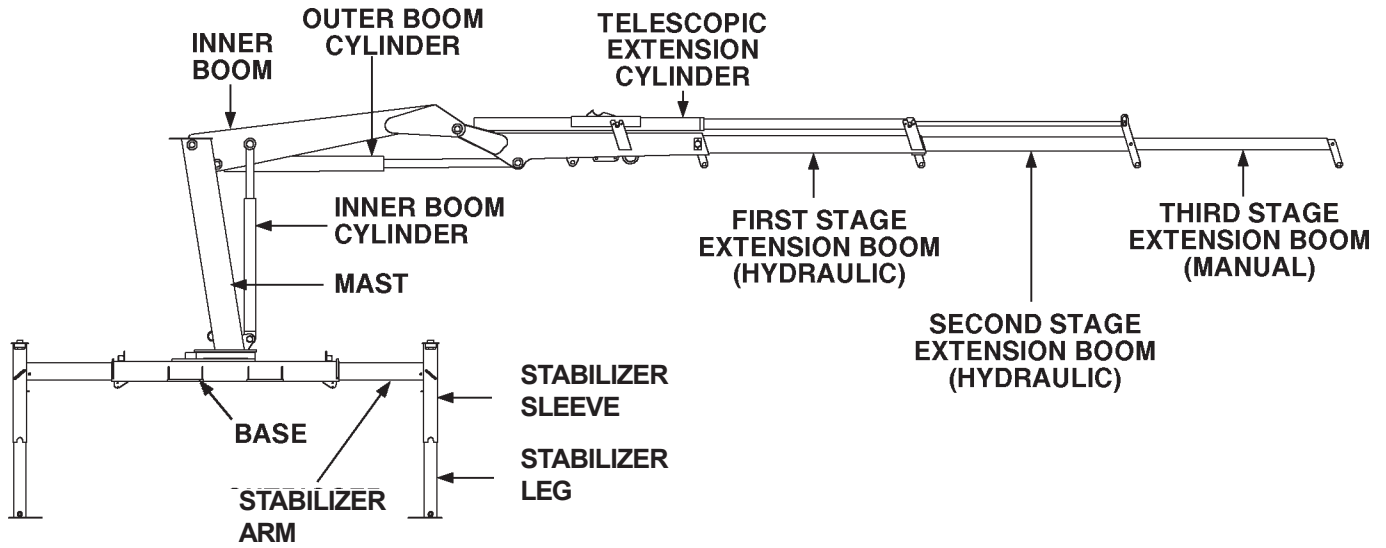

MAJOR CRANE ASSEMBLIES

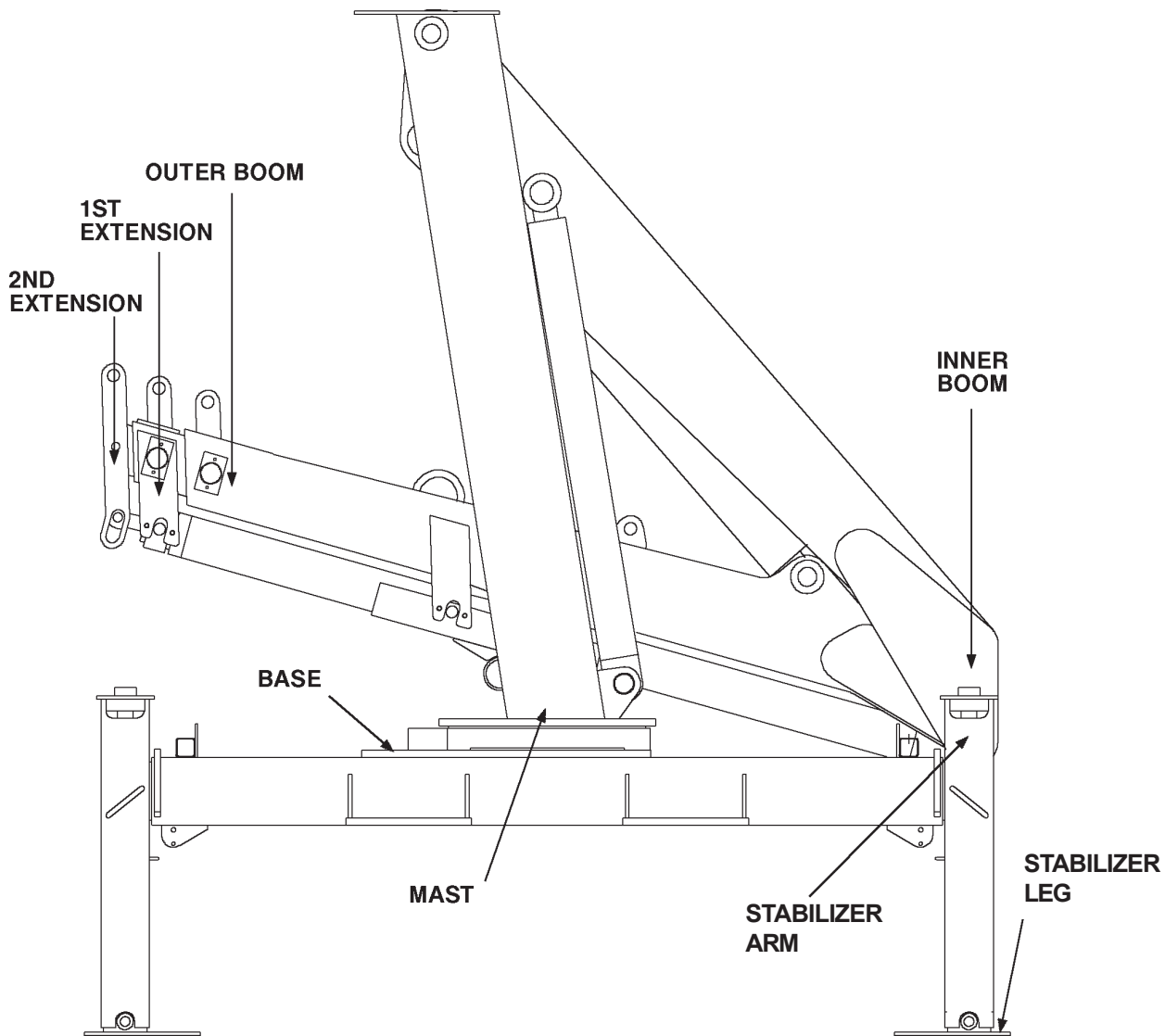

WELDMENT PART NUMBER LOCATIONS

GREASE ZERK LOCATIONS & LUBRICANT REQUIREMENTS

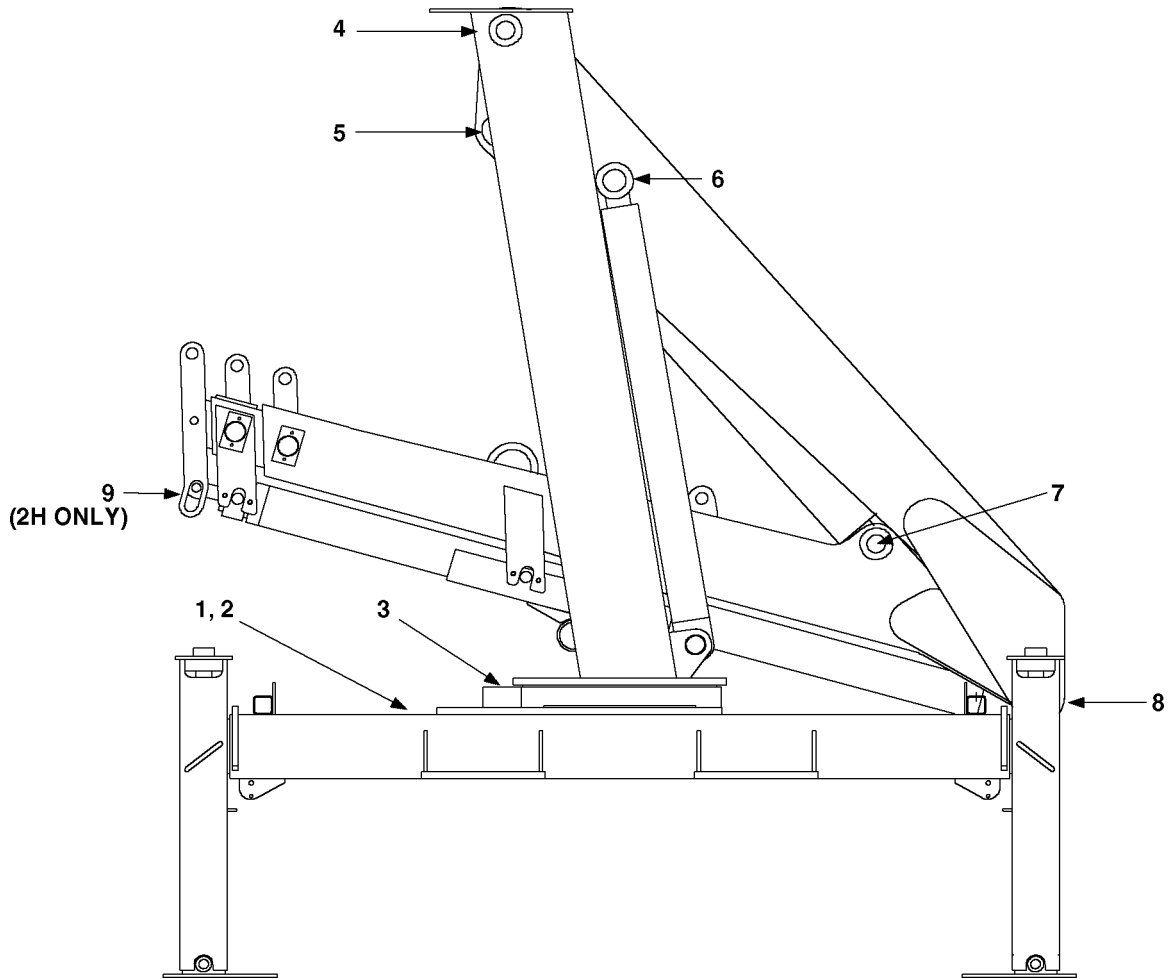

ITEM	LOCATION DESCRIPTION	LUBRICANT	FREQUENCY
1.	DRIVE GEAR GREASE EXTENSION	SHELL ALVANIA 2EP	WEEKLY
2.	TURNTABLE/BEARING GREASE EXTENSION *ROTATE CRANE WHILE GREASING		
3.	PINION GEAR	OR	
4.	MAST/INNER BOOM HINGE PIN	SHELL RETINAX "A"	
5.	OUTER CYLINDER BASE		
6.	INNER CYLINDER ROD		
7.	OUTER CYLINDER ROD		
8.	INNER/OUTER BOOM HINGE PIN		
9.	EXTENSION CYLINDER ROD (2H ONLY)		

NOTE: All application points must be greased weekly under normal work loads and moderate weather conditions. Under severe operating conditions, lubrication should be performed more frequently. See Volume 1; Operation, Maintenance and Repair for additional lubrication requirements.

RECOMMENDED SPARE PARTS LIST

1 YEAR SUPPLY 5200/780 CRANE FOR MANUAL: 99900922

This spare parts list does not necessarily indicate that the items can be expected to fail in the course of a year. It is intended to provide the user with a stock of parts sufficient to keep the unit operating with the minimal down-time waiting for parts. There may be parts failures not covered by this list. Parts not listed are considered as not being Critical or Normal Wear items during the first year of operations and you need to contact the distributor or manufacturer for availability.

ASSEMBLY DESIGNATION	ITEM NO.	PART NO.	DESCRIPTION	QTY	CODE	SHELF LIFE (MO)	ORDER QTY
41712219.01.20010308			BASE AND POWER DOWN/MANUAL OUT STABILIZER ASM				
	9	60020115	BUSHING	1	W		
	10	60020116	BUSHING	1	W		
	11	60020187	BUSHING	1	W		
	12	60020188	BUSHING	1	W		
	22	60030053	ROLLER	2	W		
	30	71056265	PINION GEAR	1	C		
3B221850.01.19961125			POWER DOWN STABILIZER CYLINDER				
	3	6I025087	PISTON	1	W		
	4	6H025015	HEAD	1	W		
	5	73054004	WEAR PAD	2	C		
	9	9B101214	SEAL KIT	2	W		
41710870.01.19961125			MAST ASM				
	2	7BF81520	BUSHING	2	W		
41710920.01.19961125			INNER BOOM ASM				
	4	7BF81220	BUSHING	12	W		
3B270000.01.20001102			INNER BOOM CYLINDER				
	3	6I035125	PISTON	1	W		
	4	6H035025	HEAD	1	W		
	5	9C142020	SEAL KIT	2	W		
	16	73054887	C'BAL VALVE	2	C		
	20	7BF81020	BUSHING	8	W		
41710914.01.19961125			OUTER BOOM ASM				
	5	7BF81220	BUSHING	4	W		
	9	60030175	WEAR PAD	1	W		
	10	60030060	WEAR PAD	2	W		
3C180920.01.19961125			OUTER BOOM CYLINDER				
	3	6I045143	PISTON	1	W		
	4	6H045030	HEAD	1	W		
	5	9C182423	SEAL KIT	1	W		
	15	73054242	VALVE 25GPM	2	C		
	19	7BF81220	BUSHING	2	W		
	20	7BF81520	BUSHING	2	W		
41710943.01.19961125			EXTENSION BOOM ASM - 1 HYDRAULIC				
	3	60030238	WEAR PAD-BEVELED	1	W		
3B200920.01.19961125			EXTENSION BOOM CYLINDER - 1H				
	3	6I302125	PISTON	1	W		
	4	6H030020	HEAD	1	W		
	5	73054242	COUNTERBALANCE VALVE	2	C		
	7	9C156920	SEAL KIT	1	W		
41710939.01.19961125			EXTENSION BOOM ASM - 2 HYDRAULIC				
	16	60030173	WEAR PAD	1	W		
	17	60030172	WEAR PAD	1	W		
	18	60030174	WEAR PAD	1	W		
	22	60030060	WEAR PAD	2	W		
41710940.01.19961125			EXTENSION BOOM ASM - 2 HYD/1 MNL				
	16	60030173	WEAR PAD	1	W		
	17	60030172	WEAR PAD	1	W		
	18	60030174	WEAR PAD	1	W		
	22	60030060	WEAR PAD	2	W		
3K185920.01.19970721			EXTENSION BOOM CYLINDER - 2H				
	5	6I095850	PISTON	1	W		
	6	6I025087	PISTON	1	W		
	7	6H271511	HEAD	1	W		
	8	6H112820	HEAD	1	W		
	11	73054242	VALVE	2	C		
	12	9X095850	SEAL KIT	1	W		

(CONTINUED)

RECOMMENDED SPARE PARTS LIST (CONT.)

ASSEMBLY DESIGNATION	ITEM NO.	PART NO.	DESCRIPTION	QTY	CODE	SHELF LIFE (MO)	ORDER QTY
70732573.01.19980721	RESERVOIR ASM						
	10	70144326	STRAINER	1	P		
	18	70034410	DIFFUSER	1	P		
	19	70732793	SCREEN	1	P		
93704355.01.19980721	INSTALLATION KIT						
		73052006	ELEMENT 10MIC	6	P		
		70048149	ELEMENT 100 MESH	6	P		
90716707.01.19961125	PROPORTIONAL REMOTE CONTROL KIT						
	5	73054876	FLOW VALVE	1	W		
	10	77041251	RELAY	2	W		
	11	77041237	SOLENOID 12V	1	W		
51713429.01.19961125	PROPORTIONAL REMOTE HANDLE ASM						
	16	77040371	TOGGLE SWITCH SPST	1	W		
	17	77040372	TOGGLE SWITCH SPDT	6	W		
	18	77040373	TOGGLE SWITCH SPST	2	W		
51713568.01.19961125	CABLE ASM-JIC BOX 94"						
	3	77041345	TOGGLE SWITCH ST	2	W		
	4	77041354	TOGGLE SWITCH DT	1	W		
	17	77041056	FUSE 20A IN-LINE	1	W		

INSTALLATION

GENERAL

This section contains specific instructions for the installation of your crane. Prior to installing the crane and hydraulic components, make sure the chassis is ready to receive the crane (refer to VOLUME 1, Installation).

CRANE MOUNTING

1. See SPECIFICATIONS in Section 1 for crane weight. Using an overhead hoist and fabric slings of adequate capacity, lift the crane about a foot to see if the crane is adequately balanced. If not, lower hoist and adjust slings. Re-check balance and re-position crane until mounting surface is level.
2. Install the truck frame support so that the tie-down studs pass through the supports (See figure below). Cut the support to the inside dimensions of the truck frame. Allow about 1/6" (1.6mm) extra. Grind the end of the support to fit inside the frame channel. Use a hammer to drive it into position if necessary.

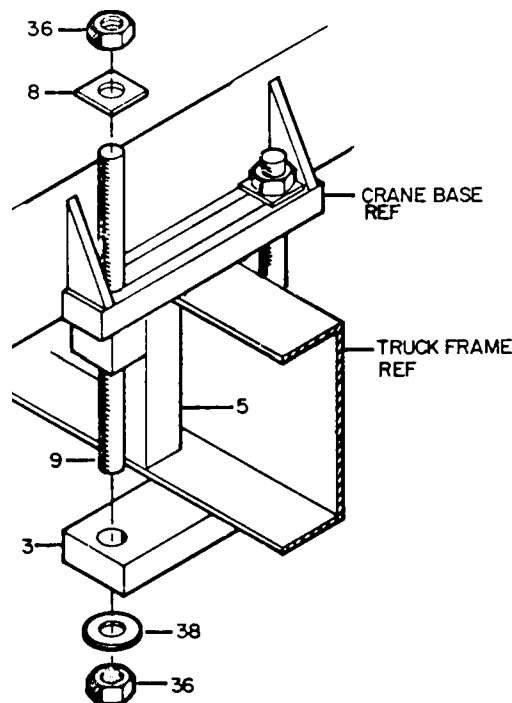

ITEM	DESCRIPTION	QTY
3.	CLAMP PLATE	4
5.	FRAME REINFORCEMENT BAR	4
8.	SQUARE WASHER	8
9.	TIE DOWN STUD	8
36.	LOCK NUT	16
38.	WASHER	8

CRANE INSTALLATION

3. Allow sufficient clearance between the cab and crane base, at least 5" (12.7cm). Position the crane on the chassis per the applicable installation drawing, centering the mounting slots over the truck frame rails. While holding crane with hoist, start mounting hardware per figure below. Note position of support weldments on truck frame. Hand tighten nuts. Observe underside of crane base. No clearance between base and frame bars is allowed.

4. Torque the 1"-8 UNC Grade 5 mounting hardware to 442 ft-lbs (62 kg-m). When torquing the mounting hardware the following precautions must be followed:

- A. Never use lock washers.
- B. Hardened washers must be used, and under the turning element, whether the turning element is the nut or the head of the bolt.
- C. Torque values specified are with residual oils or without special lubricants applied to the threads. If special lubricants are used, such as Never-Seize compound graphite and oil, molybdenum disulphite colloidal copper or white lead, reduce torque values 10%. Torque values for threaded fasteners are not affected with the use of Loctite.
- D. Do not use rusty fasteners, the rust will alter torque values significantly.
- E. Touch-up paint around mounting anchor plates.

CAUTION

DO NOT ATTEMPT TO APPLY THE SAME TORQUE TO THE TIE ROD AND SELF-LOCKING NUTS AS SHOWN IN THE TORQUE DATA CHART. DO NOT EXCEED 442 FT-LBS (62 KG-M). EXCEEDING THIS TORQUE VALUE COULD DAMAGE EITHER THE CHASSIS OR CRANE BASE.

POWER WRENCHING IS NOT RECOMMENDED UNTIL THE LEAD THREAD OF THE NUT INSERT IS ENGAGED BY HAND TURNING.

HYDRAULIC INSTALLATION

To install the hydraulic hoses, fittings, etc:

1. Install the hydraulic reservoir on the crane base.
2. Plumb the suction-line filter as shown in figure below.
3. Install the 1-1/4" suction hose between the suction-line filter and the pump inlet. Tighten the hose clamps.
4. Install the 1/2" pressure hoses between the pump outlet and the inlet port on the valvebank.
5. Install the return filter and gate valve on the reservoir. Install the hose between the valvebank and return filter.
6. Fill the hydraulic reservoir to the "FULL" mark.
7. Open the gate valve at the suction-line filter.
8. Open the return gate valve.
9. Start the vehicle's engine and engage the PTO. Allow the system to run for about five minutes and then check the vacuum gauge on the suction-line filter (it should read 8" mercury or less). If the vacuum reading is too high, check to make certain that the gate valve is opened completely. If the valve is fully opened, check for a collapsed or restricted suction line.
10. Cycle all hydraulic functions. Check for leaks, and refill the reservoir if necessary.

CAUTION

FAILURE TO OPEN THE GATE VALVE WILL RESULT IN A DRY RUNNING PUMP WHICH MAY DAMAGE THE PUMP.

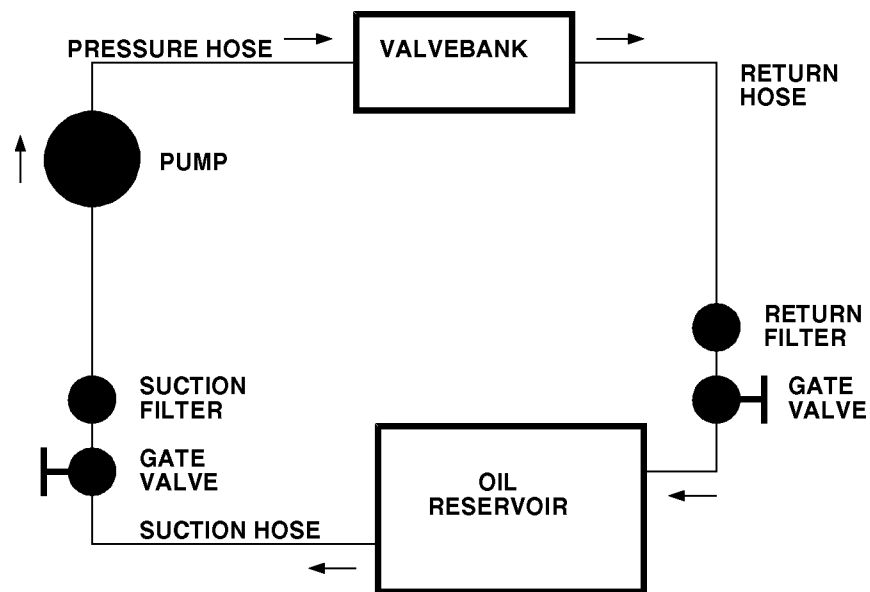

HYDRAULIC INSTALLATION

WINCH TROUBLESHOOTING

POSSIBLE CAUSE	PROBABLE CURE
WINCH WON'T LIFT HEAVY LOADS	
TOO MUCH LOAD	RIG TO REDUCE LOADING ON WINCH
LOW OR NO GEARBOX OIL	CHECK OIL LEVEL AND ADD PROPER OIL IF NECESSARY
MOTOR INLET PRESSURE LESS THAN SPECIFICATIONS WITH LOAD STALLED	TEST HYDRAULIC PUMP
MOTOR OUTLET PRESSURE TOO HIGH WITH LOAD STALLED	FIND AND REMOVE SOURCE OF RESTRICTION
BRAKE SHOULD ENGAGE IN PAYOUT DIRECTION ONLY	RUN WINCH WITH NO LOAD IN BOTH DIRECTIONS. SYSTEM PRESSURE SHOULD BE SLIGHTLY HIGHER IN PAYOUT DIRECTION.
CHECK FLOW TO WINCH MOTOR WITH WINCH UNDER LOAD	TEST PUMP IF NOT TO SPECIFICATIONS
CHECK END PLAY IN WORM	IF GREATER THAN 0.030", INSPECT WORM BEARINGS FOR WEAR. REPLACE IF NECESSARY.
WINCH WON'T HOLD LOAD	
BRAKE MAY NEED ADJUSTMENT	TURN ADJUSTING SCREW CLOCKWISE 1/4 TURN AT A TIME AND TEST WINCH AGAIN
BRAKE DISKS MAY BE WORN	INSPECT AND REPLACE IF NECESSARY. ADJUST AND RETEST
CAM CLUTCH IN BRAKE MAY BE INSTALLED INCORRECTLY	REVERSE CLUTCH AND RETEST
JOURNAL ON WORM WHERE CAM CLUTCH RUNS MAY BE GALLED OR WORN	INSPECT AND REPLACE WORM IF NECESSARY
WINCH RUNS TOO SLOW	
SYSTEM MAY HAVE LOW FLOW	INSTALL FLOW METER IN SYSTEM AND TEST UNDER LOAD. IF FLOW IS BELOW SPECIFICATIONS, INSPECT PUMP.
MOTOR WORN OUT	REPLACE MOTOR
WINCH WILL NOT RUN UNDER NO LOAD (RELIEF VALVE OPENS WITHOUT WINCH TURNING)	
MOTOR SEIZED UP	REMOVE MOTOR FROM WINCH AND TEST IF OPERABLE. IF NOT, REPLACE MOTOR.
WORM AND GEAR SET DAMAGED	REPAIR GEARBOX

See Section 3 for parts drawing.

SECTION 3. REPLACEMENT PARTS 5200/780 CRANE

PARTS INFORMATION	3
STD BASE & MNL OUT STABILIZER ASM (41712219-1)	4
STD BASE & MNL OUT STABILIZER ASM (41712219-2)	5
PWR DN STABILIZER CYL-STD (3B221850)	6
OPTION-PWR OUT STABILIZER KIT (31712253)	7
OPTION-PWR OUT STABILIZER CYL (3B220850)	8
MAST ASM (41710870)	9
INNER BOOM ASM (41710920)	10
INNER BOOM CYL (3B270000)	11
OUTER BOOM ASM (41710914)	12
OUTER BOOM CYLINDER (3C180920)	13
EXT BOOM ASM-1H (41710943)	14
EXT BOOM CYLINDER-1H (3B200920)	15
EXT BOOM ASM-2H (41710939)	16
EXT BOOM ASM-2H1M (41710940)	17
EXT BOOM CYLINDER-2H (3K185920)	18
BASE & PWR OUT STABILIZER ASM (41712220-1)	19
BASE & PWR OUT STABILIZER ASM (41712220-2)	20
RESERVOIR ASM (70732573)	21
INSTALLATION KIT (93704355)	22
DECAL KIT-5200 SERIES CRANE (95712260-1)	23
DECAL KIT-5200 SERIES CRANE (95712260-2)	24
HYDRAULIC KIT (91710962)	25
SELECTOR VALVE-HYDRAULIC SCHEMATIC (31717782)	26
HYDRAULIC OVERLOAD KIT (51717127)	27
VB ASM-8 SECT/MNL (51710944)	28
VALVEBANK (70731499)	28
VB ASM 4R/4M (51711707)	29
VALVEBANK (70732848)	29
VB ASM 5R/3M (51711706)	30
VALVEBANK (70732847)	30
VB ASM 6R/2M (51711708)	31
VALVEBANK (70732849)	31
CONTROL KIT 6F MNL (90704417)	32
PROP'L RMT CONTROL KIT (90716707)	33
PROP'L RMT HANDLE ASM (51713429)	35
TETHERED PROPORTIONAL REMOTE POTENTIOMETER ADJUSTMENT	35
CABLE ASM-JIC BOX 94" (51713568)	36
OPTION-DBL HOSE REEL KIT (31712113)	37
OPTION-WINCH KIT (31717776)	38
OPTION-WINCH KIT (31717776)	39
OPTION-CABLE & HOOK KIT (31705637)	40
TWO-BLOCK DAMAGE PREVENTION KIT (51724350 / DWG 99905344)	41

CAPACITY ALERT KIT - 3100 (31713333)	43
OPTION-AUGER MTG KIT (51707059)	44
OPTION -AUGER HOSE REEL KIT-V20 (51707805)	45
OPTION-AUX RESERVOIR-30GAL (31701760)	46
OPTION-SGL HOSE REEL KIT (31712487)	47
OPTION - LIGHT KIT (31717218)	48
DECAL KIT-MODEL 780 CRANE (95711801-1)	49
DECAL KIT-MODEL 780 CRANE (95711801-2)	50
RADIO REMOTE RETROFIT KIT (99903330-1)	51
ELEC. SCHEMATIC - RADIO REMOTE RETROFIT (99903330-2)	52
CABLE ASM-18GA/24 WIREX115 (51714624)	53
JIC BOX ASM-RADIO REMOTE (51717059)	54
RADIO REMOTE KIT (73733600-1)	55
RADIO REMOTE KIT (73733600-2)	56

PARTS INFORMATION

GENERAL

This section contains the exploded parts drawings and accompanying parts lists for the assemblies used on this crane. These drawings are intended to be used in conjunction with the instructions found in the REPAIR section in Volume 1. For optional equipment such as winches and remote controls, refer to the appropriate service manual.

WARNING

DO NOT ATTEMPT TO REPAIR ANY COMPONENT WITHOUT READING THE INFORMATION CONTAINED IN THE REPAIR SECTION IN VOLUME 1. PAY PARTICULAR ATTENTION TO STATEMENTS MARKED WARNING, CAUTION, OR NOTE IN THAT SECTION. FAILURE TO COMPLY WITH THESE INSTRUCTIONS MAY RESULT IN DAMAGE TO THE EQUIPMENT, PERSONAL INJURY, OR DEATH.

CRANE IDENTIFICATION

Every IMT crane has an identification placard (see figure) attached to the mast. When ordering parts, communicating warranty information, or referring to the unit in correspondence, always include the serial number and model numbers. All inquiries should be addressed to:

Iowa Mold Tooling Co., Inc.
Box 189, Garner, IA 50438-0189
Telephone: 641-923-3711
Product Support Fax: 641-923-2424

		IOWA MOLD TOOLING CO., INC. BOX 189, GARNER, IA 50438-0189	
MODEL NUMBER			
SERIAL NUMBER			
MFG DATE			
			70029119

SERIAL NUMBER PLACARD

CYLINDER IDENTIFICATION

To insure proper replacement parts are received, it is necessary to specify the complete number/letter sequence for any part requested. Part numbers may be cross checked by comparing the stamped identification on the cylinder case (See figure below) against the information contained in the service manual. You must include the part number stamped on the cylinder case when ordering parts.

WELDMENT IDENTIFICATION

Each of the major weldments - base, mast, inner boom, outer boom, extension boom and stabilizer weldments bear a stamped part number. Any time a major weldment is replaced, you must specify the complete part number as stamped on the weldment. The locations of the part numbers are shown in figure below.

ORDERING REPAIR PARTS

When ordering replacement parts:

1. Give the model number of the unit.
2. Give the serial number of the unit.
3. Specify the complete part number. When ordering cylinder parts, or one of the main weldments, always give the stamped part number.
4. Give a complete description of the part.
5. Specify the quantity required.

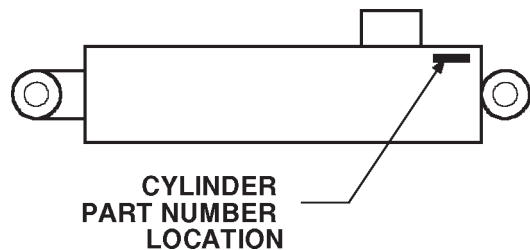

CYLINDER PART NUMBER LOCATION

**STD BASE & MNL OUT STABILIZER ASM
(41712219-1)**

CONTINUED ON FOLLOWING PAGE

ITEM	PART NO.	DESCRIPTION	QTY
1.	3B221850	POWER DOWN CYLINDER	2
2.	99903611	INSTRUCTIONS, HYD SHUTDN	1REF
3.	70732573	RESERVOIRASM	1
5.	71145016	STOP BLOCK	1
7.	52070138	"T" PIN	2
8.	52712217	BASE (INCL. 9-13)	1
9.	60020115	BUSHING (PART OF 8)	1REF
10.	60020116	BUSHING (PART OF 8)	1REF
11.	60020187	BUSHING (PART OF 8)	1REF
12.	60020188	BUSHING (PART OF 8)	1REF
13.	71056011	DRIVE GEAR (PART OF 8)	1REF
14.	52712252	ARM	2
15.	52705871	LEG	2
16.	53000714	GREASE EXTENSION	1
17.	53000717	GREASE EXTENSION	1
18.	60107648	HOSE CLAMP	2
19.	60010235	PINION COVER	1
20.	60010351	SPRING	2
21.	60010844	GREASE PLATE	1
22.	60030053	ROLLER	4
23.	60102767	ACCESS COVER	1
24.	60106032	STUD 1/2-13 X 2	2
25.	60106314	PIN	4
26.	60106886	PINION SPACER	1
27.	60106968	PIN	2
28.	60102769	GEAR GUARD-INTERMEDIATE	1
29.	71056264	INTERMEDIATE GEAR	1
30.	71056265	PINION GEAR	1
31.	71056627	TURNTABLE GEAR-BEARING	1
33.	72053301	COUPLING 1/8NPT	2
34.	72053508	ZERK, GREASE, 1/8 NPT	3
35.	72060002	CAP SCR 1/4-20 X 3/4 HH GR5	2

36.	72060054	CAP SCR 3/8-16 X 3 HH GR5	2
37.	72060092	CAP SCR 1/2-13 X 1-1/4 HH GR5	2
38.	72060102	CAP SCR 1/2-13 X 5-1/2 HH GR5	4
39.	72060833	CAP SCR 5/16 X 3/4 HH SLFTPG	2
40.	72062080	NUT 1/2-13 LOCK	2
41.	72062103	NUT 3/8-16 LOCK	8
42.	72062107	NUT 1/2-13 CTR LOCK	4
43.	72063002	WASHER 5/16 WRT	2
44.	72053281	STRT ELBOW 1/8 NPT 90o	1
45.	72063027	MACH BUSHING 5/8 X 14GA	2
46.	72063039	MACH BUSHING 2 X 10GA	1
47.	72063049	WASHER 1/4 LOCK	2
48.	72063053	WASHER 1/2 LOCK	2
49.	72063116	WASHER 3/4 FLAT HARD	20
50.	72066095	RETAINING RING 2" EXT	1
51.	72066178	COTTER PIN 1/8 X 1	8
52.	72060207	CAP SCR 3/4-10 X 3 HH GR8	20
53.	73540004	HYD MOTOR (FROM 5-15-98)	1
	73051004	HYD MOTOR (TO 5-15-98)	1
	73054538	C'BALANCE VALVE (TO 5-15-98)	2
	72060738	CAP SCR (TO 5-15-98)	4
	5V151830	MOTOR BLOCK (TO 5-15-98)	1
	7Q072112	O-RING (TO 5-15-98)	2
55.	72066125	RETAINING RING 1" EXT HD	4
56.	72066185	COTTER PIN	2
58.	72060046	CAP SCR 3/8-16 X 1 HH GR5	4
59.	72063003	WASHER 3/8 WRT	10
60.	60108883	CHAIN	2
61.	70058060	LINK, COLD SHUT	2
62.	89393036	SLEEVE	5'
64.	72531826	RED. BUSHING 1/4 X 1/8 NPT	1
65.	72060023	CAP SCR 5/16-18 X 3/4 HH GR5	2
66.	72063050	WASHER 5/16 LOCK	2
67.	60119748	GUARD-CTRL HANDLE	2
68.	72060006	CAP SCR 1/4-20X1-1/2 HHGR5	8
69.	72063001	WASHER 1/4 WRT	16
70.	72062104	NUT 1/4-20 LOCK	8

NOTE

INSTALL 70399271 - DECAL-FULLY DEPLOYED - ONTOP OF STABILIZER BEAMS WHEN BEAMS ARE FULLY EXTENDED. DECAL MUST BE VISIBLE.

STD BASE & MNL OUT STABILIZER ASM (41712219-2)

WARNING

ANYTIME A GEAR-BEARING BOLT IS REMOVED, IT MUST BE REPLACED WITH A NEW BOLT OF THE IDENTICAL GRADE AND SIZE. FAILURE TO REPLACE GEAR-BEARING BOLTS MAY RESULT IN BOLT FAILURE DUE TO METAL FATIGUE, CAUSING SERIOUS INJURY OR DEATH.

CAUTION

BEFORE TIGHTENING TURNTABLE BEARING BOLTS, REFER TO THE TURNTABLE BEARING FASTENER TIGHTENING SEQUENCE AND TORQUE DATA CHART IN THE REFERENCE SECTION.

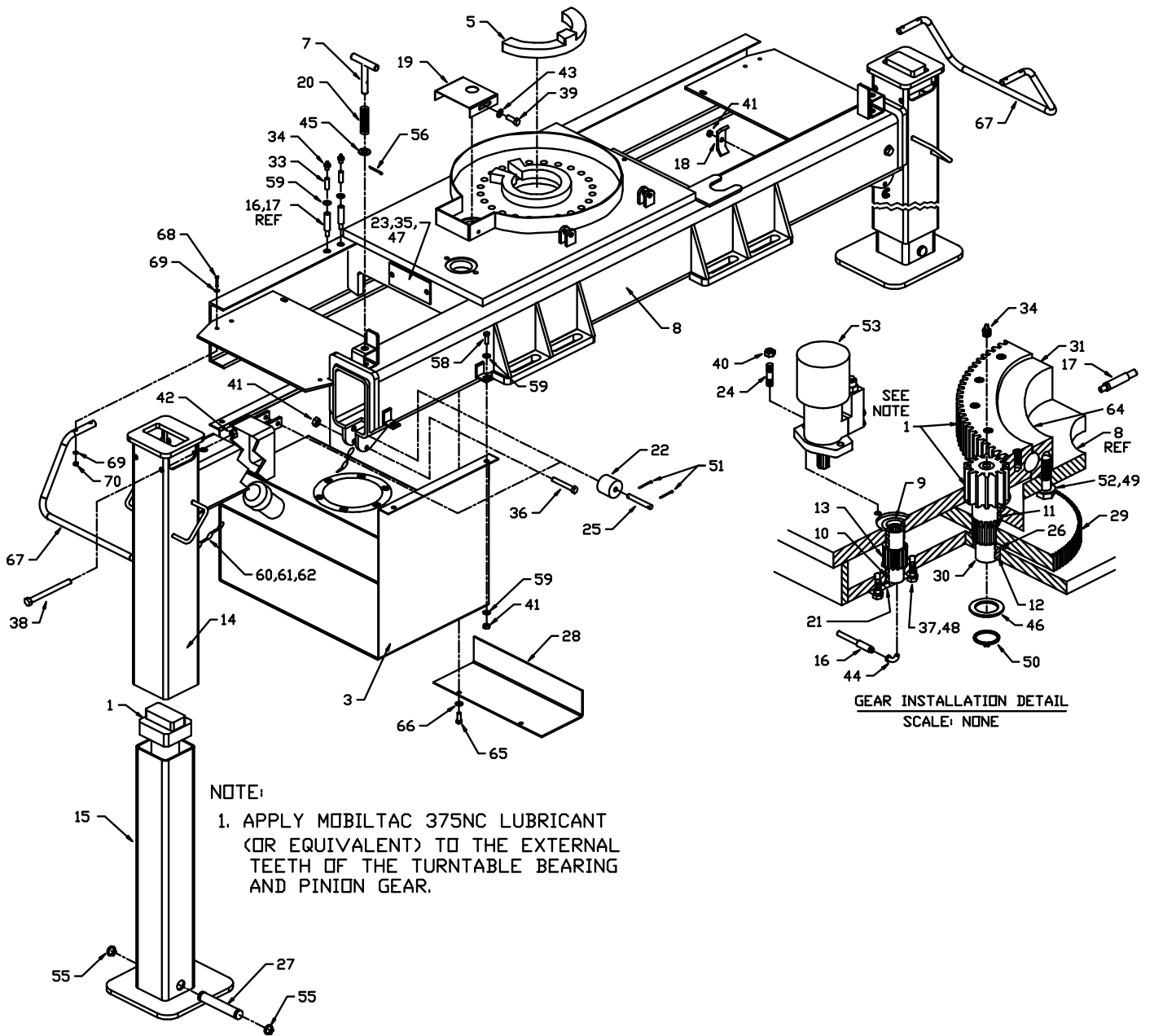

**PWR DN STABILIZER CYL-STD
(3B221850)**

ITEM	PART NO	DESCRIPTION	QTY
1.	4B221850	CASE (INCL:6)	1
2.	2G221850	ROD	1
3.	6I025087	PISTON	1
4.	6H025015	HEAD	1
5.	73054004	LOCKING/ HOLDING VALVE	1
6.	7PNPXT02	PLUG 1/8NPT (PART OF 1)	3REF
7.	6C150015	STOP TUBE	1
8.	72060708	CAP SCR 1/4-20 X 1 1/4 SH	6
9.	9B101214	SEAL KIT (INCL:10-18)	1
10.	7Q072137	O-RING (PART OF 9)	1REF
11.	7T66P025	SEAL, PISTON (PART OF 9)	1REF
12.	7T61N087	LOCK RING SEAL (PART OF 9)	1REF
13.	7T2N8015	WEAR RING (PART OF 9)	1REF
14.	60138272	STOP TUBE (PART OF 9) (WAS 6A025015)	1REF
15.	7Q072228	O-RING (PART OF 9)	1REF
16.	7Q10P228	BACK-UP RING (PART OF 9)	1REF
17.	7R546015	ROD SEAL (PART OF 9)	1REF
18.	7R14P015	ROD WIPER (PART OF 9)	1REF
19.	60125699	PIN-LOCK TUBE (PART OF 9)	1REF

NOTE

IT IS RECOMMENDED THAT ALL COMPONENTS OF THE SEAL KIT BE REPLACED WHENEVER THE CYLINDER IS DISASSEMBLED. THIS WILL REDUCE FUTURE DOWNTIME.

APPLY "LUBRIPLATE #630-2" MEDIUM HEAVY, MULTI-PURPOSE LUBRICANT OR EQUIVALENT TO ALL PISTON, HEAD GLAND, AND HOLDING VALVE SEALS, NYLON LOCK RING, CAST IRON PISTON RINGS, AND ROD STINGER THREADS.

APPLY "NEVER-SEEZ" REGULAR GRADE ANTI-SEIZE AND LUBRICATING COMPOUND TO CYLINDER HEAD AND CASE THREADS.

SAE #6 O-RING PORTS

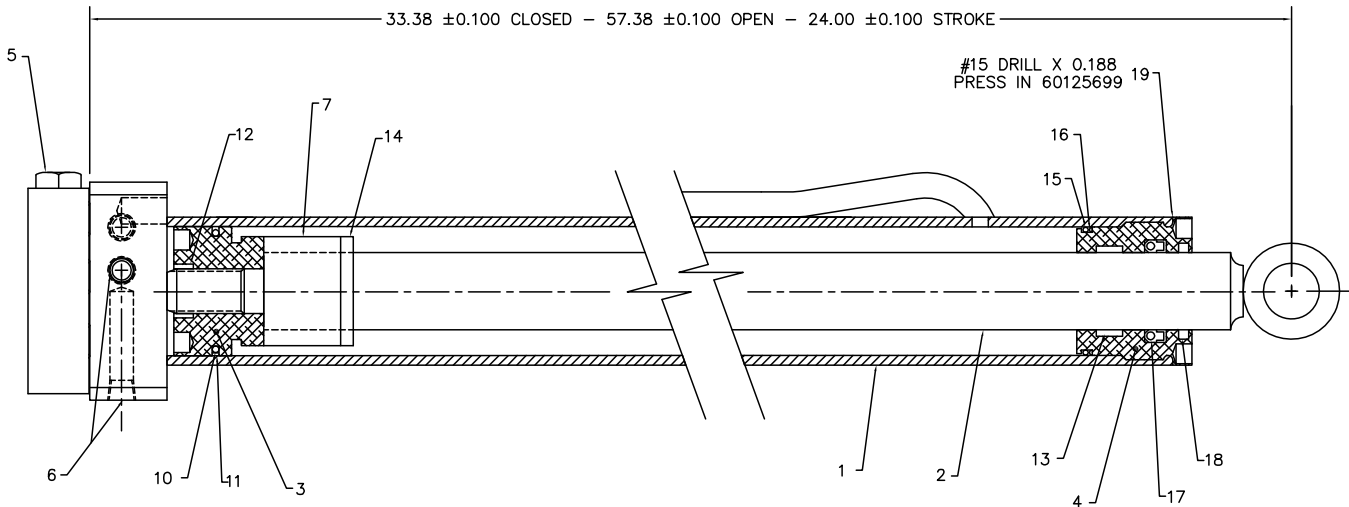
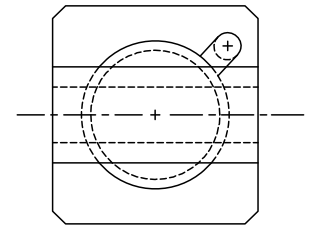
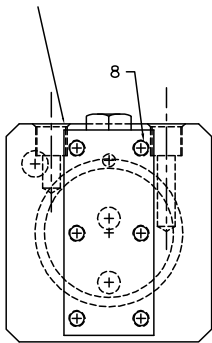

**OPTION-PWR OUT STABILIZER KIT
(31712253)**

ITEM	PART	DESCRIPTION	QTY
1.	3B220850	POWER OUT CYLINDER	2
2.	51703590	HOSE ASSEMBLY 1/4X23	2
3.	51704280	HOSE ASSEMBLY 1/4X40	4
4.	70029451	CONTROL HANDLE	2
6.	72053758	ELBOW 7/16MSTR 7/16MJIC 90°	4
7.	71039096	KNOB	2
8.	72060928	CAP SCR 1/2-13X2-1/4 HHGR5	4
9.	72062080	NUT1/2-13 LOCK	4

10.	72532707	ADAPTER #4MJIC #6FJIC	2
11.	72532768	TEE 7/16MJIC	2
12.	72066168	COTTER PIN	2
13.	72066338	CLEVIS PIN	2
15.	52704745	CONTROL ROD - MALE	2
16.	72066336	COTTER PIN	1
17.	72066337	PIN	1
18.	52704744	CONTROL ROD - FEMALE	1
21.	71382277	DECAL- PWR OUT STAB	2
22.	70392864	DECAL - WARN STAB STD CLR	2
23.	70399271	DECAL-FULLY DEPLOYED	2

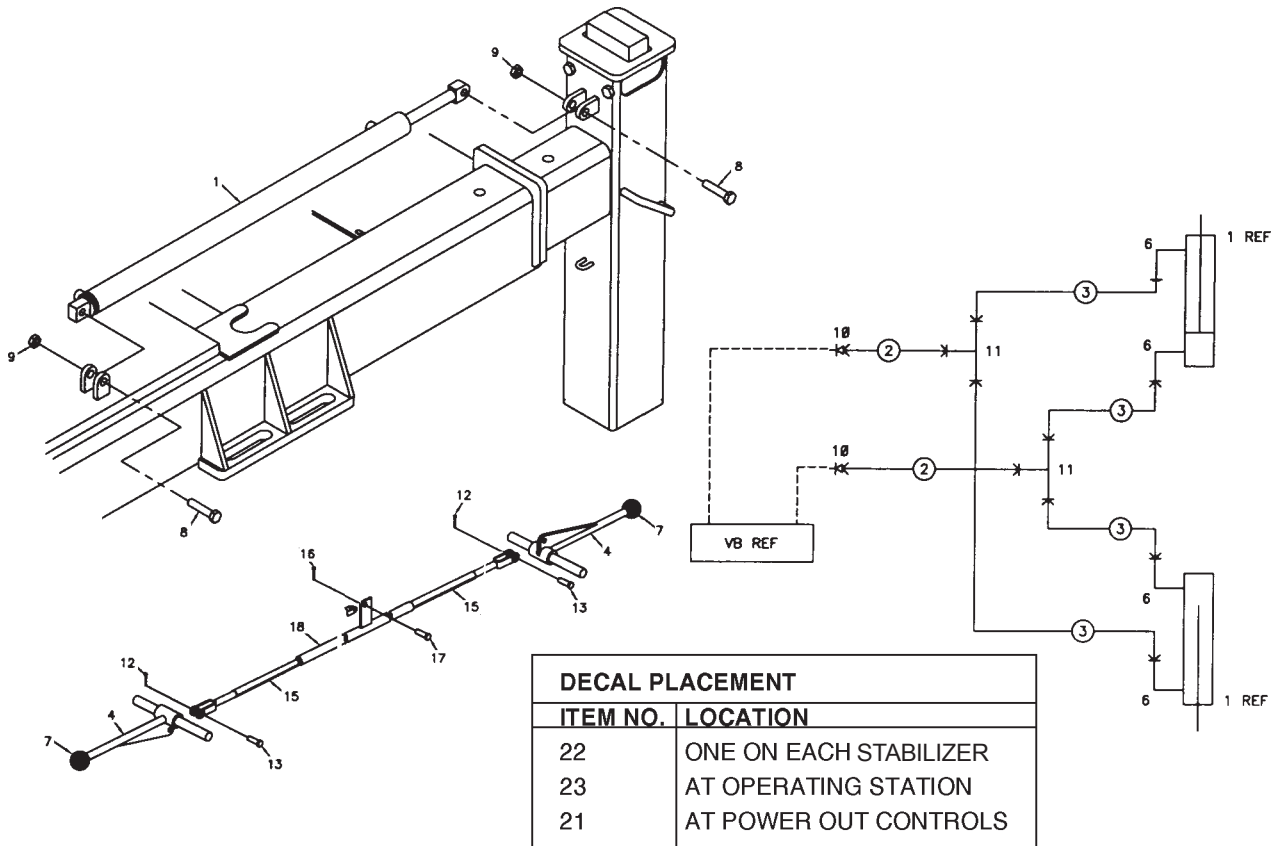

NOTE: INSTALL # 23, DECAL, AT FULL STAB EXTENSION

OPTION-PWR OUT STABILIZER CYL (3B220850)

1.	4B220850	CASE ASM	1
2.	4G220850	ROD ASM	1
3.	6C125007	STOP TUBE 1-1/4	1
4.	6H012007	HEAD	1
5.	6I012050	PISTON	1
6.	9B050608	SEAL KIT (INCL:7-12)	1
7.	7Q072021	O-RING (PART OF 6)	1REF
8.	7Q072214	O-RING (PART OF 6)	1REF
9.	7Q10P214	BACK-UP RING (PART OF 6)	1REF
10.	7R100750	U-CUP SEAL (PART OF 6)	1REF
11.	7R13P007	ROD WIPER (PART OF 6)	1REF
12.	7T66P012	PISTON SEAL (PART OF 6)	1REF
13.	72066029	RETAINING RING	1

NOTE

IT IS RECOMMENDED THAT ALL COMPONENTS OF THE SEAL KIT BE REPLACED WHENEVER THE CYLINDER IS DISASSEMBLED. THIS WILL REDUCE FUTURE DOWNTIME.

APPLY "LUBRIPLATE #630-2" MEDIUM HEAVY, MULTI-PURPOSE LUBRICANT OR EQUIVALENT TO ALL PISTON, HEAD GLAND, AND HOLDING VALVE SEALS, NYLON LOCK RING CAST IRON PISTON RINGS, AND ROD STINGER THREADS.

APPLY "NEVER-SEEZ" REGULAR GRADE ANTI-SEIZE AND LUBRICATING COMPOUND TO CYLINDER HEAD AND CASE THREADS.

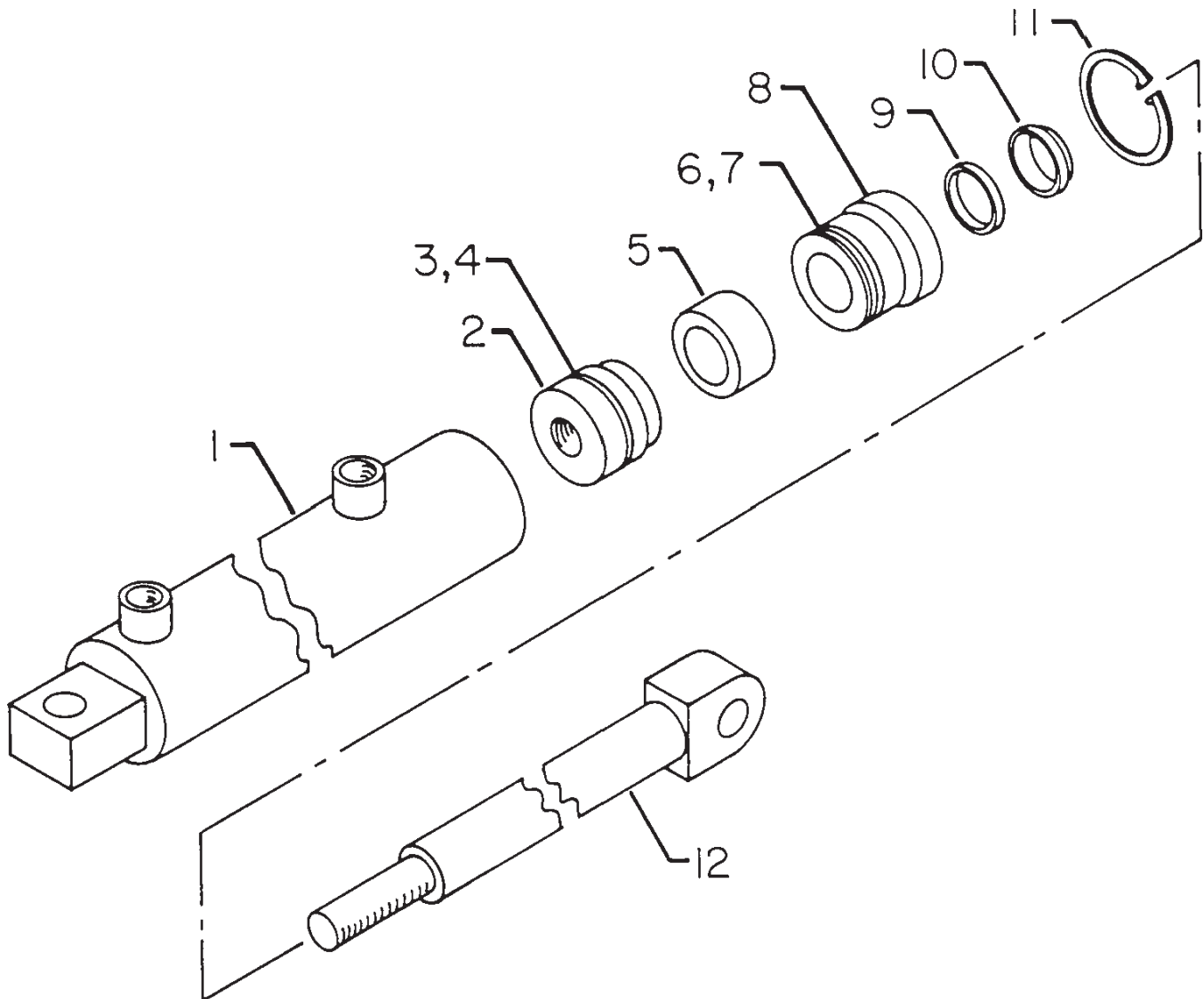

MAST ASM (41710870)

ITEM	PART NO.	DESCRIPTION	QTY
1.	52710871	MAST (INCL:2)	1
2.	7BF81520	BUSHING (PART OF 1)	2REF
3.	60010118	HOSE CLAMP	2
4.	60104539	PINION GEAR COVER	1
5.	70029119	SERIAL NO. PLACARD	1
6.	72060931	CAP SCR 5/8-11X2-3/4 HH GR8	18
7.	72062103	NUT 3/8-16 LOCK	2
8.	72063119	WASHER 5/8 FLAT HARD	18
9.	72066340	POP RIVET 1/8	2

WARNING

ANYTIME A GEAR-BEARING BOLT IS REMOVED, IT MUST BE REPLACED WITH A NEW BOLT OF THE IDENTICAL GRADE AND SIZE. FAILURE TO REPLACE GEAR-BEARING BOLTS MAY RESULT IN BOLT FAILURE DUE TO METAL FATIGUE, CAUSING SERIOUS INJURY OR DEATH.

CAUTION

BEFORE TIGHTENING TURNTABLE BEARING BOLTS, REFER TO THE TURNTABLE BEARING FASTENER TIGHTENING SEQUENCE AND TORQUE DATA CHART IN THE REFERENCE SECTION.

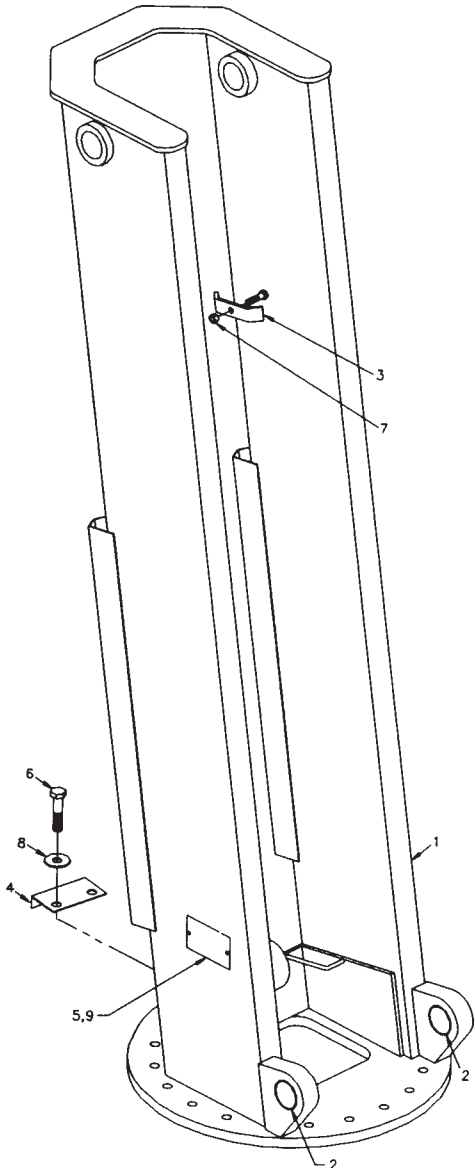

INNER BOOM CYL (3B270000)

1.	4B142920	CASE ASM (INCL: 20 & 21)	1
2.	4H142920	ROD ASM (INCL: 19 & 20)	1
3.	6I035125	PISTON	1
4.	6H035025	HEAD	1
5.	9C142020	SEAL KIT (INCL:6-15)	1
6.	7Q072338	O-RING (PART OF 5)	1REF
7.	7Q10P338	BACK-UP RING (PART OF 5)	1REF
8.	7T2N8027	WEAR RING (PART OF 5)	1REF
9.	7R546025	ROD SEAL (PART OF 5)	1REF
10.	7R14P025	ROD WIPER (PART OF 5)	1REF
11.	7Q072151	O-RING (PART OF 5)	1REF
12.	7T66P035	PISTON SEAL (PART OF 5)	1REF
13.	7T65I035	PISTON RING (PART OF 5)	2REF
14.	7T61N125	LOCK RING (PART OF 5)	1REF
15.	6A025025	WAFFER LOCK (PART OF 5)	1REF
16.	73054887	C'BAL VALVE	1
17.	6C150025	STOP TUBE	1
18.	6C300025	STOP TUBE	1
19.	72053507	ZERK 1/4-28(PART OF 2)	1REF
20.	7BF81020	BUSHING (PART OF 1 & 2)	4REF
21.	7PNPXT02	PLUG 1/8NPT (PART OF 1)	3REF

NOTE

IT IS RECOMMENDED THAT ALL COMPONENTS OF THE SEAL KIT BE REPLACED WHENEVER THE CYLINDER IS DISASSEMBLED. THIS WILL REDUCE FUTURE DOWNTIME.

APPLY "LUBRIPLATE #630-2" MEDIUM HEAVY, MULTI-PURPOSE LUBRICANT OR EQUIVALENT TO ALL PISTON, HEAD GLAND, AND HOLDING VALVE SEALS, NYLON LOCK RING CAST IRON PISTON RINGS, AND ROD STINGER THREADS.

APPLY "NEVER-SEEZ" REGULAR GRADE ANTI-SEIZE AND LUBRICATING COMPOUND TO CYLINDER HEAD AND CASE THREADS.

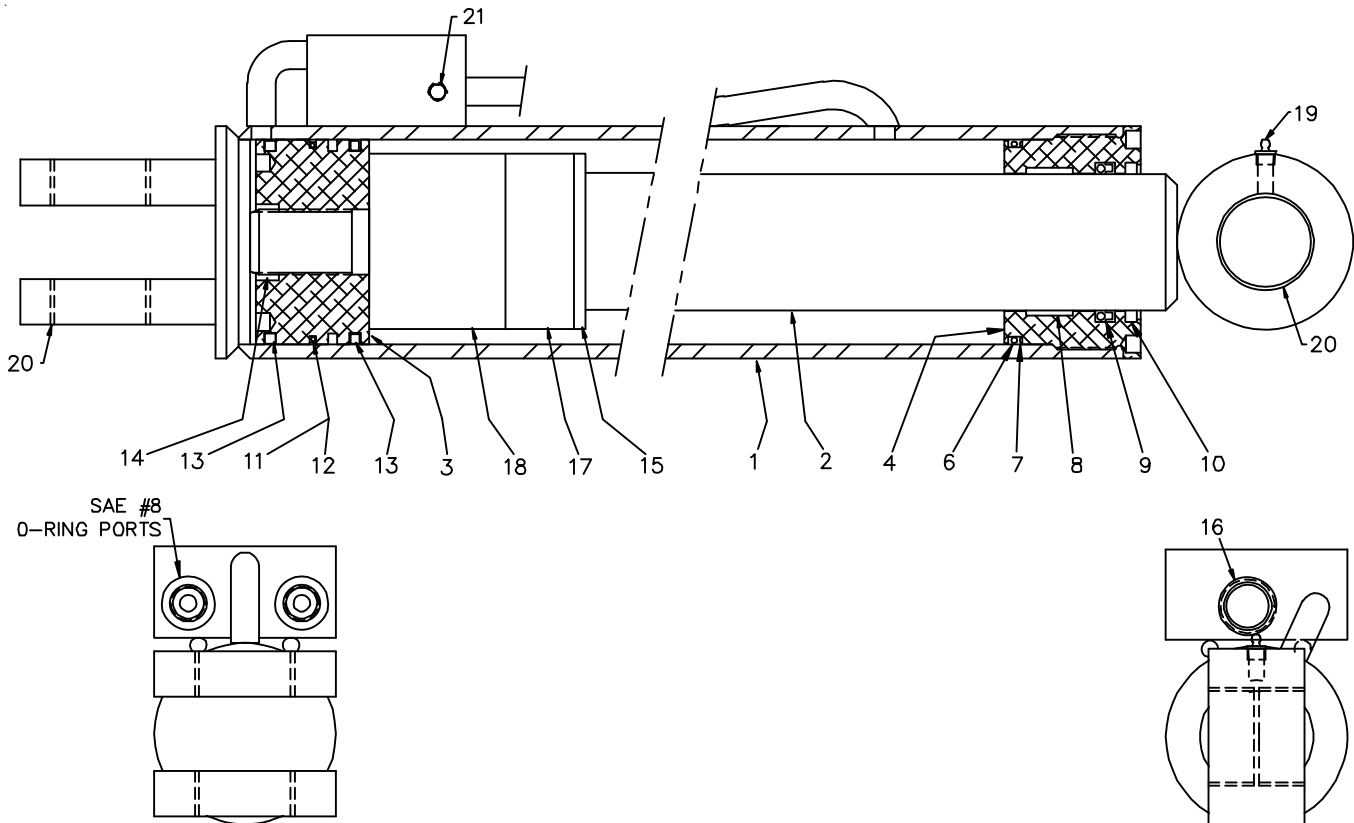

OUTER BOOM CYLINDER (3C180920)

ITEM	PART NO.	DESCRIPTION	QTY
1.	4C258870	CASE ASM (INCL:20-22)	1
2.	52718647	ROD (INCL:19,21) (WAS 4H180920)	1
3.	6I045143	PISTON	1
4.	6H045030	HEAD	1
5.	9C182423	SEAL KIT (INCL:6-14,18)	1
6.	7Q072345	O-RING (PART OF 5)	1REF
7.	7Q10P346	BACK-UP RING (PART OF 5)	1REF
8.	7T2N8032	ROD WEAR RING (PART OF 5)	1REF
9.	7R546030	U-CUP SEAL (PART OF 5)	1REF
10.	7R14P030	ROD WIPER (PART OF 5)	1REF
11.	7Q072155	O-RING (PART OF 5)	1REF
12.	7T66P045	PISTON SEAL (PART OF 5)	1REF
13.	7T65I045	PISTON RING (PART OF 5)	2REF
14.	7T61N143	LOCK RING (PART OF 5)	1REF
15.	73054242	VALVE 25GPM	2REF
16.	6C150030	STOP TUBE 1-1/2	1
17.	6C300030	STOP TUBE 3	1
18.	60138277	STOP TUBE (PART OF 5) (WAS 6A025030)	1REF
19.	7BF81220	BUSHING (PART OF 2)	2REF
20.	7BF81520	BUSHING (PART OF 1)	2REF
21.	72053507	ZERK 1/4-28 (PART OF 1 & 2)	2REF
22.	7PNPXT02	PLUG 1/8NPT (PART OF 1)	2REF
23.	60125699	PIN-LOCK TUBE	1

NOTE

IT IS RECOMMENDED THAT ALL COMPONENTS OF THE SEAL KIT BE REPLACED WHENEVER THE CYLINDER IS DISASSEMBLED. THIS WILL REDUCE FUTURE DOWNTIME.

APPLY "LUBRIPLATE #630-2" MEDIUM HEAVY, MULTI-PURPOSE LUBRICANT OR EQUIVALENT TO ALL PISTON, HEAD GLAND, AND HOLDING VALVE SEALS, NYLON LOCK RING, CAST IRON PISTON RINGS, AND ROD STINGER THREADS.

APPLY "NEVER-SEEZ" REGULAR GRADE ANTI-SEIZE AND LUBRICATING COMPOUND TO CYLINDER HEAD AND CASE THREADS.

ITEM #18, STOP TUBE, REPLACES 6A025030 WAFER LOCK. USE STOP TUBE INSTEAD OF WAFER LOCK WHEN RESEALING CYLINDER.

PRESS LOCKING PIN (ITEM #23) INTO #15 HOLE DRILLED 0.188" DEEP.

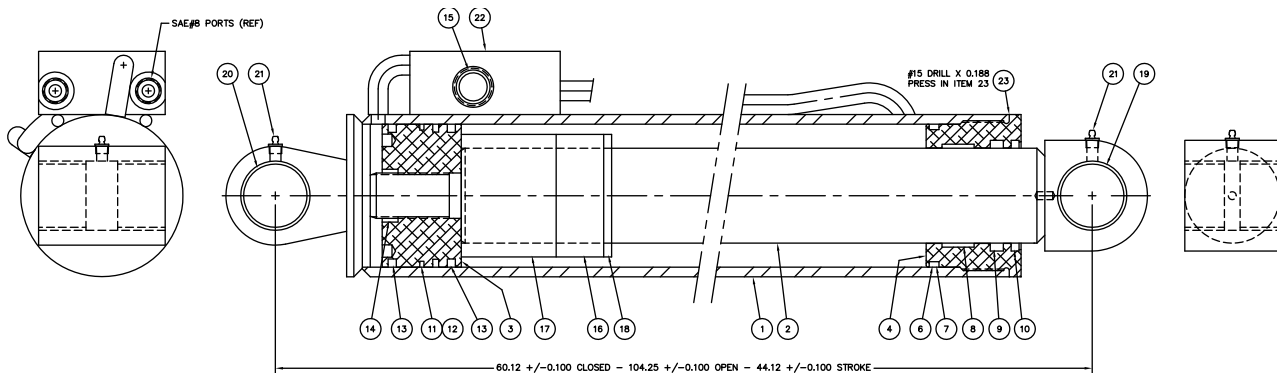

EXT BOOM ASM-1H (41710943)

ITEM	PART NO.	DESCRIPTION	QTY
1.	3B200920	EXTENSION CYLINDER-1H	1
2.	52710942	1ST STG EXTENSION BOOM	1
3.	60030238	WEAR PAD-BVLD	1
4.	52705801	PIN (PART OF 11)	1REF
5.	60108902	PIPE (PART OF 11)	1REF
6.	60107324	HOOK LINK (PART OF 11)	2REF
7.	60107324	SWIVEL HOOK 8-TON (PART OF 11) (WAS 60103575)	1REF

8.	72601666	CAP SCR 1 1/4-7X4 HH GR5 (PART OF 11)	1REF
9.	72062073	NUT 1 1/4-7 LOCK (PART OF 11)	1REF
10.	72066145	HAIR PIN 3/16 (PART OF 11)	1REF
11.	51706200	HOOK ASM (INCL:4-10)	1
12.	60107292	LOCK PLATE	4
13.	72060091	CAP SCR 1/2-13X1 HH GR5	8
14.	72063053	WASHER 1/2 LOCK	8

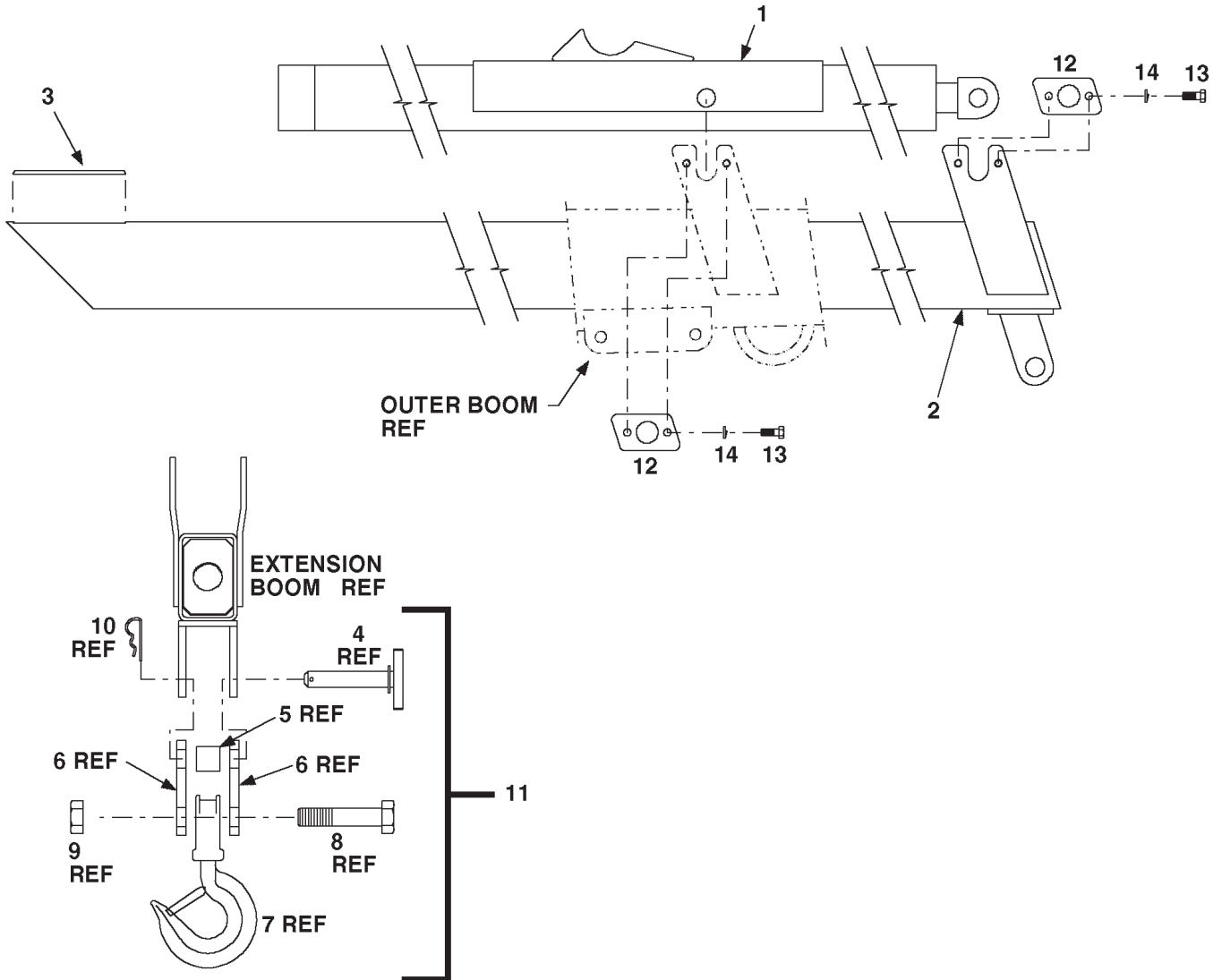

EXT BOOM CYLINDER-1H (3B200920)

ITEM	PART NO.	DESCRIPTION	QTY
1.	4B200920	CASE ASM (INCL: 18)	1
2.	4G200920	ROD ASM	1
3.	6I302125	PISTON	1
4.	6H030020	HEAD	1
5.	73054242	COUNTERBALANCE VALVE	2
6.	6C150020	STOP TUBE	2
7.	9C156920	SEAL KIT (INCL:8-17)	1
8.	6A025020	WAFER LOCK (PART OF 7)	1REF
9.	7T66P300	PISTON SEAL (PART OF 7)	1REF
10.	7T61N125	LOCK RING (PART OF 7)	1REF
11.	7T2N4030	WEAR RING (PART OF 7)	2REF
12.	7Q072124	O-RING (PART OF 7)	1REF
13.	7Q072334	O-RING (PART OF 7)	1REF
14.	7Q10P334	BACKUP RING (PART OF 7)	1REF
15.	7T2N4022	ROD WEAR RING (PART OF 7)	1REF
16.	7R546020	U-CUP SEAL (PART OF 7)	1REF
17.	7R14P020	ROD WIPER (PART OF 7)	1REF
18.	7PNPXT02	PLUG 1/8NPT (PART OF 1)	8REF

NOTE

IT IS RECOMMENDED THAT ALL COMPONENTS OF THE SEAL KIT BE REPLACED WHENEVER THE CYLINDER IS DISASSEMBLED. THIS WILL REDUCE FUTURE DOWNTIME.

APPLY "LUBRIPLATE #630-2" MEDIUM HEAVY, MULTI-PURPOSE LUBRICANT OR EQUIVALENT TO ALL PISTON, HEAD GLAND, AND HOLDING VALVE SEALS, NYLON LOCK RING, CAST IRON PISTON RINGS, AND ROD STINGER THREADS.

APPLY "NEVER-SEEZ" REGULAR GRADE ANTI-SEIZE AND LUBRICATING COMPOUND TO CYLINDER HEAD AND CASE THREADS.

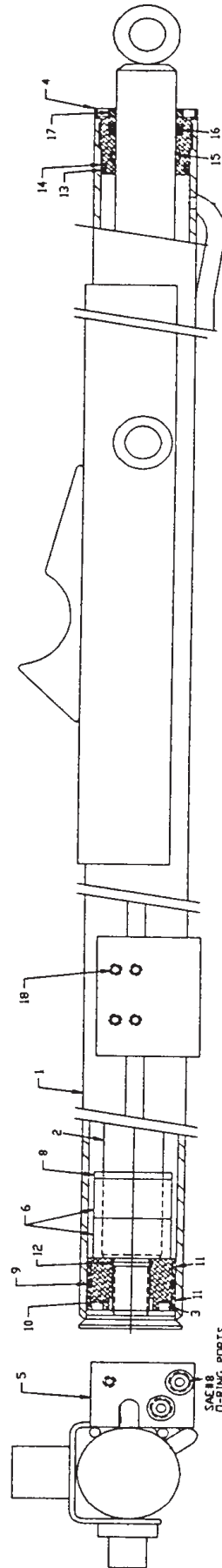

EXT BOOM ASM-2H (41710939)

ITEM	PART NO.	DESCRIPTION	QTY
1.	3K185920	TELESCOPIC CYLINDER	1
2.	51706200	HOOK ASM (INCL:3-9)	1
3.	52705801	PIN (PART OF 2)	1REF
4.	60108902	SPACER (PART OF 2)	1REF
5.	60107324	HOOK LINK (PART OF 2)	2REF
6.	72062073	NUT 1 1/4-7 LOCK (PART OF 2)	1REF
7.	70734177	SWVL HOOK 8TON (PART OF 2) (WAS 60103575)	1REF
8.	72601666	CAP SCR 1 1/4-7X4 HHGR5 (PART OF 2)	1REF
9.	72066145	HAIR PIN 3/16 (PART OF 2)	1REF
10.	52710941	1ST STG EXT BOOM	1

11.	52706708	2ND STG EXT BOOM	1
12.	60101906	PIN	1
13.	60107292	LOCK PLATE	4
14.	72060091	CAP SCR 1/2-13X1 HH GR5	8
15.	72063053	WASHER 1/2 LOCK	8
16.	60030173	WEAR PAD	1
17.	60030172	WEAR PAD	1
18.	60030174	WEAR PAD	1
19.	60020197	ROLLER	2
20.	72066125	RETAINING RING 1"	2
21.	72063010	WASHER 1 WRT	2
22.	60030060	WEAR PAD	2
23.	60107550	LOCK PLATE	2
24.	72063051	WASHER 3/8 LOCK	4
25.	72060044	CAP SCR 3/8-16X3/4 HH GR5	4

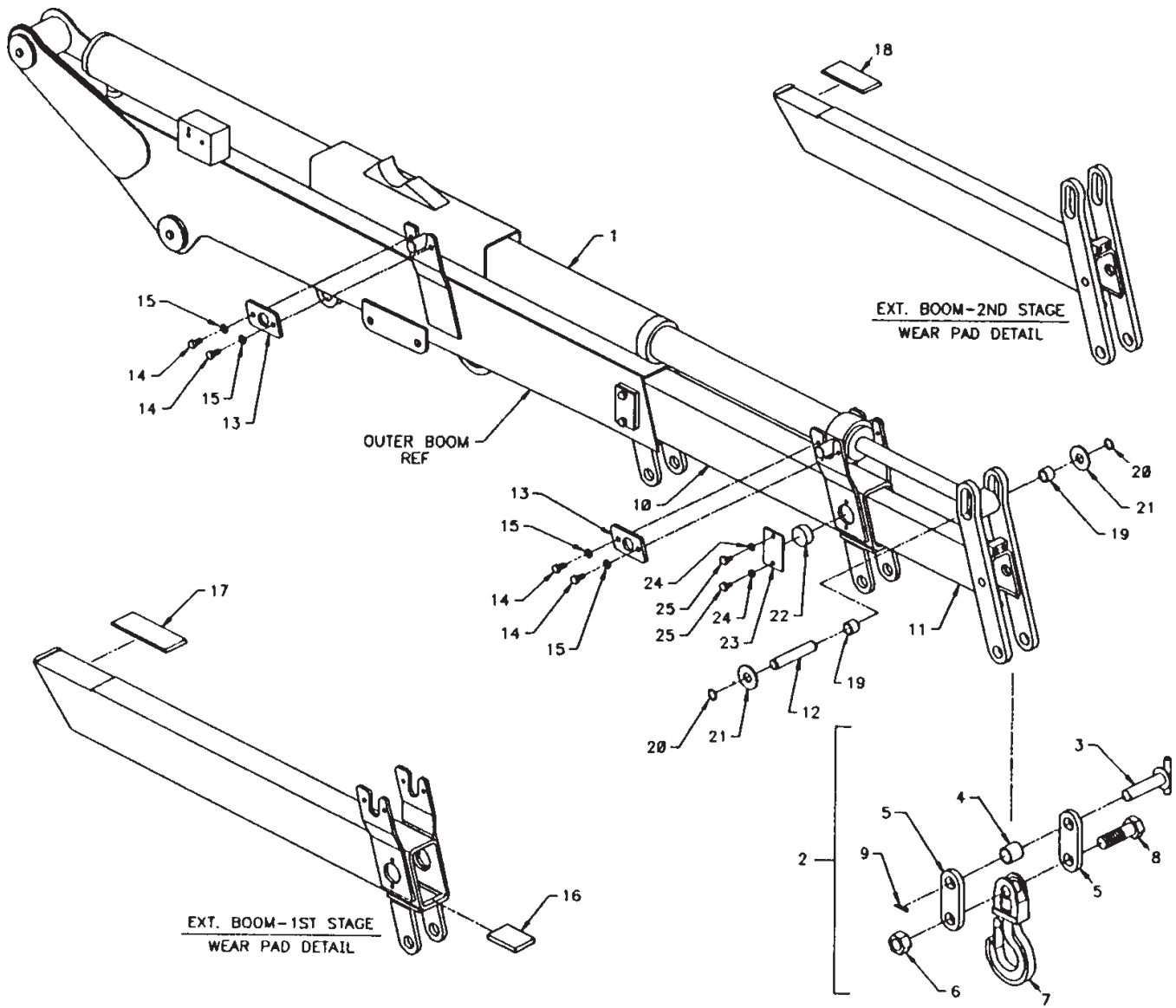

EXT BOOM ASM-2H1M (41710940)

ITEM	PART NO.	DESCRIPTION	QTY
1.	3K185920	TELESCOPIC CYLINDER	1
2.	51706200	HOOK ASM (INCL:3-9)	1
3.	52705801	PIN (PART OF 2)	1REF
4.	60108902	SPACER (PART OF 2)	1REF
5.	60107324	HOOK LINK (PART OF 2)	2REF
6.	72062073	NUT 1 1/4-7 LOCK (PART OF 2)	1REF
7.	70734177	SWVL HOOK 7TON (PART OF 2) (WAS 60103575)	1REF
8.	72601666	CAP SCR 1 1/4-7X4 HHGR5 (PART OF 2)	1REF
9.	72066145	HAIR PIN 3/16 (PART OF 2)	1REF
10.	52710941	1ST STG EXT BOOM	1
11.	52706708	2ND STG EXT BOOM	1
12.	60101906	PIN	1
13.	60107292	LOCK PLATE	4

14.	72060091	CAP SCR 1/2-13X1 HHGR5	8
15.	72063053	WASHER 1/2 LOCK	10
16.	60030173	WEAR PAD	1
17.	60030172	WEAR PAD	1
18.	60030174	WEAR PAD	1
19.	60020197	ROLLER	2
20.	72066125	RETAINING RING 1"	2
21.	72063010	WASHER 1 WRT	2
22.	60030060	WEAR PAD	2
23.	60107550	LOCK PLATE	2
24.	72063051	WASHER 3/8 LOCK	4
25.	72060044	CAP SCR 3/8-16X3/4 HHGR5	4
26.	52710938	3RD STG EXT BOOM	1
27.	52704383	PIN	1
28.	72066145	HAIR PIN 3/16	1
29.	60107294	STOP	1
30.	72060094	CAP SCR 1/2-13X1-3/4 HHGR5	2

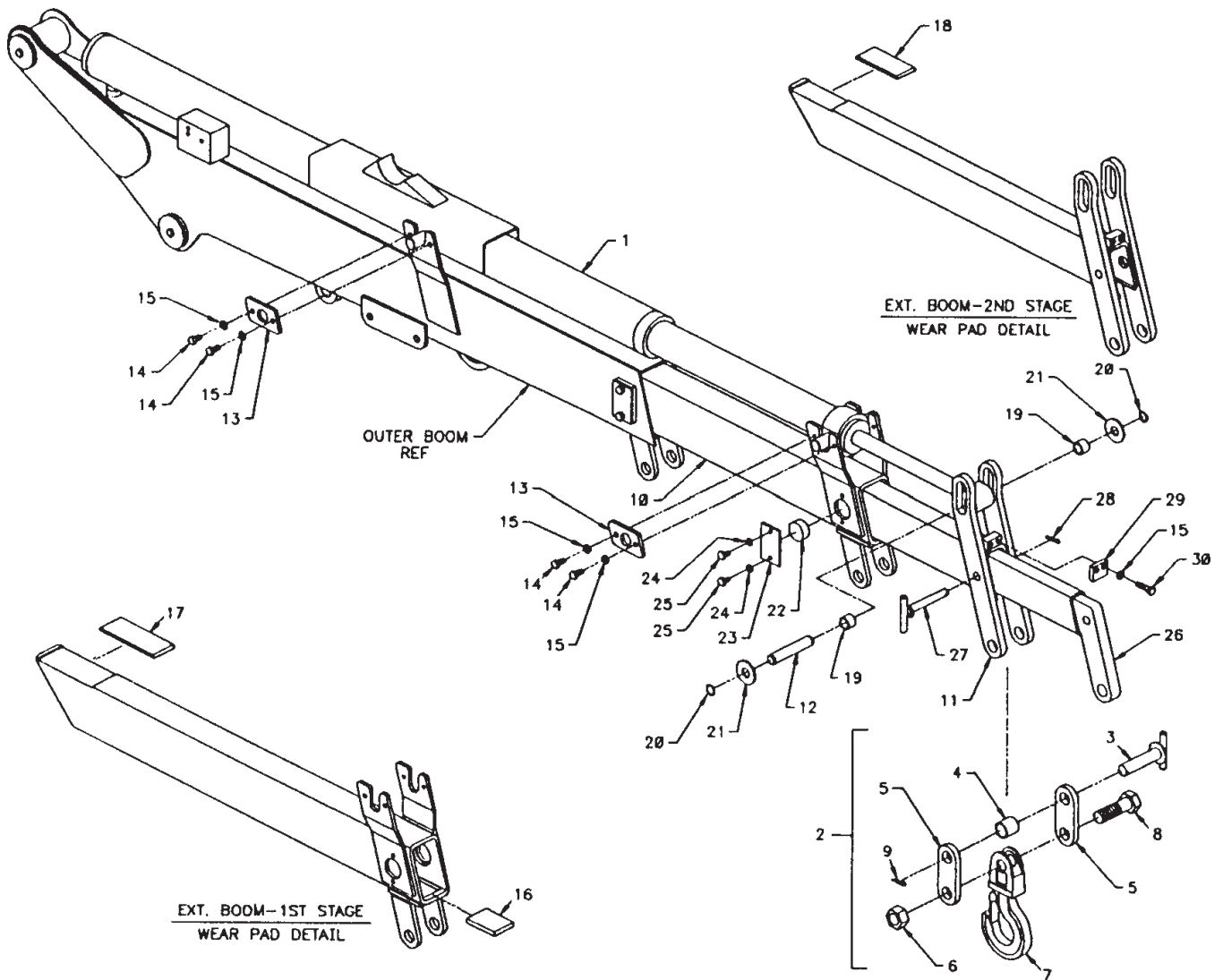

BASE & PWR OUT STABILIZER ASM (41712220-1)

DRAWING VIEW ON NEXTPAGE

1.	3B221850	CYLINDER	2
3.	70732573	RESERVOIR ASM 3625/4825	1
5.	71145016	SLIDING STOP BLOCK	1
8.	52712214	BASE (INCL 9-13)	1
9.	60020115	BUSHING	1REF
10.	60020116	BUSHING	1REF
11.	60020187	BUSHING	1REF
12.	60020188	BUSHING	1REF
13.	71056011	DRIVE GEAR	1REF
14.	52712252	ARM, OR	2
15.	52705871	LEG, OR	2
16.	53000714	EXT, GREASE	1
17.	53000717	EXT, GREASE	1
18.	60107648	CLAMP, HOSE	2
19.	60010235	CLOVER, PINION GEAR	2
21.	60010844	PLATE, GREASE	1
22.	60030053	ROLLER	4
23.	60102767	ACCESS HOLE COVER	1
24.	60106032	STUD, MOTOR BRK	2
25.	60106314	PIN, TYPE O	4
26.	60106886	SPACER, PINION GEAR	1
27.	60106968	PIN-TYPE A	2
28.	60102769	GUARD, INT. GEAR	1
29.	71056264	GEAR, INTERMEDIATE	1
30.	71056265	GEAR, PINION	1
31.	71056627	GEAR, TURNTABLE BEARING	1
33.	72053301	COUPLING, BLK 1/8	2
34.	72053508	ZERK, GREASE 1/8	3
35.	72060002	CAP SCR 1/4-20 X 3/4 HH GR5Z	2
36.	72060053	CAP SCR 3/8-16 X 2.75 HH GR5Z	2
37.	72060092	CAP SCR 1/2-13 X 1.25 HH GR5Z	2
38.	72060102	CAP SCR 1/2-13 X 5.5 HH GR5Z	4
39.	72060833	SCR, SELF-TAP 5/16-18 X 3/4 HH	2
40.	72062080	NUT, LOCK 1/2-13 HEX	2
41.	72062103	NUT, LOCK 3/8-16 HEX	8
42.	72062107	NUT, CTR LOCK 1/2-13 HEX	4
43.	72063002	WASHER, WRT 5/16	2
44.	72063003	WASHER, WRT 3/8	2
46.	72063039	MACH BUSHING 2.00 X 10 GA NR	1
47.	72063049	LOCKWASHER 1/4	2
48.	72063053	LOCKWASHER 1/2	2
49.	72063116	WASHER, FLAT 3/4	20
50.	72066095	RING, RETAINER, EXT 2" STD	1
51.	72066178	COTTER PIN, 1/8	8
52.	72060207	CAP SWCR 3/4-10 X 3.0 HH GR8	20
53.	73540004	MOTORASM	1
55.	72066125	RING, RETAINING EXT 1" HD	4
56.	72053281	ELBOW, STR 1/8	1
58.	72060046	CAP SCR 3/8-16 X 1 HH GR5Z	4
59.	72063003	WASHER, WRT 3/8	8
60.	72531826	RED BUSHING, STL 1/4-1/8	1
61.	72060023	CAP SCR 5/16-18 X 3/4 HH GR5Z	2
62.	72063050	LOCKWASHER 5/16	2
63.	60119748	CONTROL HANDLE GUARD	2
64.	72060005	CAP SCR 1/4-20 HH GR5	8
65.	72063001	WASHER 1/4 FLAT	16
66.	72062104	NUT 1/4-20 HEX SELF-LOCK	8

**BASE & PWR OUT STABILIZER ASM
(41712220-2)**

PARTS LIST ON PREVIOUS PAGE

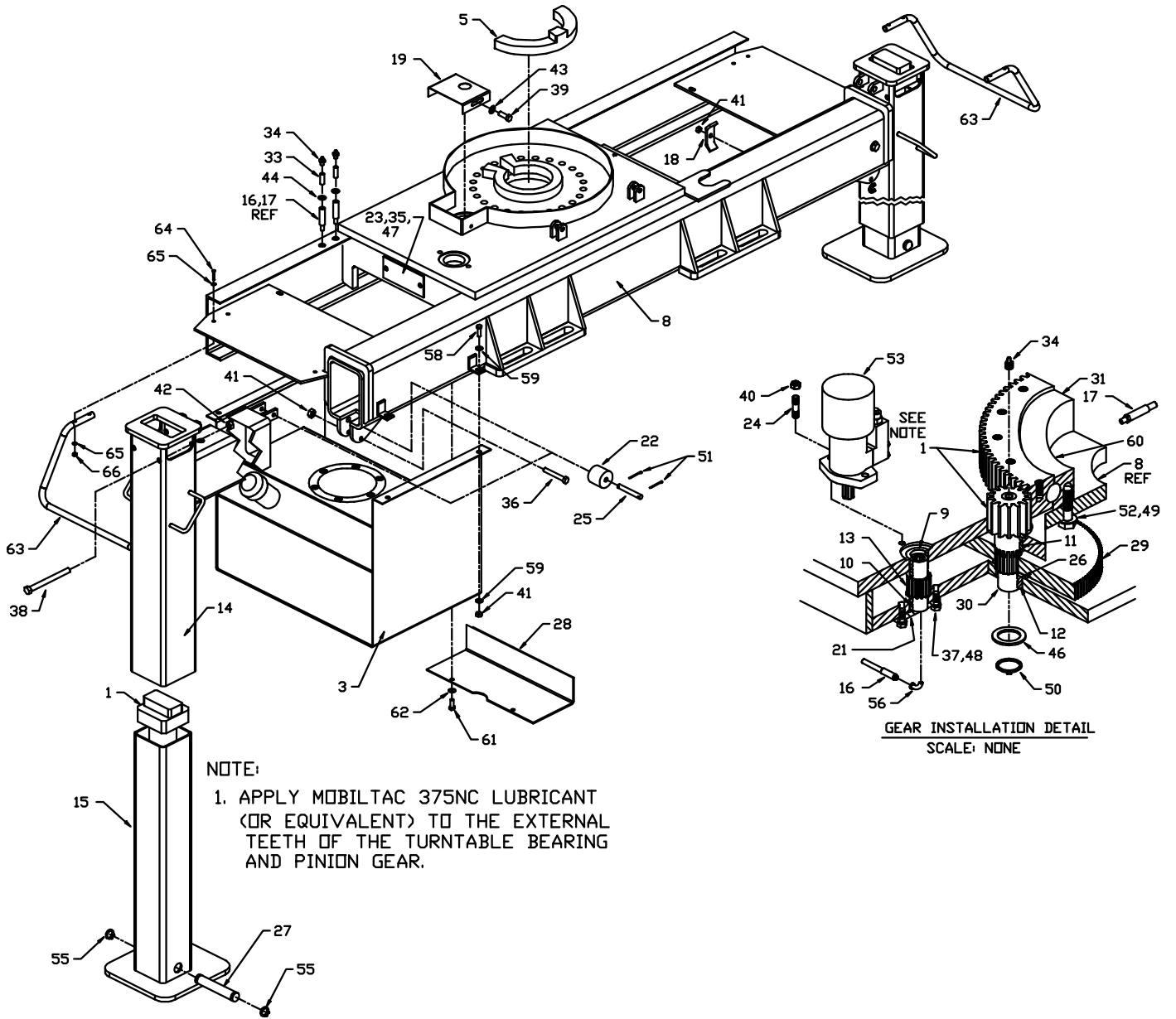

RESERVOIR ASM (70732573)

ITEM	PART NO.	DESCRIPTION	QTY
4.	(530047)	COVER	1
9.	(820117)	DIPSTICK ASM	1
10.	70144326	STRAINER 100MESH	1
11.	73052001	PLUG 3/4FPT SQHD MAGNETIC	1
13.	72062000	NUT 1/4-20 HEX	6
14.	72063001	WASHER 1/4 FLAT	6
15.	76393565	O-RING	1
18.	70034410	DIFFUSER 3/4NPT	1
19.	70732791	SCREEN 100MESH	1
20.	72053415	PLUG 3/4 SQHD STEEL	2

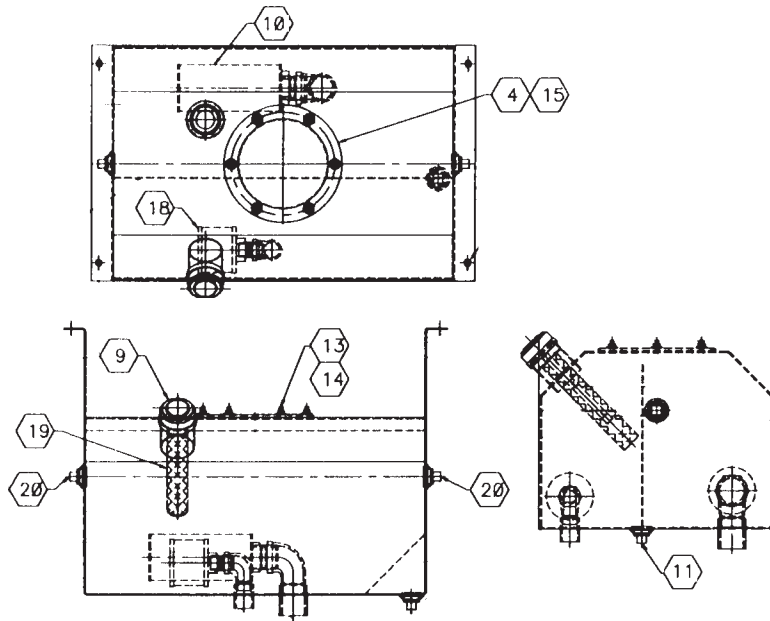

INSTALLATION KIT (93704355)

ITEM	PART NO.	DESCRIPTION	QTY
1.	70732573	RESERVOIR ASM 17.3GAL	1REF
2.	72060004	CAP SCR 1/4-20X1 HHGR5Z	2
3.	72060046	CAP SCR 3/8-16X1 HHGR5Z	4
4.	72062103	NUT 3/8-16 HEX NYLOC	4
5.	72062104	NUT 1/4-20 HEX NYLOC	2
6.	72063001	WASHER 1/4W	4
7.	72063003	WASHER 3/8W	8
8.	72066516	HOSE CLAMP 1-1/4 2BOLT	2
9.	72531427	ELBOW 3/4MPT #12MJIC 90°	4
10.	72532346	BARB NIPPLE 1-1/4 1-1/4 90°	1
11.	72532670	ELBOW #8MJIC #8FJIC 45°	1
12.	72532834	BEAD NIPPLE 1.00NPT 1-1/4 90°	1
13.	72532972	ADPTR #8MJIC #12FJIC	1
14.	73054129	GATE VALVE 3/4 BRASS	1

15.	72053141	PIPE NIPPLE BLK 3/4XCLOSE	1
16.	73052000	HYD FILTER 10MIC 3/4NPTF	1
17.	60121443	OIL FILTER BRACKET	1
18.	51393468	HOSE 3/4X60 #12F#12F	1
19.	51394360	HOSE 3/4X24 #12F#12F	1
20.	51394916	HOSE 1/2X99 #8F#8F	1
21.	60350060	HOSE 1-1/4 100R4 X 63	1
23.	60010354	CLAMP PLATE	4
24.	60107478	WASHER-SQUARE TIE DOWN	8
25.	60107829	STUD-TIE DOWN 1X18	8
26.	52706660	SUPPORT-TRUCK FRAME 9-1/2	4
27.	72062141	NUT 1-8 HEX LOCK	16
28.	72063066	WASHER 1.00 HI STR	8
30.	72060002	CAP SCR 1/4-20X3/4 HHGR5Z	2
31.	72063049	WASHER 1/4 LOCK	2

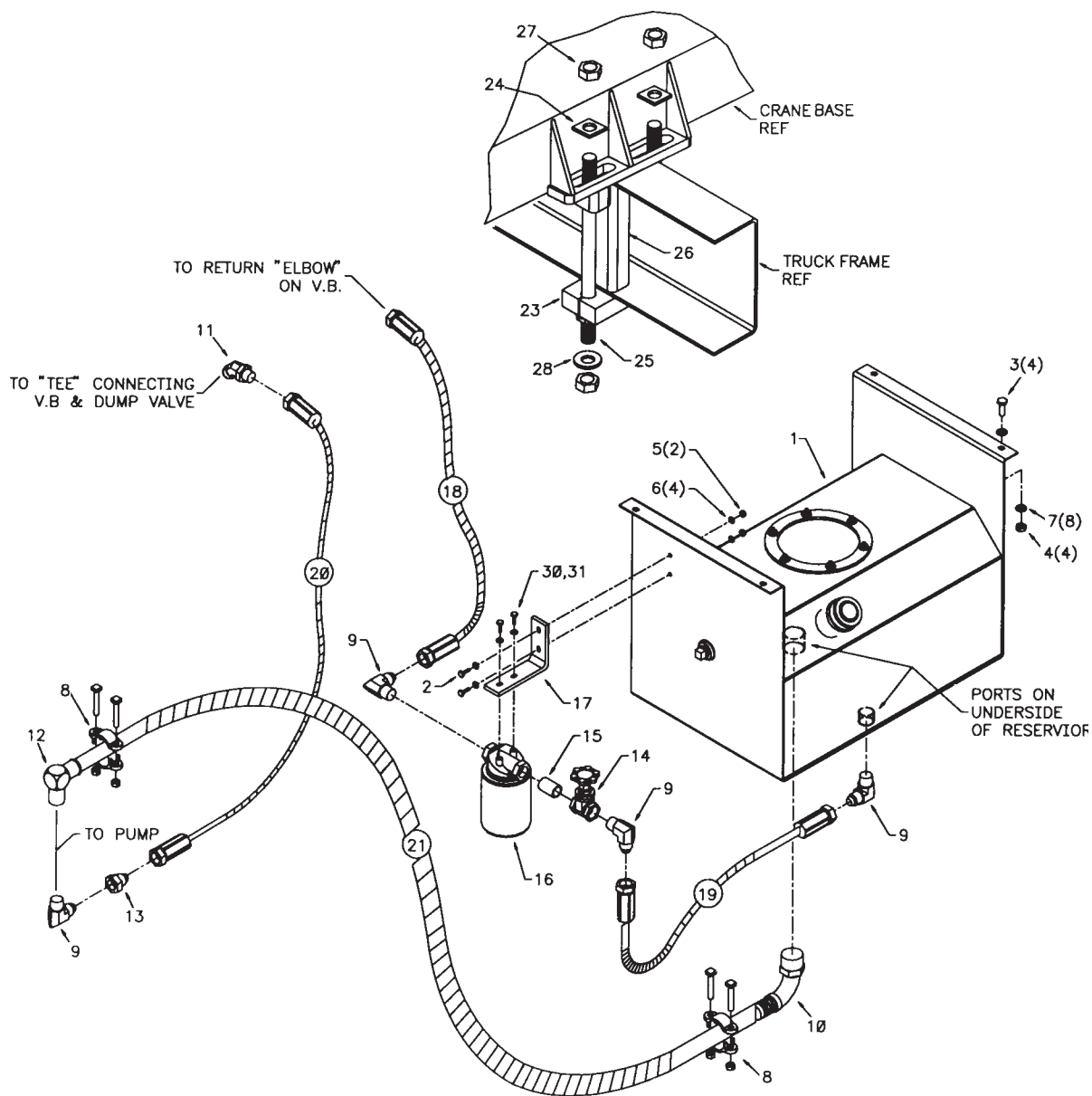

DECAL KIT-5200 SERIES CRANE (95712260-1)

- 1. 70029251 IMT DIAMOND 2
- 2. 70391583 DECAL-SETUP/STOW 2
- 3. 70391612 DECAL-GREASE WEEKLY LH 4
- 4. 70391613 DECAL-GREASE WEEKLY RH 5
- 5. 70392108 DECAL-SUCTION LINE 1
- 6. 70392109 DECAL-RETURN LINE 1
- 7. 71393822 DECAL-5200 SERIES IDENT 2
- 8. 70392213 DECAL-CAUTION WASH/WAX 1
- 9. 70392524 DECAL-ROTATE/GREASE 1
- 10. 70392813 DECAL-DANGER ELECTRO 2
- 11. 70392814 DECAL-WARNING OPERATOR 2
- 12. 70392815 DECAL-WARNING OPERATION 2
- 13. 70392864 DECAL-WARN STAB STD CLR 2
- 14. 70392865 DECAL-DANGER ELECTRO 4
- 15. 70392866 DECAL-WARNING OPER COND 2

- 17. 70392888 DECAL-WARN OPER RESTRICT 2

- 18. 70392890 DECAL-DGR STOW/UNFOLD 2
- 19. 70392891 DECAL-DANGER DRIVELINE 2
- 20. 70392982 DECAL-CONTACT IMT 1
- 21. 71039134 DECAL-CAUTION OIL LEVEL 1
- 22. 71393864 CAPACITY PLACARD 2
- 23. 71392255 DECAL-CTRLS STREETSIDE 1
- 24. 71392256 DECAL-CTRLS CURBSIDE 1
- 25. 71392257 DECAL-STAB PWR DN SS 1
- 26. 71392258 DECAL-STAB PWR DN CS 1
- 27. 71392365 DECAL-ROTATIONALIGNMENT 1
- 28. 70392889 DECAL-DGR RC ELECTRO LG 2
- 29. 70394190 DECAL-CAUTION NOT A STEP 2
- 30. 70394189 PLACARD-OIL REC 1
- 31. 70394443 DECAL-DGR FREEFALLING BM 1REF
- 32. 70392868 DECAL-DANGER CR LOADLINE 4
- 33. 70392863 DECAL-DANGER HOIST PERS 2
- 34. 70395323 DECAL-ASME/ANSI B30.22 1
- 35. 72042097 LEVEL 2

CONTINUED ON FOLLOWING PAGE

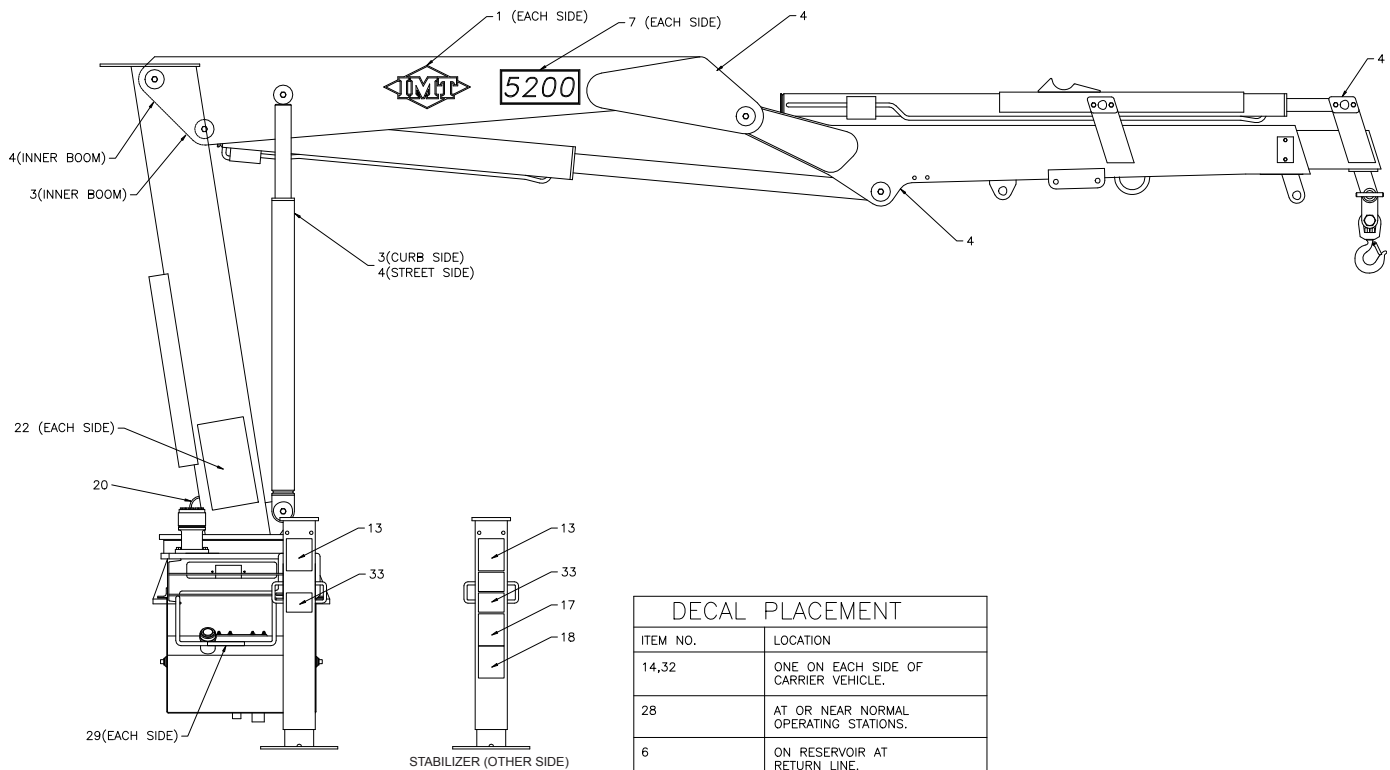

DECAL PLACEMENT	
ITEM NO.	LOCATION
14,32	ONE ON EACH SIDE OF CARRIER VEHICLE.
28	AT OR NEAR NORMAL OPERATING STATIONS.
6	ON RESERVOIR AT RETURN LINE.
5	ON RESERVOIR SUCTION LINE.
19	AT OR NEAR THE DRIVELINE.
31	AT OR NEAR THE MANUAL BOOM EXT. RETENTION MECHANISM.
34	PLACE UNDER SERIAL TAG

NOTE: INSTALL #35, LEVEL, ON FRONT AND SIDE OF CRANE BASE.

**DECAL KIT-5200 SERIES CRANE
(95712260-2)**

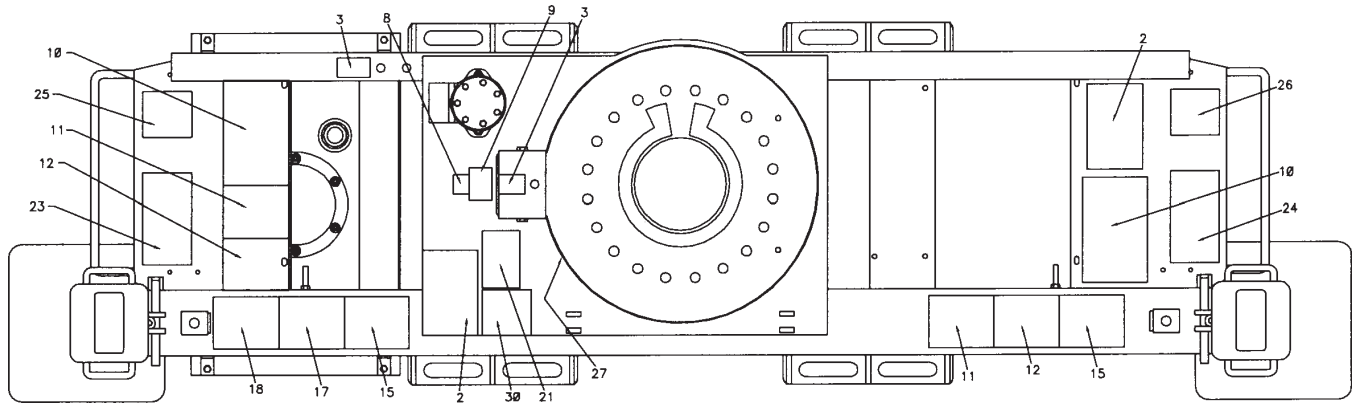

HYDRAULIC KIT (91710962)

1.	51710944	VALVEBANK ASM	1REF
2.	51393928	HOSE ASM 1/4X51 #4F#4F	2REF
3.	51393957	HOSE ASM 3/8X33 #6F#8F	2REF
4.	51393922	HOSE ASM 3/8X26 #8F#8F	1REF
5.	51393923	HOSE ASM 3/8X111 #6F#8F	2REF
6.	51393955	HOSE ASM 3/8X113 #6F#6F	2REF
7.	51393956	HOSE ASM 3/8X231 #6F#8F	1REF
8.	51393954	HOSE ASM 3/8X93 #6F#6F	2REF
9.	72532700	ELBOW 9/16MSTR 9/16MJICXLG	4
10.	72532690	ELBOW 7/16MJIC 7/16FJIC	2
11.	51393958	HOSE ASM 1/2X231 #8F#8F	1REF
12.	72532351	ADAPTER 7/16MSTR 7/16MJIC	3
13.	72532358	ADAPTER 3/4MSTR 3/4MJIC (WAS 8)	9
14.	72531205	TEE 3/4MJIC 1/2TUBE	2

15.	72062103	NUT 3/8-16 LOCK	3
16.	72060048	CAP SCR 3/8-16X1-1/2 HH GR5	3
17.	51716367	HOSE KIT (INCL:2-8,10,26-29)	1
18.	72053763	ELBOW #8MSTR #8MJIC 90°	2
19.	73540061	C'BAL VALVE	1
20.	72060008	CAP SCR 1/4-20X2 HHGR5	2
21.	72063049	WASHER 1/4 LOCK	2
22.	72532657	TEE #8JIC SWVLNUTRUN	1
23.	72532665	ADAPTER #4MJIC #8FJIC	1
24.	72533663	ELBOW #8MJIC #8MJIC 90°	1
25.	51395859	HOSE-FJ .25X14.5 #4#4 (PO 17)	1REF
26.	51394424	HOSE-FF .38X12 #8#8 (PO 17)	2REF
27.	51395858	HOSE-FF .38X20 #8#8 (PO 17)	1REF
28.	51394588	HOSE-FF .38X41 #8#8 (PO 17)	1REF
29.	51395954	HOSE-FJ .38X22 #8#8 (PO 17)	1REF
30.	72532980	SWIVEL #8MJIC #8FJIC IN-LINE	1
31.	73054426	VALVE-ADJ RELIEF	1

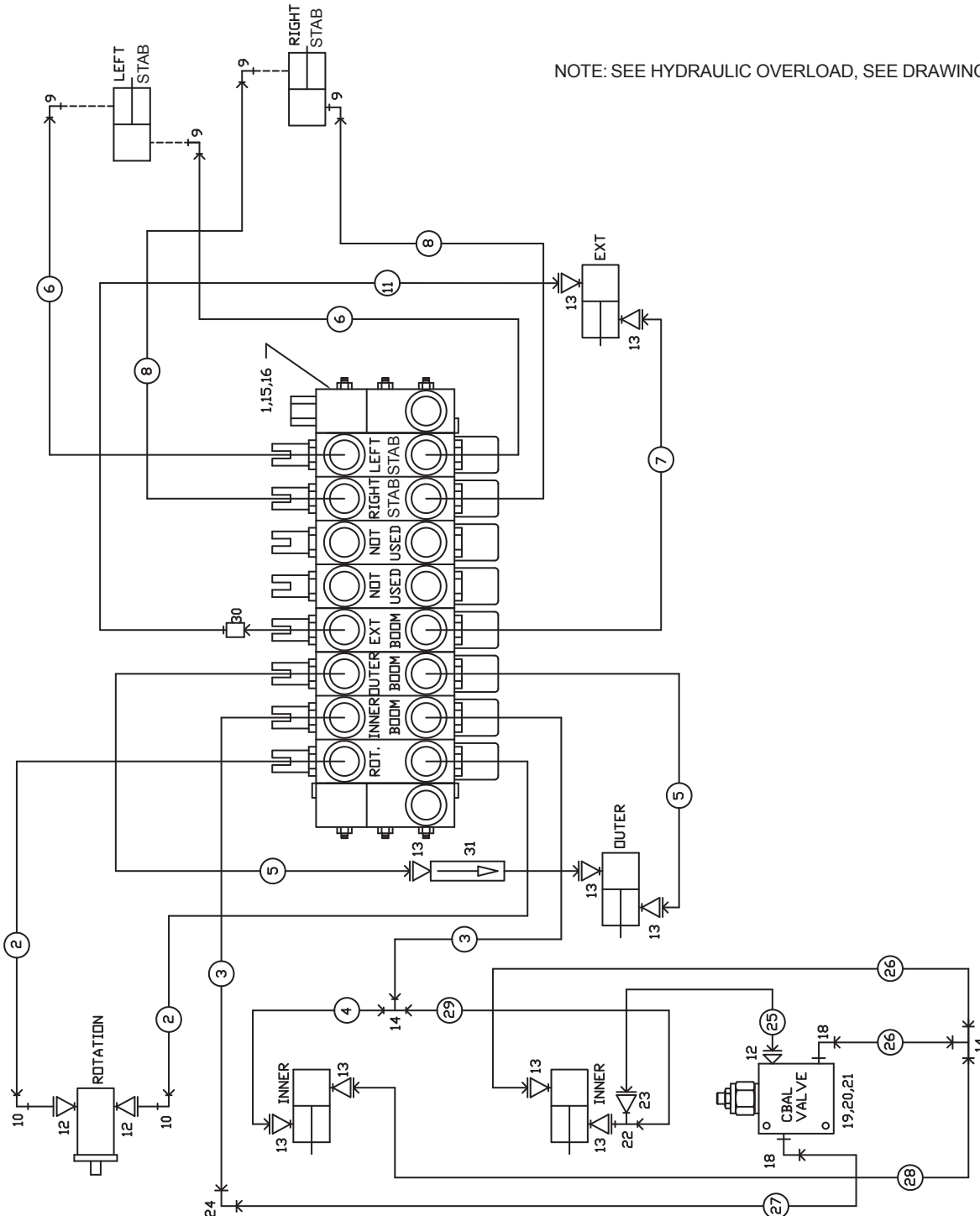

NOTE: SEE HYDRAULIC OVERLOAD, SEE DRAWING 51717127.

SELECTOR VALVE-HYDRAULIC SCHEMATIC (31717782)

- | | | | |
|-----|----------|-------------------------------|------|
| 1. | 73054420 | SELECTOR VALVE | 1 |
| 2. | 72532951 | ADPTR #12 MSTR #8 FSTR | 3 |
| 3. | 72053763 | ELBOW #8MSTR #8MJIC 90° | 3 |
| 4. | 72532665 | ADPTR #4MJIC #8FJIC | 3 |
| 5. | 51703659 | HOSE ASM FF 1/4 X 22.00 | 2 |
| 6. | 72533239 | ADPTR #4MJIC #4MJIC | 2 |
| 7. | 72532981 | TEE-SWIVEL NUT RUN JIC#4 | 1 |
| 8. | 72532690 | ELBOW #4MJIC #4FJIC SWIVEL | 1 |
| 9. | 51396095 | HOSE FF 1/4 X 65.00 OAL (4-4) | 1 |
| 10. | | EXISTING HOSE TO BOOM TIP | 2REF |
| 11. | | EXISTING HOSE TO BOOM TIP | 2REF |

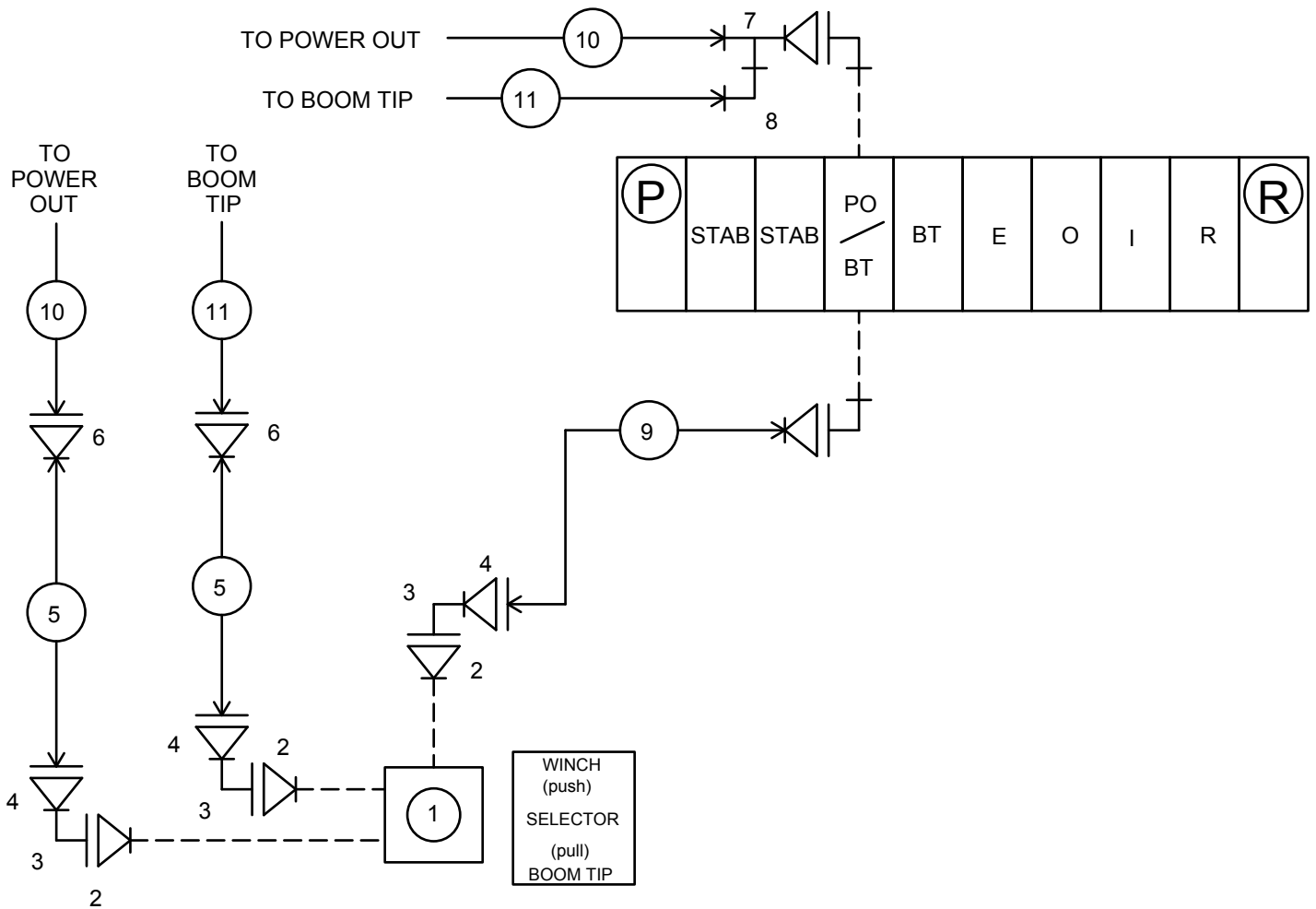

HYDRAULIC OVERLOAD KIT (51717127)

1.	72532657	TEE-SWIVEL NUT RUN JIC#8	1
2.	72532658	ELBOW #8MJIC #8FJIC SWIVEL	1
3.	73540463	VALVE BLOCK ASSEMBLY	1
4.	72532358	ADPTR-M STR/M JIC 8 8	6
5.	73054426	VALVE-ADJ RELIEF	1
6.	72533374	TEE-SWIVEL NUT RUN JIC 6	3
7.	72532950	TEE-SWIVEL NUT RUN JIC 12	1
8.	72532696	ELBOW-MJIC/FJIC SW 12 12	1
9.	72532972	ADAPTER MJIC/FJIC 8 12	1
10.	72532772	ELBOW MJIC/FJIC SW 6 6	3
11.	72532141	PLUG-STR HEX HD STL .75 THD	3
12.	51395154	HOSE-FF .38 X .51 OAL (6-8)	3
13.	51394546	HOSE-FF .38 X 51 OAL (8-8)	2
14.	51395153	HOSE-FF .50 X 8.0 OAL (8-8)	1
15.	72060034	CAP SCR .31-18 X 3.25 HHGR5Z	3
16.	72062109	NUT .31-18 HEX NYLOC ZINC	3
17.	72532360	ADAPTER-MSTR/MJIC 12 8	1
18.	77441025	HARNES-OVERLOAD	1

NOTES:

- 1) The overload system functions such that when the inner cylinders are overloaded, the pressure switch mounted on the inner cylinder will activate the solenoid dump valve(s), thus dumping oil to "tank" instead of the outer cylinder "extend", extension cylinder "extend", or winch "up" functions. This will prevent pressure build-up for these functions, as the system is based on the oil taking the path of least resistance.
- 2) The functions that will shut down, if overloaded, are:
 - a) Inner Boom "Retract"
 - b) Outer Boom "Extend"
 - c) Extension Cylinder "Extend"
 - d) Winch "Up"
- 3) Install a relief (#73054426 - 700 psi) in the extend line of the extension cylinder so the cylinder will not extend when the dump system is activated.
- 4) This system is used in conjunction with the electric capacity alert kit.

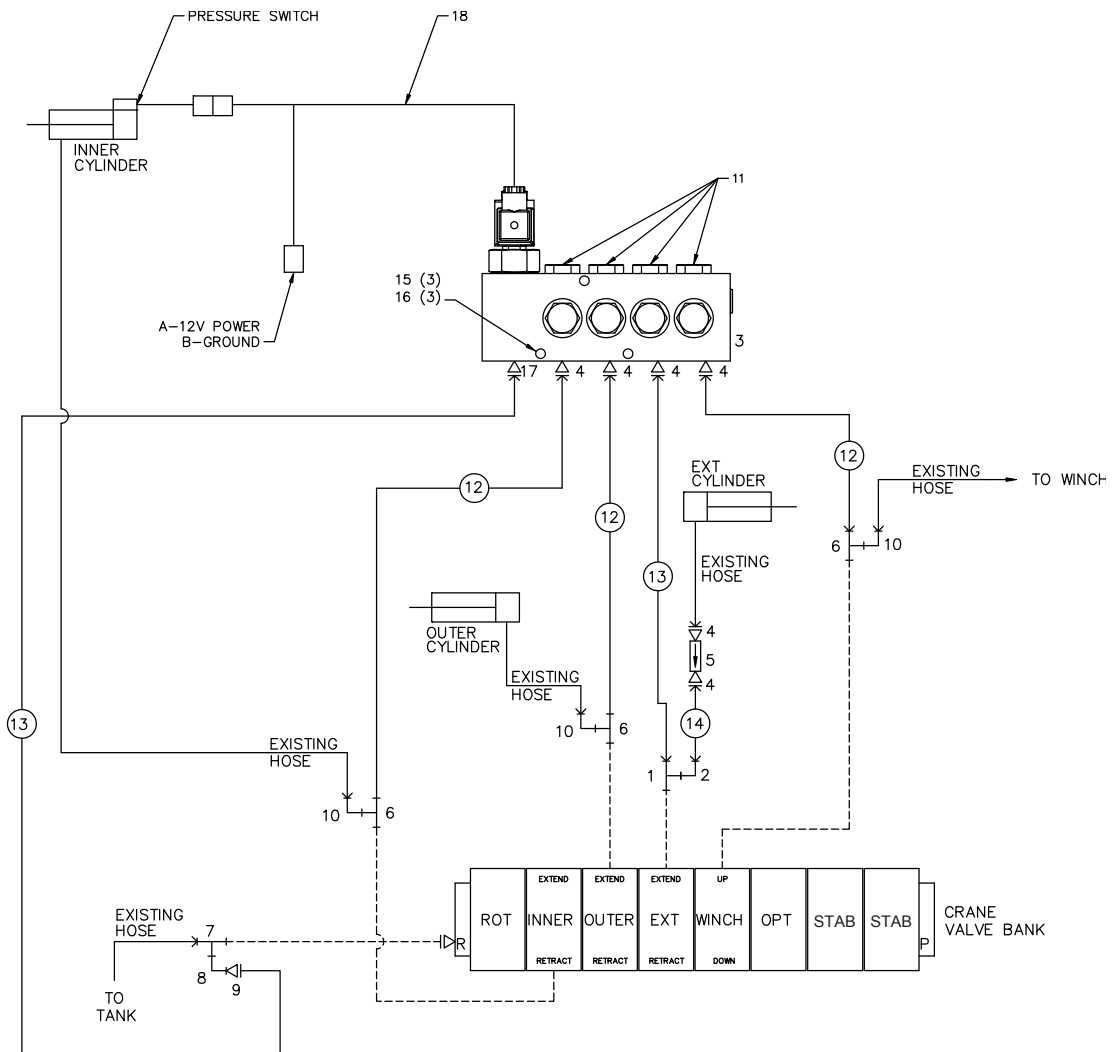

VB ASM-8 SECT/MNL (51710944)

ITEM	PART NO.	DESCRIPTION	QTY
1.	72532722	ADAPTER #10MSTR #6FSTR	16
2.	72532738	CAP 9/16JIC STL	4
3.	72053760	ELBOW #6MSTR #6MJIC 90°	7
4.	72053763	ELBOW #8MSTR #8MJIC 90°	1
5.	72053766	ELBOW #10MSTR #12MJIC 90°	1
6.	72532707	ADAPTER #4MJIC #6FJIC	2
7.	72532700	ELBOW #6MSTR #6MJIC XLG	8
8.	72532657	TEE 3/4JIC SWVL NUT	1
9.	72532675	CAP 3/4JIC STL	1
10.	70731499	VALVEBANK 8-SECTION	1
11.	72053763	ELBOW #6MSTR #8MJIC 90°	1

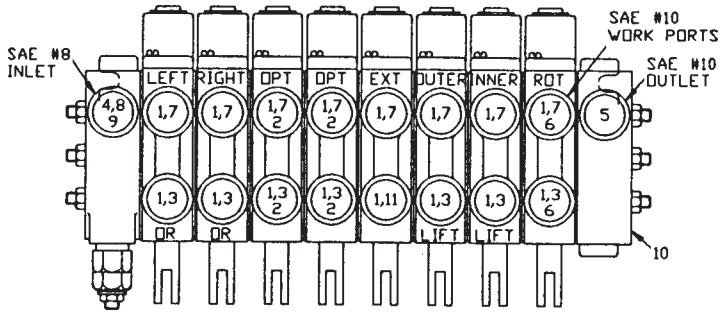

VALVEBANK (70731499)

ITEM	PART NO.	DESCRIPTION	QTY
1.	73054490	TANDEM VALVE SECTION	8
2.	73054488	END CAP LH	1
3.	94731681	TIE ROD KIT	1
4.	73731576	END CAP RH	1
5.	7Q072018	O-RING	18
6.	7Q072021	O-RING	9
7.	7Q072017	O-RING	9

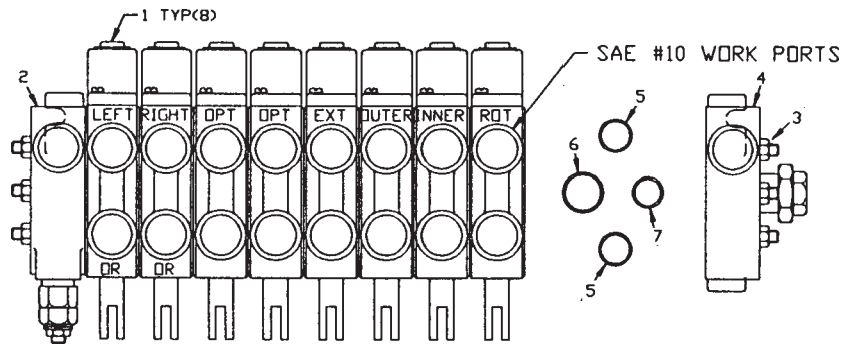

VB ASM 4R/4M (51711707)

ITEM	PART NO.	DESCRIPTION	QTY
1.	70732848	VALVEBANK 8-SECT	1
2.	72533052	ADAPTER #8MSTR #6FSTR	15
3.	72532738	CAP 9/16JIC	4
4.	72053760	ELBOW #6MSTR #6MJIC 90°	7
5.	72053763	ELBOW #8MSTR #8MJIC 90°	2
6.	72053766	ELBOW #10MSTR #12MJIC 90°	1
7.	72532707	ADAPTER #4MJIC #6FJIC	2
8.	72532700	ELBOW #6MSTR #6MJIC XLG	8
11.	72053764	ELBOW #10MSTR #8MJIC 90°	1

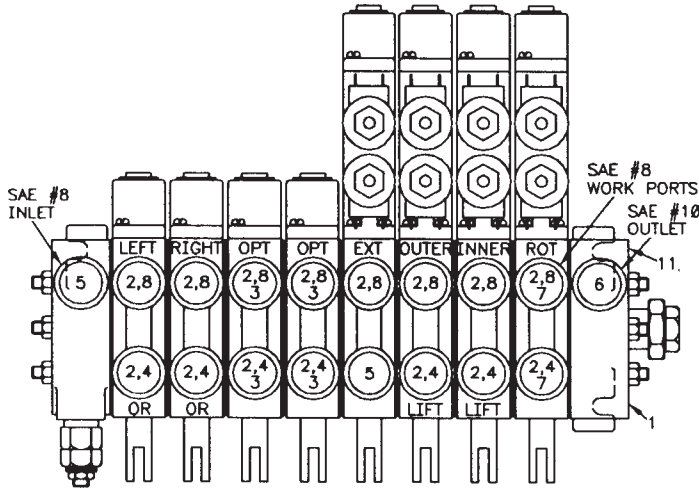

VALVEBANK (70732848)

ITEM	PART NO.	DESCRIPTION	QTY
1.	73540007	VALVE SECTION-MNL	4
2.	73054845	VALVE SECTION-RMT	4
3.	73054488	END COVER LH	1
4.	73540009	END COVER RH	1
5.	94731681	TIE ROD KIT	1
6.	7Q072018	O-RING	18
7.	7Q072021	O-RING	9
8.	7Q072017	O-RING	9

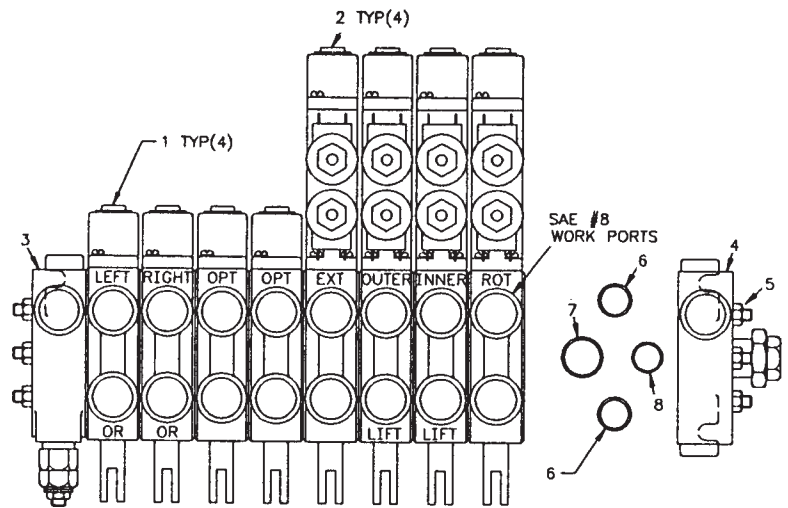

VB ASM 5R/3M (51711706)

ITEM	PART NO.	DESCRIPTION	QTY
1.	70732847	VALVEBANK 8-SECT	1
2.	72533052	ADAPTER #8MSTR #6FSTR	15
3.	72532738	CAP 9/16JIC	4
4.	72053760	ELBOW #6MSTR #6MJIC 90°	7
5.	72053763	ELBOW #8MSTR #8MJIC 90°	2
6.	72053766	ELBOW #10MSTR #12MJIC 90°	1
7.	72532707	ADAPTER #4MJIC #6FJIC	2
8.	72532700	ELBOW #6MSTR #6MJIC XLG	8
11.	72053764	ELBOW #10MSTR #8MJIC 90°	1

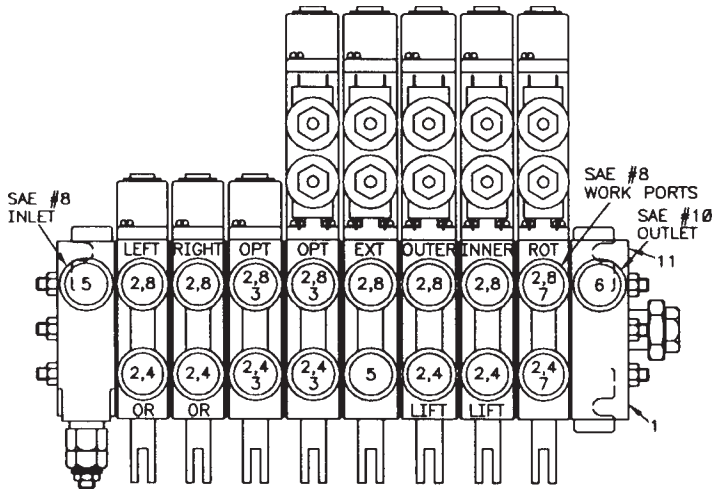

VALVEBANK (70732847)

ITEM	PART NO.	DESCRIPTION	QTY
1.	73540007	VALVE SECTION-MNL	3
2.	73054845	VALVE SECTION-RMT	5
3.	73054488	END COVER LH	1
4.	73540009	END COVER RH	1
5.	94731681	TIE ROD KIT	1
6.	7Q072018	O-RING	18
7.	7Q072021	O-RING	9
8.	7Q072017	O-RING	9

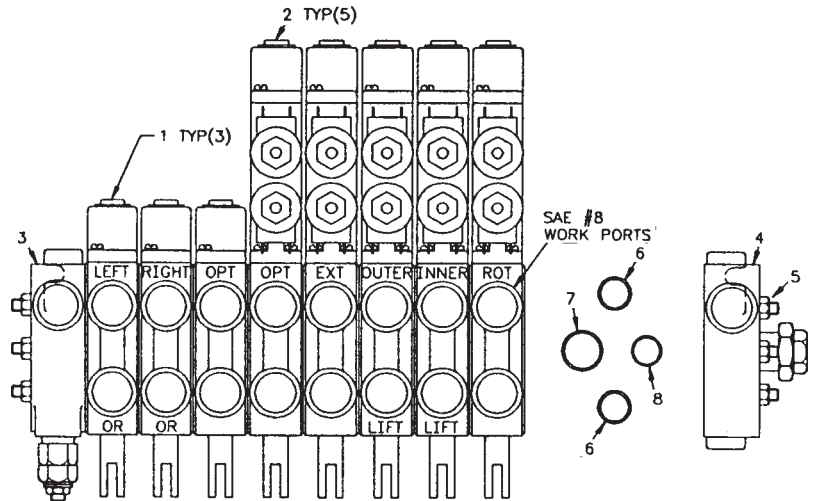

VB ASM 6R/2M (51711708)

ITEM	PART NO.	DESCRIPTION	QTY
1.	70732849	VALVEBANK 8-SECT	1
2.	72533052	ADAPTER #8MSTR #6FSTR	15
3.	72532738	CAP 9/16JIC	4
4.	72053760	ELBOW #6MSTR #6MJIC 90°	7
5.	72053763	ELBOW #8MSTR #8MJIC 90°	2
6.	72053766	ELBOW #10MSTR #12MJIC 90°	1
7.	72532707	ADAPTER #4MJIC #6FJIC	2
8.	72532700	ELBOW #6MSTR #6MJIC XLG	8
11.	72053764	ELBOW #10MSTR #8MJIC 90°	1

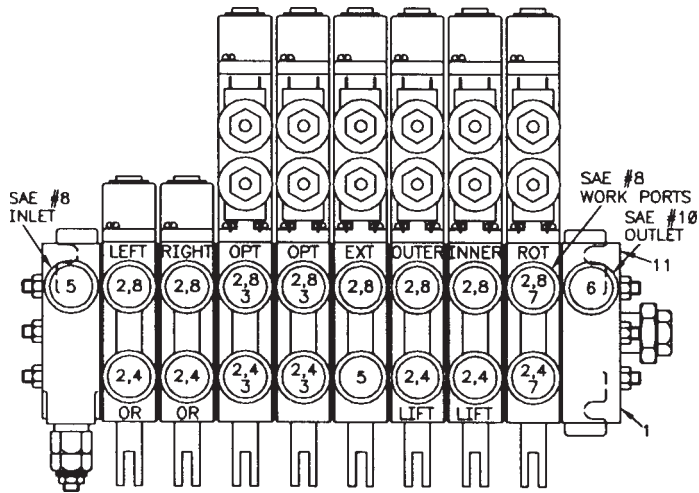

VALVEBANK (70732849)

ITEM	PART NO.	DESCRIPTION	QTY
1.	73540007	VALVE SECTION-MNL	2
2.	73054845	VALVE SECTION-RMT	6
3.	73054488	END COVER LH	1
4.	73540009	END COVER RH	1
5.	94731681	TIE ROD KIT	1
6.	7Q072018	O-RING	18
7.	7Q072021	O-RING	9
8.	7Q072017	O-RING	9

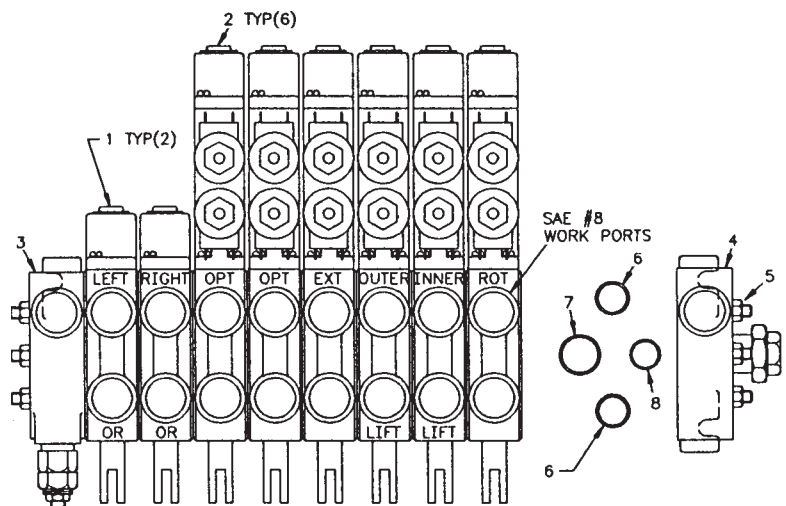

CONTROL KIT 6F MNL (90704417)

ITEM	PART NO.	DESCRIPTION	QTY
1.	52704397	CTRL HNDL MTG ROD	2
2.	52704744	CONTROL ROD F	6
3.	52704745	CONTROL ROD M	12
4.	70029451	CONTROL HANDLE	12
5.	71039096	KNOB	12
6.	60030068	SPACER 1-3/8	2
7.	60030069	SPACER 1-3/4	6
9.	72066338	CLEVIS PIN 5/16X1	12
10.	72661169	CLEVIS PIN 5/16X3/4	6
11.	72066168	COTTER PIN 3/32X3/4	18
12.	72063119	WASHER 5/8	8

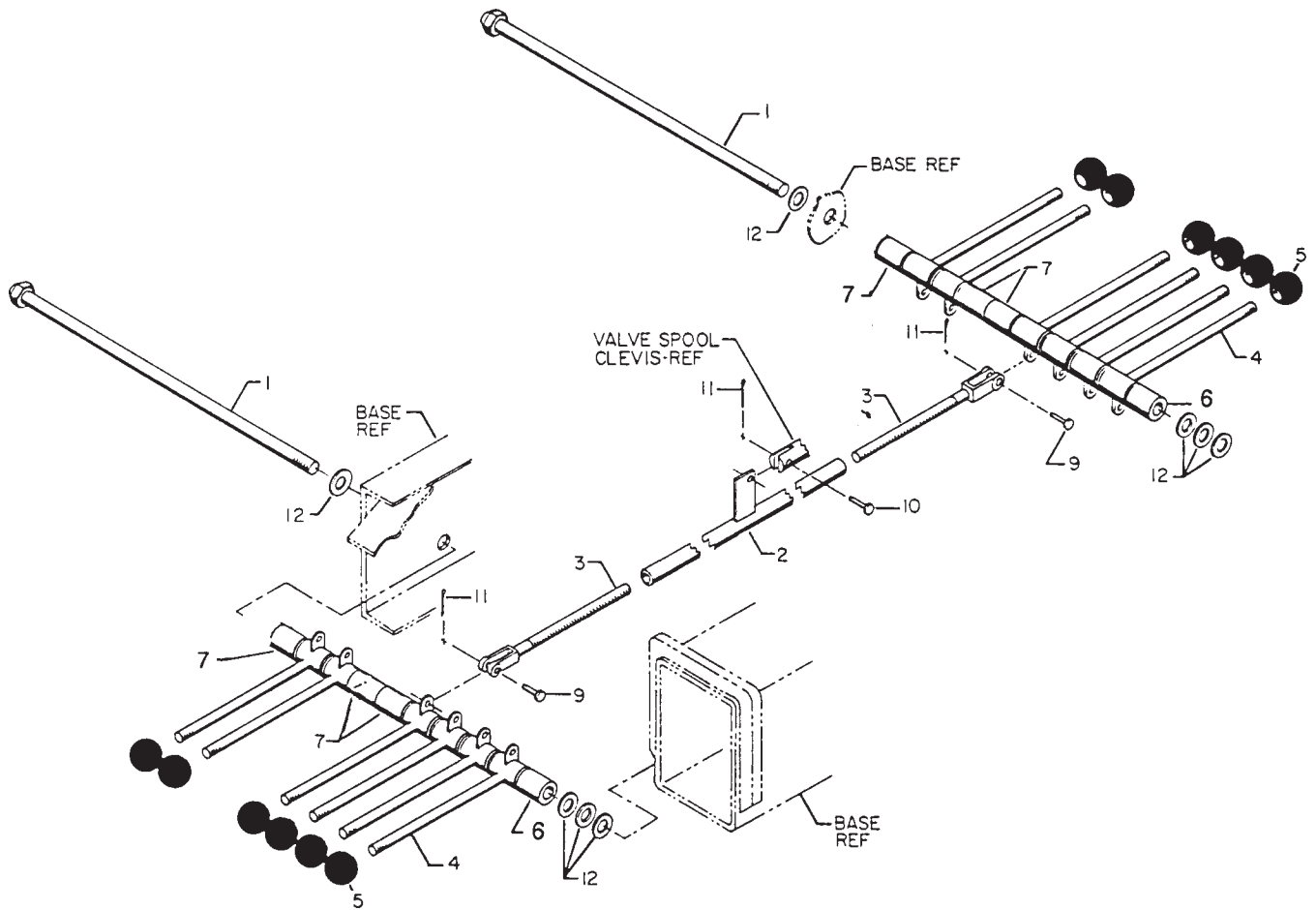

PROP'L RMT CONTROL KIT (90716707)

CONTINUED ON NEXT PAGE

- 1. 77044837 VALVE DRIVER-REPL W/COMMAND ARTCL 1
- 2. 72060703 CAP SCR .25-20 x .50 SH 2
- 3. 72063049 WASHER .25 LOCK 2
- 4. 77040186 TERM - F SLPON I .25 TAB 16-14GA 2
- 5. 73054876 PROPORTIONAL PRIORITY FLOW VALVE - 3000 1
- 6. 72060051 CAP SCR .38-16X2.5 HHGR5 2
- 7. 72062103 NUT .38-16 SLFLKG 2
- 8. 51713568 CABLE ASM-JIC BOX 6x6x4 1
- 9. 51713429 HANDLE ASM-REMOTE CONTROL 1
- 10. 77041251 BOSCH RELAY 2
- 11. 77041237 SOLENOID 12V 1
- 12. 51704784 CABLE ASM #1WIRE X 6.00" 1
- 13. 72060004 CAP SCR .25-20X1 HHGR5 Z 4
- 14. 72062104 NUT .25-20 HEX NYLOC Z 4

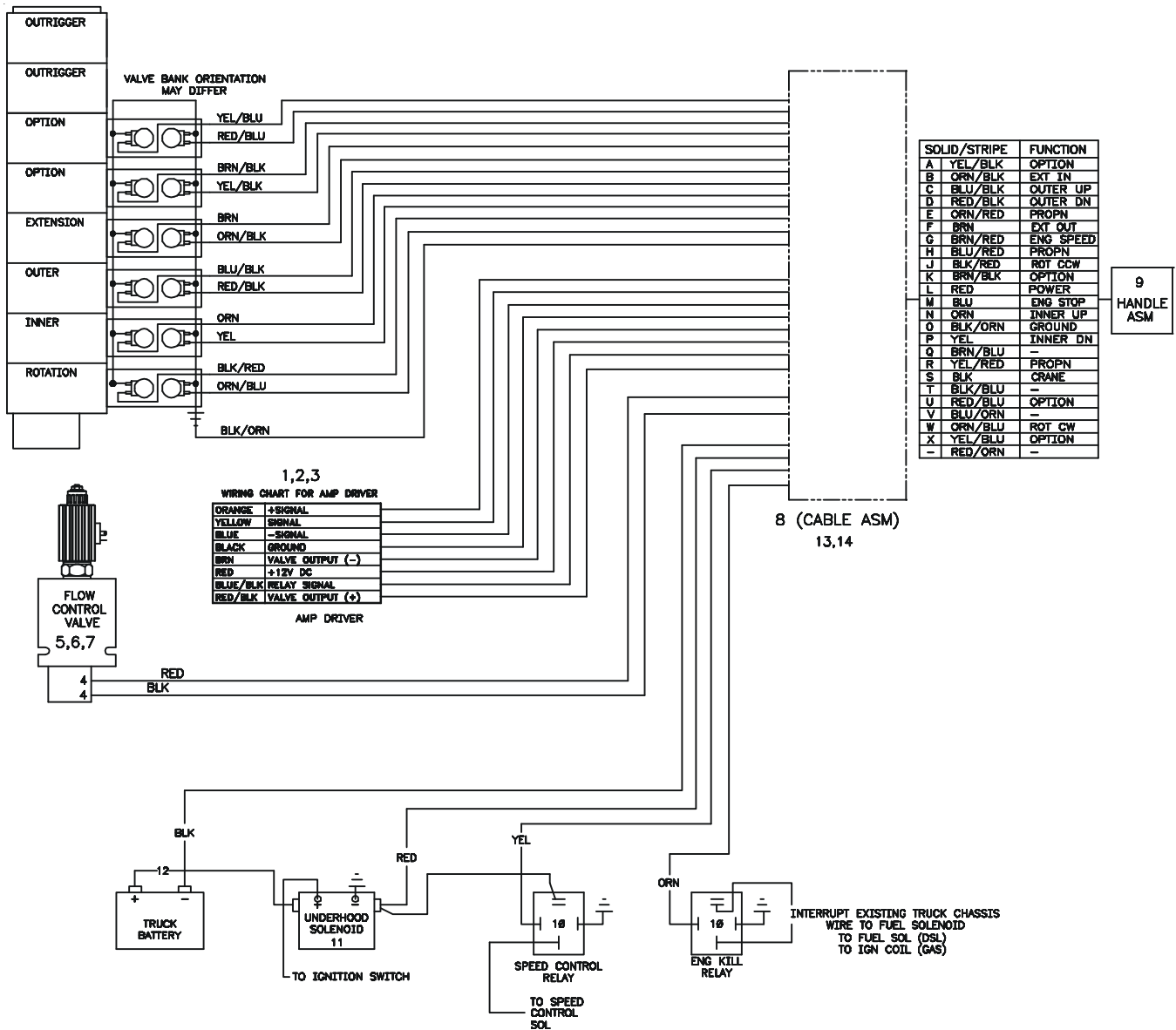

SCHEMATIC – REMOTE CONTROL KIT V12R (90716707)

ITEM	PART NO.	DESCRIPTION	QTY
1.	73054876	VALVE-PROP N PRIORITY FLOW REF	
2.	51709389	HOSE ASM 1/2X14 #8F#8F	1
3.	51716706	HOSE ASM 1/2X9 #8F#8F	1
4.	72532360	ADAPTER #12MSTR #8MJIC	1
5.	72532358	ADAPTER #8MSTR #8MJIC	2
6.	73054426	RELIEF VALVE 750 PSI	1
7.	51708692	HOSE ASM 3/8X4 #8F#8F	1
8.	72532951	ADAPTER #12MSTR #8FSTR	2
9.	72053763	ELBOW #8MSTR #8MJIC 90°	3

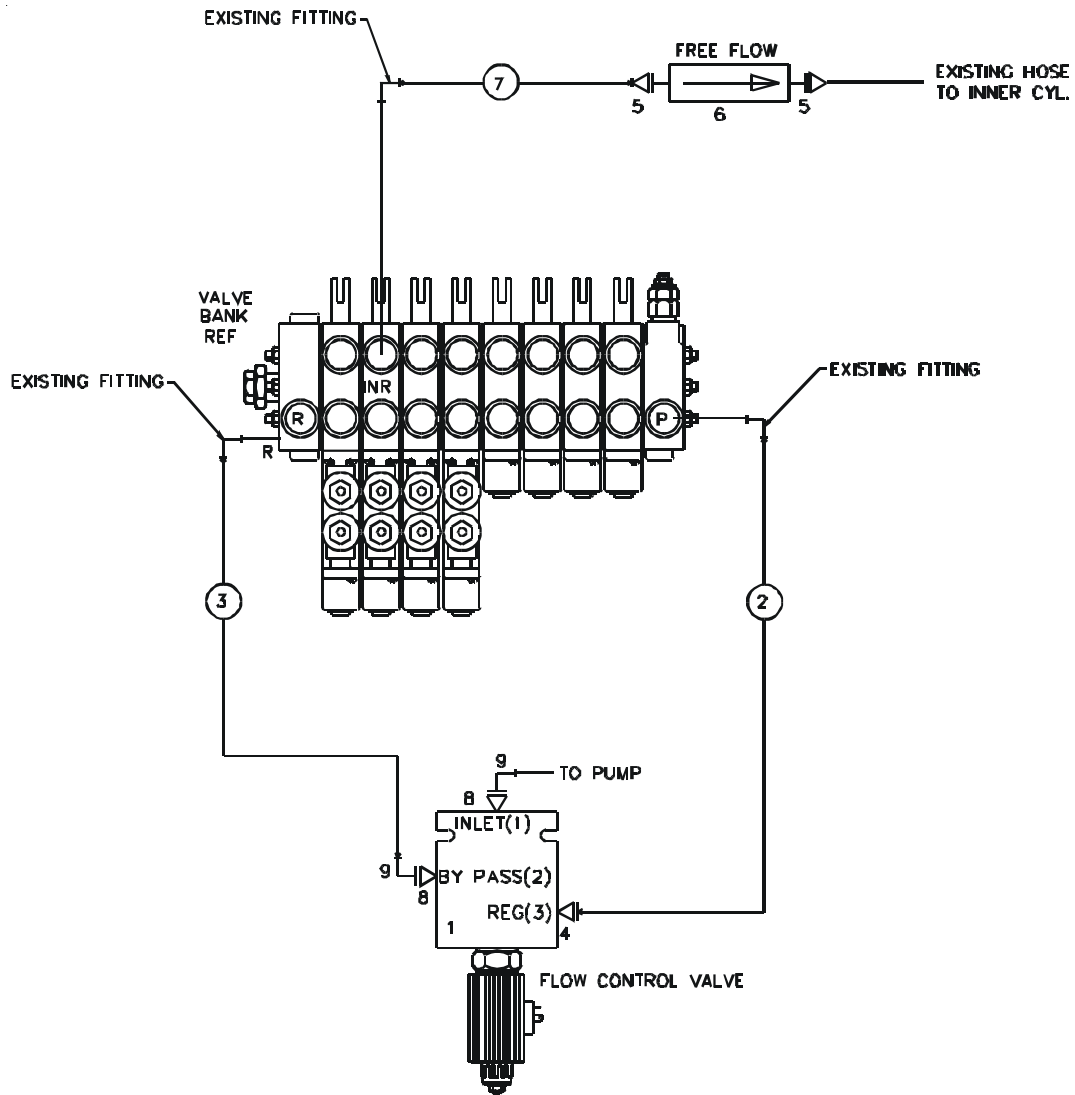

PROP'L RMT HANDLE ASM (51713429)

ITEM	PART NO.	DESCRIPTION	QTY
1.	60045031	WIRE 18GA X 4 GRN	8
2.	60119335	CONTROL HANDLE BACK	1
3.	60111141	TRIGGER	1
4.	60119277	COVER	1
5.	70034306	BACK COVER	1
6.	70029119	SERIAL NUMBER PLACARD	1
8.	77044621	PIN	23
9.	70392862	DECAL-DGR RC ELECTRO	1
10.	71394282	DECAL-RC HANDLE	1
11.	51707507	POTENTIOMETER ASM(INCL:22)	1
12.	72066340	POP RIVET	2
14.	72061009	SHT MTL SCR #6X3/4 PH	8
15.	77040051	TERM #8 SPRSPD 16-14GA	25
16.	77040371	TOGGLE SWITCH SPST	1
17.	77040372	TOGGLE SWITCH SPDT	6
18.	77040373	TOGGLE SWITCH SPST	2
20.	77044579	CONNECTOR	1
21.	89044100	CABLE 18GA/24WIRE X 45FT	1
22.	77040047	TERM MSLPON(PART OF 11)	3REF
23.	77040186	TERM 1/4 FSLPON 16-14GA	3
24.	60111142	MTG BRACKET	1
25.	72060669	CAP SCR #10-32X5/8 SH	1
26.	72060636	CAP SCR #10-24X3/4 SH	2
27.	72062106	NUT #10-24 LOCK	2
28.	70143223	SPRING	1
29.	72061000	SHT MTL SCR #6X1/2 PH	1
30.	77044196	CONNECTOR	1

TETHERED PROPORTIONAL REMOTE POTENTIOMETER ADJUSTMENT

NOTES: ONLY use this procedure to set the low-end output on the remote handle assembly if crane functions operate without pulling the proportional trigger. You may need a second operator to help with steps 4 and 5.

1. Following proper crane and stabilizer set-up, with the PTO engaged and the truck running, move the crane from the stowed position to a position off to the side of the truck. Unstow the winch cable hook and lower the winch approx (6) six feet.
2. Remove the back cover of the remote control handle.
3. Loosen screw "A" slightly. (Note: Screw style may vary).
4. While holding "WINCH DOWN" function, very slowly, rotate screw "B" clockwise until all movement has stopped.
5. Release "WINCH DOWN" function.
6. Tighten screw "A"
7. Test by operating "WINCH DOWN", "WINCH UP", "ROTATE CCW", and "ROTATE CW" without pulling the trigger. If any of these functions move, repeat steps 2 through 6.
8. Replace control back cover and properly stow the crane and stabilizers.

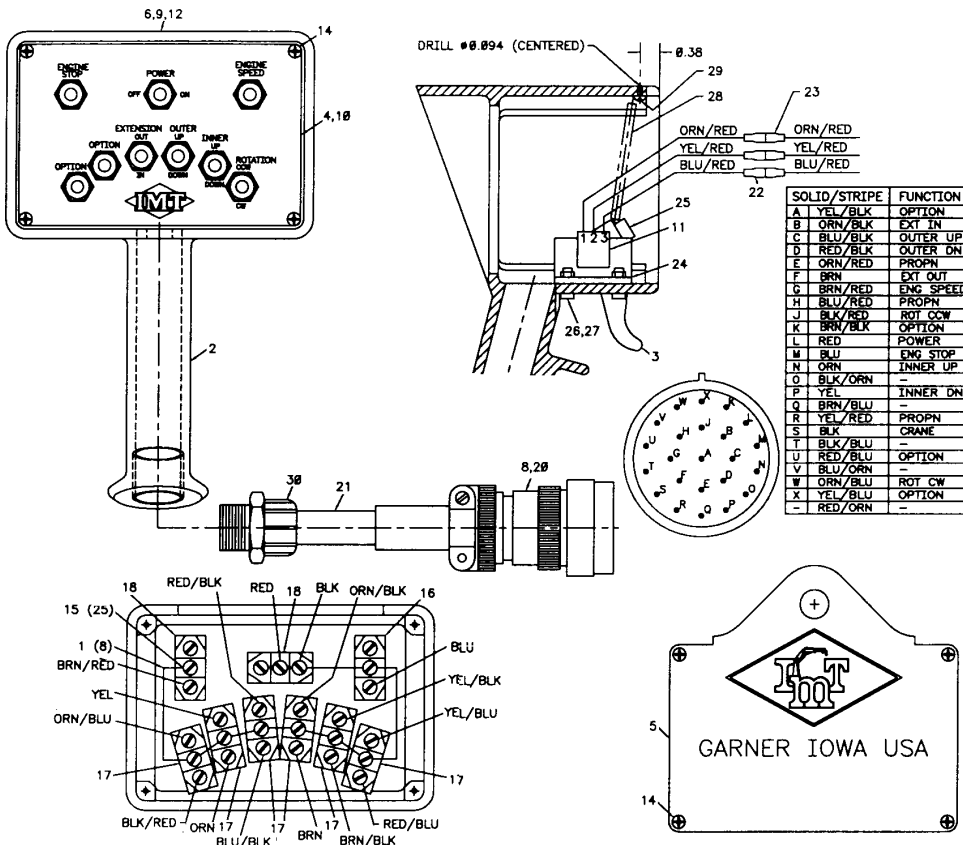
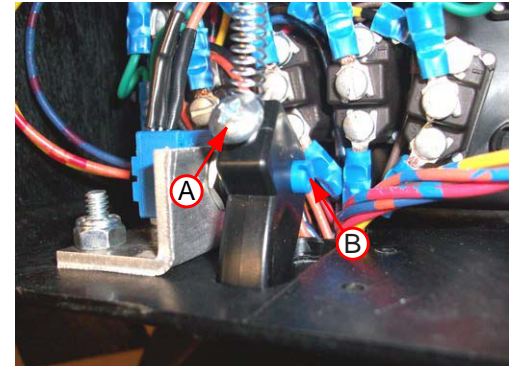

CABLE ASM-JIC BOX 94" (51713568)

ITEM	PART NO.	DESCRIPTION	QTY
1.	89044100	CABLE 18GA/24WIRE X 94	1
2.	90713575	JIC BOX	1
3.	77041345	TOGGLE SWITCH ST	2
4.	77041354	TOGGLE SWITCH DT	1
5.	77044018	STRAIN RELIEF 1/2	2
6.	77044201	NUT 1/2 ELEC LOCK	3
7.	77044196	STRAIN RELIEF 3/4	1
8.	77044202	NUT 3/4 ELEC LOCK	1
9.	77044468	STRAIN RELIEF 1/2	1
10.	77040186	TERM 1/4 FSLPON 16-14GA	25
11.	77040282	TERM 1/4 PIGBAC 16-14GA	3

12.	77040051	TERM #8 SPRSPD 16-14GA	4
13.	77044620	CONNECTOR	1
14.	77044580	SOCKET	23
15.	70393257	DECAL-JIC BOX	1
16.	77044341	TERMINAL BLOCK-4	1
17.	77041056	FUSE 20A IN-LINE	1
18.	77040048	BUTT CONNECTOR 16-14GA	4
19.	89044232	WIRE 14GA RED X 3	2
20.	77044668	PLUG-SEAL	1
21.	89044354	CABLE 14GA/6WIR	84"
22.	77041423	DIODE	1
23.	77044667	PLUG-CAP	1

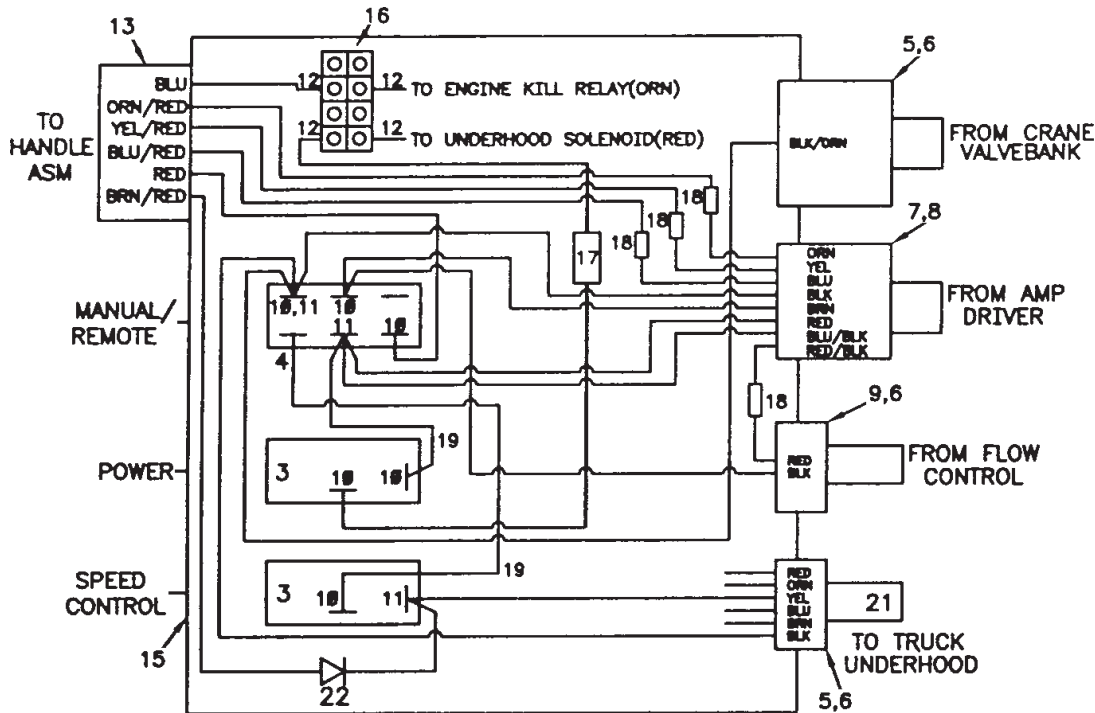

SOLID/STRIPE	TERM	ITEM NO
A	YEL/BLK	10
B	ORN/BLK	10
C	BLU/BLK	10
D	RED/BLK	10
E	ORN/RED	10
F	BRN	10
G	BRN/RED	10
H	BLU/RED	10
J	BLK/RED	10
K	BRN/BLK	10
L	RED	10
M	BLU	12
N	ORN	10
O	20	-
P	YEL	10
Q	BRN/BLU	-
R	YEL/RED	10
S	BLK	10
T	BLK/BLU	-
U	RED/BLU	10
V	BLU/ORN	-
W	ORN/BLU	10
X	YEL/BLU	10
-	RED/ORN	-

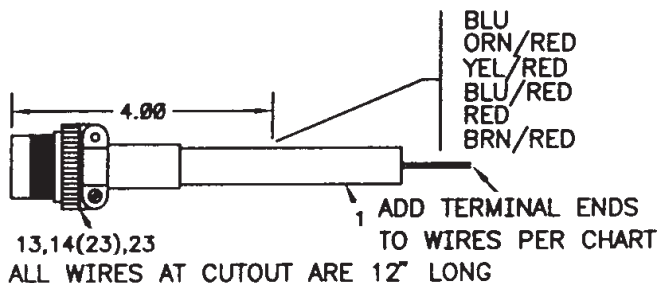
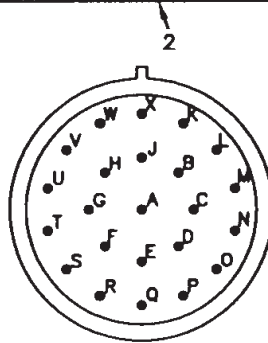

**OPTION-WINCH KIT (31717776)
USED THROUGH S/N 5200R101026**

2.	52703575	MTG. BRACKET	1REF*
3.	72060199	SCREW, CAP 3/4-10 X 9 HHGR5	2REF*
4.	72062114	LOCK NUT 3/4-10	2REF*
5.	60010869	STUD 1/2-13 X 4.5	4REF*
6.	60010868	SPACER	2REF*
7.	71057607	WINCH (INCL. #30)	1REF*
8.	72063053	LOCKWASHER 1/2	6REF*
9.	72060797	SCREW, CAP 1/2-13 X 2.5 SH	2REF*
10.	72062004	NUT 1/2-13	4REF*
11.	71039096	KNOB	2
12.	72066168	COTTER PIN .09 X 3/4	3
13.	72661169	PIN 5/16 X 3/4	1
14.	72066338	PIN, CLEVIS 5/16 X 1.00	2
15.	72053497	ADPTR 1/2MPT 3/4MJIC	2REF*
16.	52704745	MALE CONTROL ROD	2
17.	52704744	FEMALE CONTROL ROD	1
18.	70029451	CONTROL HANDLE	2

19.	51396269	HOSE-FF 3/8 X 264 OAL (6-8)	2
20.	72053760	ELBOW 9/16MSTR 9/16MJIC 90°	1
21.	72532700	ELBOW 9/16 MSTR 9/16MJIC XLG	1
23.	73054006	CHECK VALVE	1REF*
24.	72532670	ELBOW #8MJIC #8FJIC 45°	2REF*
25.	72053744	ADPTR #10MSTR 1/2FPT	2REF*
26.	72053629	ADPTR 1/2MPT 3/8MPT HEX	1REF*
27.	60101420	TUBE	1REF*
28.	72532138	BUSHING, RED 3/8MPT-1/4FPT	1REF*
29.	72063030	MACH BUSHING 3/4X10 GA	8REF*
30.	72060598	SET SCREW 1/2-13 X 3/4 SH (PART OF #7)	1REF
31.	31904002	WINCH KIT (INCL. *S - 2-10,14,23-29,32,33)	1
32.	72533342	FLRLS TUBE 45° MPT #4 1/4	2REF*
33.	72053611	TEE 3/8 NPT	1REF*

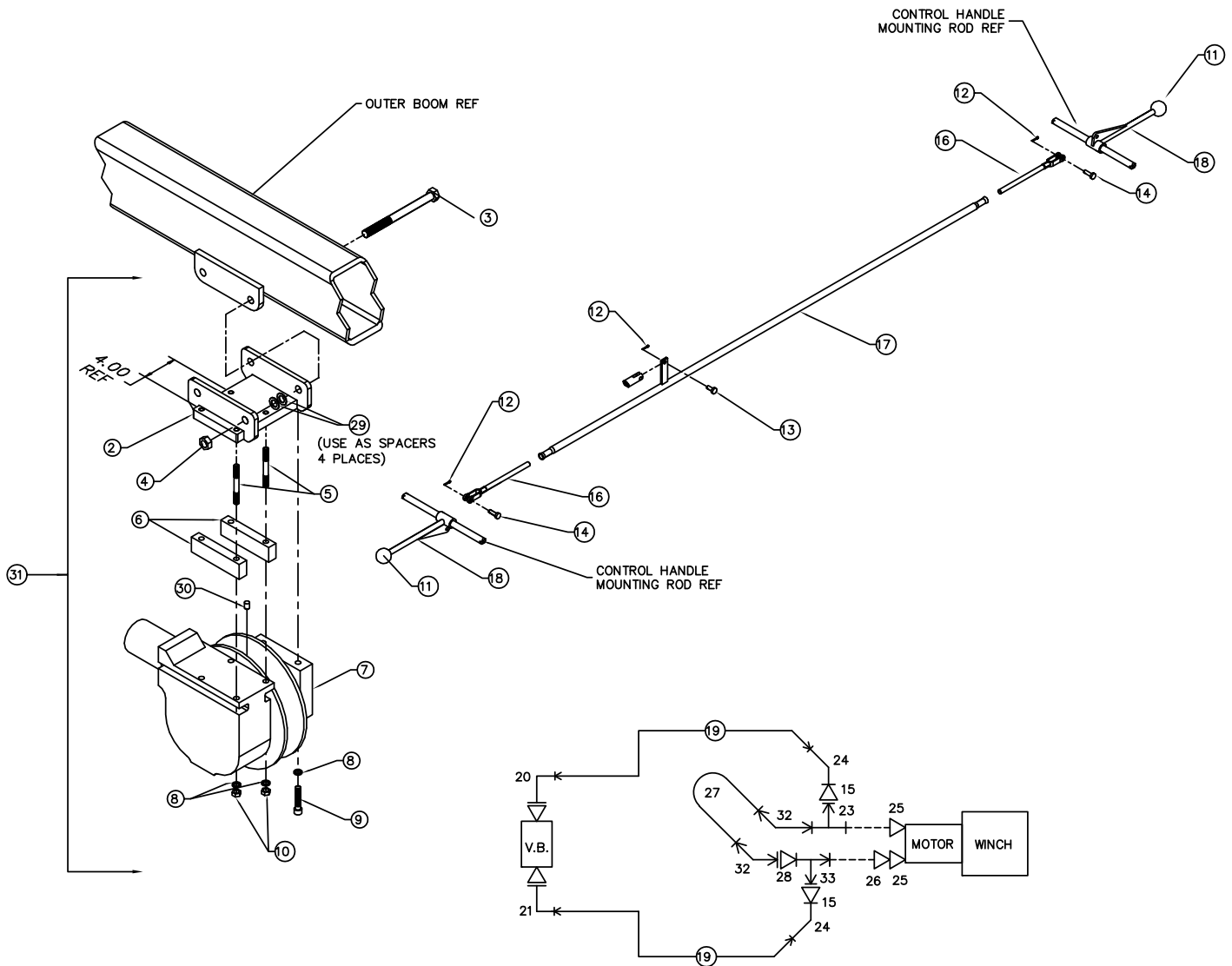

OPTION-CABLE & HOOK KIT (31705637)

ITEM	PART NO.	DESCRIPTION	QTY
1.	52070705	PIN	1
2.	52704143	YOKE	1
3.	60107592	CABLE 3/8X65'	1
4.	70034204	SHEAVE 10-1/4 NYLON	1
5.	70055024	BEARING	1
6.	70055025	RACE	1
7.	70058033	CABLE CLAMP 3/8	1
8.	70731716	SWVL HOOK W/WEDGE SOCKET	1
9.	72053508	ZERK 1/8NPT	1
10.	72066145	HAIR PIN	2
11.	52070151	PIN	1

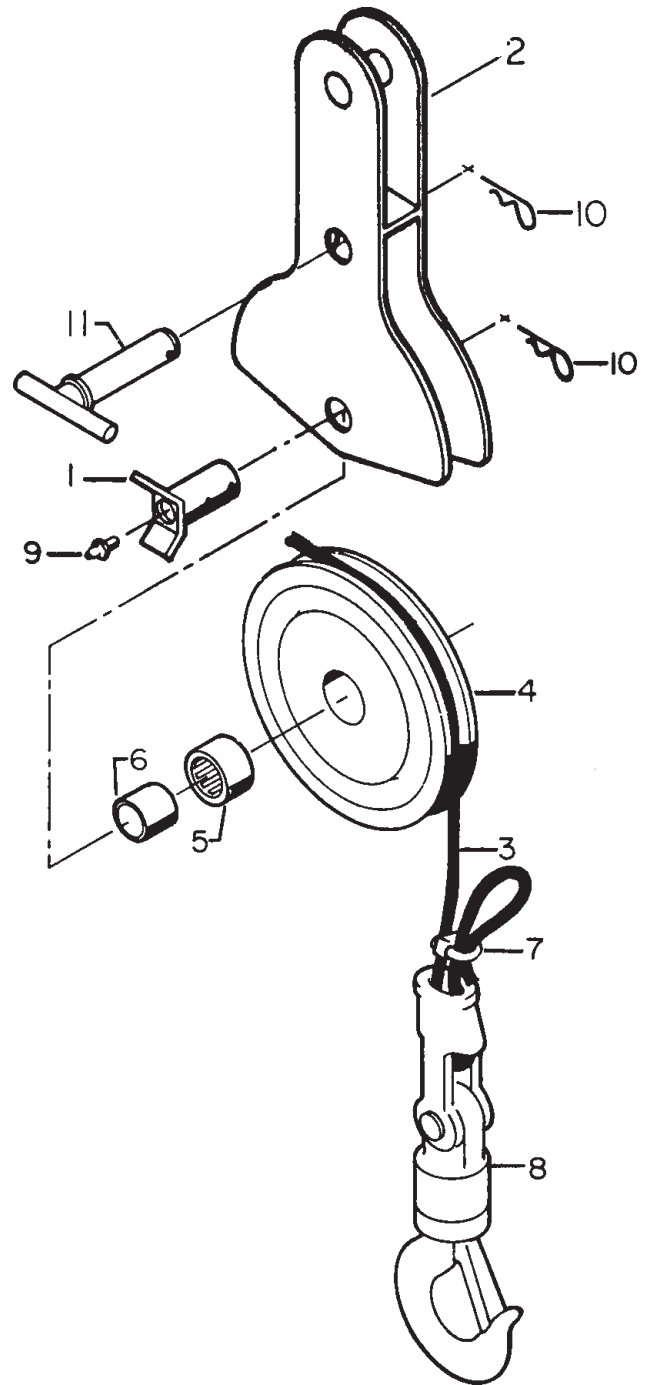

TWO-BLOCK DAMAGE PREVENTION KIT (51724350 / DWG 99905344)

ITEM	PART NO.	DESCRIPTION	QTY
1.	51724375	YOKE-TWO-BLK DMG PREVASM	1
2.	72661693	BLOCK-TPD .25-20X .44X 0.91DIA	5
3.	51724374	CORD REEL ASM	1
4.	70034381	SUPPORT	3
5.	72060006	CAP SCR .25-20X 1.50 HH GR5 Z	3
6.	72060000	CAP SCR .25-20X .50 HH GR5 Z	3
7.	72063001	WASHER .25 FLAT	3
8.	72063049	WASHER .25 LOCK	3
9.	60107237	BLOCK-TPD .25-20 X 1 X 1 X .5	1
10.	60138820	BRACKET	1

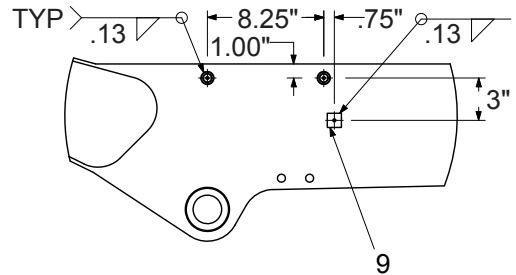
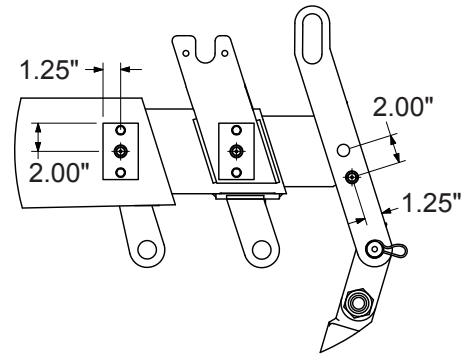
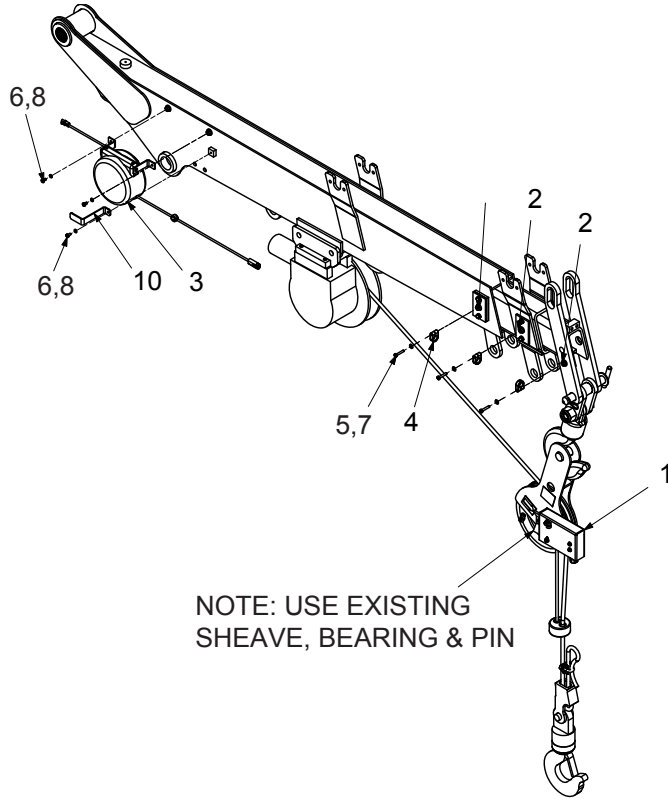

OPTION-HYD OVERLOAD KIT 3F (51717127)

1.	72532657	TEE 3/4JIC SWVL NUT RUN	1
2.	72532658	ELBOW #8MJIC #8FJIC	1
3.	73540085	VALVE BLOCKASM	1
4.	72532358	ADAPTER #8MSTR #8MJIC	5
5.	73054426	RELIEF VALVE - ADJ	1
6.	72533374	TEE #4JIC SWVL NUT RUN	2
7.	72532950	TEE 1-1/16JIC SWVL NUT RUN	1
8.	72532696	ELBOW #12MJIC #12FJIC SWVL	1
9.	72532972	ADAPTER #8MJIC #12FJIC	1
10.	72532772	ELBOW #6MJIC #6FJIC SWVL	2
11.	72532679	PLUG JIC HEX HD STL 3/4	3
12.	51395154	HOSE ASM 3/8X51 FF	2
13.	51394546	HOSE ASM 3/8X51 FF	1
14.	51395153	HOSE ASM 1/2X8 FF	1
15.	72060034	CAP SCR 5/16-18 X 3.25 HH GR5	3
16.	72062109	NUT 5/16-18 HEX NYLOC	3
17.	72532360	ADPTR #12MSTR #8MJIC	1
18.	77441025	OVERLOAD HARNESS	1

NOTES:

1. Function of system is such that when the inner cylinders are overloaded, the pressure switch, mounted on the inner cylinder, will activate the solenoid dump valve(s); thus dumping oil to "tank" instead of the outer cylinder "extend", extension cylinder "extend", or winch "up" functions. This system is based on the fact that the oil will take the path of least resistance.

2. The following functions will shut down if overloaded:

- a. Outer boom "extend"
- b. Extension cylinder "extend"
- c. Winch "up"

3. Install a relief (#73054426, 700 psi) in the extend line of the extension cylinder so cylinder will not extend when the dump system is activated.

4. Use kit in conjunction with electric capacity alert kit.

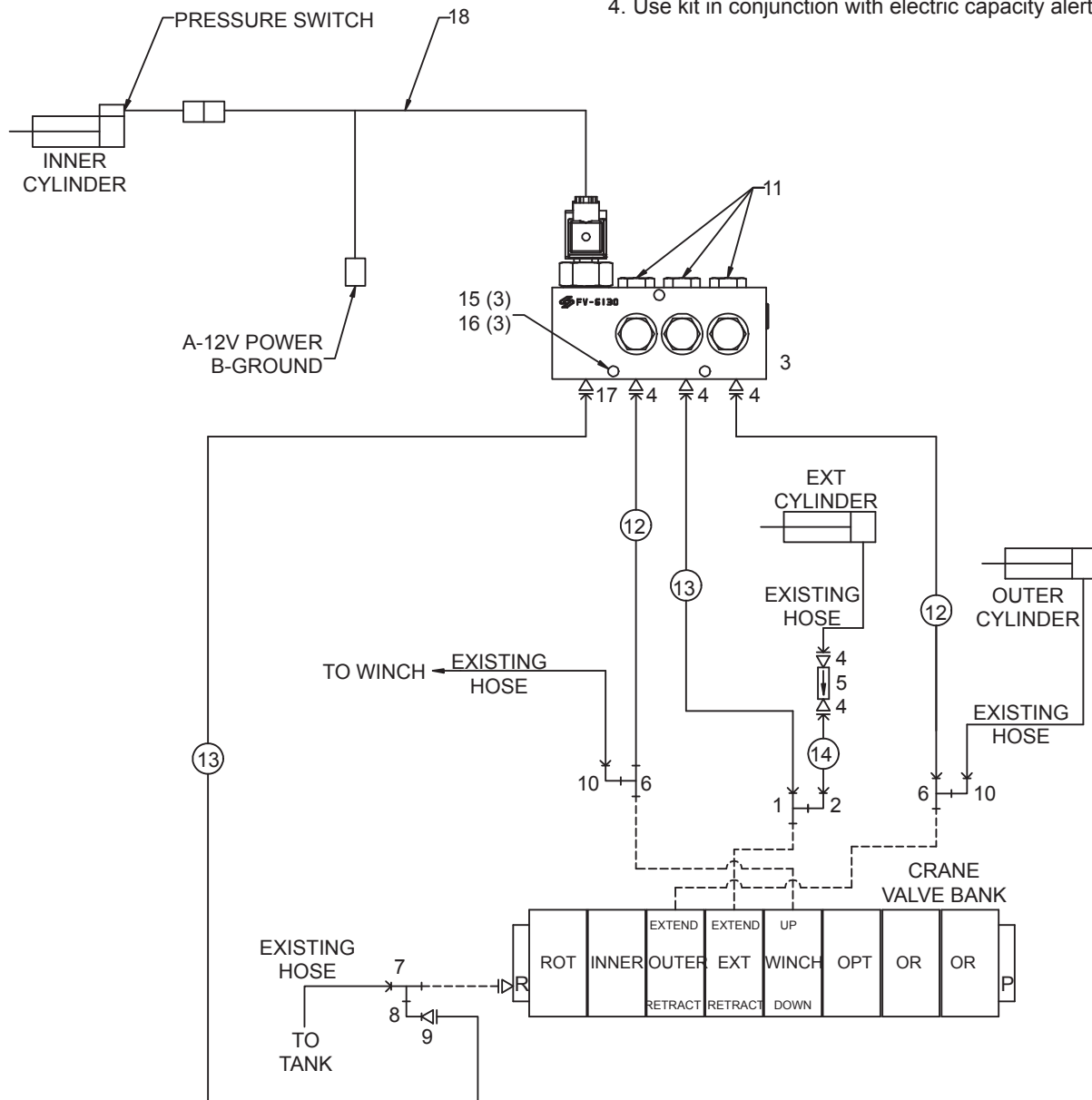

CAPACITY ALERT KIT - 3100 (31713333)

- | | | | |
|----|----------|-------------------------|---|
| 1. | 77041476 | PRESSURE SWITCH | 1 |
| 2. | 7Q072015 | O-RING | 1 |
| 3. | 72532140 | PLUG 9/16-18 STR THD HH | 1 |
| 4. | 60025221 | MANIFOLD | 1 |
| 5. | 72060731 | CAP SCR 5/16-18X 3/4 SH | 4 |

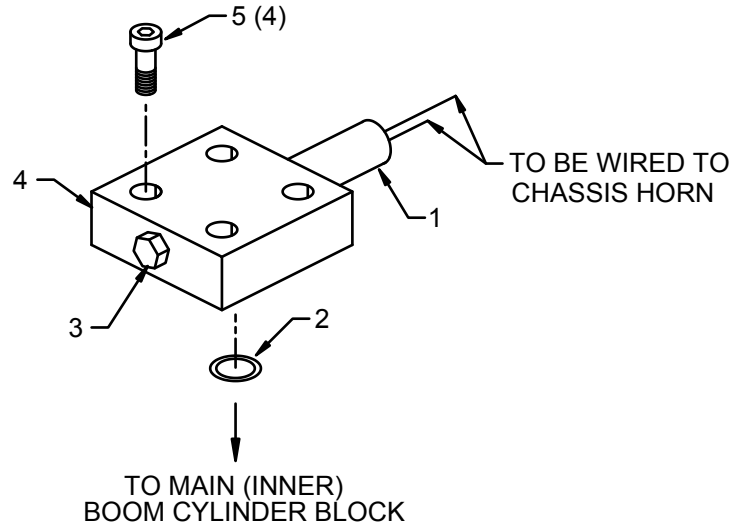

CAPACITY SHUTDOWN KIT - 3100 PSI (31717516)

- | | | | |
|----|----------|---------------------------|---|
| 1. | 77041625 | PRESSURE SWITCH | 1 |
| 2. | 7Q072015 | O-RING | 1 |
| 3. | 72532140 | PLUG 9/16 STR HH STL | 1 |
| 4. | 60025221 | MANIFOLD | 1 |
| 5. | 72060731 | CAP SCR 5/16-18 X 3/4 SHZ | 4 |

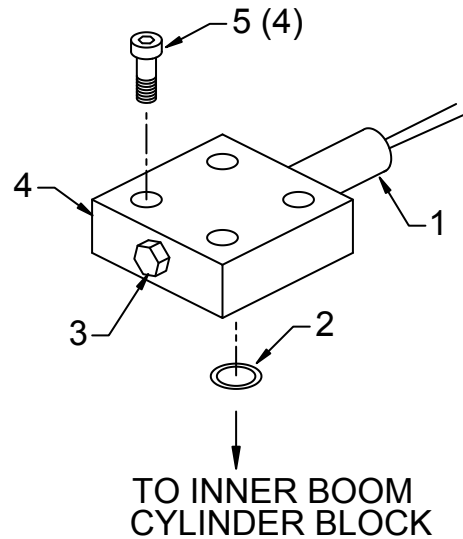

OPTION-AUGER MTG KIT (51707059)

ITEM	PART NO.	DESCRIPTION	QTY
1.	51705062	HOSE ASM 1/2X48 FF	2
2.	60108961	SWIVEL LINK-AUGER	1
3.	72533101	DISCONNECT COUPLER 3/8FPT	1
4.	72533102	DISCONNECT NIPPLE 3/8FPT	1
5.	72053670	ADAPTER 3/8MPT 3/4MJIC	4

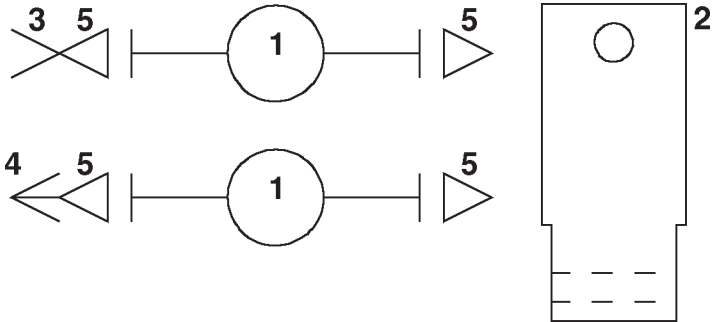

**OPTION -AUGER HOSE REEL KIT-V20
(51707805)**

ITEM	PART NO.	DESCRIPTION	QTY
1.	51704918	HOSE ASM 1/2X282 FF	2
2.	51703664	HOSE ASM 1/2X228 FF	1
3.	60025240	CONTROL HANDLE	1
4.	70029451	CONTROL HANDLE	1
5.	52702016	CONTROL ROD F	1
6.	52702018	CONTROL ROD M	1
7.	60118684	BULKHEAD PLATE	1
8.	72060157	CAP SCR 5/8-11X4-1/2 HH GR8	1
9.	72062091	NUT 5/8-11 LOCK	1
10.	70731877	HOSE REEL	2
11.	71039096	KNOB	1
12.	72053497	ADAPTER 1/2MPY 3/4MJIC	4
13.	72533101	DISCONNECT COUPLER 3/8FPT	1
14.	72533102	DISCONNECT NIPPLE 3/8FPT	1
15.	60111589	VB MTG PLATE	1
16.	72053670	ADAPTER 3/8MPT 3/4MJIC	2

17.	60111573	GUSSET	2
18.	72060047	CAP SCR 3/8-16X1-1/4 HH GR5	8
19.	72060093	CAP SCR 1/2-13X1-1/2 HH GR5	4
20.	72062103	NUT 3/8-16 LOCK	8
21.	72063001	WASHER 1/4 WRT	4
22.	72063003	WASHER 3/8 WRT	8
23.	72063053	WASHER 1/2 LOCK	4
24.	72066168	COTTER PIN 3/32X3/4	2
25.	72066338	CLEVIS PIN 5/16X1	2
26.	72532666	ELBOW 3/4MSTR 3/4MJIC XLG	2
27.	60030069	SPACER 5/8X1X1-3/4	1
28.	94731839	LINK & PIN KIT	1
30.	60111412	HOSE REEL MTG BRACKET	1
32.	51707856	VALVEBANK V20 1-SECTION	1
34.	99900183	VB MTG MODIFICATION DWG	1
35.	72060033	CAP SCR 5/16-18X3 HH GR5	3
36.	72063002	WASHER 5/16 WRT	3
37.	72062109	NUT 5/16-18 LOCK	3

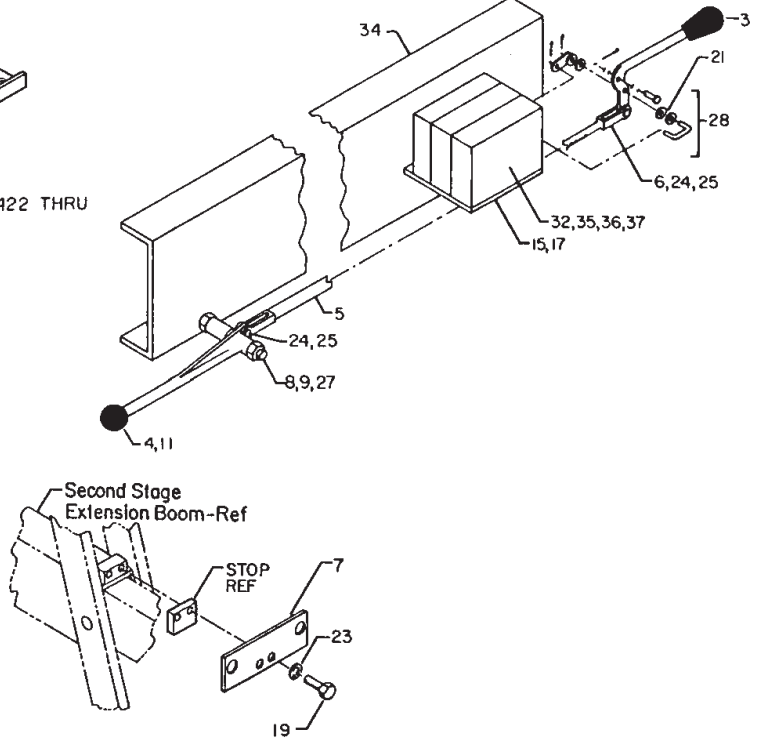
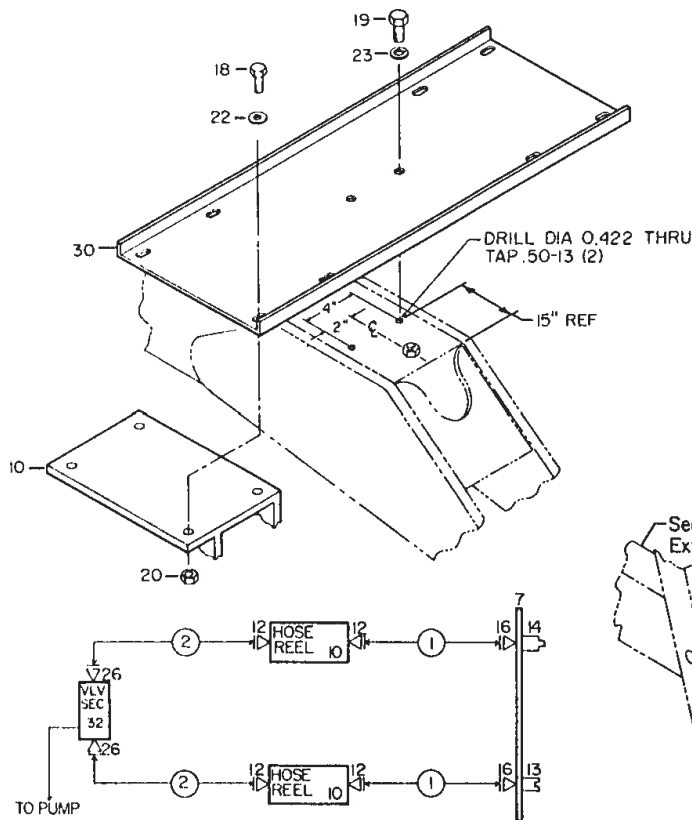

**OPTION-AUX RESERVOIR-30GAL
(31701760)**

ITEM	PART NO.	DESCRIPTION	QTY
1.	52701550	RESERVOIR	1
2.	73141276	STRAINER	1
3.	73014671	FILL CAP	1
4.	72060093	CAP SCR 1/2-13X1-1/2 HHGR5	4
5.	72063053	WASHER 1/2 LOCK	4
6.	72062004	NUT 1/2-13 HEX	4

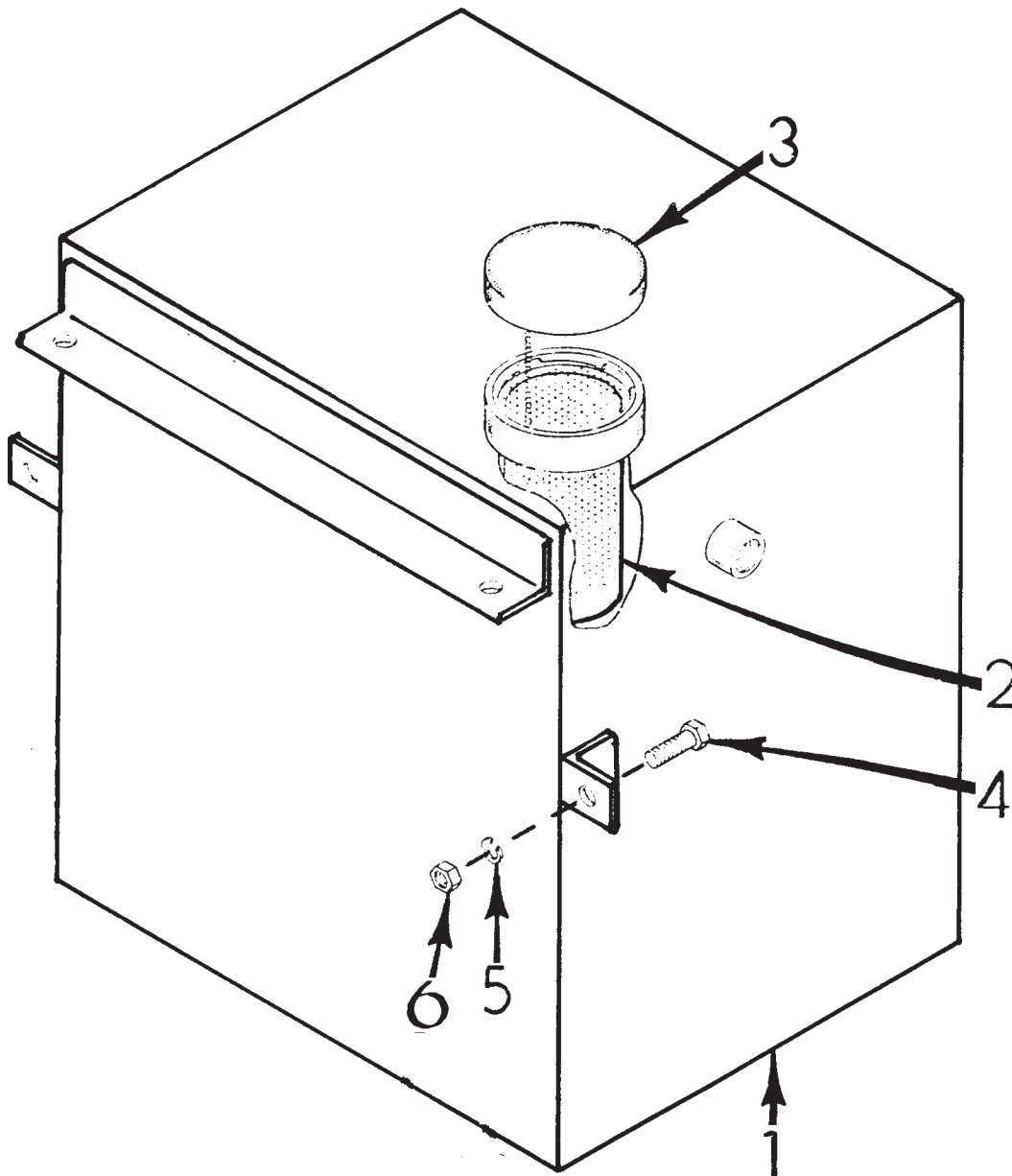

OPTION-SGL HOSE REEL KIT (31712487)

ITEM	PART NO.	DESCRIPTION	QTY
2.	70732864	HOSE REEL-RH	1
3.	51393812	HOSE ASM 1/4X300 TWIN FF	1
4.	60117715	HOSE REEL MTG BRACKET	1
5.	72533380	DISCONNECT COUPLER 1/4NPT	1
6.	72533382	DISCONNECT NIPPLE 1/4NPT	1
7.	72533381	CAP	2
8.	72532353	ADAPTER #6MSTR #4MJIC	4
9.	60115137	ANGLE	1
10.	72060097	CAP SCR 1/2-13X3 HHGR5	2
11.	72060093	CAP SCR 1/2-13X1-1/2 HHGR5	2

12.	72062080	NUT 1/2-13 LOCK	4
13.	72053499	ADAPTER 1/4MPT #4MJIC	2
14.	72063003	WASHER 3/8 WRT	4
16.	72060044	CAP SCR 3/8-16X3/4 HHGR5	2
18.	51708885	HOSE ASM 1/4X229 FF	2
23.	71039096	KNOB	2
24.	70029451	CONTROL HANDLE	2
25.	52704745	CONTROL ROD-M	2
26.	52704744	CONTROL ROD-F	1
27.	72066338	CLEVIS PIN 5/16X1	3
28.	72066168	COTTER PIN .09X.75	3

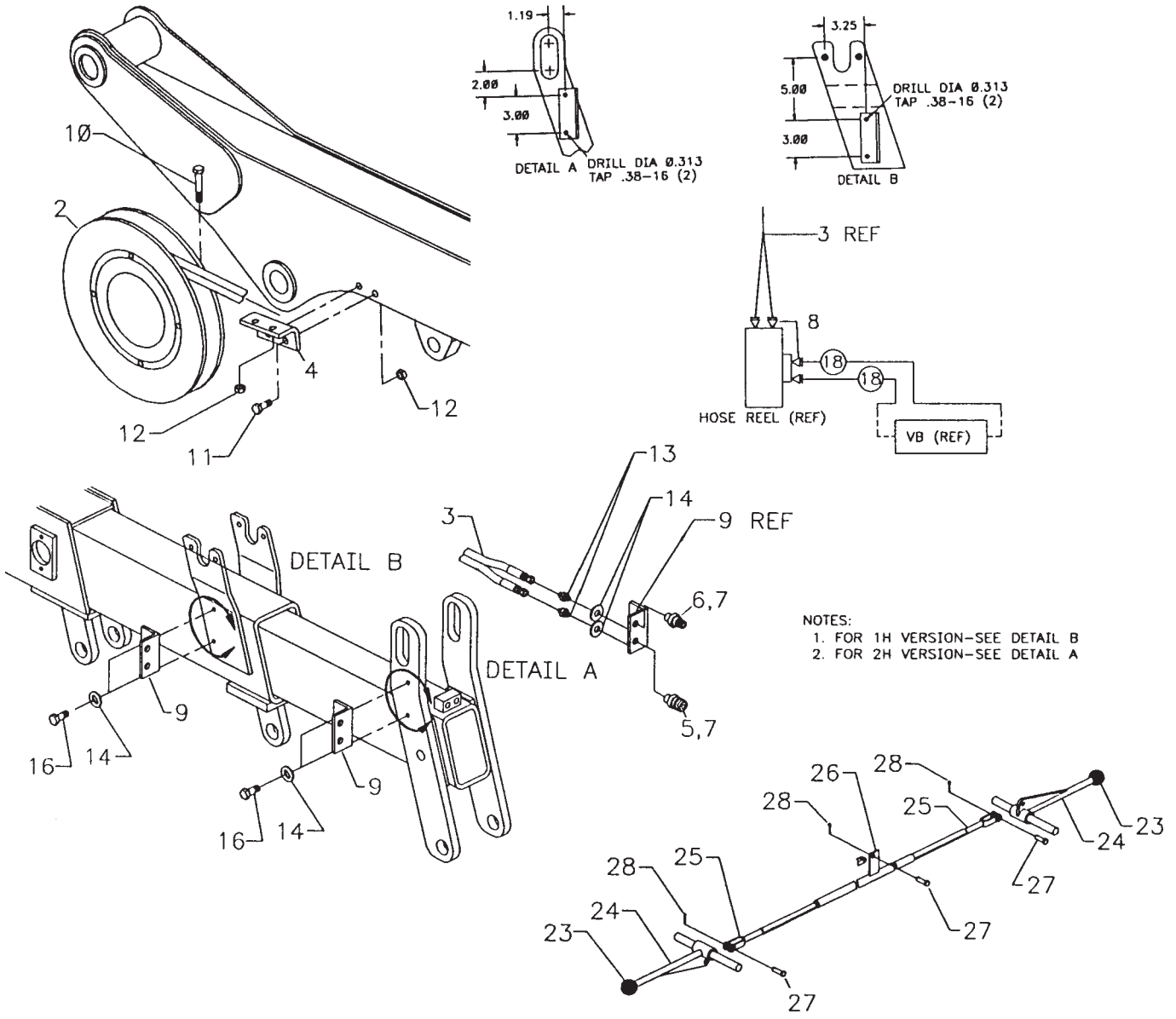

OPTION - LIGHT KIT (31717218)

ITEM	PART NO.	DESCRIPTION	QTY
1.	51717219	CABLE ASM- FLOOD LIGHTS	1
2.	60107762	GUARD	1
3.	77040424	FLOOD-LT-COMP WORK LAMP	2
4.	60103535	SWITCH BRACKET - 1 HOLE	1
5.	77041345	TOGGLE SWITCH	1
6.	77044574	CONNECTOR	2
7.	77044550	TERMINAL-F 18-20 GA	2
8.	70394069	SEAL CABLE CONNECTOR	4
9.	72063049	WASHER 1/4 LOCK	2
10.	72063051	WASHER 3/8 LOCK	2
11.	77040000	TERMINAL, RING #10 STUD 16-14	1
12.	89044274	WIRE-BLACK STRD TYPE 36"	36"
13.	72060000	CAP SCR 1/4-20 X 1/2 HH GR5	2
14.	72060044	CAP SCR 3/8-16 X 3/4 HH GR5	2
15.	72062000	NUT 1/4-20 HEX ZINC	

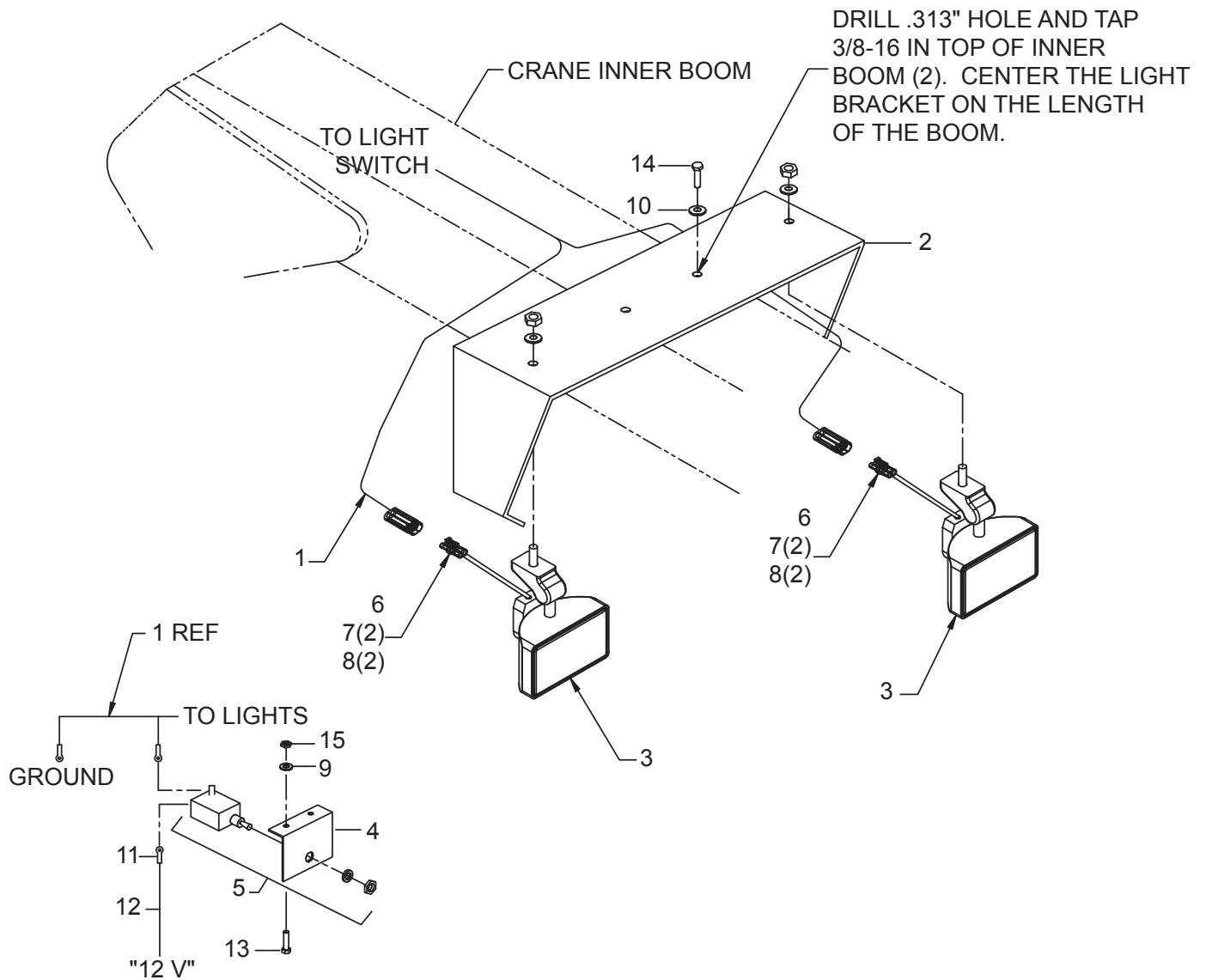

DECAL KIT-MODEL 780 CRANE (95711801-1)

- 1. 70029251 IMT DIAMOND 2
- 2. 70391583 DECAL-SETUP/STOW 2
- 3. 70391612 DECAL-GREASE WEEKLY LH 4
- 4. 70391613 DECAL-GREASE WEEKLY RH 5
- 5. 70392108 DECAL-SUCTION LINE 1
- 6. 70392109 DECAL-RETURN LINE 1
- 7. 70393761 DECAL-780 IDENT 2
- 8. 70392213 DECAL-CAUTION WASH/WAX 1
- 9. 70392524 DECAL-ROTATE/GREASE 1
- 10. 70392813 DECAL-DANGER ELECTRO 2
- 11. 70392814 DECAL-WARNING OPERATOR 2
- 12. 70392815 DECAL-WARNING OPERATION 2
- 13. 70392864 DECAL-WARN STAB STD CLR 2
- 14. 70392865 DECAL-DANGER ELECTRO 4
- 15. 70392866 DECAL-WARN OPER COND 2

- 17. 70392888 DECAL-WARN OPER RESTRICT 2

- 18. 70392890 DECAL-DGR STOW/UNFOLD 2
- 19. 70392891 DECAL-DANGER DRIVELINE 2
- 20. 70392982 DECAL-CONTACT IMT 1
- 21. 71039134 DECAL-CAUTION OIL LEVEL 1
- 22. 71392731 CAPACITY PLACARD 2
- 23. 71392255 DECAL-CTRLS STREETSIDE 1
- 24. 71392256 DECAL-CTRLS CURBSIDE 1
- 25. 71392257 DECAL-STAB PWR DN SS 1
- 26. 71392258 DECAL-STAB PWR DN CS 1
- 27. 71392365 DECAL-ROTATIONALIGNMENT 1
- 28. 70392889 DECAL-DGR RC ELECTRO LG 2
- 29. 70394190 DECAL-CAUTION NOT A STEP 2
- 30. 70394189 PLACARD-OIL REC 1
- 31. 70394443 DECAL-DGR FREEFALLING BM 1REF
- 32. 70392868 DECAL-DANGER CR LOADLINE 4
- 33. 70392863 DECAL-DANGER HOIST PERS 2
- 34. 70395323 DECAL-ASME/ANSI B30.22 1
- 35. 72042097 LEVEL 2

CONTINUED ON FOLLOWING PAGE

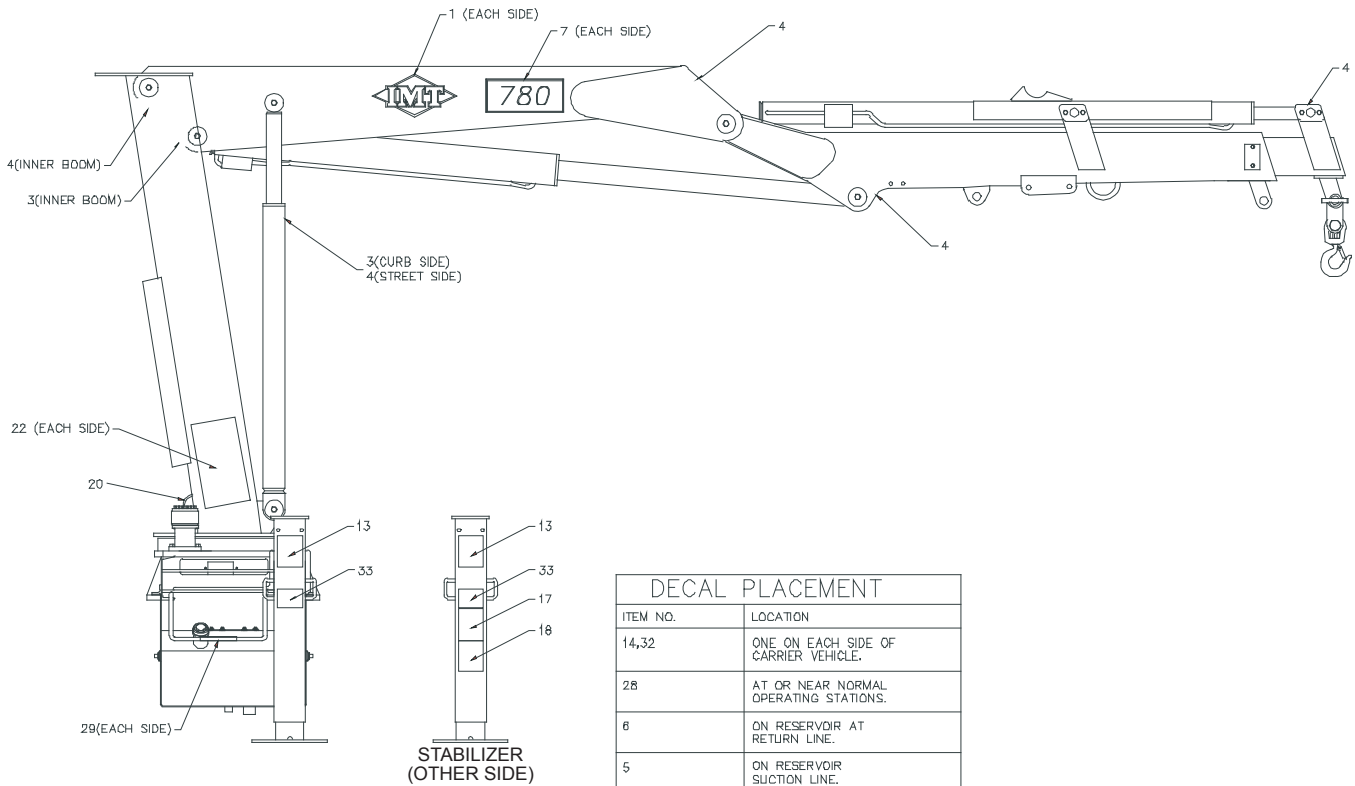

DECAL PLACEMENT	
ITEM NO.	LOCATION
14,32	ONE ON EACH SIDE OF CARRIER VEHICLE.
28	AT OR NEAR NORMAL OPERATING STATIONS.
6	ON RESERVOIR AT RETURN LINE.
5	ON RESERVOIR SUCTION LINE.
19	AT OR NEAR THE DRIVELINE.
31	AT OR NEAR THE MANUAL BOOM EXT. RETENTION MECHANISM.
34	PLACE UNDER SERIAL TAG

NOTE: PLACE ITEM #35, LEVEL, ON FRONT AND SIDE OF CRANE BASE.

DECAL KIT-MODEL 780 CRANE
(95711801-2)

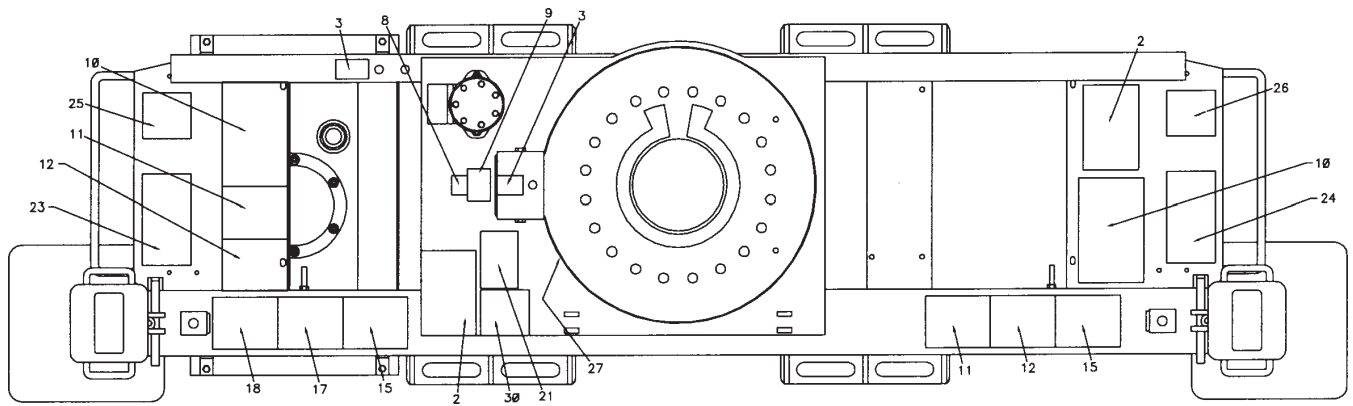

RADIO REMOTE RETROFIT KIT (99903330-1)

1.	73733600	RADIO REMOTE KIT	1
2.	77045894	HARNESS	1
3.	60123676	MOUNTING PLATE	1
4.	51717059	JIC BOX ASM	1
5.	72060005	CAP SCR 1/4-20X1.25	6
6.	72062104	NUT 1/4-20HEX NYLOC ZINC	6
7.	72601761	CAP SCR 6MMX12MMX1.00	4
8.	72601762	WASHER LOCK 6MM	4
10.	73054876	VALVE-PROPN PRIORITY FLOW	1REF
11.	72060051	CAP SCR 3/8-16X2.25	2
12.	72062103	NUT 3/8-16 HEX NYLOC ZINC	2
13.	77041251	RELAY	3
14.	77041237	SOLENOID	1
15.	51704784	CABLE ASM	1

CONTINUED ON NEXT PAGE

EFFECTIVE 09-21-01

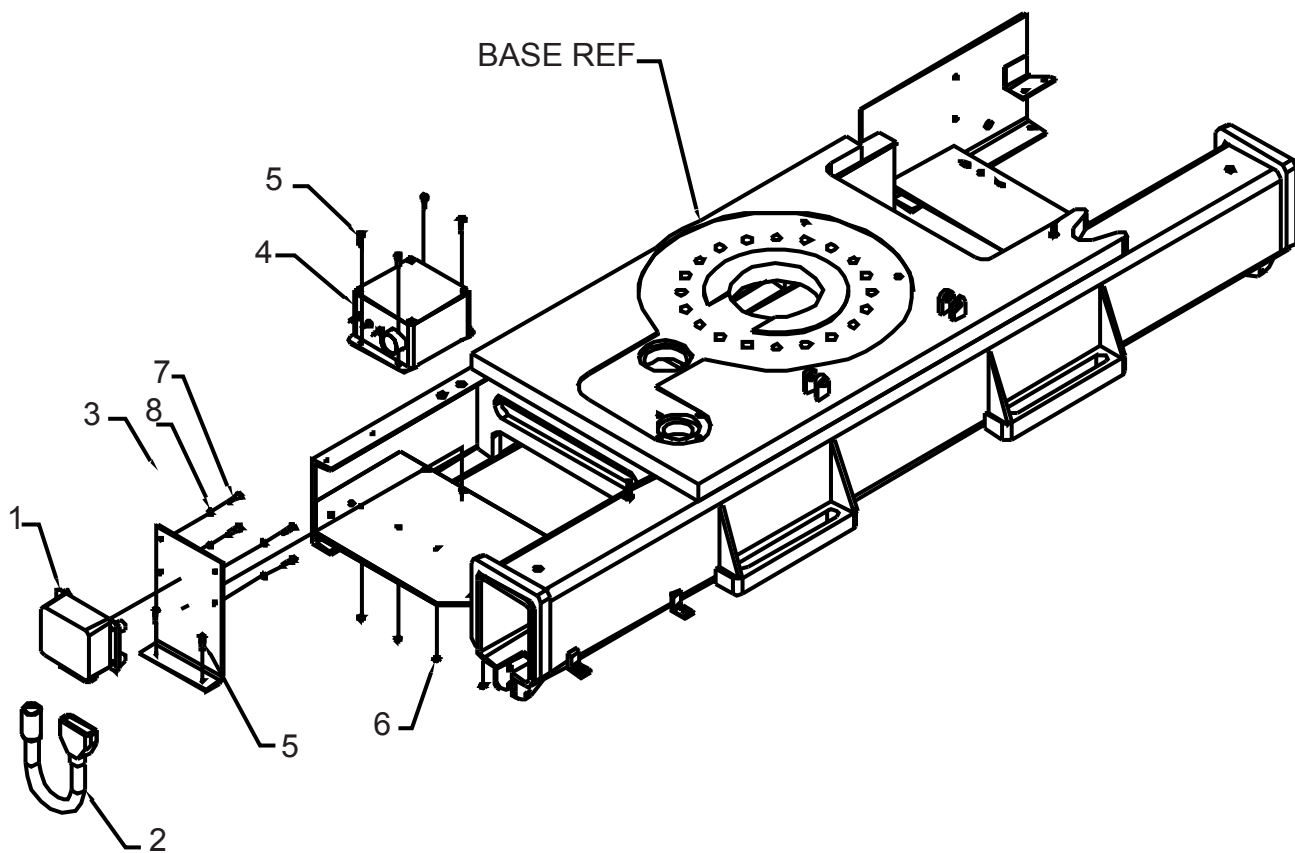

ELEC. SCHEMATIC - RADIO REMOTE RETROFIT (99903330-2)

PARTS LIST ON PREVIOUS PAGE

EFFECTIVE 09-21-01

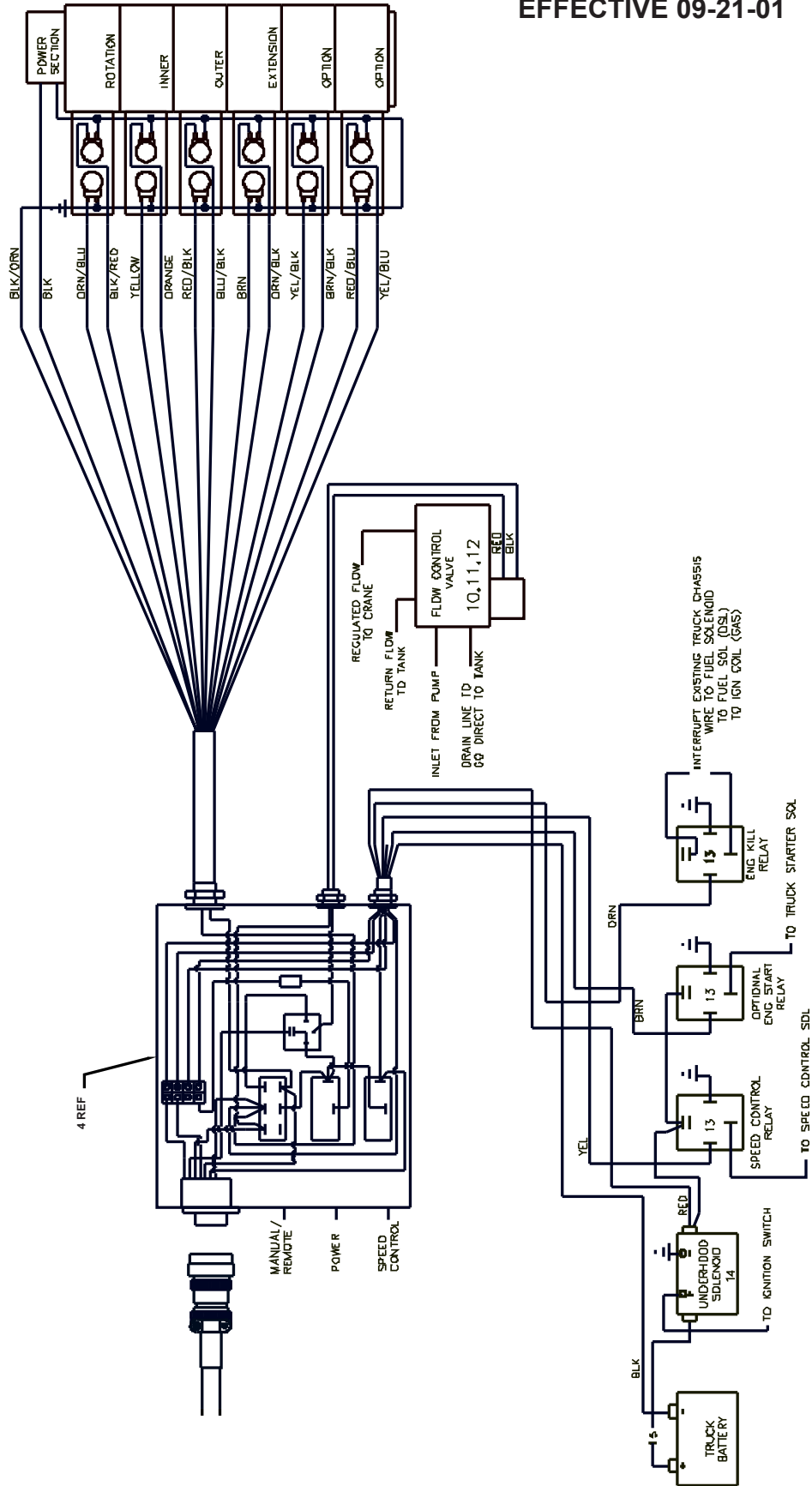

CABLE ASM-18GA/24 WIREX115 (51714624)

ITEM	PART NO.	DESCRIPTION	QTY
1.	77044621	PIN	24
2.	77044579	CONNECTOR	1
3.	89044100	CABLE 18GA/24 WIREX115	1

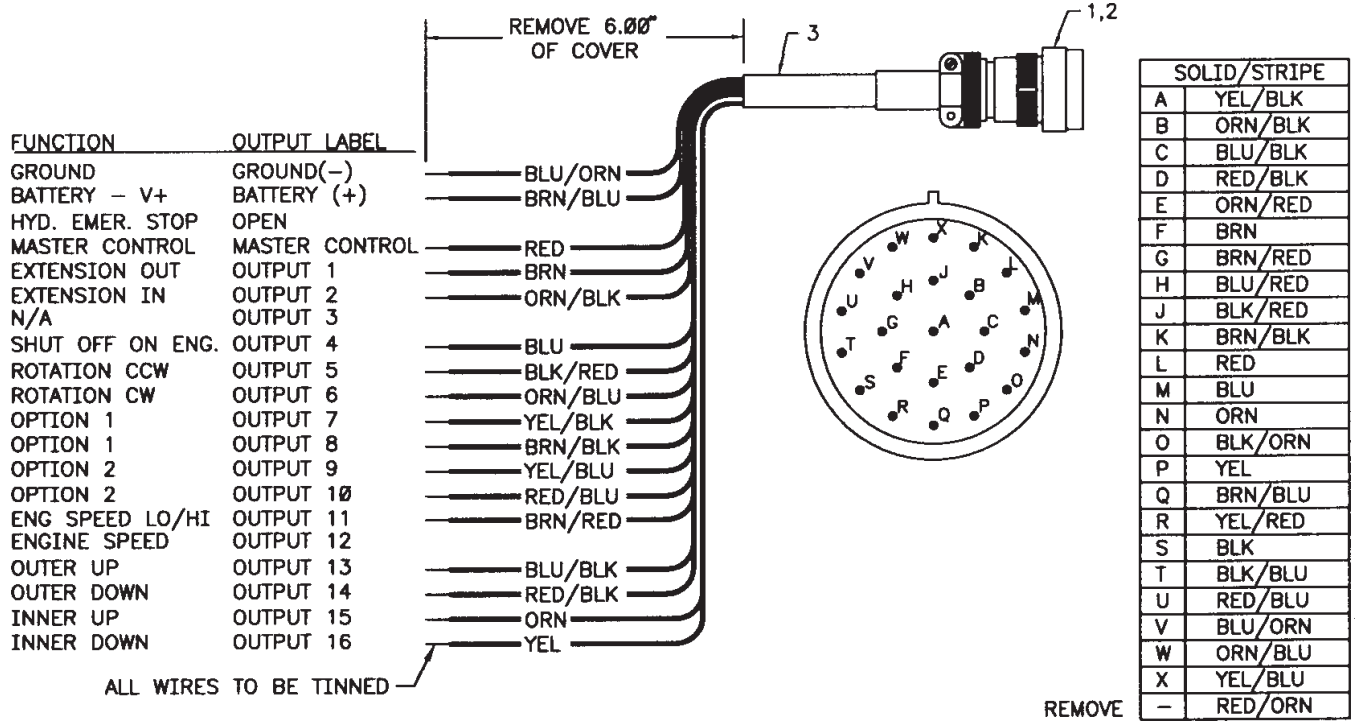

JIC BOX ASM-RADIO REMOTE (51717059)

1.	89044100	CABLE 18GA/24	7.83 FT
2.	90714496	JIC BOXASM 6X6X6	1
3.	77041345	TOGGLE SWITCH (WAS 77041237)2	
4.	77041354	TOGGLE SWITCH	1
5.	77044018	CONNECTOR 1/2 STR RLF	3
6.	77044201	NUT ELEC 1/2 LOCK	3
7.	77044196	CONNECTOR 3/4 STR RLF	1
8.	77044202	NUT ELEC 3/4 LOCK	1
9.	77044620	CONNECTOR	1
10.	77040186	TERMINAL FSLPON 1 .25TAB	14

11.	77040282	TERMINAL PIGBAC	6
12.	77044668	SEAL PLUG	2
13.	77040051	TERMINAL SPRSPADE	6
14.	77044667	CAP PLUG	1
15.	70393257	DECAL 6X6X4 JIC BOX	1
16.	77044341	TERMINAL BLOCK 4 CONTACT	1
17.	77041056	IN-LINE 20 AMP FUSE	1
18.	89044232	WIRE 14GA RED	.5 FT
19.	77044646	WASHER LOCK	1
20.	89044354	CABLE 14GA/6	7 FT
21.	77044468	CONNECTOR 1/2 STR RLF	1
22.	77044645	NUT DEUTSCH	1
23.	77041251	RELAY-12V 30 AMP NOM/ 40AMP MAX	1

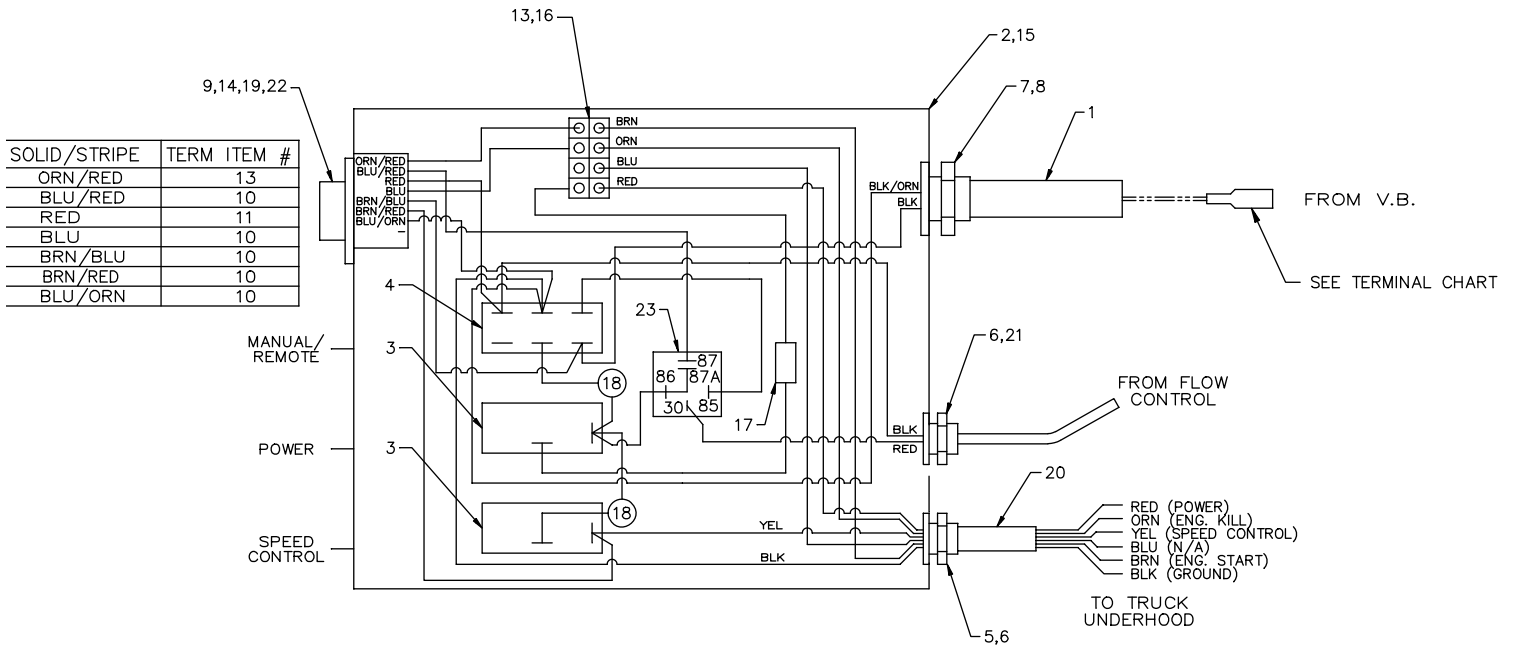

SOLID/STRIPE	TERM ITEM NO
A	YEL/BLK 10
B	ORN/BLK 10
C	BLU/BLK 10
D	RED/BLK 10
E	ORN/RED -
F	BRN 10
G	BRN/RED -
H	BLU/RED -
J	BLK/RED 10
K	BRN/BLK 10
L	RED -
M	BLU -
N	ORN 10
O	BLK/ORG 10
P	YEL 10
Q	BRN/BLU -
R	YEL/RED -
S	BLK 10
T	BLK/BLU -
U	RED/BLU 10
V	BLU/ORN -
W	ORN/BLU 10
X	YEL/BLU 10
-	RED/ORN -

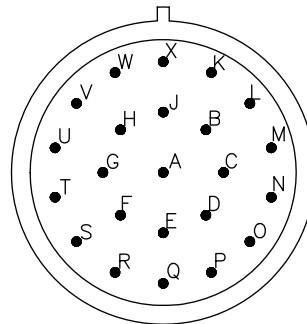

RADIO REMOTE KIT (73733600-1)

CONTINUED ON NEXT PAGE

- 1. 73733588 RADIO RMT RECEIVER 1
- 2. 73733589 RADIO RMT TRANSMITTER 1
- 3. 70146100 BATTERY-VERSA PAK 3.6V 2
- 4. 70146101 BATTERY HOUSING 1
- 5. 70146102 BATTERY CHARGER 1
- 6. 70146103 MAGNET-RADIO RMT TRANSM. 1

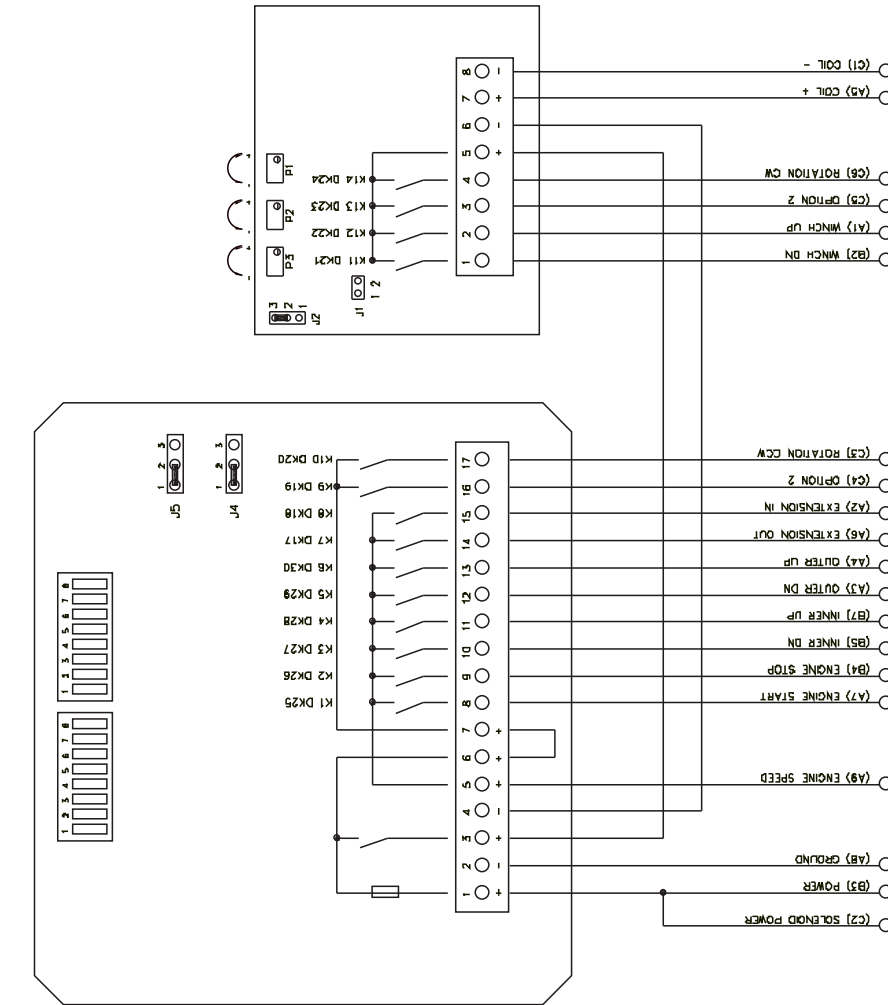

JUMPER CONNECTIONS INSIDE RECEIVER

- J1: PULSE/DITHER FREQUENCY
- NO JUMPER

J2: CONTROL RANGE OF OUTPUT CURRENT
(ONLY CURRENT - CONTROL)
- PIN 2/3 CONNECTED: D-2A

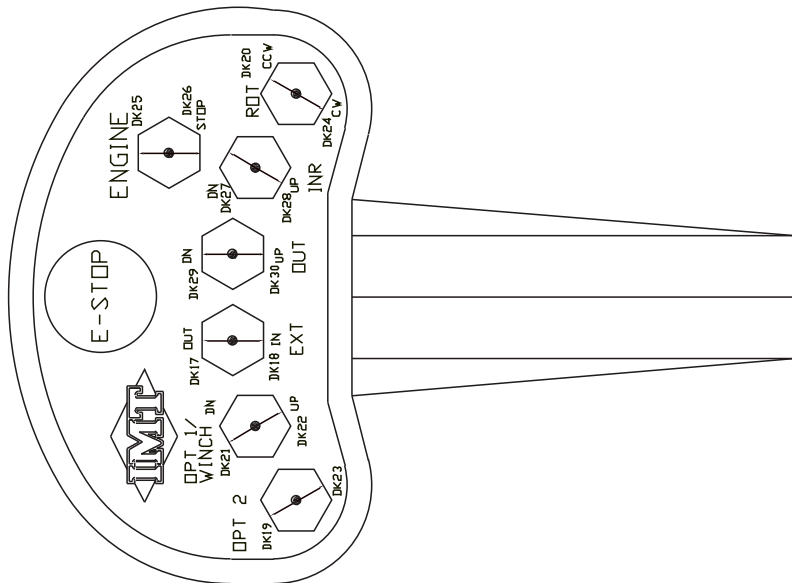

P1: Trimming Potentiometer for Maximum Values
On transmitter handle, engage Rotation CW or CCW function switch and pull trigger fully on. Crane MAY or MAY NOT begin to move at this time due to initial P1 setting. Turn P1 potentiometer counterclockwise until desired maximum speed is obtained or until speed no longer continues to increase.

P2: Trimming Potentiometer for Initial Value Adjustment
On transmitter, engage Rotation CW or CCW function switch. Without pulling trigger, adjust P2 counterclockwise until crane begins to move. At this time, adjust P2 clockwise until no movement is detected. Slightly engage trigger and adjust P2 to fine tune.

P3: Trimming Potentiometer to Adjust Dither Amplitude
Adjust counterclockwise or counterclockwise for smoothness of operation.

RADIO REMOTE KIT (73733600-2)

PARTS LIST ON PREVIOUS PAGE

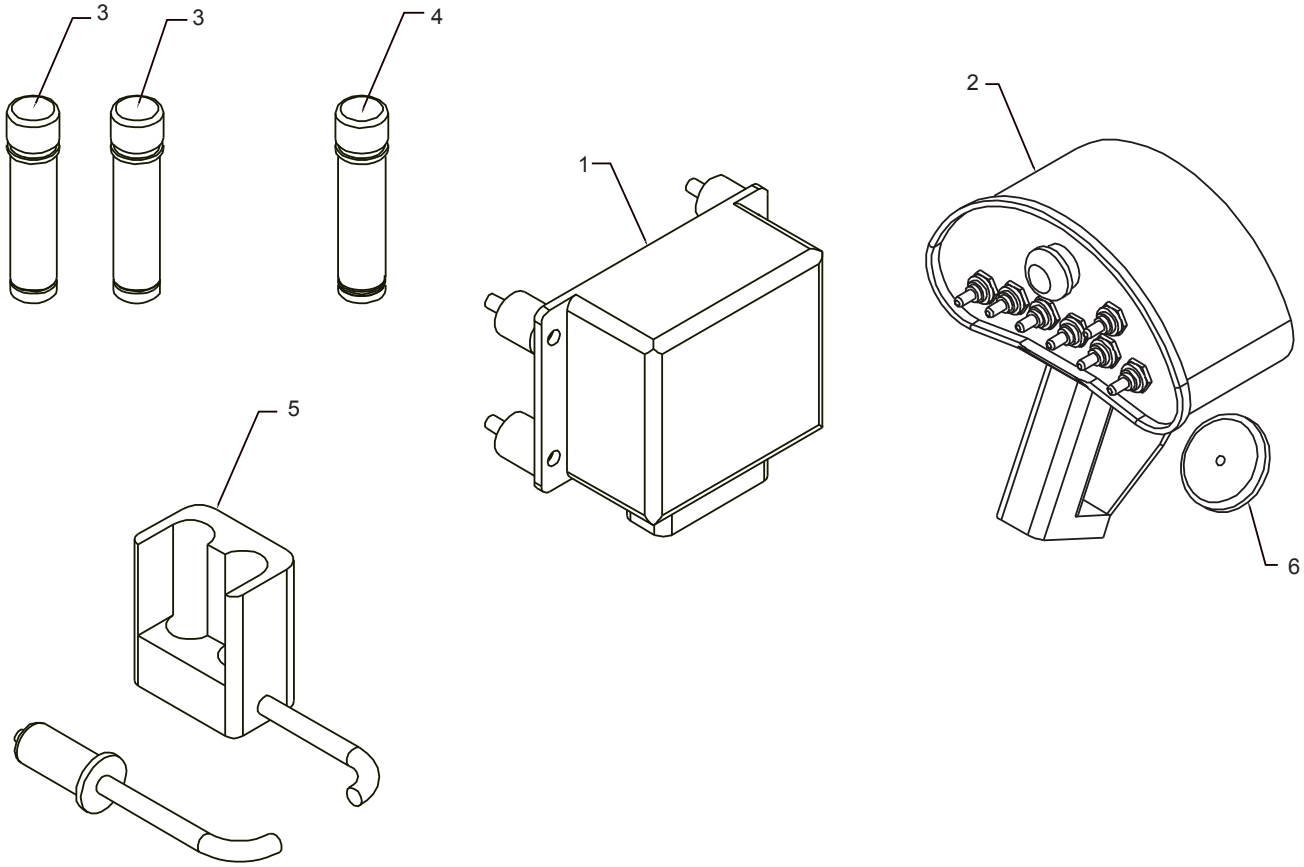

SECTION 4. GENERAL REFERENCE

INSPECTION CHECKLIST	3
WIRE ROPE INSPECTION	7
HOOK INSPECTION	7
HOLDING VALVE INSPECTION	8
ANTI-TWO BLOCKING DEVICE INSPECTION	8
TORQUE DATA CHART - DOMESTIC	9
TORQUE DATA CHART - METRIC	10
TURNTABLE BEARING FASTENER TIGHTENING SEQUENCE	11
TURNTABLE BEARING INSPECTION FOR REPLACEMENT	12

NOTICE	
The user of this form is responsible in determining that these inspections satisfy all applicable regulatory requirements	
OWNER/COMPANY	
CONTACT PERSON	
CRANE MAKE & MODEL	
CRANE SERIAL NUMBER	
UNIT I.D. NUMBER	
LOCATION OF UNIT	

Inspection Checklist	
CRANES	
TYPE OF INSPECTION (check one)	
<input type="checkbox"/> DAILY (if deficiency found)	<input type="checkbox"/> QUARTERLY
<input type="checkbox"/> MONTHLY	<input type="checkbox"/> ANNUAL
DATE INSPECTED	
HOUR METER READING (if applicable)	
INSPECTED BY (print)	
SIGNATURE OF INSPECTOR	

1

REV: 11-22-11

TYPE OF INSPECTION

NOTES:

Daily and monthly inspections are to be performed by a “competent person”, who is capable of identifying existing and predictable hazards in the surroundings or working conditions which are unsanitary, hazardous, or dangerous to employees, and who has authorization to take prompt corrective measures to eliminate them.

Quarterly and annual inspections are to be performed by a “qualified person” who, by possession of a recognized degree, certificate, or professional standing, or who by extensive knowledge, training and experience, successfully demonstrated the ability to solve/resolve problems relating to the subject matter, the work, or the project.

One hour of normal crane operation assumes 20 complete cycles per hour. If operation exceeds 20 cycles per hour, inspection frequency should be increased accordingly.

Consult Operator / Service Manual for additional inspection items, service bulletins and other information.

Before inspecting and operating crane, crane must be set up away from power lines and leveled with stabilizers deployed according to the crane manufacturer’s directions.

DAILY (D): Before each shift of operation, those items designated with a (**D**) must be inspected.

MONTHLY (M): Monthly inspections or 100 hours of normal operation (which ever comes first) includes all daily inspections plus items designated with an (**M**). This inspection must be recorded and retained for a minimum of 3 months.

QUARTERLY (Q): Every three months or 300 hours of normal operation (which ever comes first) includes all daily and monthly inspection items plus items designated with a (**Q**). This inspection must be documented, maintained, and retained for a minimum of 12 months, by the employer that conducts the inspection.

ANNUAL (A): Each year or 1200 hours of normal operation (which ever comes first) includes all items on this form which encompasses daily, monthly and quarterly inspections plus those items designated by (**A**). This inspection must be documented, maintained, and retained for a minimum of 12 months, by the employer that conducts the inspection.

FREQUENCY	ITEM	KEY	INSPECTION DESCRIPTION	✓ =SATISFACTORY R =RECOMMENDATION (Should be considered for corrective action) NA = Not Applicable X = Deficient (Note: If a deficiency is found, an immediate determination must be made as to whether the deficiency constitutes a safety hazard and must be corrected prior to operation.)	STATUS ✓, R, X, NA
D	1	Labels	All load charts, safety & warning labels, & control labels are present and legible.		
D	2	Crane	Check all safety devices for proper operation.		
D	3	Controls	Control mechanisms for proper operation of all functions, leaks & cracks.		
D	4	Station	Control and operator’s station for dirt, contamination by lubricants, & foreign materials.		
D	5	Hyd System	Hydraulic system (hoses, tubes & fittings) for leakage & proper oil level.		
D	6	Hook	Presence & proper operation of hook safety latches.		
D	7	Wire Rope	Inspect for apparent deficiencies per applicable requirements and manufacturer’s specifications.		
D	8	Pins	Proper engagement of all connecting pins & pin retaining devices.		
D	9	General covers.	Overall observation of crane for damaged or missing parts, cracked welds & presence of safety		
D	10	Operation	During operation, observe crane for abnormal performance, unusual wear (loose pins, wire rope damage, etc.). If observed, discontinue use & determine cause & severity of hazard.		
D	11	Remote Ctrl	Operate remote control devices to check for proper operation.		
D	12	Electrical	Operate all lights, alarms, etc. to check for proper operation.		
D	13	Anti Two-Block or Two-Block Damage Prevention	Operate anti-two-blocking or two-block prevention devices to check for proper operation.		

<h1 style="margin: 0;">Inspection Checklist</h1>	<h1 style="margin: 0;">CRANES</h1>	2
--	------------------------------------	----------

FREQUENCY	ITEM	KEY	✓ = SATISFACTORY R = RECOMMENDATION (Should be considered for corrective action) NA = Not Applicable	X = Deficient (Note: If a deficiency is found, an immediate determination must be made as to whether the deficiency constitutes a safety hazard and must be corrected prior to operation.)	STATUS
			INSPECTION DESCRIPTION	✓, R, X, NA	
D	14	Tires	Check tires (when in use) for proper inflation and condition.		
D	15	Ground or similar.	Ground conditions around the equipment for proper support, including ground settling under and conditions around and around stabilizers and supporting foundations, ground water accumulation,		
D	16	Level Position	The equipment for level position within tolerances specified by the equipment manufacturer's recommendations, both before each shift and after each move and setup.		
D	17	Operator Cab Windows	Significant cracks, breaks, or other deficiencies that would hamper the operator's view.		
D	18	Rails, rail stops, clamps, supporting surfaces.	Rails, rail stops, rail clamps and supporting surfaces when the equipment has rail traveling.		
D	19	Safety Devices	Safety devices and operational aids for proper operation.		
D	20	Electrical	Electrical apparatus for malfunctioning, signs of apparent excessive deterioration, dirt or moisture accumulation.		
D	21	Other			
D	22	Other			
M	23	Daily	All daily inspection items.		
M	24	Cylinders	Visual inspection of cylinders for leakage at rod, fittings & welds. Damage to rod & case.		
M	25	Valves	Holding valves for proper operation.		
M	26	Valves	Control valve for leaks at fittings & between sections.		
M	27	Valves	Control valve linkages for wear, smoothness of operation & tightness of fasteners. Relief valve for proper pressure settings.		
M	28	General	Bent, broken or significantly rusted/corroded parts.		
M	29	Electrical	Electrical apparatus for malfunctioning, signs of apparent excess deterioration, dirt or moisture accumulation. Electrical systems for presence of dirt, moisture and frayed wires.		
M	30	Structure	All structural members for damage.		
M	31	Welds	All welds for breaks & cracks.		
M	32	Pins	All pins for proper installation & condition.		
M	33	Hardware	All bolts, fasteners & retaining rings for tightness, wear & corrosion		
M	34	Wear Pads	Condition of wear pads.		
M	35	Pump & Motor mounting bolts.	Hydraulic pumps & motors for leakage at fittings, seals & between sections. Check tightness of mounting bolts.		
M	36	PTO	Transmission/PTO for leakage, abnormal vibration & noise, alignment & mounting bolt torque.		
M	37	Hyd Fluid	Quality of hydraulic fluid and for presence of water.		
M	38	Hyd Lines	Hoses & tubes for leakage, abrasion damage, blistering, cracking, deterioration, fitting leakage & secured properly.		
M	39	Hook	Load hook for abnormal throat distance, twist, wear & cracks.		
M	40	Wire Rope	Condition of load line.		
M	41	Manual	Presence of operator's manuals with unit.		
M	42		Other		
M	43		Other		
Q	44	Daily	All daily inspection items.		
Q	45	Monthly	All monthly inspection items.		
Q	46	Rotation Sys	Rotation bearing for proper torque of all mounting bolts.		
Q	47	Hardware	Base mounting bolts for proper torque.		
Q	48	Structure	All structural members for deformation, cracks & corrosion.		
	49		● Base		
	50		● Stabilizer beams & legs		
	51		● Mast		
	52		● Inner boom		
	53		● Outer boom		
	54		● Extension(s)		
	55		● Jib boom		
	56		● Jib extension(s)		
	57		● Other		
Q	58	Hardware	Pins, bearings, shafts, gears, rollers, & locking devices for wear, cracks, corrosion & distortion.		

Inspection Checklist			CRANES	3	
FREQUENCY	ITEM	KEY	✓ = SATISFACTORY R = RECOMMENDATION (Should be considered for corrective action) NA = Not Applicable	X = Deficient (Note: If a deficiency is found, an immediate determination must be made as to whether the deficiency constitutes a safety hazard and must be corrected prior to operation.)	STATUS ✓, R, X, NA
			INSPECTION DESCRIPTION		
	59		● Rotation bearing(s)		
	60		● Inner boom pivot pin(s) & retainer(s)		
	61		● Outer boom pivot pin(s) & retainer(s)		
	62		● Inner boom cylinder pin(s) & retainer(s)		
	63		● Outer boom cylinder pin(s) & retainer(s)		
	64		● Extension cylinder pin(s) & retainer(s)		
	65		● Jib boom pin(s) & retainer(s)		
	66		● Jib cylinder pin(s) & retainer(s)		
	67		● Jib extension cylinder pin(s) & retainer(s)		
	68		● Boom tip attachments		
	69		● Other		
Q	70	Hyd Lines	Hoses, fittings & tubing for proper routing, leakage, blistering, deformation & excessive abrasion.		
	71		● Pressure line(s) from pump to control valve		
	72		● Return line(s) from control valve to reservoir		
	73		● Suction line(s) from reservoir to pump		
	74		● Pressure line(s) from control valve to each function		
	75		● Load holding valve pipe(s) and hose(s)		
	76		● Other		
Q	77	Pumps & Motors	Pumps & motors for loose bolts/fasteners, leaks, noise, vibration, loss of performance, heating & excess pressure.		
	78		● Winch motor(s)		
	79		● Rotation motor(s)		
	80		● Other		
Q	81	Valves	Hydraulic valves for cracks, spool return to neutral, sticking spools, proper relief valve setting, relief valve failure.		
	82		● Main control valve		
	83		● Load holding valve(s)		
	84		● Stabilizer or auxiliary control valve(s)		
	85		● Other		
	86		● Other		
Q	87	Cylinders	Hydraulic cylinders for drifting, rod seal leakage & leakage at welds. Rods for nicks, scores & dent s. Case for damage. Case & rod ends for damage & abnormal wear .		
	88		● Stabilizer cylinder(s)		
	89		● Inner boom cylinder(s)		
	90		● Outer boom cylinder(s)		
	91		● Extension cylinder(s)		
	92		● Rotation cylinder(s)		
	93		● Jib lift cylinder(s)		
	94		● Jib extension cylinder(s)		
	95		● Other		
Q	96	Winch	Winch, sheaves & drums for damage, abnormal wear , abrasions & other irregularities.		
Q	97	Hyd Filters	Hydraulic filters for replacement per maintenance schedule.		
A	98	Daily	All daily inspection items.		
A	99	Monthly	All monthly inspection items.		
A	100	Quarterly	All quarterly inspection items.		
A	101	Hyd Sys	Hydraulic fluid change per maintenance schedule.		
A	102	Controls	Control valve calibration for correct pressures & relief valve settings		
A	103	Valves	Safety valve calibration for correct pressures & relief valve settings.		
A	104	Valves	Valves for failure to maintain correct settings.		
A	105	Rotation Sys	Rotation drive system for proper backlash clearance & abnormal wear , deformation & cracks.		
A	106	Lubrication	Gear oil change in rotation drive system per maintenance schedule.		
A	107	Hardware	Check tightness of all fasteners and bolts.		
A	108	Wear Pads	Wear pads for excessive wear .		
A	109	Loadline	Loadline for proper attachment to drum.		

WIRE ROPE INSPECTION

Wire rope with any of the deficiencies shown below shall be removed and replaced immediately .

- A. Corrosion can be cause for replacement. Any development of corrosion must be noted and monitored closely.
- B. When there are either 3 broken wires in one strand or a total of six broken wires in all strands in any one rope lay.

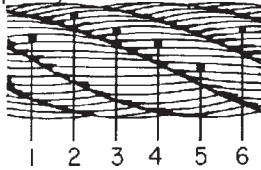

- C. When flat spots on the outer wires appear and those outside wires are less than 2/3 the thickness of the unworn outer wire.

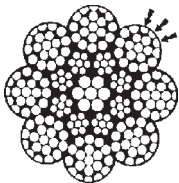

- D. When there is a decrease of diameter indicating a core failure.

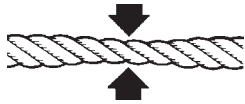

- E. When kinking, crushing, birdcaging or other distortion occurs.

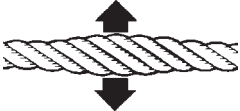

- F. When there is noticeable heat damage (discoloration) of the rope by any means.



- G. When the diameter is reduced from nominal size by 1/32" or more.



- H. If a broken wire protrudes or loops out from the core of the rope.



HOOK INSPECTION

Hooks having any of the listed deficiencies shall be removed from service unless a qualified person approves their continued use and initiates corrective action. Hooks approved for continued use shall be subjected to periodic inspection.

A. DISTORTION

Bending / Twisting

A bend or twist exceeding 10° from the plane of the unbent hook.

Increased Throat Opening

HOOK WITHOUT LATCH: An increase in throat opening exceeding 15% (Or as recommended by the manufacturer)

HOOK WITH LATCH: An increase of the dimension between a fully-opened latch and the tip section of the hook exceeding 8% (Or as recommended by the manufacturer)

B. WEAR

If wear exceeds 10% of the original sectional dimension. (Or as recommended by the manufacturer)

C. CRACKS, NICKS, GOUGES

Repair of cracks, nicks, and gouges shall be carried out by a designated person by grinding longitudinally , following the contour of the hook, provided that no dimension is reduced more than 10% of its original value. (Or as recommended by the manufacturer) (A qualified person may authorize continued use if the reduced area is not critical.)

D. LATCH

Engagement, Damage & Malfunction

If a latch becomes inoperative because of wear or deformation, and is required for the service involved, it shall be replaced or repaired before the hook is put back into service. If the latch fails to fully close the throat opening, the hook shall be removed from service or "moused" until repairs are made.

E. HOOK ATTACHMENTS & SECURING MEANS

If any indication of distortion, wear, cracks, nicks or gouges are present, unless a qualified person authorizes their use. (Or as recommended by the manufacturer)

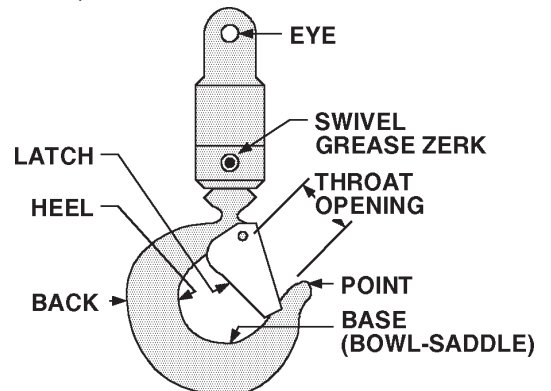

HOLDING VALVE INSPECTION

The cylinders are equipped with holding valves that prevent sudden movement of the cylinder rods in the event of a hydraulic hose or other hydraulic component failure. The valve is checked in the following manner:

1. With a full rated load, extend the cylinder in question and kill the engine.
2. Operate the control valve to retract the cylinder. If the cylinder “creeps”, replace the holding valve. If the cylinder does not “creep”, the valve is serviceable.

TWO BLOCK PREVENTION DEVICE INSPECTION

(See Vol. 1, Operation, Maintenance and Repair for a complete description)

The two block prevention system halts the “winch-up” and “extension-out” crane functions before the block contacts the sheave. The two block prevention system should be checked daily as follows:



1. Examine flexible rod and weight to insure free unrestricted mechanical operation
2. Examine cord for damage, cuts or breaks. Grasp cord and pull to check operation of cord reel. The cord should retract on reel when released.
3. Start vehicle, engage PTO and slowly winch loadline up until anti-two block weight comes in contact with the hook end of the loadline cable. At the moment the weight is fully supported by the hook end, the winch up function should become non-functioning, because the two-block damage prevention switch will stop further movement.

If operation other than as described occurs, stop immediately and investigate. Failure to do so will risk damage to the cable or the crane.

Then, extend the winch cable to relieve the two-block condition, and actuate the boom extend function slowly . Again, once the weight is fully supported by the hook end, the boom extend function should become non-functioning, because the two-block damage prevention switch will stop further movement. If operation other than described occurs, stop immediately , reverse the function, and check the system.

If the anti two block function appears to be functioning normally, winch the cable down until the sensing weight swings free.

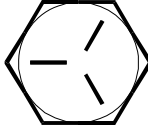
COARSE THREAD BOLTS

SIZE (DIA-TPI)	BOLT DIA (INCHES)	TIGHTENING TORQUE			
		 SAE J429 GRADE 5		 SAE J429 GRADE 8	
		PLAIN (FT-LBS)	PLATED (FT-LBS)	PLAIN (FT-LBS)	PLATED (FT-LBS)
5/16-18	0.3125	17	13	25	18
3/8-16	0.3750	31	23	44	33
7/16-14	0.4375	49	37	70	52
1/2-13	0.5000	75	57	105	80
9/16-12	0.5625	110	82	155	115
5/8-11	0.6250	150	115	220	160
3/4-10	0.7500	265	200	375	280
7/8-9	0.8750	395	295	605	455
1-8	1.0000	590	445	910	680
1 1/8-7	1.1250	795	595	1290	965
1 1/4-7	1.2500	1120	840	1815	1360
1 3/8-6	1.3750	1470	1100	2380	1780
1 1/2-6	1.5000	1950	1460	3160	2370

When using the torque data in the charts above, the following rules should be observed.



1. Bolt manufacturer’s particular specifications should be consulted when provided.
2. Flat washers of equal strength must be used.
3. All torque measurements are given in foot-pounds. To convert to inch-pounds, multiply by 12.
4. Torque values specified are for bolts with residual oils or no special lubricants applied. If special lubricants of high stress ability, such as Never-Seez compound graphite and oil, molybdenum disulphite, colloidal copper or white lead are applied, multiply the torque values in the charts by the factor .90. The use of Loctite does not affect the torque values listed above.
5. Torque values for socket-head cap screws are the same as for Grade 8 capscrews.

WARNING

Anytime a gear-bearing bolt is removed, it must be replaced with a new bolt of the identical grade and size. Once a bolt has been torqued to 75% of its proof load and then removed, the torque coefficient may no longer be the same as when the bolt was new thus giving indeterminate clamp loads after torquing. Failure to replace gear-bearing bolts may result in bolt failure due to metal fatigue causing serious injury or DEATH.

TORQUE DATA CHART - DOMESTIC

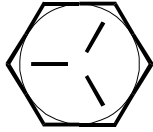
FINE THREAD BOLTS

SIZE (DIA-TPI)	BOLT DIA (INCHES)	TIGHTENING TORQUE			
		 SAE J429 GRADE 5		 SAE J429 GRADE 8	
		PLAIN (FT-LBS)	PLATED (FT-LBS)	PLAIN (FT-LBS)	PLATED (FT-LBS)
5/16-24	0.3125	19	14	27	20
3/8-24	0.3750	35	26	49	35
7/16-20	0.4375	55	41	78	58
1/2-20	0.5000	90	64	120	90
9/16-18	0.5625	120	90	170	130
5/8-18	0.6250	170	130	240	180
3/4-16	0.7500	300	225	420	315
7/8-11	0.8750	445	325	670	500
1-12	1.0000	645	485	995	745
1 1/8-12	1.1250	890	670	1445	1085
1 1/4-12	1.2500	1240	930	2010	1510
1 3/8-12	1.3750	1675	1255	2710	2035
1 1/2-12	1.5000	2195	1645	3560	2670

COARSE THREAD BOLTS

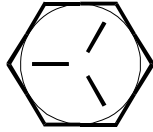
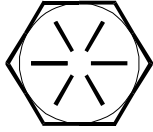
SIZE (DIA-TPI)	BOLT DIA (INCHES)	TIGHTENING TORQUE			
		 SAE J429 GRADE 5		 SAE J429 GRADE 8	
		PLAIN (FT-LBS)	PLATED (FT-LBS)	PLAIN (FT-LBS)	PLATED (FT-LBS)
5/16-18	0.3125	17	13	25	18
3/8-16	0.3750	31	23	44	33
7/16-14	0.4375	49	37	70	52
1/2-13	0.5000	75	57	105	80
9/16-12	0.5625	110	82	155	115
5/8-11	0.6250	150	115	220	160
3/4-10	0.7500	265	200	375	280
7/8-9	0.8750	395	295	605	455
1-8	1.0000	590	445	910	680
1 1/8-7	1.1250	795	595	1290	965
1 1/4-7	1.2500	1120	840	1815	1360
1 3/8-6	1.3750	1470	1100	2380	1780
1 1/2-6	1.5000	1950	1460	3160	2370

When using the torque data in the charts above, the following rules should be observed.



1. Bolt manufacturer's particular specifications should be consulted when provided.
2. Flat washers of equal strength must be used.
3. All torque measurements are given in foot-pounds. To convert to inch-pounds, multiply by 12.
4. Torque values specified are for bolts with residual oils or no special lubricants applied.
If special lubricants of high stress ability, such as Never-Seez compound graphite and oil, molybdenum disulphite, colloidal copper or white lead are applied, multiply the torque values in the charts by the factor .90. The use of Loctite does not affect the torque values listed above.
5. Torque values for socket-head capscrews are the same as for Grade 8 cap screws.

WARNING

Anytime a gear-bearing bolt is removed, it must be replaced with a new bolt of the identical grade and size. Once a bolt has been torqued to 75% of its proof load and then removed, the torque coefficient may no longer be the same as when the bolt was new thus giving indeterminate clamp loads after torquing. Failure to replace gear-bearing bolts may result in bolt failure due to metal fatigue causing serious injury or DEATH.

TORQUE DATA CHART - METRIC

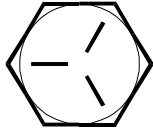
FINE THREAD BOLTS

SIZE (DIA-TPI)	BOLT DIA (INCHES)	TIGHTENING TORQUE			
		 SAE J429 GRADE 5		 SAE J429 GRADE 8	
		PLAIN (KG-M)	PLATED (KG-M)	PLAIN (KG-M)	PLATED (KG-M)
5/16-24	0.3125	3	2	4	3
3/8-24	0.3750	5	4	7	5
7/16-20	0.4375	8	6	11	8
1/2-20	0.5000	12	9	17	12
9/16-18	0.5625	17	12	24	18
5/8-18	0.6250	24	18	33	25
3/4-16	0.7500	41	31	58	44
7/8-11	0.8750	62	45	93	69
1-12	1.0000	89	67	138	103
1 1/8-12	1.1250	123	93	200	150
1 1/4-12	1.2500	171	129	278	209
1 3/8-12	1.3750	232	174	375	281
1 1/2-12	1.5000	304	228	492	369

COARSE THREAD BOLTS

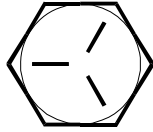
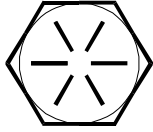
SIZE (DIA-TPI)	BOLT DIA (INCHES)	TIGHTENING TORQUE			
		 SAE J429 GRADE 5		 SAE J429 GRADE 8	
		PLAIN (KG-M)	PLATED (KG-M)	PLAIN (KG-M)	PLATED (KG-M)
5/16-18	0.3125	2	2	3	2
3/8-16	0.3750	4	3	6	5
7/16-14	0.4375	7	5	10	7
1/2-13	0.5000	10	8	15	11
9/16-12	0.5625	15	11	21	16
5/8-11	0.6250	21	16	30	22
3/4-10	0.7500	37	28	52	39
7/8-9	0.8750	55	41	84	63
1-8	1.0000	82	62	126	94
1 1/8-7	1.1250	110	82	178	133
1 1/4-7	1.2500	155	116	251	188
1 3/8-6	1.3750	203	152	329	246
1 1/2-6	1.5000	270	210	438	328

When using the torque data in the charts above, the following rules should be observed.

1. Bolt manufacturer's particular specifications should be consulted when provided.
2. Flat washers of equal strength must be used.
3. All torque measurements are given in kilogram-meters.
4. Torque values specified are for bolts with residual oils or no special lubricants applied.
If special lubricants of high stress ability, such as Never-Seez compound graphite and oil, molybdenum disulphite, colloidal copper or white lead are applied, multiply the torque values in the charts by the factor .90. The use of Loctite does not affect the torque values listed above.
5. Torque values for socket-head capscrews are the same as for Grade 8 cap screws.

WARNING

Anytime a gear-bearing bolt is removed, it must be replaced with a new bolt of the identical grade and size. Once a bolt has been torqued to 75% of its proof load and then removed, the torque coefficient may no longer be the same as when the bolt was new thus giving indeterminate clamp loads after torquing. Failure to replace gear-bearing bolts may result in bolt failure due to metal fatigue causing serious injury or DEATH.

TURNTABLE BEARING INSPECTION FOR REPLACEMENT

Before a bearing is removed from a crane for inspection, one of the following conditions should be evident:

1. Metal particles present in the bearing lubricant.
2. Increased drive power required to rotate the crane.
3. Noise emitting from the bearing during crane rotation.
4. Rough crane rotation.
5. Uneven or excessive wear between the pinion gear and turntable gear.

If none of the above conditions exists, the bearing is functioning properly and need not be replaced. But, if one or more of the above conditions exists, inspection may be required. Limits are measured in "TILT" which is dependent on the internal clearances of the bearing. TILT is the most practical determination of a bearing's internal clearance once mounted on a crane.

Periodic readings indicating a steady increase in TILT may be an indicator of bearing wear. Note that a bearing found to have no raceway cracks or other structural irregularities should be reassembled and returned to service.

TEST PROCEDURE

1. Place crane in vertical position.
2. Set a dial indicator at 0 on the pinion cover plate at back side of mast.
3. Lower crane to the horizontal position.
4. Check and record the dial indicator change. It should not exceed the tilt measurement noted in the chart below.
5. Return the crane to the vertical position. The dial indicator should return to 0.

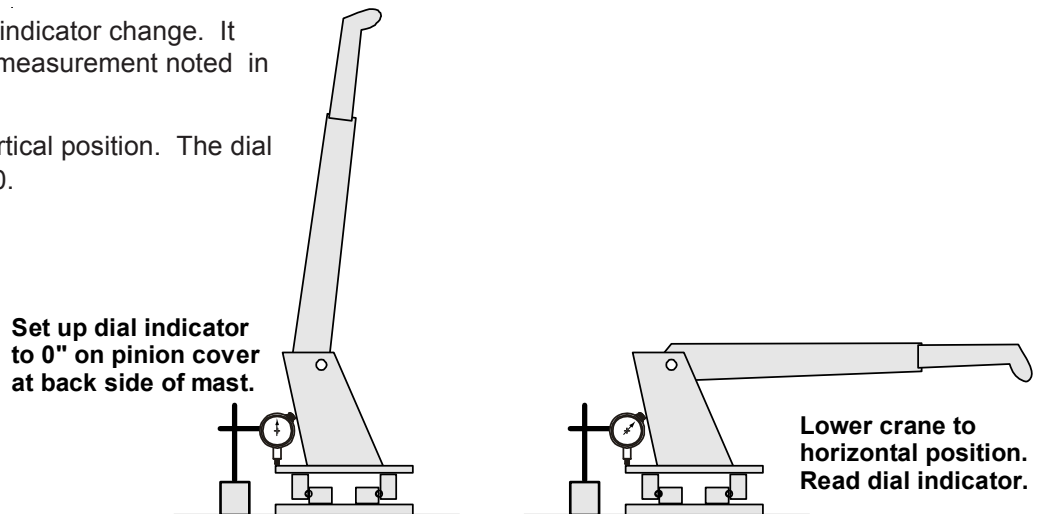

COMPARISON CHART - MODEL TO MEASURED TILT DIMENSION

<p>NOTE THE FIGURES LISTED IN THIS CHART ARE SERVICE GUIDELINES AND DO NOT, IN THEMSELVES, REQUIRE THAT THE BEARING BE INSPECTED.</p> <p>IF THERE IS REASON TO SUSPECT AN EXCESS OF BEARING WEAR AND THE MEASURED TILT DIMENSION EXCEEDS THE DIMENSION LISTED, REMOVE THE BEARING FOR INSPECTION.</p>		1007 1014 1014A 1015 2015/2020 2109 3000 3816/3820 3016/3020 421/425 4300 5016/5020 6016/6020 TH7 BODY ROT'N TH1449 BODY ROT'N TH115B CLAMP TH2551B CLAMP TH2557A CLAMP	5200 5200R 5217 5800 7020 7025 7200 7415 9000 TH10 BODY ROT'N TH14 BODY ROT'N	16000 32018 32027 32030 T30 T40	9800 12916 13031 13034 14000 15000 18000 20017 8000L H1200 H1200RR T50 TH2551B BODY ROT'N TH2557B BODY ROT'N TH2557A BODY ROT'N
	BALL DIA. (REF)	.875" (22mm)	1.00" (25mm)	1.18"-1.25" (30-32mm)	1.75" (44mm)
	TILT DIM. (A₁-A₂)	.060" (1.524mm)	.070" (1.778mm)	.075" (1.905mm)	.090" (2.286mm)

The information within this manual has been compiled and checked but errors do occur. To provide our customers with a method of communicating those errors we have provided the Manual Change Request form below. In addition to error reporting, you are encouraged to suggest changes or additions to the manual which would be of benefit to you. We cannot guarantee that these additions will be made but we do promise to consider them. When completing the form, please write or print clearly. Submit a copy of the completed form to the address listed below

MANUAL CHANGE REQUEST

DATE	PRODUCT MANUAL	MANUAL PART NO.
SUBMITTED BY		
COMPANY		
ADDRESS		
CITY, STATE, ZIP		
TELEPHONE		

ERROR FOUND

LOCATION OF ERROR (page no.): _____

DESCRIPTION OF ERROR: _____

ERROR FOUND

DESCRIPTION OF ADDITION: _____

REASON FOR ADDITION: _____

MAIL TO:
IOWA MOLD TOOLING CO., INC.
 BOX 189
 GARNER, IA 50438-0189
 ATTN: Technical Publications

This parts manual is provided to the user to assist in servicing the equipment. It is the property of Iowa Mold Tooling Co., Inc. and, as such, may not be reproduced either whole or in part, whether by chemical, electrostatic, mechanical or photographic means without the expressed written permission of an officer of Iowa Mold Tooling Co., Inc. One manual is provided with each piece of new equipment and additional manuals may be obtained at a nominal price. Your distributor may have access to this manual through the IMT web site at www.IMT.com.



IOWA MOLD TOOLING CO., INC.
BOX 189, GARNER, IA50438-0189
TEL: 641-923-3711
TECHNICAL SUPPORT FAX: 641-923-2424
www.imt.com