



Link-Belt
C R A N E S

ATC 3210

210-ton (185.0 mt) All Terrain Crane

- 44.3 ft to 200.1 ft (13.5-61m) six-section formed full power latching boom
- Seven boom extend modes provide superior capacities: EM1-EM7
- Optional 12-40-67 ft (3.65-12.2-20.42m) three-piece, bi-fold, on-board lattice attachment with 2°, 15°, 30°, and 45° manual offsets, and 2°- 45° hydraulic offsets
- Optional two 25 ft (7.62m) plus 67 ft (20.42m) provide a total attachment length of 117 ft (35.66m)
- 326.7 ft (99.6m) maximum tip height
- Modular style counterweights - 115,500 lbs (52.4 t)
- 22,510 lbs (100, 13.kn) maximum winch line pull
- 405 fpm (123.4 m/min) maximum winch line speed
- Next generation tilting operator's cab
- Automated manual transmission with 2-speed auxiliary transmission
- Anti-lock (ABS) disc brakes
- "Stow 'n Go" steel pontoons
- LED nighttime light package available



**ANSI
B30.5
TESTED**

ATC 3210

210-ton (185.0 mt) All Terrain Crane

Outstanding mobility on the road and on the job site

- Cruise control
- **Five stage interder** brake control lever
- **Three stage engine** compression brake
- Ether injection system – optional
- **Automated transmission** (no clutch pedal) — 12 speeds forward, 2 speeds reverse with two modes of operation: fully automatic and semi-automatic
- 2-Speed auxiliary transmission
- Job site travel is permissible with all 115,500 lbs (52.4 t) of counterweight for exceptional job site versatility:
 - ATC: 0.58 mph (0.93 km/hr) job site travel
- Highway speeds unmatched in the industry today: up to 62 mph (99.78 km/hr)
- **6-section full power latching boom with attachment flexibility**
- **Big, wide cab with outstanding visibility**
- **Winches deliver impressive numbers of line pull and line speed**
- **Counterweight flexibility, big engine and transmission power, along with hydro-gas suspension promise incredible mobility on the road or on the job**

12-40-67 ft (3.6-12.2-20.4 kg) three-piece bi-fold lattice attachment with 2°, 15°, 30° and 45° manual offsets and 2°-45° hydraulic offsets



Rear electrical and air connections



Boom dolly/trailer ready

Steer Coordinated



Steer Front



Steer Diagonal



Steer Rear



Large engine doors allow for easy access

Heated and powered rear viewing mirrors

Integrated air conditioning (not a roof-mounted system)

Optional daytime running lights

Self-storing fifth outrigger pontoon

Powerful and responsive hydraulics

- Seven pumps, pressure compensated hydraulic system allows simultaneous and precise function of boom hoist, winch, and swing.
- Two-speed hydraulic piston motor hoist system delivers superior hoisting. Matched size front and optional rear winches provide equal max line pulls of 22,510 lbs (100 13 Kn) and max line speeds of 405 fpm (123.4 m/min) on 15" (38.1 cm) root diameter grooved drums.
- Drum rotation indicators - standard.
- Two bi-directional hydraulic swing motors mounted to a planetary reduction unit for 360° continuous smooth swing. Spring applied hydraulic released 360° swing park brake provides infinite swing park positions as well as free swing when control is in neutral position.



The Confined Area Lifting Capacities (CALC) system provides three outrigger positions:

- full retraction • intermediate extension • full extension

Outrigger pins eliminate guesswork by automatically positioning outriggers at midpoint position.

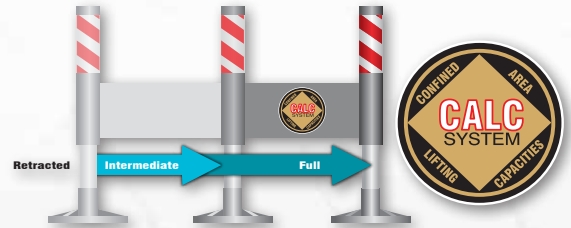

Mechanical boom angle indicator - standard

Innovative two-part paint coating technology, coupled with pre-assembly paint process, provides the finest quality coating system available today.

Standard integrated air conditioning

Pull-out CabWalk™ slides out from secured travel position underneath operator's cab

Non-slip surface strips on carrier deck

Folding viewing mirror for travel

0° to 20° tilting open cab

Optional hoist drum cable follower and optional third wrap indicators with and without function kickout

Folding guard rails

Hydraulic assist winch removal

Folding cat walks

Carrier-mounted outrigger controls located on each side of carrier, include an engine start and stop and engine throttle-up switch for fast outrigger deployment. For fine level adjusting of the carrier, throttle can be taken down to idle.



(ABS) disc brakes

Military grade aluminum wheels and radial tires

Stow 'n Go outrigger pontoons



Comfortable carrier :

- Dash-mounted comprehensive instrumentation with backlit gauges
- Roll up/down door window provides excellent ventilation
- Fully adjustable air-ride fabric seat
- Suspended pedals
- Right side carrier and backup cameras

Lower

Hydraulic reservoir

- 10 micron filtration
- 57 Gal (215.7L)



Cooling system

- Dual variable speed fans
- Radiator & charge air cooler

Air intake & cleaner

Remote Mounted Fuel Filter

Two-speed transfer case

Automatic Lubrication

Fuel tank

- 95 Gal (359.6L)

Automated manual transmission

- 12-speed forward & 2 reverse
- Integrated intruder with five brake settings

Anti-lock (ABS) disc brakes

Diesel exhaust fluid tank

- 10 Gal (37.8L)

Remote Mounted Filters

Diesel particulate filter (DPF) & selective catalyst reduction system (SCR)

Hydro-gas suspension

- No third axle lift
- Automatic ride height

2013 EPA on-highway emission-compliant engine

- 564 hp (421 kW)
- 1,850 ft-lbs (2 508 N-m)
- Engine compression brake
- Cruise control

Tier 4f off-highway emission-compliant engine

- 215 hp (160 kW)
- 700 ft-lbs (949 N-m)
- Transverse mounted

The power behind the performance

Upper

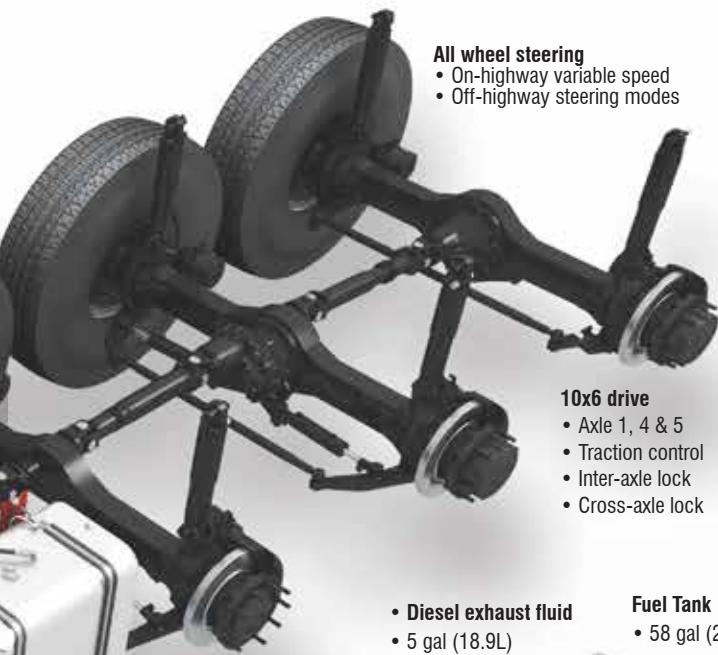

- All wheel steering**
- On-highway variable speed
 - Off-highway steering modes

- 10x6 drive**
- Axle 1, 4 & 5
 - Traction control
 - Inter-axle lock
 - Cross-axle lock

- Diesel exhaust fluid**
- 5 gal (18.9L)

- Fuel Tank**
- 58 gal (219.5L)

- Hydraulic reservoir**
- 7-micron filtration
 - Reservoir shut-off
 - 148 gal (560.2L)

- Dual drive swing motors**
- 1.5 RPMs
 - Free Swing
 - Multi-disc Brake

**Diesel Oxidation Catalyst (DOC)
Decomposition reactor tube &
Selective Catalytic Reduction (SCR)**

Hydraulic oil cooler

- Main pumps**
- 218 gpm (825.2 lpm)
 - combined pump capacity

Centralized hydraulic pressure check

Centralized upper electrical compartments

Air intake & cleaner

- Cooling system**
- Variable speed fan
 - Radiator & charge air cooler





Flood lights available



Innovative 12 ft (3.65m) fly is integral to one of the on-board fly options. Over 34 tons (30.8 mt) capacity and one-load two-line lift procedures.

Full powerboom with attachment flexibility

- Quick reeve boom head eliminates the need to remove the becket when it becomes necessary to change the reeving
- Seven extend modes for superior capacities throughout the extension range
- Available two or three-piece bi-folding lattice fly which allow the tip section to be stored, thus enhancing the lifting performance when using the base section
- Boom requires no greasing because of ingenious Teflon wear pucks impregnated in the full contact wear pads
- Two available offset fly options: manual offset with 2°, 15°, 30°, and 45°, and a hydraulic offset with 2° - 45° with no capacity deduction for luffing loads
- No deducts for stowed attachments

326.7 ft (99.6m)

302 ft (92.1m)

277.3 ft (84.5m)

250.2 ft (76.2Wm)

221.2 ft (67.4m)

210.9 ft (64.3m)

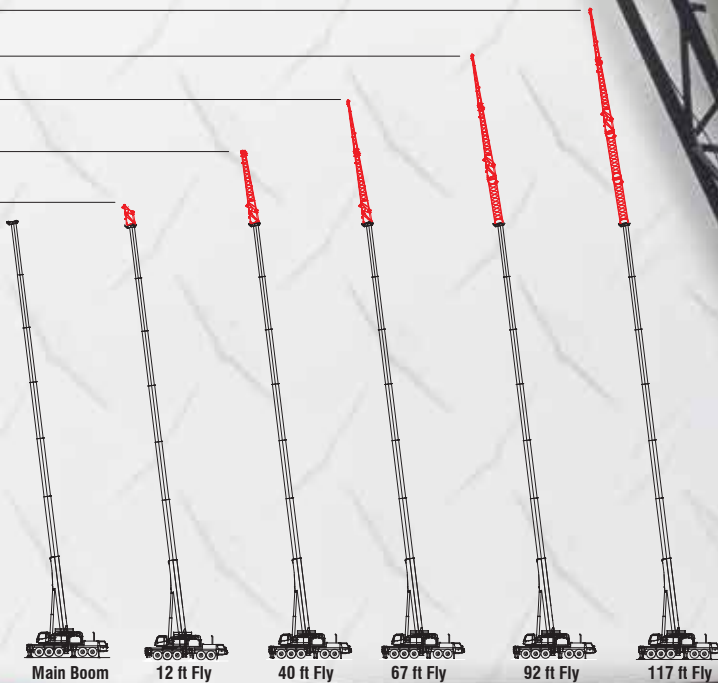



Roomier and quieter operator's cab

- Tilt cab up to 20°
- Extra large front window almost seamlessly merges into the roof window
- All gauges, switches, indicators, and controls are placed in the operators forward line of sight and backlit for nighttime operation
- Pull-out Cab Walk for easy access to and from the operator's cab
- Outtrigger and carrier engine controls
- Right side swing, main, and auxiliary winch cameras

Link-Belt PULSE



Link-Belt Pulse is the Link-Belt-designed total crane operating system. It includes the rated capacity limiter, extend mode controller, diagnostic capabilities, and continuous monitoring of multiple crane functions and conditions. To aid operators in safe and efficient operation, its high-resolution, color-intense graphic display provides excellent contrast even in direct sunlight.



Access to the engine compartments and the operator's cab is superb with strategically-located ladders and steps.



Multiple counterweight configurations give you capacities for any size job

- Standard – Total of 36,000 lbs (16 329 kg) of removable counterweights. Capacities for three different counterweight configurations.
- Optional – Up to 115,500 lbs (52 390 kg) of removable counterweights. Capacities for up to seven different counterweight configurations.
- All configurations can be raised and lowered by hydraulic cylinders from the comfort of the operator's cab for ease of installation and removal.





Link-Belt Construction Equipment Company is a leader in the design, manufacture, and sales of telescopic and lattice boom cranes with headquarters and manufacturing facilities in Lexington, Kentucky, USA. Link-Belt is committed to the manufacture and service of high quality products that satisfy customers worldwide

Towards that end, Link-Belt has pursued a strategy of growth and investment. It has moved aggressively to seize more global market share by producing a broader range of products and strengthening distribution and personnel around the globe.

Link-Belt is also home to a family of passionate professionals with a legacy of innovation and cutting-edge technology spanning over 135 years. These professionals, in a 740,000 sq. ft. (68 748 m²) manufacturing facility and with a culture of continuous innovation, have pushed Link-Belt to be the most modern crane manufacturer in North America.

Breakthrough transportability

- Unlike any all terrain the ATC-3275 can travel at a highway speed of 62 mph (100kph).
- Transports with only three overflow loads, while other all terrains in its class require up to five.
- Drive line features of anti-lock (ABS) disc brakes, transmission interarder, and true engine compression brake.
- The hydro-gas suspension delivers great articulation for jobsites and yields a smooth ride on the highway.



↑ Auxiliary winch can be removed and installed without an assist crane using only the bottom tray of the counter weight stack. A newly designed counterweight removal system allows all counterweight configurations to be raised and lowered by hydraulic cylinders from the comfort of the operator's cab.

Designed with transport in mind

Each overflow load weights under 45,000 lbs (20 412 kg).



Link-Belt
CRANES
Lexington, Kentucky | www.linkbelt.com

©Link-Belt is a registered trademark. Copyright 2013 All rights reserved. We reserve the right to change designs and specifications at any time. Litho in U.S.A 2/14 1169 #4443