

GRU A MONTAGGIO RAPIDO
 GRUE A MONTAGE RAPIDE
 GRUA DE RAPIDO MONTAJE
 GRUA DE MONTAGEM RAPIDA
 QUICK SELFERECTING CRANE
 HYDRAULISCHER SCHNELLMONTAGEKRAN

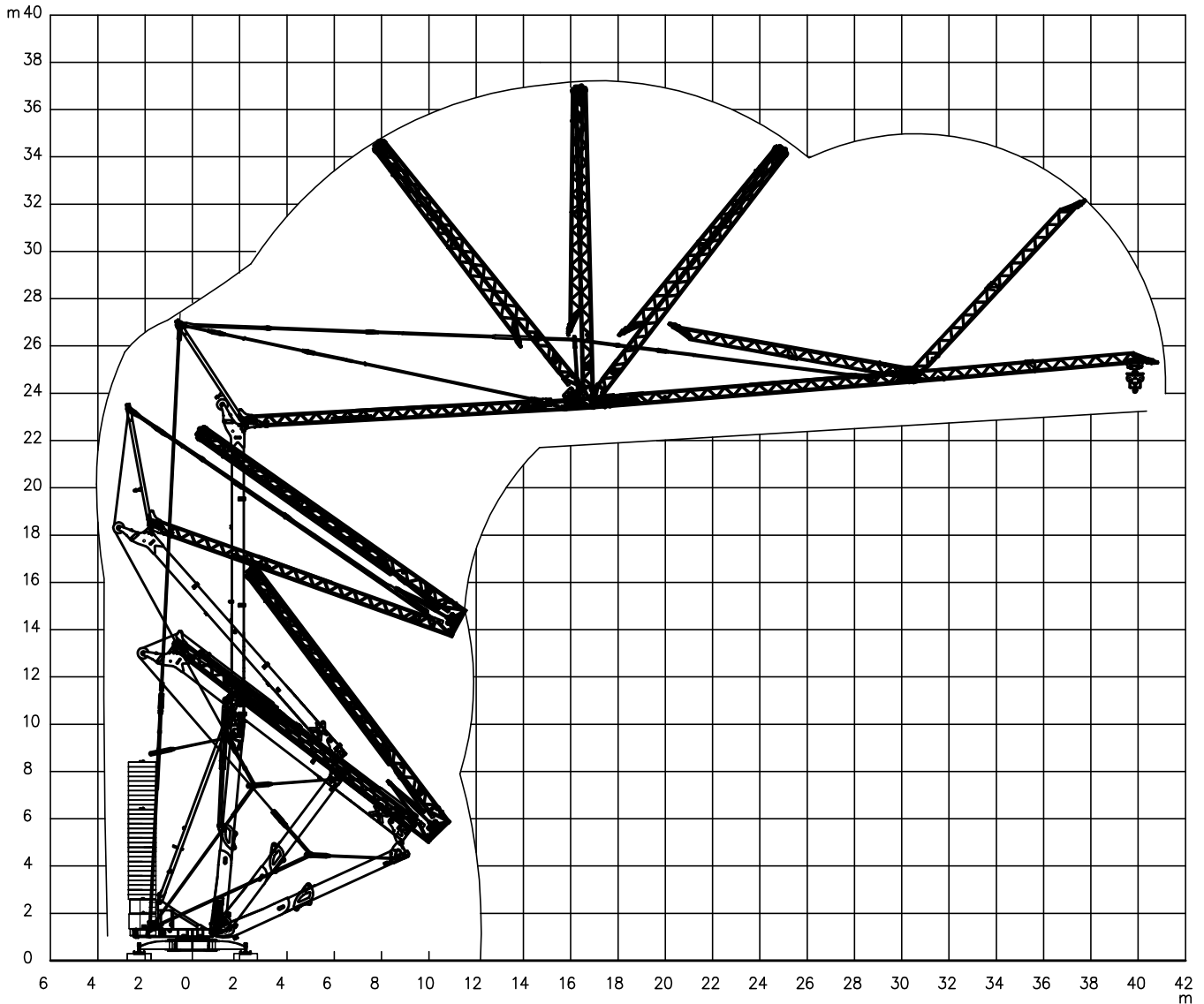

FEM 1.001 - A3

Montaggio – Montage – Erection – Montage – Montaje – Montagem



Trasporto – Transport – Transport – Transport – Transporte – Transporte

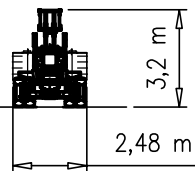
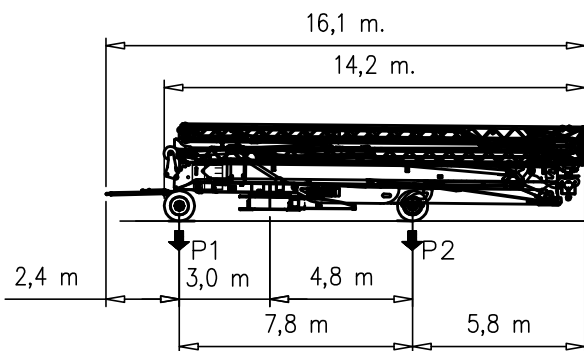

P1	kg	9000
P2	kg	16000
Ptot	kg	25000

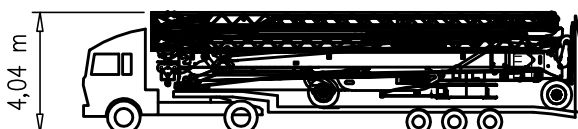

Peso con N°2 A + assali
 Weight with N°2 A + transport axles
 Poids avec N°2 A + essieux de transport
 Gewicht mit N°2 A + transportachsen
 Peso con N°2 A + ejes de transporte
 Peso com N°2 A + eixos de transporte

Curve di carico – Courbes de charges – Load diagrams – LastKurven – Curvas de cargas

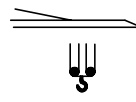
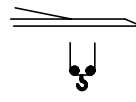
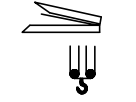
	3	20	39	m													
	1000	1000	1000	kg													
	11,1	12	14	16	18	20	22	24	26	28	30	32	34	36	38	40	m
	5000	4540	3730	3150	2720	2390	2120	1910	1730	1570	1440	1330	1230	1150	1070	1000	kg
	12,5	14	16	18	20	22	24	26	28	30	32	34	35	m			
	5000	4320	3660	3160	2780	2470	2220	2010	1840	1690	1560	1450	1400	kg			
	11,9	12	14	16	18	20	22	24	26	28	29.6	m					
5000	4910	4030	3410	2950	2590	2300	2070	1880	1710	1600	kg						
	20,1	22	24	26	28	30	32	34	36	38	40	m					
	2500	2250	2030	1840	1690	1550	1440	1340	1250	1170	1100	kg					
	22,7	24	26	28	30	32	34	35	m								
	2500	2340	2130	1950	1800	1670	1550	1500	kg								
	21,4	22	24	26	28	29.6	m										
2500	2410	2180	1980	1810	1700	kg											
	3	14	m														
	5000	5000	kg														

Reazioni – Reactions – Réactions – Eckdrücke – Reacciones – Reações

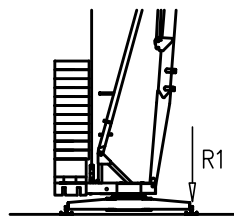





R1 ● 31 t ■ 24 t

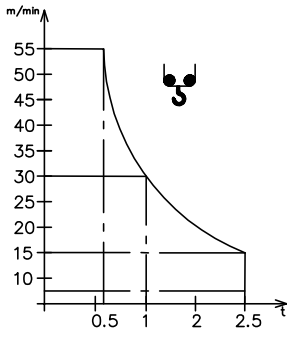
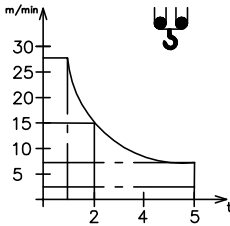
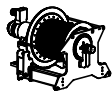

▲ 20 t ○ 29,35 t

{ N°2 A=3600Kg (1800Kgx2)
 N°2 B=2000Kg (1000Kgx2)
 N°19 C=23750Kg (1250Kgx19)

- | | | |
|--|--|---|
| ● Reazioni in servizio | ● Reactions in service | ● Réactions en service |
| ■ Reazioni fuori servizio | ■ Reactions out of service | ■ Réactions hors service |
| ▲ Peso della gru senza assali | ▲ Dead weight without transport axles | ▲ Poids de construction sans essieux |
| ○ Peso zavorra rotante | ○ Ballast weight | ○ Poids du lest |
| ● Reaktionskräfte in betrieb | ● Reacciones en servicio | ● Em serviço |
| ■ Reaktionskräfte außer betrieb | ■ Reacciones fuera de servicio | ■ Fora de serviço |
| ▲ Konstruktionsgewicht ohne transportachse | ▲ Peso de la grua sin tren de transporte | ▲ Peso de la grua sem carro de transporte |
| ○ Ballastgewicht | ○ Peso de lastre | ○ Peso de lastre rotativo |

V12.40 Sollevamento Hoisting Levage Heben Elevaciòn Elevaçao	m/min							V15.45 11 kW (15 Hp) 20 kVA 
		t	4	15	30			
	m/min							
		t	2.5	2.5	1.0			
	m/min							
		t	2	7.5	15			
	t	5.0	5.0	2.0	1.2			

Carrello Trolleying Distribution Katzfahren Distribuciòn Distribuiçao			0 → 44	m/min	4 kW
			0 → 17	m/min	4 kW

Rotazione Slewing Orientation Schwenken Orientaciòn Rotaçao			1a	0 → 0.7	giri/min tr/min rp/min	3,7 kW
			2a			
			3a			

Rete elettrica – Réseau – Mains supply – Netzstrom – Red – Alimentação	400V – 50 Hz
--	--------------

Potenza elettrica necessaria – Puissance électrique nécessaire Necessary electric power – Anschlusswert – Potencia electrica necesaria	V15.45 – 24kVA
---	----------------

Conforme alla direttiva 2000/14/CE sul livello acustico Conforme à la directive 2000/14/CE sur le niveau acoustique In compliance with the 2000/14/CE instruction on noise level Gemäss EWG-Richtlinie 2000/14/CE über Schall-Leistungspegel Conforme con la directiva 2000/14/CE sobre el nivel acustico	FEM 1.001-A3
---	--------------

 FMgru s.r.l.
 via Emilia 11-29010 Pontenure PC ITALY
 tel. 0523/510446 ric.aut. fax 0523/510365
 www.fmgru.it e-mail: info@fmgru.com



Documento commerciale non contrattuale
Per tutte le informazioni tecniche riferirsi
alle corrispondenti istruzioni

Unverbindliches Vertriebsdokument.
Für technische Informationen, siehe die
entsprechenden Anweisungen.

This commercial document is not legally
binding. For any technical information, please
refer to the corresponding instructions.

Documento commercial no contractual
Para cualquier información técnica,
ver la noticia correspondiente.

15ICA37B90A1			
Ed.	Data	Rev	Data
1	14.04.11	3	07.06.13