

Specifications

218

HYLABCS

Crawler Crane
110 Ton (99.8 metric ton)

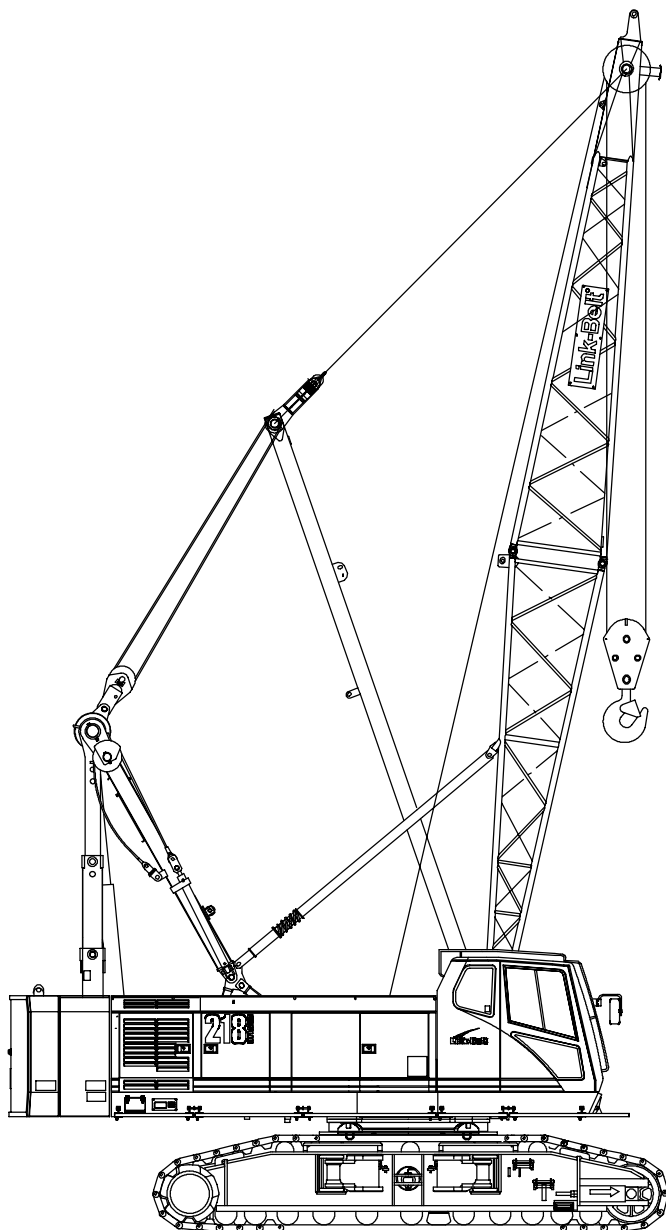

CAUTION: This material is supplied for reference use only. Operator must refer to in-cab Crane Rating Manual and Operator's Manual to determine allowable crane lifting capacities and assembly and operating procedures.

| General Dimensions | English | Metric |
|----------------------------------|----------|--------|
| Tailswing Of Counterweight "A" | 16' 2.7" | 4.9m |
| Maximum Live Mast Working Height | 34' 6" | 10.52m |
| Boom Foot Pin Diameter | 3.5" | 8.89cm |

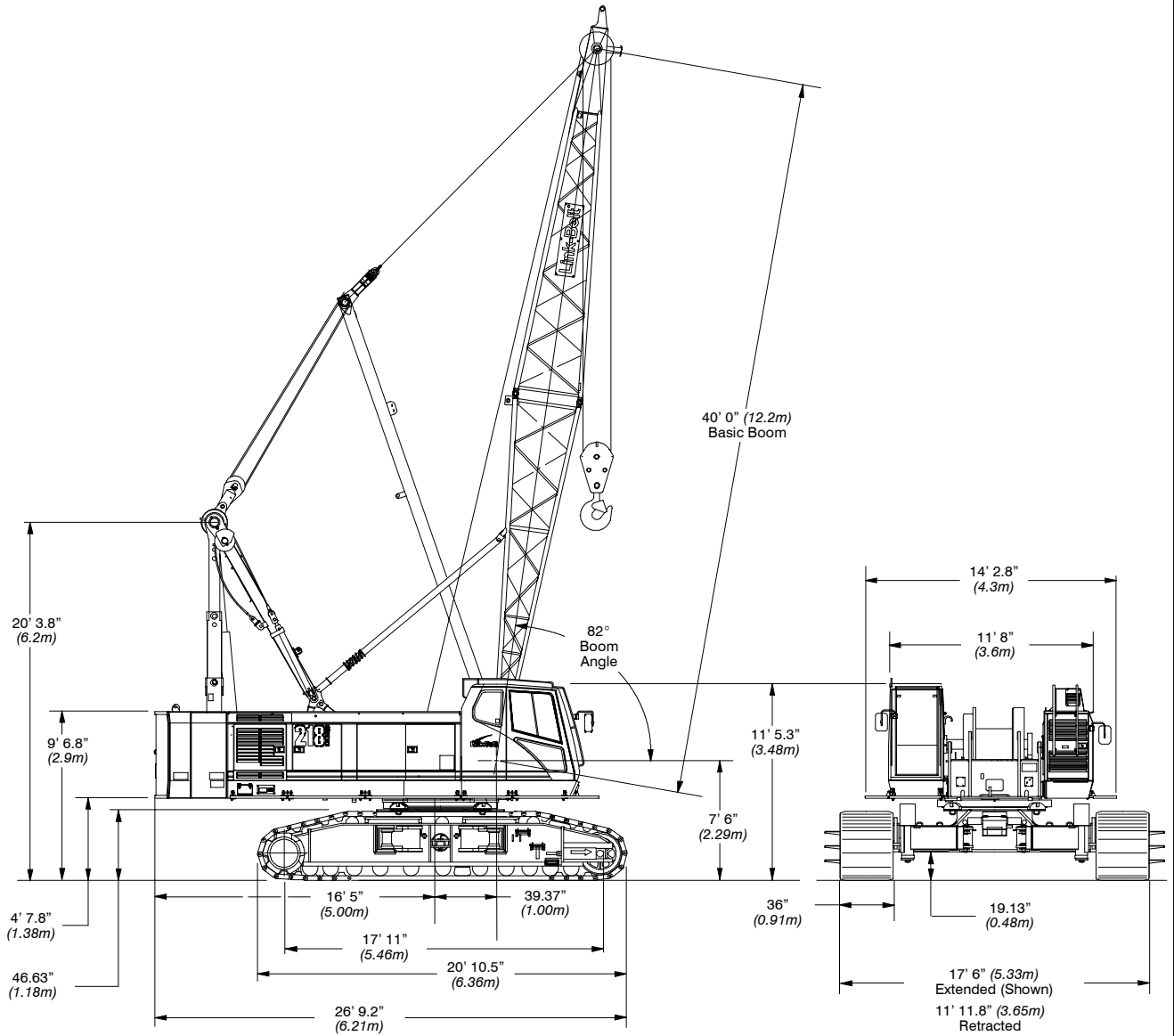

* Nominal capacity rating may vary based on specification. Tube boom capacity with 4-sheave head machinery is 110-ton (99.8mt). Tube boom capacity with optional 3-sheave head machinery and "CASAR™" rope is 100-ton (90.7mt). Angle boom capacity is 100-ton (90.7mt).

Transportation Weights

Base Crane: Rigid Boom Backstops, 77 gal (291L) Of Fuel, Catwalks (Front And Right Side), Lower Jacking System, 26' (7.9m) Live Mast, Bridle & Spreader Bar, 10-part Boom Hoist Reeving, 870' (265.18m) Of Type "DB" Front Hoist Rope, 650' (198.12m) Of Type "RB" Rear Hoist Rope.

| Item Description | Gross Weight | Transport Loads | | | | |
|---|-----------------|-----------------|---------------|---------------|---------------|---------------|
| | lb (kg) | #1 | #2 | #3 | #4 | #5 |
| Base Crane | 74,030 (33 579) | 1 | | | | |
| Add "A" Counterweight | 25,350 (11 499) | | | | 1 | |
| Add "B" Counterweight | 25,350 (11 499) | | | | | 1 |
| Add Side Frame (2 Required) | 23,561 (10 687) | | 1 | 1 | | |
| Add Hydraulic Third Drum Without Rope | 1,850 (839) | | | | | |
| Add 20' (6.1m) Tube Base Section | 1,991 (903) | 1 | | | | |
| Add 20' (6.1m) Tube Top Section | 3,690 (1 674) | | | | 1 | |
| Add 10' (3.05m) Tube Extension With Pins And Pendants | 844 (383) | 1 | | | | |
| Add 20' (6.1m) Tube Extension With Pins And Pendants | 1,353 (614) | | 1 | 1 | | |
| Add 30' (9.14m) Tube Extension With Pins and Pendants | 1,894 (859) | | 1 | 1 | | |
| Add 40' (12.19m) Tube Extension With Pins And Pendants | 2,357 (1 069) | | | | 1 | 1 |
| Add 20' (6.1m) Angle Base Section | 2,695 (1 222) | | | | | |
| Add 20' (6.1m) Angle Top Section With 4 Lifting Sheaves | 3,146 (1 427) | | | | | |
| Add 20' (6.1m) Angle Top Section With 3 Lifting Sheaves | 3,139 (1 424) | | | | | |
| Add 20' (6.1m) Angle Top Section With 2 Lifting Sheaves | 3,037 (1 378) | | | | | |
| Add 10' (3.05m) Angle Section With Pins And Pendants | 1,047 (475) | | | | | |
| Add 20' (6.1m) Angle Extension With Pins And Pendants | 1,696 (769) | | | | | |
| Add 30' (9.1m) Angle Extension With Pins And Pendants | 2,448 (1 110) | | | | | |
| Add Bridle And Spreader Bar Only (No Live Mast) | 885 (401) | | | | | |
| Add Quick Draw Assembly | 623 (283) | 1 | | | | |
| Add Tagline Winder With Rope | 1,040 (472) | | | | | |
| Add Fairleader | 500 (227) | | | | | |
| Add 30' (9.1m) Tube Jib | 1,965 (891) | | | | | 1 |
| Add 15' (4.6m) Tube Jib Extension | 290 (132) | | | | | 3 |
| Add 5' (1.5m) Auxiliary Tip Extension | 640 (290) | | | | | |
| Add Pile Driver Lead Adaptor | 198 (90) | | | | | |
| Add Holding Rope – 1" X 220' Type "DB" | 352 (160) | | | | | |
| Add Closing Rope – 1" X 165' Type "DB" | 444 (201) | | | | | |
| Add Inhaul Rope – 1" X 80' Type "M" | 185 (84) | | | | | |
| Add Hoist Rope – 1" X 700' Type "DB" | 1,295 (587) | | | | | |
| Add Hoist Rope – 1" X 700' Type "CC" | 1,421 (645) | | | | | |
| Add Jib Wire Rope – 1" X 700' Type "DB" | 1,295 (597) | | | | | |
| Add 3rd Drum Wire Rope – 0.75" X 550' Type "DB" | 572 (259) | | | | | |
| Add Auxiliary Lifting Bail | 196 (89) | | | | | |
| Add 15-ton (13.6mt) Hook Ball – Non Swivel | 750 (340) | | | | 1 | |
| Add 15-ton (13.6mt) Hook Ball – Swivel | 760 (345) | | | | | |
| Add 110-ton (100mt) 4 Sheave Hook Block | 2,946 (1 336) | | | | 1 | |
| Remove Front Hoist Rope – 1" X 870' Type "DB" | -1,610 (-730) | | | | | |
| Remove Jib Wire Rope – 1" X 650' Type "RB" | -1,300 (-590) | | | | | |
| Remove 26' (7.9m) Live Mast W/ Bridle And Spreader Bar | -2,949 (-1 338) | | | | | |
| Remove 50 gal (190L) Of Fuel | -362 (-164) | | | | | |
| Approximate Total Shipping Weight | lb | 77,488 | 26,808 | 26,808 | 35,092 | 30,542 |
| | kg | 35 148 | 12 160 | 12 160 | 15 918 | 13 854 |

Notes:

Estimated weights vary by \pm 2%. Numbers in the load columns (numbers 1–5) represent quantities.

Estimated transport loads assume the load out consist of 230' (70.1m) of tube boom and 75' (22.86m) of jib with full counterweight.

Support loads were targeted at 45,000 lb (20 412kg), 8' 6" (2.6m) wide, 48' (14.6m) long, and 13' 6" (4.1m) high using a drop deck trailer. This may vary depending on state laws, empty truck/trailer weights, and style of trailer.

Transport Drawings

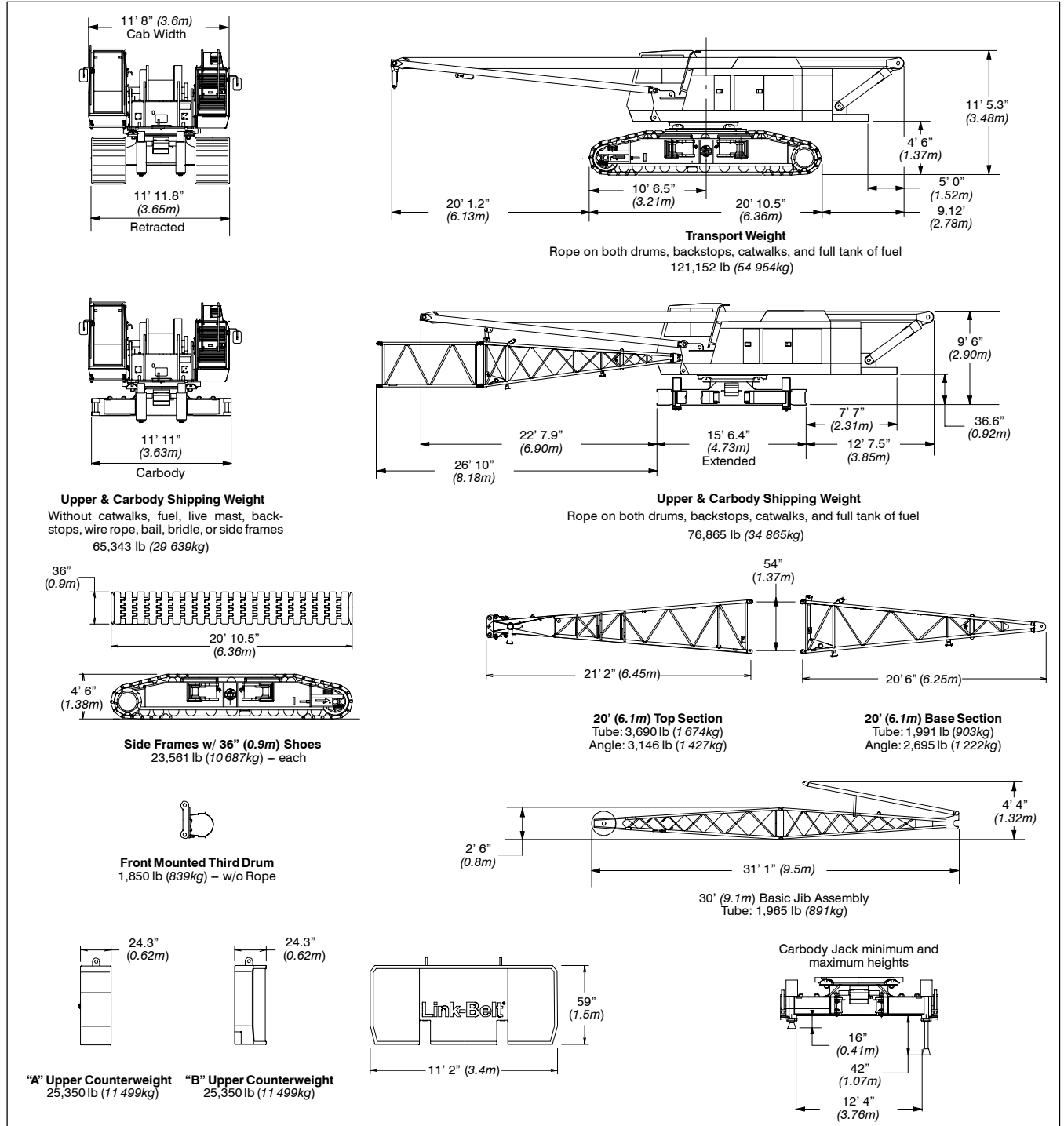

Working Weights

Based on basic crane including Mitsubishi 6D24-TLA2H diesel engine, turntable bearing, independent hydraulic powered drums, boom hoist limiting device, independent hydraulic swing and travel, counterweight, swing brake, drum rotation indicators, and crawler lower with 36" (0.91m) wide track shoes, sealed track rollers, catwalks, hydraulic boom foot pin removal, plus the following:

Lifting crane - includes 40' (12.19m) basic tubular boom, 26' (7.92m) live mast, 870' (265.18m) of 1" (25.4mm) diameter wire rope, 550' (167.6m) of 3/4" (19.1mm) diameter boom hoist rope, 110-ton (99.8mt) hook block, and basic pendants.

Ground Bearing Pressure

| | Ctwt "A" | | Ctwt "AB" | |
|--|--------------------|--------|-----------|--------|
| | lb | kg | lb | kg |
| | 153,829 | 69 776 | 179,179 | 81 274 |
| | psi | 9.58 | 11.16 | |
| | kg/cm ² | 0.67 | 0.78 | |

218 HYLAB 5 Luffing Attachment Dimensions

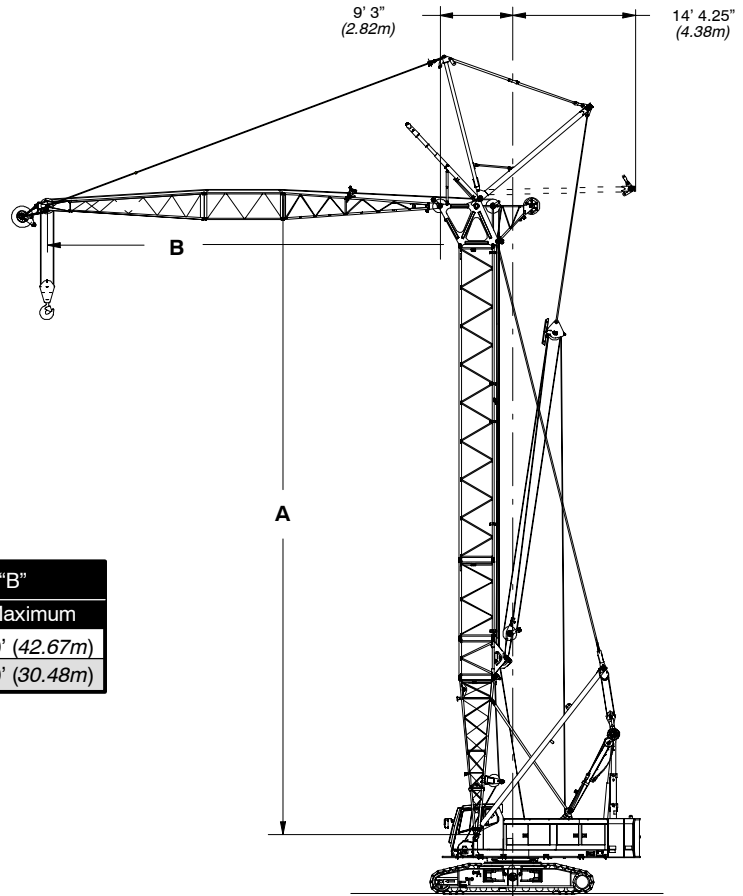

| Luffing Boom "A" | | Luffing Jib "B" | |
|------------------|---------------|-----------------|---------------|
| Minimum | Maximum | Minimum | Maximum |
| 80' (24.38m) | 140' (42.67m) | 50' (15.24m) | 140' (42.67m) |
| | 150' (45.72m) | 80' (24.38m) | 100' (30.48m) |

218 HYLAB 5 Luffing Attachment Transport

Luffing Shipping Module #1: 7,214 lb (3 272 kg)

Luffing jib base section, luffing boom top section and the front and rear fan post.

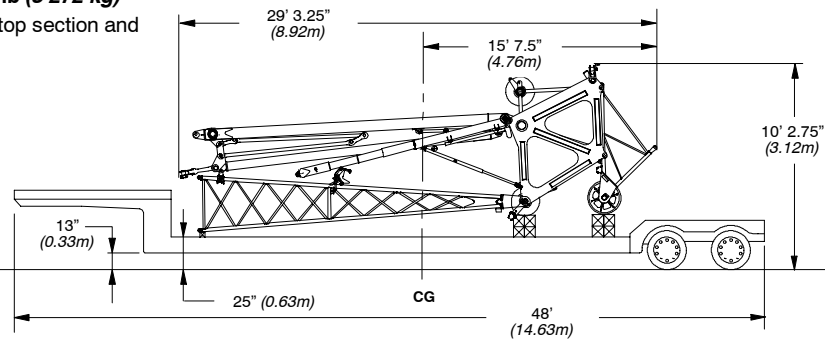

Luffing Shipping Module #2: 6,699 lb (3 039 kg)

Luffing jib peak assembly with nose wheel, 30' section (two each), 20' section (one each), 10' section (two each), 25-ton hook block and 15-ton hook ball.

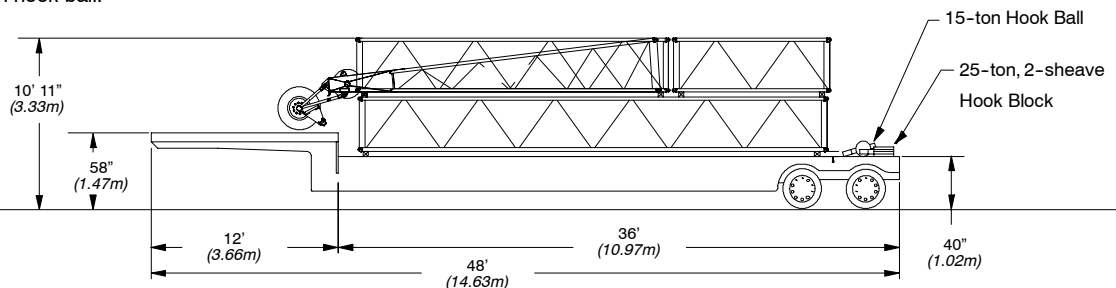

218 HYLAB 5 Luffing Attachment Nomenclature

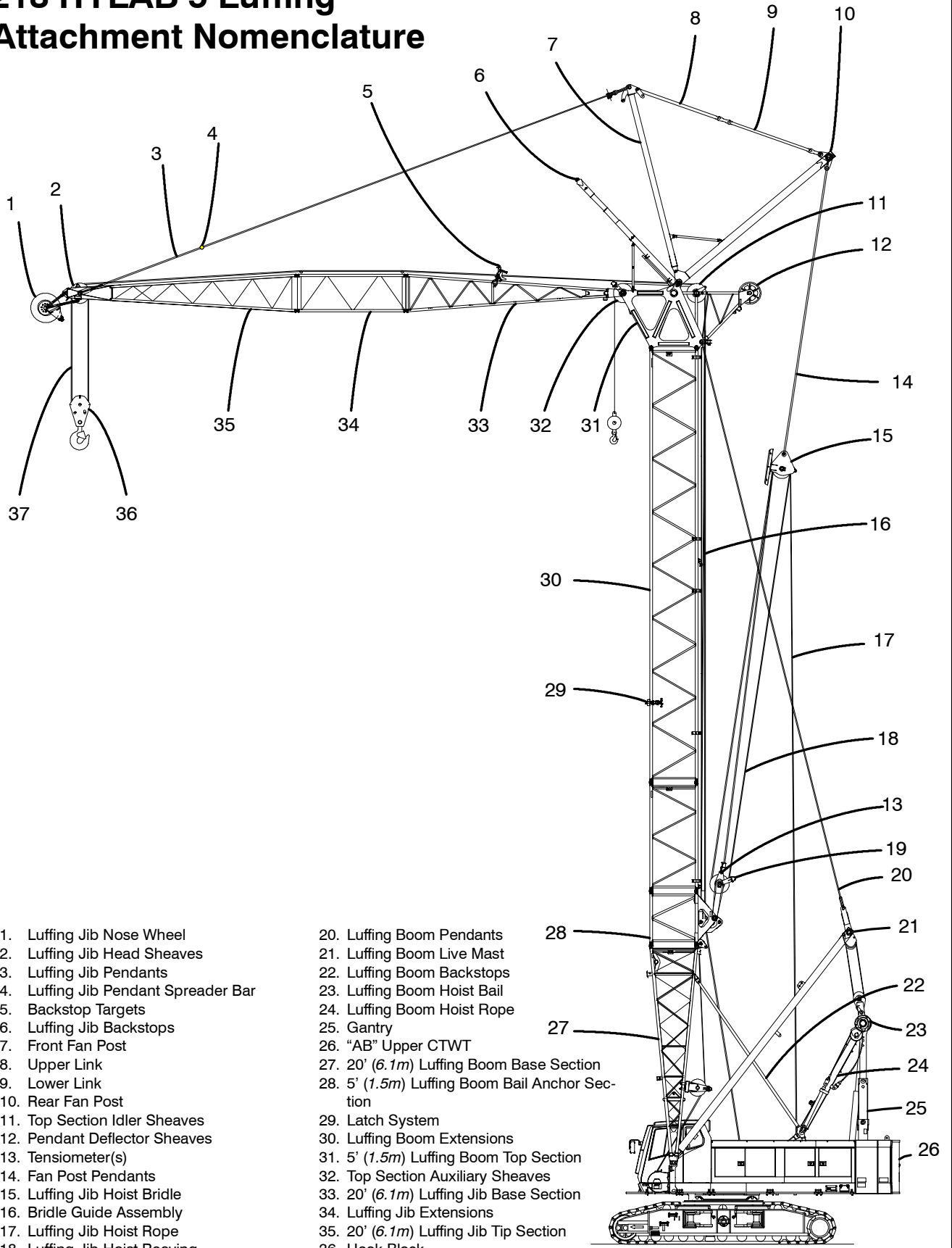

- 1. Luffing Jib Nose Wheel
- 2. Luffing Jib Head Sheaves
- 3. Luffing Jib Pendants
- 4. Luffing Jib Pendant Spreader Bar
- 5. Backstop Targets
- 6. Luffing Jib Backstops
- 7. Front Fan Post
- 8. Upper Link
- 9. Lower Link
- 10. Rear Fan Post
- 11. Top Section Idler Sheaves
- 12. Pendant Deflector Sheaves
- 13. Tensiometer(s)
- 14. Fan Post Pendants
- 15. Luffing Jib Hoist Bridle
- 16. Bridle Guide Assembly
- 17. Luffing Jib Hoist Rope
- 18. Luffing Jib Hoist Reeving
- 19. Luffing Jib Bail

- 20. Luffing Boom Pendants
- 21. Luffing Boom Live Mast
- 22. Luffing Boom Backstops
- 23. Luffing Boom Hoist Bail
- 24. Luffing Boom Hoist Rope
- 25. Gantry
- 26. "AB" Upper CTWT
- 27. 20' (6.1m) Luffing Boom Base Section
- 28. 5' (1.5m) Luffing Boom Bail Anchor Section
- 29. Latch System
- 30. Luffing Boom Extensions
- 31. 5' (1.5m) Luffing Boom Top Section
- 32. Top Section Auxiliary Sheaves
- 33. 20' (6.1m) Luffing Jib Base Section
- 34. Luffing Jib Extensions
- 35. 20' (6.1m) Luffing Jib Tip Section
- 36. Hook Block
- 37. Luffing Jib Load Hoist Rope

Attachment Options

■ 40' - 230' Tubular Boom (12.19 - 70.1m)

Basic Boom - 40' (12.19m) two-piece design that utilizes a 20' (6.10m) base section and a 20' (6.10m) open throat top section with in-line connecting pins on 60" (1.52m) wide and 50" (1.27m) deep centers.

- Boom foot on 61" (1.55m) center
- 3" (76.2mm) diameter chords
- Lugs on base section to attach carrying links
- Skywalk platform
- Deflector roller on top section
- Permanent skid pads mounted on top section to protect head machinery
- Four 21" (0.53m) root diameter steel sheaves mounted on sealed anti-friction bearings
- Tip extension and jib connecting lugs on top section
- Mechanical boom angle indicator

Optional - "Quick Draw™" handling system that mounts in the boom base to allow loading/unloading of a counterweight, a side frame or a boom section onto transport trailers.

Tube Boom Extensions - The following table provides the lengths available and the suggested quantity to obtain maximum boom in 10' (3.05m) increments. Midpoint pendant connections are required at 100' (30.5m) for boom lengths 210' (64.0m) and longer.

| Tube boom extensions | Quantity for max boom |
|----------------------|-----------------------|
| 10' (3.05m) | 1 |
| 20' (6.10m) | 2 |
| 30' (9.14m) | 2 |
| 40' (12.19m) | 2 |

- Deflector roller on top of each extension
- Appropriate length pendants
- Maximum tube boom tip height of 235' (71.63m)

■ 40'-150' Angle Boom (12.19 - 45.72m)

Basic Angle Boom - 40' (12.2m) two-piece design that utilizes a 20' (6.10m) base section and a 20' (6.10m) open throat top section with in-line connecting pins. Boom extensions are 48" (1.22m) wide and 48" (1.22m) deep at outside dimensions of angles.

- Boom foot on 61" (1.55m) center
- 4" X 4" X 0.38" (101.6 x 101.6 x 9.5mm) angle chords

- Lugs on base section to attach carrying links
- Skywalk platform
- Deflector roller on top section
- Rigid sheave guards
- Four 18" (0.46m) root diameter steel sheaves mounted on sealed anti-friction bearings
- Tip extension and jib connecting lugs on top section
- Mechanical boom angle indicator

Optional - Three sheave head machinery for clam applications or two wide mouth sheaves for dragline applications.

- Three sheave lift crane head machinery instead of standard (when used with "CASAR™ Stratoplast" rope) offers maximum capacity of 100-ton (90mt).

Angle Boom Extensions - The following table provides the lengths available and the suggested quantity to obtain maximum boom in 10' (3.05m) increments. Midpoint pendant connections are not required.

| Angle boom extensions | Quantity for max boom |
|-----------------------|-----------------------|
| 10' (3.05m) | 1 |
| 20' (6.10m) | 2 |
| 30' (9.14m) | 2 |

- Deflector roller on top of each extension
- Appropriate length pendants
- Maximum angle boom tip height of 156' (47.56m)

■ 30' - 75' Tubular Jib (9.14 - 22.86m)

Basic Tube Jib - 30' (9.14m) two-piece design that utilizes a 15' (4.57m) base section and a 15' (4.57m) top section with in-line connecting pins on 32" (0.81m) wide and 24" (0.61m) deep centers.

- 2" (50.8mm) diameter tubular chords
- One 18.5" (0.47m) root diameter steel sheave mounted on sealed anti-friction bearings.
- 15' (4.6m) jib extensions provide jib lengths at 45' (13.76m), 60' (18.3m), and 75' (22.86m) for tube boom. Angle boom is limited to 60' (18.29m).
- Jib offset angles at 5°, 15°, and 25°
- Maximum tip height of tube boom + jib is 269.5' (82.14m).
- Maximum tip height angle boom + jib is 215' (65.57m).

■ Auxiliary 5' Tip Extension (1.5m)

Designed to use in place of jib to provide clearance between working hoist lines. The extension is equipped with two nylon 18" (0.46m) root diameter sheaves mounted on sealed anti-friction bearings. Maximum capacity is 9-ton (8.16mt).

■ 50' - 140' (15.24 - 42.67m) Luffing Jib

Basic Luffing Jib - 50' (15.24m) four-piece design utilizes a 20' (6.10m) base section, 10' (3.05m) extension, 20' (6.10m) top section with in-line connecting pins and 5' (1.5m) luffing boom top section. Luffing jib extensions are 39" (0.99m) wide and 48" (1.22m) deep at the centers.

- 25-ton (22.68mt) maximum capacity
- Working lengths of 50' (15.24m) to 140' (42.67m)
- Brackets on base section to attach fan-post transport links
- Two steel 22.5" (0.57m) diameter luffing jib head sheaves
- Two polyamide 21.25" (0.54m) diameter luffing boom auxiliary head sheaves
- Pin-on nose wheel
- Eight-part luffing jib hoist.
- 1.25" (31.75mm) diameter type "N" pendants
- Anemometer with in-cab display

Luffing Jib Extensions - The following table provides the lengths available and the suggested quantity to obtain the maximum luffing jib in 10' (3.05m) increments. Midpoint pendants are not required.

| Luffing jib extensions | Quantity for max boom |
|------------------------|-----------------------|
| 10' (3.05m) | 1 |
| 20' (6.10m) | 1 |
| 30' (9.14m) | 2 |

- Deflector roller on top of each extension
- Appropriate length pendants
- Max. luffing jib tip height is 283' (86.26m).

■ Luffing Boom

- Common base and extensions as open throat boom (HP boom only)
- 5' (1.5m) luffing extension required for bail anchor.
- Working angles of 90°, 85°, 80°, 75°, 70°, and 65°
- Working lengths of 80' (24.38m) to 140' (42.67m) with luffing jib combinations up to 140' (42.67m).
- Maximum luffing boom length 150' (45.72m) with luffing jib combinations of 80' (24.38m), 90' (27.43m), and 100' (30.48m) only.
- 1.38" (34.92mm) diameter type "N" pendants; same as open throat boom.

Luffing Boom Extensions - The following table provides the lengths available and the suggested quantity to obtain the maximum luffing boom in 10' (3.05m) increments. Mid-point pendants are not required.

| Luffing boom extensions | Quantity for max boom |
|-------------------------|-----------------------|
| 10' (3.05m) | 1 |
| 20' (6.10m) | 2 |
| 30' (9.14m) | 1 |
| 40' (12.19m) | 1 |

Note: "HP" type boom must be used.

- Rear hoist drum becomes luffing jib hoist
- Optional third drum provides second working hoist line, if required.

- Designed for self-assembly
- Luffing jib hoist bridle and bail can remain reeved for crane transport
- Job site mobility with attachment
- Rolled out or rolled under erection methods
- Compact transport module.

■ Boom Hoist System

Designed to lift off maximum boom or maximum boom plus jib unassisted.

Operates up to a maximum boom angle of 82° for conventional boom and 90° for luffing boom. Boom hoist limit system limits maximum boom angle operation.

- Retractable gantry frame and

- Pin-on bail frame
- 10-part reeving with 3/4" (19mm) wire rope
- Bridle assembly
- 26' (7.92m) live mast (optional for angle attachment)
- Two 1.38" (35mm) pendants
- Tubular boom backstops (telescopic type)
- Sheaves contain sealed anti-friction bearings
- Boom speed from 10°-70° is 69 seconds with no load. Speed was determined using 100' (30.5m) of tube boom.

Revolving Upper Structure

■ Frame

All welded steel frame with precision machined surfaces for mating parts.

■ Engine

Mitsubishi 6D24-TLA2L with oil filter, oil cooler, air cleaner, fuel filter, water separator, tachometer, and electrical shutdown.

| | |
|---|-------------------------|
| Number of cylinders | 6 |
| Bore and stroke - in. (mm) | 5.12 x 5.91 (130 x 150) |
| Piston displacement - in ³ (L) | 729 (11.95) |
| Engine rpm at full load speed | 2,000 |
| Hi-idle rpm | 2,200 |
| Gross hp (kw) | 266 (198) |
| Peak torque - ft lb (joule) | 870 (1179) |
| Peak torque - rpm | 1,400 |
| Electrical system | 24 volt |
| Batteries | 2-12 volt |
| Approximate fuel consumption | gal/hr (L/hr) |
| 100% hp | 13.84 (52.40) |
| 75% hp | 10.38 (39.29) |
| 50% hp | 6.92 (26.19) |
| 25% hp | 3.46 (13.10) |

■ Hydraulic System Specifications

Hydraulic Pumps - The pump arrangement is designed to provide hydraulically powered functions allowing positive, precise control with independent or simultaneous operation of all crane functions.

- Two variable displacement pumps operating at 4,550 psi (319kg/cm²) and 83 gal/min (315L/min) powers load hoist drums, boom hoist drum, optional third drum, and travel.
- One fixed displacement gear type pump operating at 2,985 psi (210kg/cm²) and 29.6 gal/min (112L/min) powers the swing motors and side frame retract cylinders.
- One fixed displacement gear type pump operating at 2,985 psi (210kg/cm²) and

33.3 gal/min (126L/min) powers the swing motors.

- One fixed displacement gear type pump operating at 2,985 psi (210kg/cm²) and 10.8 gal/min (41L/min) powers the pilot control system, clutches, brakes, counterweight cylinders, and pump controls.
- One fixed displacement gear type pump operating at 1,420 psi (100kg/cm²) and 8.1 gal/min (31L/min) powers the oil cooler fan.

■ Pump Control ("Fine Inching") mode -

Special pump setting, selectable from operator's cab, that allows very slow movements of load hoist drums, boom hoist drum, and travel for precision work.

Hydraulic Reservoir - 53 gal (201L), equipped with sight level gauge. Diffusers built in for deaeriation.

Filtration - One 10 micron, full flow, line filter in the control circuit. All oil is filtered prior to entering the reservoir.

Counterbalance Valves - All hoist motors are equipped with counterbalance valves to provide positive load lowering and prevent accidental load drop if the hydraulic pressure is suddenly lost.

■ Load Hoist Drums

Each drum contains a pilot controlled, bi-directional, axial piston motor and a planetary gear reduction unit to provide positive control under all load conditions.

- Power up/down & free-fall operation modes
- Automatic brake mode (spring applied, hydraulically released, band type brake)
- 1" (25.4mm) grooved lagging
- Drum pawl controlled manually
- Electronic drum rotation indicators
- Mounted on anti-friction bearings
- 21.50" (0.54m) root diameter
- 40.94" (1.04m) flange diameter
- 24.63" (0.62m) width

Note: The freefall operational mode is designed to prevent load lowering even if the freefall switch is accidentally activated. The automatic brake mode meets all OSHA requirements for personnel handling.

Drum Clutches - Power hydraulic two shoe clutch design that uses a 37" (940mm) diameter x 5" (127mm) wide shoe that internally expands to provide load control. Swept area is 638 in² (4 116cm²).

■ Optional Front Mounted Third Hoist Drum

The hydraulic winch is pinned to the front of the upper frame and is used in conjunction with a fleeting sheave and 3-sheave idler assembly to run the wire rope over the boom top section.

- Free-spooling capability for pile driving applications or auxiliary hoist line for luffer applications.
- 12.75" (0.32m) root diameter
- 22.75" (0.58m) flange diameter
- 17" (0.43m) width
- Mounted on anti-friction bearings

■ Boom Hoist Drum

Contains a pilot controlled, bi-directional, axial piston motor and a planetary gear reduction unit to provide positive control under all load conditions.

- Spring applied, hydraulically released, disc type brake controlled automatically
- 3/4" (19mm) grooved lagging
- Drum pawl controlled automatically
- Mounted on anti-friction bearings
- 19.84" (0.50m) root diameter
- 33.86" (0.86m) flange diameter
- 9.82" (0.25m) width

■ Swing System

Pilot controlled bi-directional axial piston motors and planetary gear reduction unit to provide positive control under all load conditions.

- Spring applied, hydraulically released, 360° multi-plate brake
- Free swing mode when lever is in neutral position
- Four position positive house lock
- Two-speed swing
- Audio/Visual swing alarm
- Maximum swing speed is 2.4 rpm

■ Upper Counterweight

Consist of a two piece design that can be easily lowered to the ground using the gantry.

- 25,350 lb (11 499kg) "A" upper counterweight
- Optional - 25,350 lb (11 499kg) "B" upper counterweight can be added to maximize capacities

■ Operator's Cab and Controls

Fully enclosed modular steel compartment is independently mounted and insulated to protect against vibration and noise.

- All tinted/tempered safety glass
- Folding hinge entry door and sliding front glass window
- 19,000 BTU hot water heater
- 18,600 BTU air conditioner
- Door and window locks
- Circulating fan
- Sun visor
- Cloth seat
- Padded for noise and vibration reduction
- Defroster
- Windshield wipers and washer
- Dry chemical fire extinguisher
- Engine instrumentation panel (voltmeter, engine oil pressure, engine water temperature, fuel level, hydraulic oil temperature, hour meter, and service monitor system)
- Electronic drum rotation indicators for front and rear hoist drums
- Six way adjustable seat
- Hand and foot throttle
- Fully adjustable single axis controls
- Swing lever with swing brake and horn located on handle
- Bubble type level
- Ergonomic gauge layout
- Control shut off lever
- Right hand control stand is adjustable by electric motor for operator comfort
- Horn

■ Rated Capacity Limiter System

The rated capacity limiter system is a boom hoist load cell system. This system provides the operator with useful geometrical data, to include:

- Main Boom Length
- Jib Angle
- Main Boom Angle
- Jib Length
- Operating Mode
- Load Radius
- Boom Tip Height
- Audible Alarm
- Anti-Two Block Indicator
- Pre-Warning Light
- Overload Light
- Load On Hook
- Function kick-outs including over load
- Operator settable stops (Ramped Stops)
- Boom Hoist Dead End Load Cell (No Linderiders)
- Engine rpm Is Displayed On LCD1 Of SML-10 System

■ Additional Equipment - Standard

- 71.02" (1.80m) outside diameter turntable bearing
- Right and Left side removable catwalks
- 119 gal (450.4L) fuel tank (usable quantity)
- Crane lifting links

■ Additional Equipment - Optional

- Rud-o-matic® model 648 tagline winder
- Full revolving type Fairleader with barrel, sheaves, and guide rollers.

Lower Structure

■ Lower Frame

All welded box construction frame with precision-machined surfaces for turntable bearing and rotating joint.

- 10' 8" (3.25m) overall width
- 11' 11" (3.6m) overall length

■ Side Frames

All welded, precision-machined, steel frames can be hydraulically extended and retracted by a hydraulic cylinder mounted in the lower frame.

- 14' 6" (4.42m) extended gauge
- 9' (2.74m) retracted gauge
- 20' 10.5" (6.36m) overall length
- 36" (0.9m) wide track shoes
- 11 sealed (oil filled) track rollers per side frame
- Sealed (oil filled) idler and drive planetaries

- Compact travel drives
- Hydraulic adjusting tracks

Travel and Steering – Each side frame contains a pilot controlled, bi-directional, axial piston motor and a planetary gear reduction unit to provide positive control under all load conditions.

- Individual control provides smooth, precise maneuverability including full counter-rotation.
- Spring applied, hydraulically released disc type brake controlled automatically.
- Maximum travel speed is 1.44 mph (2.38km/h).
- Designed for 30% gradeability.

■ Carbody Jacks

System contains four hydraulic cylinders individually mounted on swing out beams.

- Individual controls are mounted on carbody.
- Minimum height of carbody when resting on pontoons is 16" (0.41m).
- Maximum height of carbody when resting on pontoons is 42" (1.07m).

Load Hoisting Performance

Front Or Rear Drum – 1” (25.4mm) Wire Rope

| Rope Layer | Maximum Line Pull | | No Load Line Speed | | Full Load Line Speed | | Pitch Diameter | | Layer | | Total | |
|------------|-------------------|--------|--------------------|-------|----------------------|-------|----------------|-----|-------|------|-------|-------|
| | lb | kg | ft/min | m/min | ft/min | m/min | in | mm | ft | m | ft | m |
| 1 | 57,788 | 26 212 | 194 | 59.1 | 63 | 19.2 | 22.5 | 571 | 135 | 41.1 | 135 | 41.1 |
| 2 | 53,069 | 24 072 | 212 | 64.6 | 68 | 20.7 | 24.5 | 622 | 146 | 44.5 | 282 | 86.0 |
| 3 | 49,064 | 22 255 | 229 | 69.8 | 74 | 22.6 | 26.5 | 673 | 157 | 47.9 | 439 | 133.8 |
| 4 | 45,620 | 20 693 | 246 | 75.0 | 80 | 24.4 | 28.5 | 724 | 168 | 51.2 | 608 | 185.3 |
| 5 | 42,628 | 19 336 | 264 | 80.5 | 85 | 25.9 | 30.5 | 775 | 179 | 54.6 | 787 | 239.9 |
| 6 | 40,005 | 18 146 | 281 | 85.6 | 91 | 27.7 | 32.5 | 825 | 190 | 57.9 | 977 | 297.8 |
| 7 | 37,685 | 17 094 | 298 | 90.8 | 96 | 29.3 | 34.5 | 876 | 201 | 61.3 | 1,179 | 359.4 |

Boom Hoist Drum – 3/4” (19mm) Wire Rope

| Rope Layer | Maximum Line Pull | | No Load Line Speed | | Full Load Line Speed | | Pitch Diameter | | Layer | | Total | |
|------------|-------------------|--------|--------------------|-------|----------------------|-------|----------------|-----|-------|------|-------|-------|
| | lb | kg | ft/min | m/min | ft/min | m/min | in | mm | ft | m | ft | m |
| 1 | 38,712 | 17 559 | 126 | 38.4 | 115 | 35.1 | 20.6 | 523 | 65 | 19.8 | 65 | 19.8 |
| 2 | 36,084 | 16 367 | 135 | 41.1 | 123 | 37.5 | 22.1 | 561 | 69 | 21.0 | 134 | 40.8 |
| 3 | 33,790 | 15 327 | 144 | 43.9 | 131 | 39.9 | 23.6 | 599 | 73 | 22.3 | 207 | 63.1 |
| 4 | 31,770 | 14 41 | 153 | 46.6 | 140 | 42.7 | 25.1 | 638 | 78 | 23.8 | 285 | 86.9 |
| 5 | 29,978 | 13 598 | 162 | 49.4 | 148 | 45.1 | 26.6 | 676 | 82 | 25.0 | 366 | 111.6 |
| 6 | 28,377 | 12 872 | 171 | 52.1 | 156 | 47.5 | 28.1 | 714 | 86 | 26.2 | 453 | 138.1 |
| 7 | 26,939 | 12 219 | 180 | 54.9 | 165 | 50.3 | 29.6 | 752 | 90 | 27.4 | 543 | 165.5 |

Front Mounted Third Drum – 3/4” (19mm) Wire Rope

| Rope Layer | Maximum Line Pull | | No Load Line Speed | | Full Load Line Speed | | Pitch Diameter | | Layer | | Total | |
|------------|-------------------|--------|--------------------|-------|----------------------|-------|----------------|-----|-------|------|-------|-------|
| | lb | kg | ft/min | m/min | ft/min | m/min | in | mm | ft | m | ft | m |
| 1 | 23,000 | 10 433 | 160 | 48.8 | 102 | 31.1 | 13.5 | 343 | 80 | 24.4 | 80 | 24.4 |
| 2 | 20,700 | 9 390 | 178 | 54.3 | 114 | 34.7 | 15 | 381 | 89 | 27.1 | 169 | 51.5 |
| 3 | 18,820 | 8 537 | 196 | 59.7 | 125 | 38.1 | 16.5 | 419 | 98 | 29.9 | 267 | 81.4 |
| 4 | 17,250 | 7 825 | 214 | 65.2 | 137 | 41.8 | 18 | 457 | 107 | 32.6 | 374 | 114.0 |
| 5 | 15,925 | 7 224 | 232 | 70.7 | 148 | 45.1 | 19.5 | 495 | 116 | 35.4 | 490 | 149.4 |
| 6 | 14,785 | 6 706 | 249 | 75.9 | 160 | 48.8 | 21 | 533 | 124 | 37.8 | 614 | 187.1 |

Wire Rope Applications

| Wire Rope Application | Diameter | | Length | | Type | Maximum Permissible Load | |
|------------------------|----------|------|--------|-----|------|--------------------------|--------|
| | in | mm | ft | m | | lb | kg |
| Boom Hoist | 3/4 | 19 | 550 | 168 | W | 16,800 | 7 620 |
| Front Hoist | 1 | 25.4 | 870 | 265 | DB | 29,500 | 13 381 |
| Front Hoist (Optional) | 1 | 25.4 | 700 | 213 | CC | 30,760 | 13 953 |
| Rear Hoist (Optional) | 1 | 25.4 | 650 | 198 | RB | 22,760 | 10 324 |
| Third Drum (Optional) | 3/4 | 19 | 550 | 168 | DB | 16,800 | 7 620 |

| Rope Type | Description |
|-----------|--|
| DB | 6 x 26 (6 X 19 Class) – Warrington Seal – Extra Improved Plow Steel – Preformed – Right Lay – Regular Lay – I.W.R.C. |
| RB | 19 x 19 Rotation Resistant – Extra Improved Plow Steel – Preformed – Right Lay – Regular Lay – Swaged – SF=5.1 |
| CC | 36 x 7 – Non-rotating – Extra-Extra Improved Plow Steel – Right Lay – Regular Lay – S.F.=5.1 |
| W | 6 x 26 (6 X 19 Class) – Extra Improved Plow Steel – Preformed – Right Lay – Alternate Lay – I.W.R.C. |

Link-Belt Construction Equipment Company Lexington, Kentucky www.linkbelt.com

®Link-Belt is a registered trademark. Copyright 2004. We are constantly improving our products and therefore reserve the right to change designs and specifications.