

# Wolffkran 325 SL

## TOWER CRANE

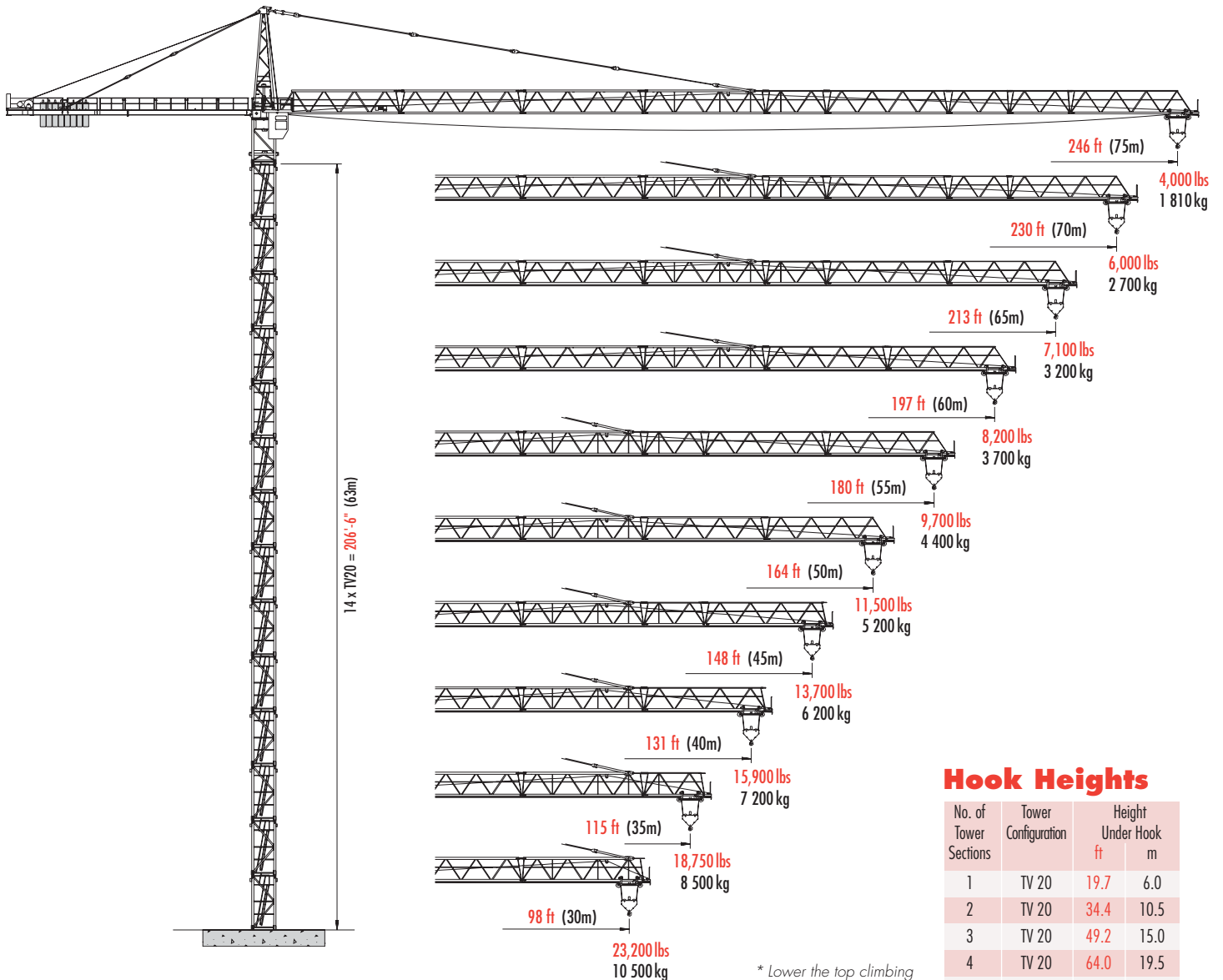

**FREESTANDING**  
(stationary)

### Hook Heights

No. of Tower Sections	Tower Configuration	Height Under Hook ft	Height Under Hook m
1	TV 20	19.7	6.0
2	TV 20	34.4	10.5
3	TV 20	49.2	15.0
4	TV 20	64.0	19.5
5	TV 20	78.7	24.0
6	TV 20	93.5	28.5
7	TV 20	108.3	33.0
8	TV 20	123.0	37.5
9	TV 20	137.8	42.0
10	TV 20	152.6	46.5
11	TV 20	167.3	51.0
12	TV 20	182.0	55.5
13	TV 20	197.0	60.0
14	TV 20* 1	211.6	64.5

\* Lower the top climbing unit to base of crane prior to operating crane at maximum hook height.

<sup>1</sup> If the VK 325 SL is erected with the 246-ft (75m) jib, the maximum stationary freestanding hook height is 197 ft (60m).

Other tower combinations are possible. Contact Morrow Equipment for additional information.



# Morrow Equipment

# Configurations

# Wolffkran 325 SL

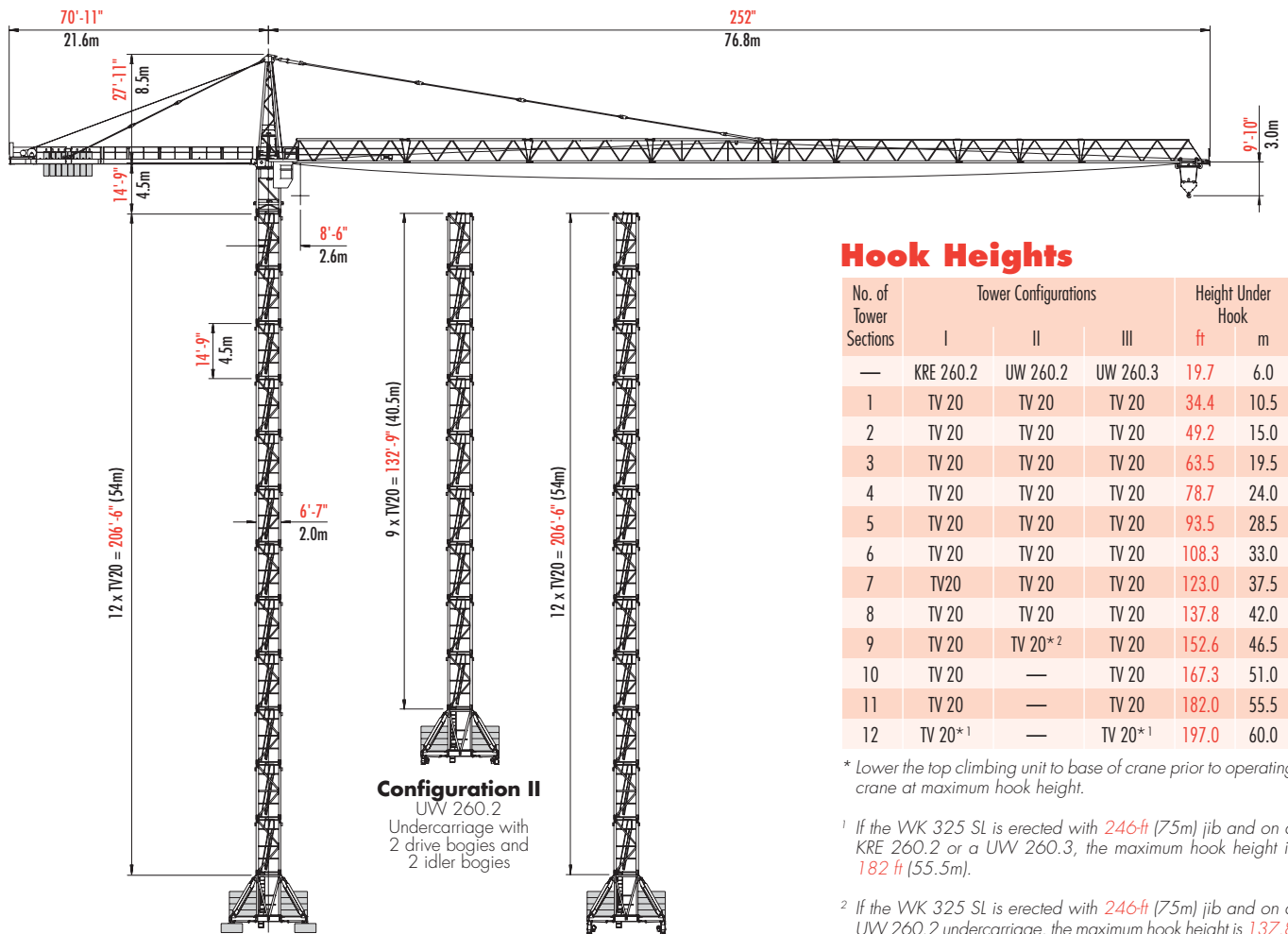

## Hook Heights

No. of Tower Sections	Tower Configurations			Height Under Hook	
	I	II	III	ft	m
—	KRE 260.2	UW 260.2	UW 260.3	19.7	6.0
1	TV 20	TV 20	TV 20	34.4	10.5
2	TV 20	TV 20	TV 20	49.2	15.0
3	TV 20	TV 20	TV 20	63.5	19.5
4	TV 20	TV 20	TV 20	78.7	24.0
5	TV 20	TV 20	TV 20	93.5	28.5
6	TV 20	TV 20	TV 20	108.3	33.0
7	TV20	TV 20	TV 20	123.0	37.5
8	TV 20	TV 20	TV 20	137.8	42.0
9	TV 20	TV 20* <sup>2</sup>	TV 20	152.6	46.5
10	TV 20	—	TV 20	167.3	51.0
11	TV 20	—	TV 20	182.0	55.5
12	TV 20* <sup>1</sup>	—	TV 20* <sup>1</sup>	197.0	60.0

\* Lower the top climbing unit to base of crane prior to operating crane at maximum hook height.

<sup>1</sup> If the WK 325 SL is erected with 246-ft (75m) jib and on a KRE 260.2 or a UWV 260.3, the maximum hook height is 182 ft (55.5m).

<sup>2</sup> If the WK 325 SL is erected with 246-ft (75m) jib and on a UWV 260.2 undercarriage, the maximum hook height is 137.8 ft (42m).

Other tower combinations are possible. Contact Morrow Equipment for additional information.

**Configuration I**  
KRE 260.2  
Cross Frame

**Configuration II**  
UW 260.2  
Undercarriage with  
2 drive bogies  
and  
2 idler bogies

**Configuration III**  
UW 260.3  
Undercarriage with  
4 drive bogies

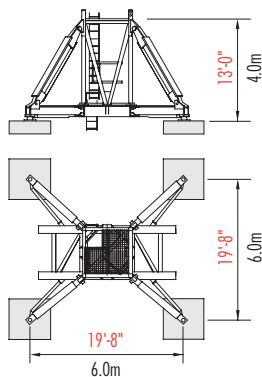

**Configuration I**  
KRE 260.2 Cross Frame

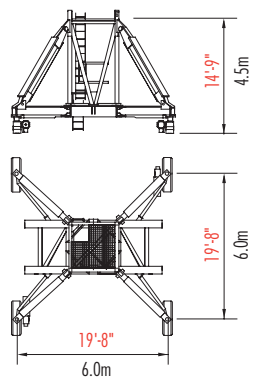

**Configuration II**  
UW 260.2 Undercarriage

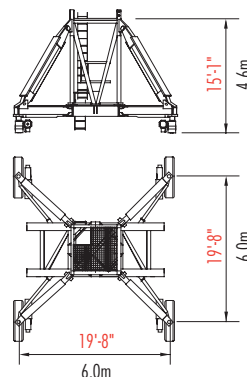

**Configuration III**  
UW 260.3 Undercarriage

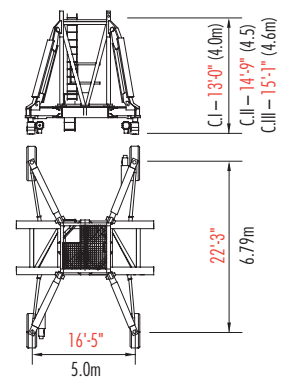

**Alternate Configuration**  
for KRE 260.2, UW 260.2 & UW 260.3 available with restrictions.  
Contact Morrow Equipment for additional information.

# Configurations

# Wolffkran 325 SL

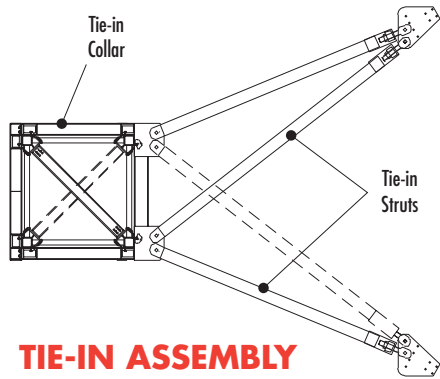

**TIE-IN ASSEMBLY**  
Plan View

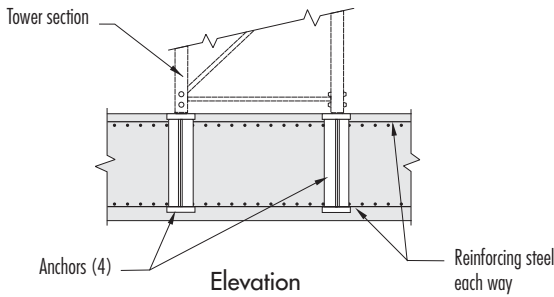

Elevation

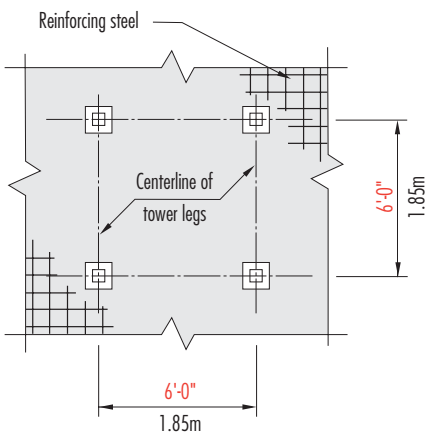

Plan View

**FOUNDATION**  
(Concrete Slab)

**NOTE!** If hook height exceeds 330 ft (100.0m), the number of tower sections above uppermost tie-in location **MUST** be reduced by 2 tower sections.

\* Lower the top climbing unit to uppermost tie-in location prior to operating crane at maximum hook height.

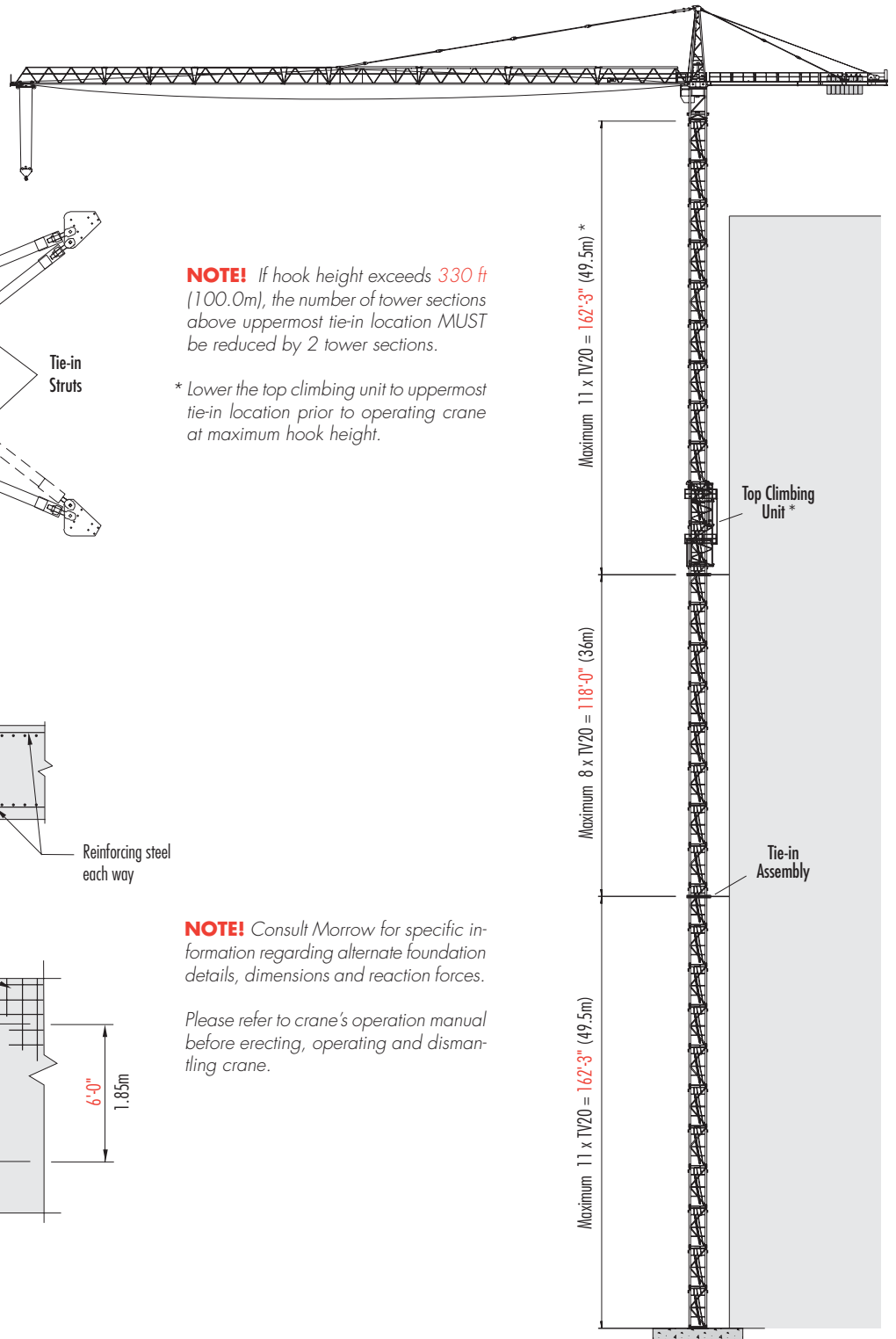

Maximum 11 x TV20 = 162'-3" (49.5m)\*

Maximum 8 x TV20 = 118'-0" (36m)

Maximum 11 x TV20 = 162'-3" (49.5m)

Top Climbing Unit \*

Tie-in Assembly

**NOTE!** Consult Morrow for specific information regarding alternate foundation details, dimensions and reaction forces.

Please refer to crane's operation manual before erecting, operating and dismantling crane.

**TOP CLIMBING**  
with TV 20 Tower Sections  
(Tied to Structure)

# Radius & Capacities

# Wolffkran 325 SL

Hook Radius	4-Part Line		2-Part Line		ft	66	98	115	125	131	140	148	155	164	170	180	197	213	230	246*
	Max Capacity – Radius		Max Capacity – Radius		m	20	30	35	38.1	40	42.7	45	47.2	50	51.8	55	60	65	70	75
246 ft* 75m	246-ft hook reach is available only when using 2-part line operation!		13,230 lbs – 101 ft 6 000 kg – 30.8m		lbs	13,230	13,230	11,400	10,495	9,700	9,305	8,400	8,005	7,295	7,100	6,395	5,710	5,095	4,495	4,000
230 ft 70m	26,460 lbs – 67 ft 12 000 kg – 20.4m		13,230 lbs – 124 ft 6 000 kg – 37.8m		lbs	26,460	17,110	14,310	13,095	12,190	11,400	10,605	9,900	9,305	8,795	8,200	7,295	6,590	6,000	
213 ft 65m	26,460 lbs – 70 ft 12 000 kg – 21.3m		13,230 lbs – 129 ft 6 000 kg – 39.4m		lbs	26,460	18,100	15,190	13,690	13,005	11,995	11,310	10,495	9,900	9,500	8,795	7,805	7,100		
197 ft 60m	26,460 lbs – 72 ft 12 000 kg – 21.9m		13,230 lbs – 132 ft 6 000 kg – 40.3m		lbs	26,460	18,695	15,695	14,200	13,405	12,500	11,705	11,000	10,295	9,810	9,105	8,200			
180 ft 55m	26,460 lbs – 76 ft 12 000 kg – 23.2m		13,230 lbs – 141 ft 6 000 kg – 42.9m		lbs	26,460	19,795	16,660	15,190	14,200	13,295	12,390	11,705	10,890	10,405	9,700				
164 ft 50m	26,460 lbs – 79 ft 12 000 kg – 24m		13,230 lbs – 146 ft 6 000 kg – 44.5m		lbs	26,460	20,700	17,395	15,895	14,905	14,000	13,005	12,300	11,500						
148 ft 45m	26,460 lbs – 83 ft 12 000 kg – 25.3m		13,230 lbs – 148 ft 6 000 kg – 45m		lbs	26,460	21,695	18,210	16,490	15,695	14,595	13,700								
131 ft 40m	26,460 lbs – 83 ft 12 000 kg – 25.4m		13,230 lbs – 131 ft 6 000 kg – 40m		lbs	26,460	22,000	18,495	16,660	15,900										
115 ft 35m	26,460 lbs – 84 ft 12 000 kg – 25.6m		13,230 lbs – 115 ft 6 000 kg – 35m		lbs	26,460	22,290	18,750												
98 ft 30m	26,460 lbs – 87 ft 12 000 kg – 26.5m		13,230 lbs – 98 ft 6 000 kg – 30m		lbs	26,460	23,200													

## Capacity

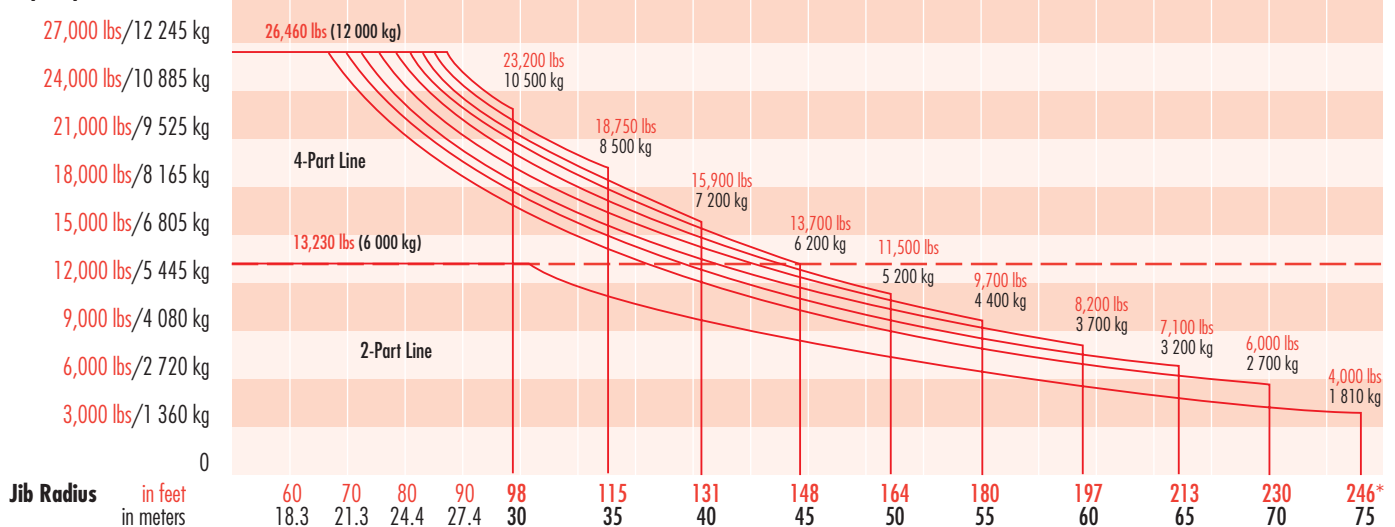

\* **IMPORTANT!** If the crane is erected with a 246-ft (75m) jib:

- (1) ONLY 2-part line operation can be used,
- (2) the maximum stationary freestanding hook height is 197 ft/60m (i.e., 13 TV20 tower sections),
- (3) the maximum hook height is 182 ft/55.5m if erected on a KRE 260.2 or a UWV 260.3,
- (4) the maximum hook height is 137.8 ft/42m if erected on a UWV 260.2 undercarriage

For additional information regarding this configuration, consult the Morrow Equipment engineering department.

# SPECIFICATIONS

## Tower crane model WK 325 SL

### Hoist Speed and Capacity

Hoist Unit	Hw 6 86 3	2-Part Line				
		Gear	Capacity	Line Speed	Capacity	Line Speed
115 hp (86.0 kW) AC hoist unit 3-speed gearbox Remote-controlled gear shifting Eddy current brake		1	13,230 lbs @	220 fpm	6 000 kg @	68 m/min
		2	8,820 lbs @	310 fpm	4 000 kg @	94 m/min
		3	4,410 lbs @	550 fpm	2 000 kg @	168 m/min
		4-Part Line				
		1	26,460 lbs @	110 fpm	12 000 kg @	34 m/min
		2	17,640 lbs @	155 fpm	8 000 kg @	47 m/min
		3	8,820 lbs @	275 fpm	4 000 kg @	84 m/min

**NOTE!** Capacities and line speeds indicated will vary depending on the amount of hoist rope installed. This crane model may be equipped with a hoist unit other than that specified in data above. To verify, check the serial number of the crane and refer to the Wollfkran 325 SL Operation Manual for additional information.

### Motor Information

Drive Unit	Horsepower	Kilowatts	Speed	
Trolley (Tw 70 FSG)	9.4 hp	7.0 kW	79/156/315 fpm	24/48/96 m/min
Swing (Dw-FSG)	2 x 9.8 hp	2 x 7.3 kW	0.8 rpm	
Rail Travel (UW 260.2)	2 x 8.8 hp	2 x 6.6 kW	98.5 fpm	30 m/min
Rail Travel (UW 260.3)	4 x 6.4 hp	4 x 4.8 kW	98.5 fpm	30 m/min

### Power Requirements











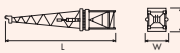

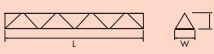



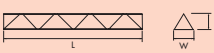



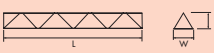
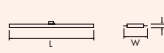

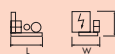
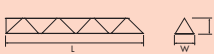

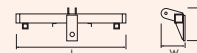

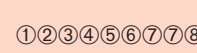

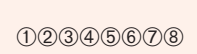

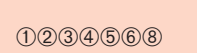

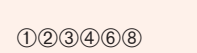

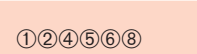
480 Volts — 3-phase — 60-cycle — 200 Amperes service with 115 hp (86 kW) hoist unit

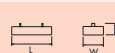
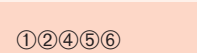
Specifications subject to change without notice. For other configurations and specifications, contact Morrow Equipment.

**Morrow Equipment Co., L.L.C.**

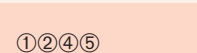
# Component List

# Wolffkran 325 SL

Description	Dimensions L x W x H	Weight	Description	Dimensions L x W x H	Weight
Turntable & Tower Top without Cab	 42'-6" x 7'-11" x 8'-0" 12.96m x 2.42m x 2.45m	26,675 lbs 12 100 kg	Jib Section ①	 33'-6" x 5'-9" x 7'-7" 10.22m x 1.75m x 2.32m	5,840 lbs 2 650 kg
Tower Top	 27'-11" x 4'-6" x 5'-11" 8.5m x 1.36m x 1.8m	8,375 lbs 3 800 kg	Jib Section ②	 33'-6" x 5'-7" x 7'-1" 10.22m x 1.71m x 2.16m	4,300 lbs 1 950 kg
Turntable with Slewing Motors	 19'-5" x 7'-11" x 8'-0" 5.92m x 2.42m x 2.45m	18,300 lbs 8 300 kg	Jib Section ③	 33'-6" x 5'-7" x 7'-1" 10.22m x 1.71m x 2.16m	4,235 lbs 1 920 kg
Turntable Upper Part 1	 7'-5" x 7'-11" x 8'-0" 2.26m x 2.42m x 2.45m	9,700 lbs 4 400 kg	Jib Section ④	 33'-8" x 5'-7" x 7'-1" 10.27m x 1.71m x 2.16m	4,320 lbs 1 960 kg
Turntable Lower Part 2	 12'-0" x 7'-11" x 6'-7" 3.66m x 2.42m x 2.0m	8,600 lbs 3 900 kg	Jib Section ⑤	 17'-5" x 5'-6" x 6'-4" 5.31m x 1.69m x 1.94m	2,070 lbs 940 kg
Counterjib Part 1	 33'-4" x 6'-0" x 2'-0" 10.16m x 1.84m x 0.61m	4,895 lbs 2 220 kg	Jib Section ⑥	 33'-10" x 5'-6" x 6'-4" 10.3m x 1.69m x 1.94m	3,640 lbs 1 650 kg
Counterjib - Part 2 w/fixed counterweight	 32'-10" x 6'-9" x 2'-6" 10.0m x 2.05m x 0.76m	10,095 lbs 4 580 kg	Jib Section ⑦	 17'-2" x 5'-6" x 6'-4" 5.27m x 1.69m x 1.94m	1,585 lbs 720 kg
Hoist Unit — Hw 6 86 3 (115 hp/86 kW) <sup>3</sup>	 7'-9" x 12'-4" x 5'-5" 2.36m x 3.75m x 1.65m	12,785 lbs 5 800 kg	Jib Section ⑧	 33'-7" x 5'-6" x 6'-4" 10.23m x 1.69m x 1.94m	2,710 lbs 1 230 kg
Operator Cab with Access Platform	 7'-3" x 4'-3" x 7'-3" 2.2m x 1.3m x 2.2m	1,430 lbs 650 kg	Jib Tip with Rope Swivel	 5'-5" x 3'-1" x 1'-5" 1.67m x 0.94m x 0.43m	300 lbs 135 kg
Trolley	 7'-3" x 6'-5" x 3'-1" 2.21m x 1.95m x 0.93m	900 lbs 410 kg	Jib Assembly <sup>4</sup> 246-ft (75m)	 ①②③④⑤⑥⑦⑧ 248'-5" x 5'-9" x 7'-7" 75.7m x 1.75m x 2.32m	36,190 lbs 16 415 kg
Hook Block 2/4-part Combination	 4'-2" x 8" x 5'-2" 1.28m x 0.2m x 1.58m	1,500 lbs 680 kg	Jib Assembly <sup>4</sup> 230-ft (70m)	 ①②③④⑤⑥⑦⑧ 232'-0" x 5'-9" x 7'-7" 70.7m x 1.75m x 2.32m	34,600 lbs 15 695 kg
Tower Section TV 20	 15'-11" x 6'-8" x 7'-5" 4.84m x 2.03m x 2.24m	6,600 lbs 3 000 kg	Jib Assembly <sup>4</sup> 213-ft (65m)	 ①②③④⑤⑥⑧ 215'-7" x 5'-9" x 7'-7" 65.7m x 1.75m x 2.32m	32,950 lbs 14 945 kg
Tower Section TV 25	 15'-11" x 8'-3" x 8'-3" 4.84m x 2.51m x 2.51m	6,920 lbs 3 140 kg	Jib Assembly <sup>4</sup> 197-ft (60m)	 ①②③④⑥⑧ 199'-2" x 5'-9" x 7'-7" 60.7m x 1.75m x 2.32m	30,800 lbs 13 970 kg
Transition Section TVUE 20	 15'-11" x 8'-3" x 8'-3" 4.84m x 2.51m x 2.51m	7,935 lbs 3 600 kg	Jib Assembly <sup>4</sup> 180-ft (55m)	 ①②④⑤⑥⑧ 182'-8" x 5'-9" x 7'-7" 55.7m x 1.75m x 2.32m	27,500 lbs 12 475 kg
Counterweight Block A	 4'-8" x 1'-6" x 7'-3" 1.42m x 0.45m x 2.2m	6,800 lbs 3 085 kg	Jib Assembly <sup>4</sup> 164-ft (50m)	 ①②④⑥⑧ 166'-4" x 5'-9" x 7'-7" 50.7m x 1.75m x 2.32m	25,300 lbs 11 475 kg
Counterweight Fixed Block	 6'-8" x 4'-8" x 1'-5" 2.03m x 1.42m x 0.43m	4,410 lbs 2 000 lbs	Jib Assembly <sup>4</sup> 148-ft (45m)	 ①②④⑤⑥ 149'-11" x 5'-9" x 7'-7" 45.7m x 1.75m x 2.32m	24,700 lbs 11 205 kg
Central Ballast Block A (for KRE/UW260.2, UW260.3)	 12'-6" x 1'-8" x 5'-2" 3.8m x 0.5m x 1.57m	11,025 lbs 5 000 kg	Jib Assembly <sup>4</sup> 131-ft (40m)	 ①②④⑥ 133'-6" x 5'-9" x 7'-7" 40.7m x 1.75m x 2.32m	22,600 lbs 10 250 kg
Central Ballast Block B (for KRE/UW260.2, UW260.3)	 12'-6" x 10" x 5'-2" 3.8m x 0.25m x 1.57m	5,512 lbs 2 500 kg	Jib Assembly <sup>4</sup> 115-ft (35m)	 ①②④⑤ 117'-1" x 5'-9" x 7'-7" 35.7m x 1.75m x 2.32m	21,000 lbs 9 525 kg
Top Climbing Unit KWH 20.3	 34'-7" x 8'-4" x 9'-0" 10.54m x 2.53m x 2.75m	17,635 lbs 8 000 kg	Jib Assembly <sup>4</sup> 98-ft (30m)	 ①②④ 100'-8" x 5'-9" x 7'-7" 30.7m x 1.75m x 2.32m	18,800 lbs 8 530 kg
Top Climbing Unit KWH 20.S	 34'-7" x 8'-4" x 9'-0" 10.54m x 2.53m x 2.75m	23,485 lbs 10 650 kg	Crossframe KRE 260.2	 19'-8" x 19'-8" x 14'-2" 6.0m x 6.0m x 4.32m	24,000 lbs 10 885 kg

<sup>1</sup> Includes race bearing, gearboxes and motors.

<sup>2</sup> Does not include race bearing.

<sup>3</sup> Does not include wire rope.

<sup>4</sup> Jib assemblies include jib sections, pendants, trolley and trolley rope.

**NOTE:** Weights and dimensions are approximate. Scale components before lifting.



**Morrow Equipment**  
C O M P A N Y, L. L. C.

3218 Pringle Road SE • P O Box 3306 • Salem, Oregon 97302-0306 USA  
Tel. 503.585.5721 • Fax. 503.363.1172 • www.morrowequipment.com

The American home of  
**LIEBHERR**

Atlanta, GA • Charlotte, NC • Chicago, IL • Denver, CO • Honolulu, HI • Houston, TX • Los Angeles, CA • Las Vegas, NV  
Millwood, NY • St. Louis, MO • San Francisco, CA • Dallas, TX • Seattle, WA • Miami, FL • Tampa, FL • Washington, DC  
Sydney, Australia • Wellington, New Zealand • Vancouver, BC, Canada • Toronto, ON, Canada • México DF, México