

# Mobile Crane

# LTM 1200-5.1

Max. lifting capacity: 200 t  
Max. lifting height: 101 m  
Max. working radius: 80 m

**LICCON2**



# LIEBHERR

# Mobile Crane LTM 1200-5.1

## Flexible and economical to operate



A long telescopic boom, high capacities, an extraordinary mobility as well as a comprehensive comfort and safety configuration distinguish the mobile crane LTM 1200-5.1 from Liebherr. The 200-tonne crane offers state of the art technology for more convenience in practical operation.

- **72 m long telescopic boom and 7 m telescopic boom extension**
- **12.2 m – 36 m long folding fly jib, hydraulically adjustable (option)**
- **Capacity 10.6 t at the 72 m long telescopic boom**
- **Great flexibility of use due to optimum lifting capacities with full and partial ballast**
- **Active, speed-dependent rear-axle steering**
- **Pneumatic disc brakes**
- **LICCON2-control with mobile control and display unit BTT**



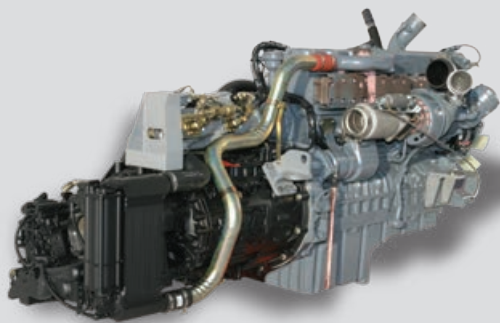

#### Drive train

- 6-cylinder Liebherr turbo-diesel engine, 370 kW/503 HP, max. torque 2355 Nm
- Automated ZF-AS Tronic gearbox, 12 forward and 2 reverse speeds
- ZF intarder directly at the gearbox
- 2-stage transfer case, 0.5 km/h crawling speed
- Axles 2, 4 and 5 driven, axle 1 as option

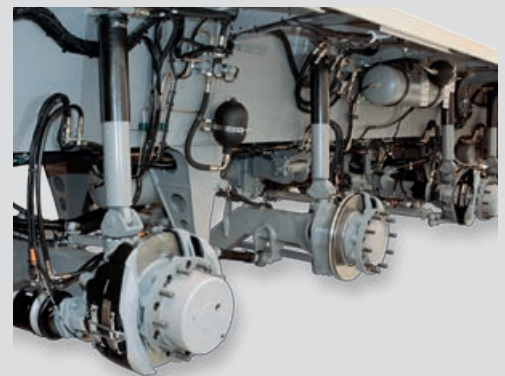

# Most modern chassis and drive technology



## High mobility and efficiency

A high performance 6-cylinder Liebherr turbo diesel engine with 370 kW/503 HP provides for dynamic driving performance. The automatic 12-speed power shift system ZF-AS Tronic with intarder provides a high level of cost effectiveness and excellent comfort.

- Reduced fuel consumption due to the large number of gears and the high efficiency of the dry clutch
- Excellent manoeuvrability and minimum crawling speed thanks to two-stage transfer case
- Wear-free braking with ZF intarder
- Telma eddy current brake optional, wear free and comfortable

## Compact, mobile and weight-optimised

Thanks to its compact design, the LTM 1200-5.1 can operate on the smallest of construction sites.

- Chassis length 13.38 m
- Smallest turning radius 11.0 m
- Vehicle width 3.0 m, with tyres 445/95 R 25 (16.00 R 25)
- Ballast radius 4.85 m

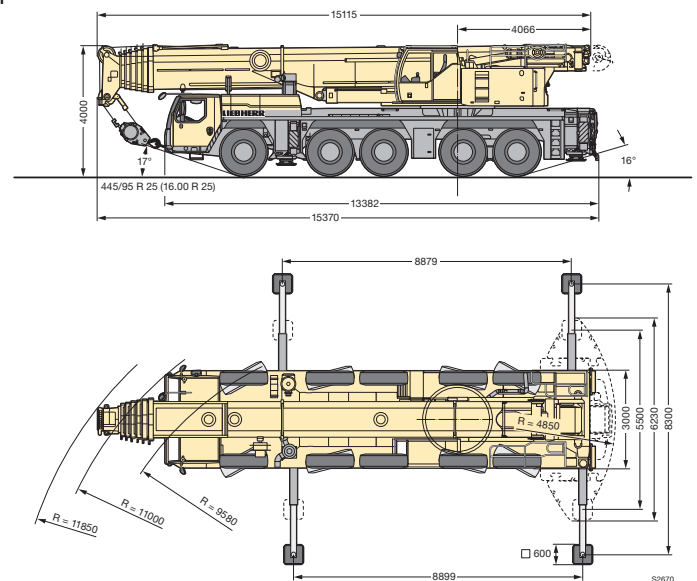

## Hydro-pneumatic suspension “Niveaumatik”

- Maintenance-free suspension cylinders
- Large dimensions to cope with high axle loads
- Spring travel +150/-150 mm
- High lateral stability when cornering
- Choice of driving states using fixed programmes



## Pneumatic disc brakes

- Higher braking power, better brake control
- Improved track stability
- No brake fading at higher operation temperatures
- Higher service life
- Shorter working times for changing of the brake pads
- Brake pads with wear indication



#### Five steering programmes

- Selection of programme by simple push button
- Clear arrangement of control elements and displays
- Programmes can be switched while driving
- Crab steering controlled in comfort via the steering wheel

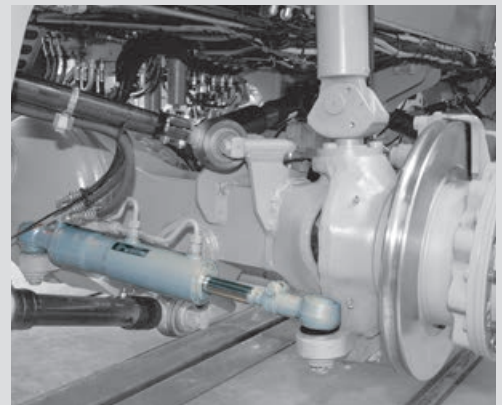

# Variable steering concept



## Centring cylinder to straighten rear axles

- Automatic straightening of rear axles in case of failure

## Active rear-axle steering

The rear axles are electro-hydraulically actively steered depending on the speed and the steering angle of the front axles. Five different steering programmes (P) can be selected by push button.

- Distinct reduction of the tyre wear
- Improvement of the manoeuvrability
- Stable driving performance even at high speeds
- All 5 axles steerable

## High safety standards - entire know-how from Liebherr

- Centring cylinder for automatic straightening of rear axles in case of failure
- Two independent hydraulic circuits with wheel- and engine driven hydraulic pump
- Two independent control computers

### P1 Road steering

Axes 1 and 2 are steered mechanically using the steering wheel. Axes 3, 4 and 5 are actively steered, depending on speed and the front axles lock angle. At speeds of 30 km/h and over, axes 3 and 4 are set to straight-ahead position and locked; at 60 km/h and over, axle 5 is locked in the same forward position.



### P2 All-wheel steering

The axes 3, 4 and 5 are turned depending of the axle lock of the front axles by the steering wheel so far that smallest turning radii are achieved.

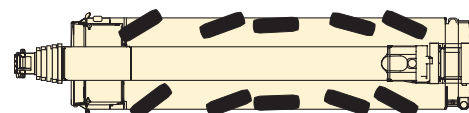

### P3 Crab steering

Axes 3, 4 and 5 are turned in the same direction as the wheel lock on axes 1 and 2 using the steering wheel.

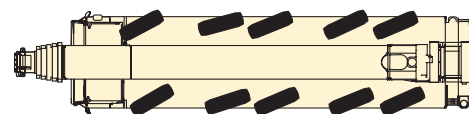

### P4 Reduced swing out

The axes 3, 4 and 5 are turned depending on the axle lock of the front axles, so that the swing out of the chassis rear gets minimized.

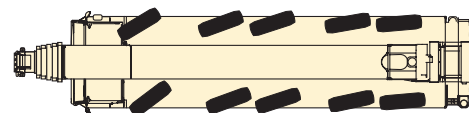

### P5 Independent rear-axle steering

The axes 1 and 2 are turned by using the steering wheel; the axes 3, 4 and 5 are steered by push button independently from the axle lock of the axes 1 and 2.

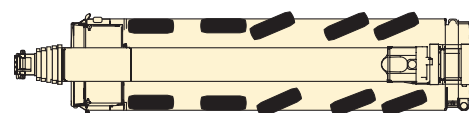



#### **The driver's cab**

- Corrosion resistant
- Safety glass on all sides
- Tinted glass
- Electric window lifters
- Heated and electronically adjustable outside mirrors
- Air-sprung driver's seat with lumbar support



# Comfort and functionality

## Modern driving cab and crane cab

The modern driving cab as well as the backwards tiltable crane cab offer a comfortable and functional working place. The control elements and displays are arranged according to ergonomic factors. Thus a safe and wear free working is assured.

## Speedy and safe set-up

The supporting, ballast assembly and attachment of additional equipment have all been designed with speed, safety and comfort in mind. Specific ascents, handholds and rails are provided to ensure the safety of operating staff.



### Supporting crane on outriggers – quick, comfortable and safe

- BTT blue tooth terminal, mobile control and display unit
- Electronic inclination display
- Fully automatic levelling by push button
- Engine start/stop and speed control
- Support area lighting with four integrated lights
- Support cylinder stroke: front 650 mm, rear 700 mm
- Outrigger beams 2-stage, fully hydraulic, low-maintenance extension system

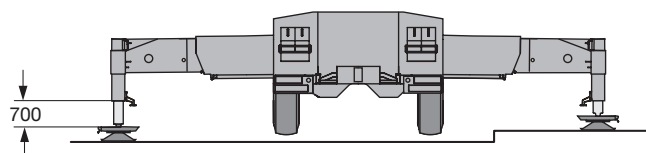

### The crane cab

- Large field of vision
- Safety glazing
- Tinted window panes
- Crane driver's seat with lumbar support, multiply adjustable
- Heat and noise insulated interior cladding
- Corrosion resistant
- Working floodlight
- Can be tilted 20° backwards

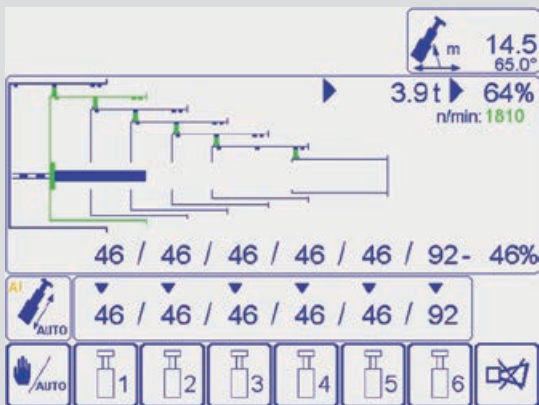
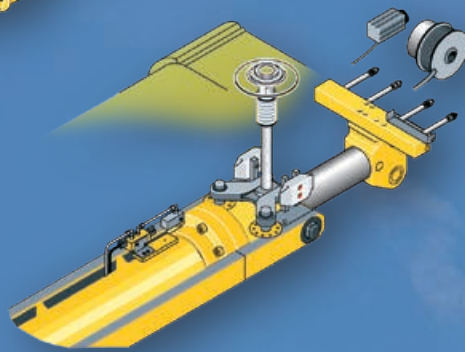
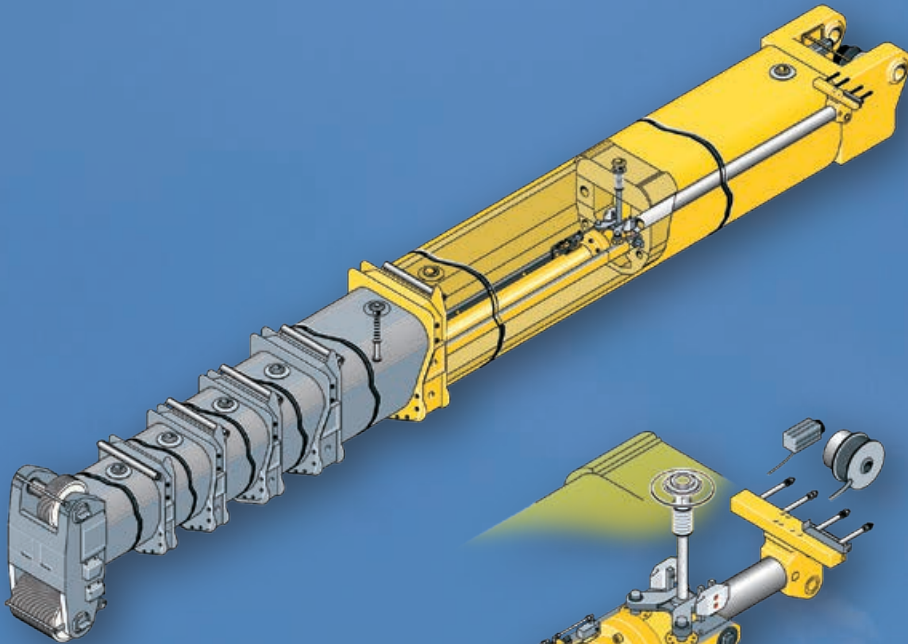
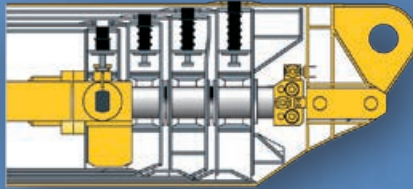
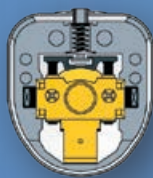

### The fully automatic telescoping system „TELEMATIK“

- Greater lifting capacities with longer booms and larger radii thanks to ‚light‘ telescoping system
- One-stage hydraulic cylinder with hydraulically operated drive pin
- Maintenance-free telescoping system
- Fully automatic telescoping
- Easiest control and monitoring of telescoping action on LICCON screen

### 5.4 m long assembly jib



# High lifting capacities and flexible boom system

## Powerful, long telescopic boom and functional lattice extensions

The telescopic boom consists of the base section and 6 telescopic sections, which can be comfortably and automatically extended and pinned to the requested length by the thousand fold proven single cylinder telescoping system TELEMATIK.

- 72 m long telescopic boom
- 12.2 m – 36 m long double swing-away jib, attachable at 0°, 22.5° and 45°
- Hydraulic adjustment of the swing-away jib at full load from 0° to 45° (optional), interpolation of capacities
- Hydraulic assistance for assembly of the swing-away jib with BTT
- Intermediate section 7 m for extension of the telescopic boom for operation with swing-away jib

## High lifting capacities both with full and partial counterweight offer a wide operational range

- High lateral stability due to the oval boom profile
- Optimized capacities due to the numerous extension variations
- Capacity 10.6 t at 72 m long telescopic boom

## High capacities at unpinned telescopic lengths

- High telescopable capacities due to interpolation
- Separate charts for holding of the load at unpinned telescopic lengths
- Display at LICCON monitor

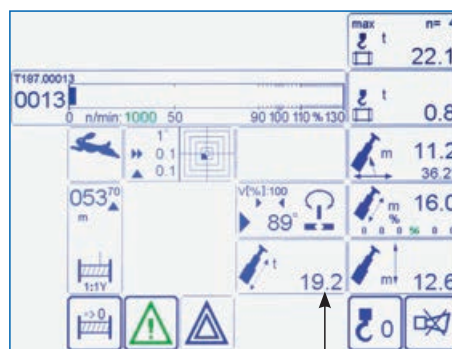

← Holding capacity

← Unpinned telescopic length

← Telescopable capacity

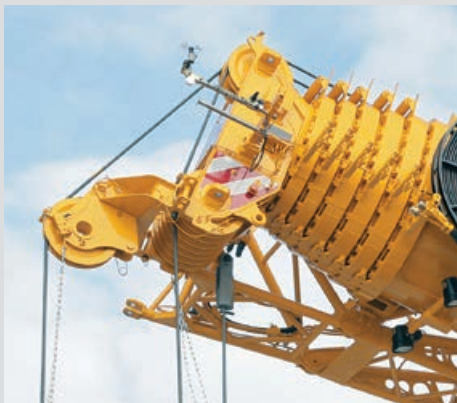

Rooster sheave, foldable sidewise

Hydraulic assistance for assembly of the swing-away jib with BTT



# Hydraulic folding jib

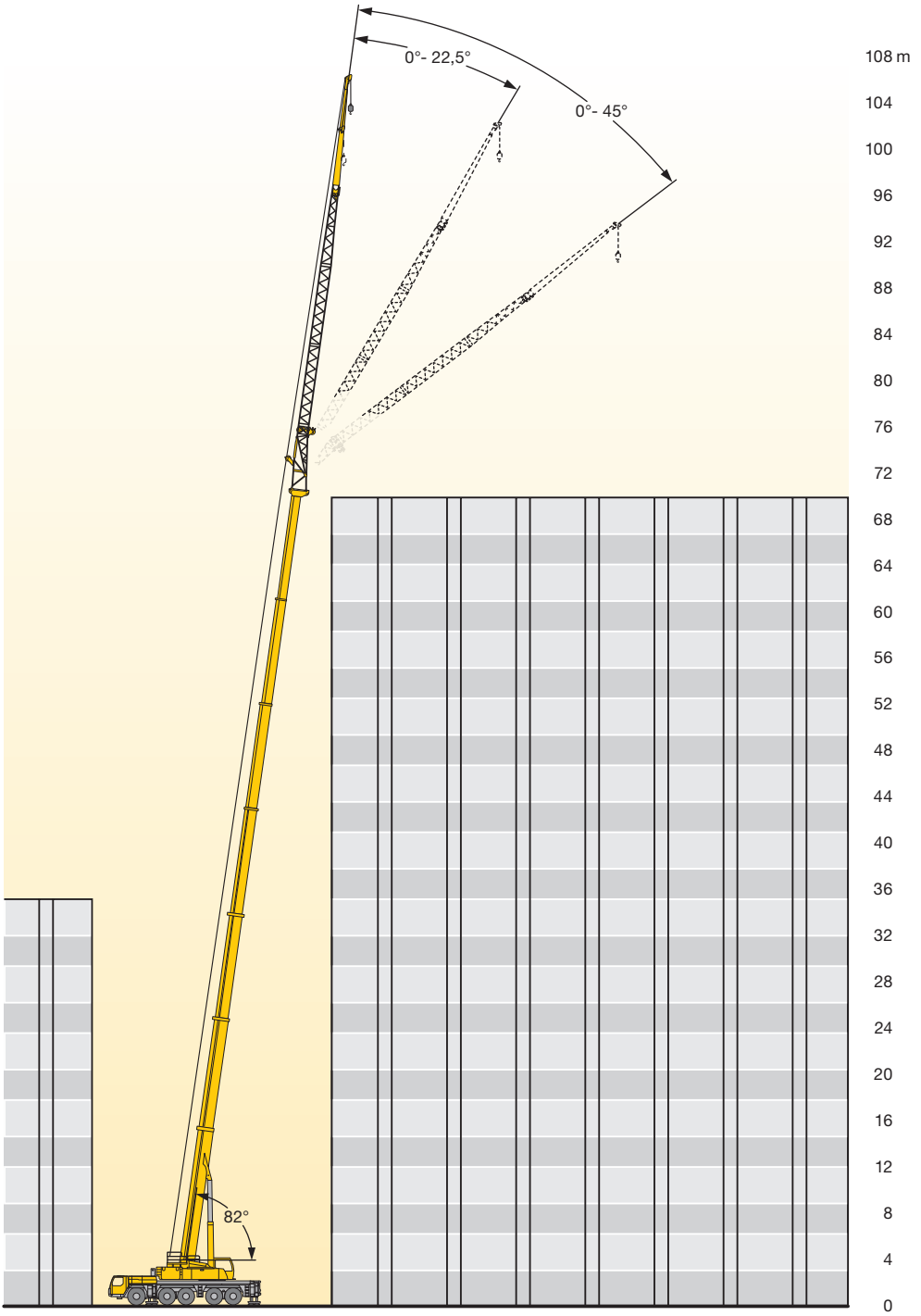

Adjustable folding jib ( $0^\circ$  to  $45^\circ$ )



Hose reel for the hydraulic cylinder



# Variable counterweight

## Counterweight assembly - a matter of minutes

- Multiple counterweight variations from 0 t to 72 t
- Rapid ballasting with keyhole technology from within the crane cab
- Compact counterweight dimensions, at 52 t ballast only 3.75 m ballast width
- Tail swing only 4.85 m

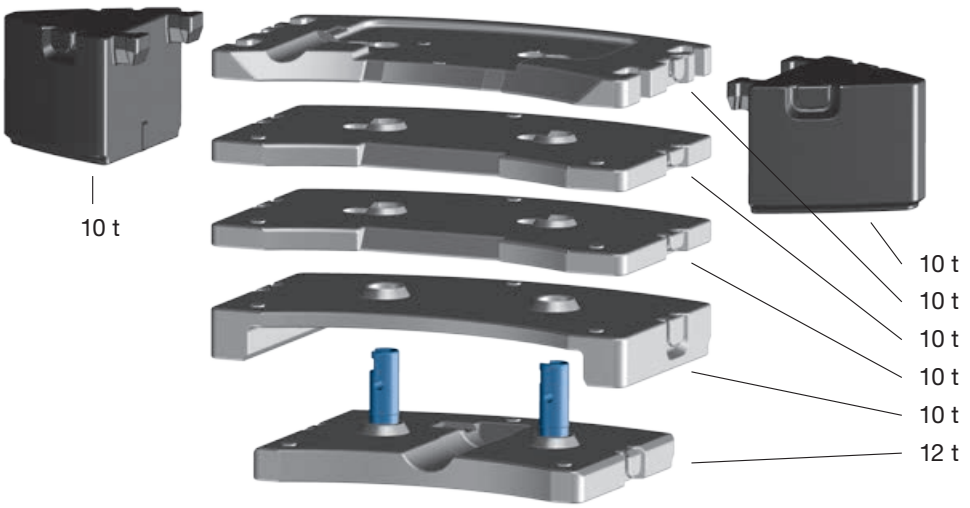

Total ballast 72.0 t

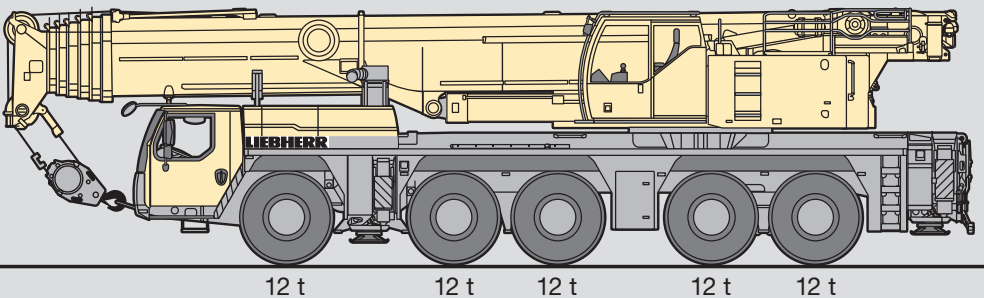

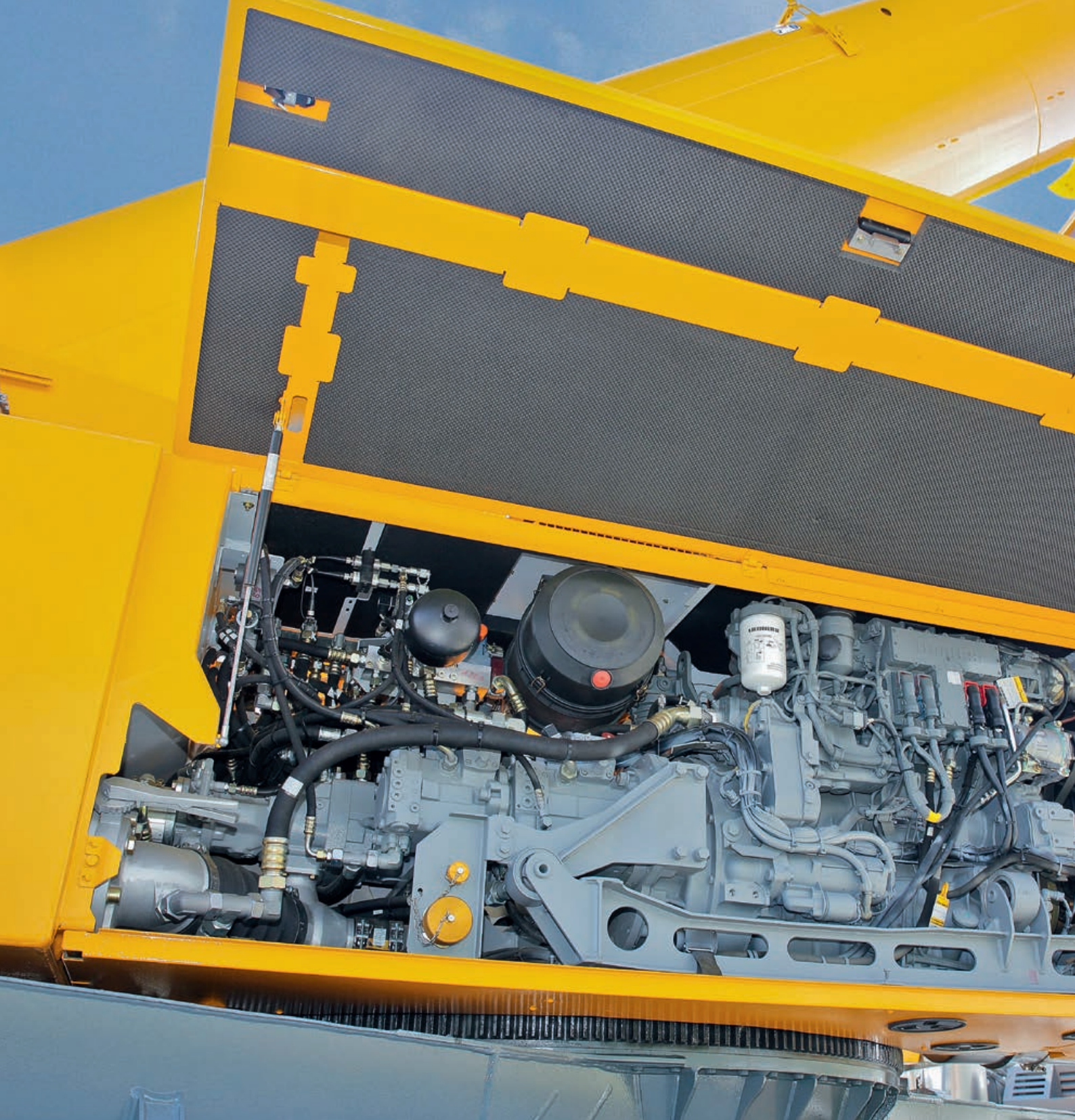

#### The hoist gear

- Liebherr hoist winch with internal planetary gear and spring loaded multi disk brake
- Rope pull 105 kN at the outer layer
- Max. rope speed 140 m/min
- 2. hoist gear optional



# High-power crane drive

## With tried-and-tested components

The drive components for crane operation are constructed for high performance and ensure sensitive and precise load handling. They are specially designed to suit the crane's usage and have been subjected to hard endurance tests.

- Crane engine: 4-cylinder Liebherr turbo diesel engine, 145 kW/197 HP, max. torque 926 Nm, optimized fuel consumption by electronic engine management
- Sensitive motions of the hoist gears in closed hydraulic circuits
- Electric/electronic SPS-crane control via the LICCON-computer system
- In-house fabricated Liebherr winches, 105 kN rope pull at the outer layer, less reeving necessary due to high line pull

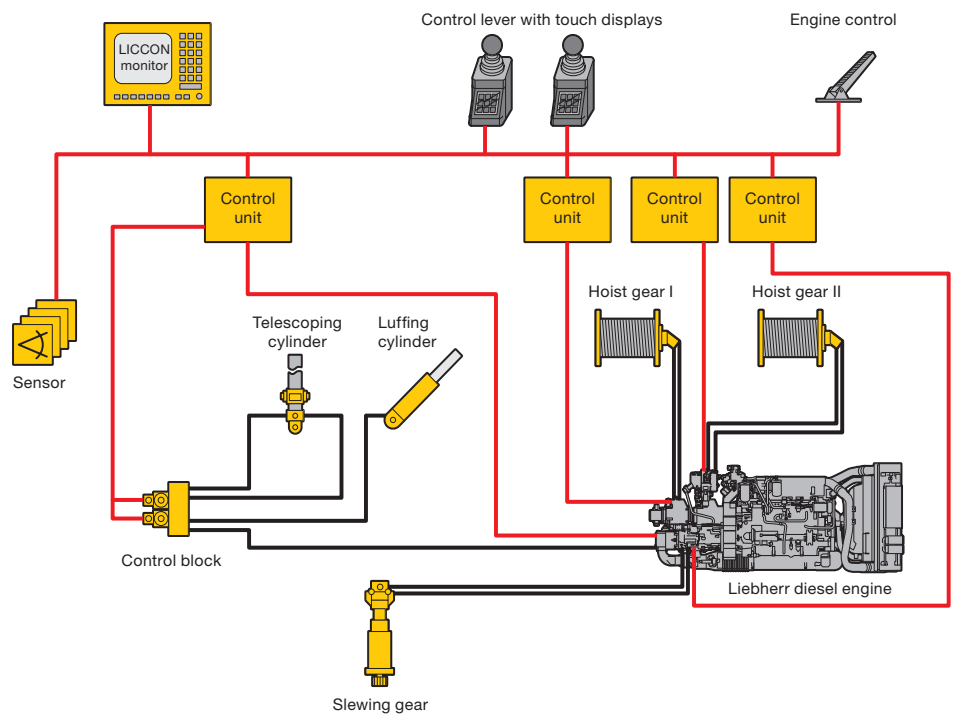

### The slewing gear

- Liebherr planetary gearbox, spring loaded multi disk brake
- Sensitive motions in closed hydraulic circuit
- Slewing speed from 0 – 1.3 min<sup>-1</sup> infinitely variable



### The central greasing

- Standard central greasing device for slewing bearing, boom bearing, luffing cylinder and winch bearing
- Even supply of grease
- Filling quantity visible at any time in transparent reservoir



LICCON  
 BSE-TESTSYSTEM - VERSION 17784  
 009978/0800 2811-07-15 15:23  
 (c) LIEBHERR-WERK EHINGEN 2011 MEST 08:07:41 2011-07-21

LICCON Datenlogger II V1.51  
 KW: 00000969  
 QVART: V 01.28.04  
 18.8.57.109

> SPRACHE: DEUTSCH <

FEHLER ÜBR SCHEIN SERVICE  
 SHOTS LÖSUNG

### The LICCON test system

- Rapid localisation of problems without any other measuring instruments
- Error code and description displayed
- Convenient interactive functions for monitoring all inputs and outputs
- Displays functions and allocation of sensors and actuators

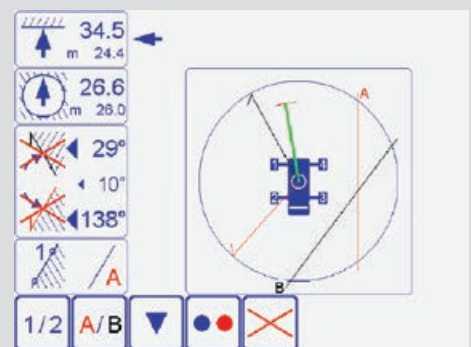



# Intelligent crane control

## For functional and safe crane operation: the LICCON computer system

The soft and hardware of the mobile crane control is developed by Liebherr in-house. The centre is the LICCON computer system (Liebherr Computed Control).

- Integrated LML load moment limiter
- Key components are in-house manufactured by Liebherr
- Guaranteed spare parts availability
- Worldwide proven under the most different climate conditions
- Operator friendly

The second control generation LICCON2 is the result of a continuous development by the Liebherr specialists and enables the adaption to the constantly increasing demands of the markets due to its modern and future oriented control.

## The data bus technology

Liebherr mobile cranes are completely interlaced by the data bus system. All important electric and electronic components are equipped with own micro processors and communicate with each other by only limited data cables. For the special demands of the mobile crane Liebherr has developed own data bus systems (LSB – Liebherr-System-Bus). The data bus technology improves the reliability, the comfort and the safety for road driving and crane operation:

- Higher reliability due to remarkable lesser electric cables and contacts
- Continuous self testing of the “intelligent sensors“
- Comprehensive diagnosis possibilities, fast fault finding



### The LICCON working range limiting system

- Makes the crane operator's job easier by automatically monitoring workspace restrictions such as bridges, roofs, etc.
- Simple programming
- Four different limitation functions:
  - Pulley-head height limitation
  - Radius limitation
  - Slewing angle limitation
  - Edge limitation

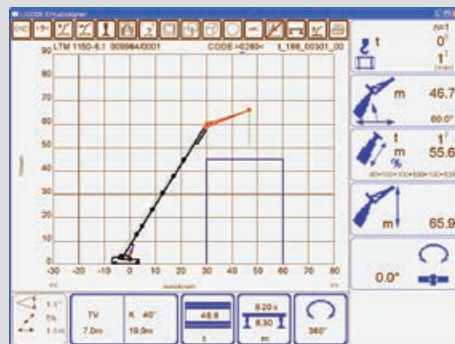

### The LICCON work planner

- Computer programme for planning, simulating and documenting crane operations on a PC
- Representation of all the crane's load charts
- Automatic search for suitable crane based on load, radius and lifting height parameters
- Simulation of crane operations with outline functions and supporting force display

# LICCON2 - safe and comfortable



## Attaching and detaching of the hook block

The BTT Bluetooth Terminal offers the crane driver the possibility to attach or detach the hook block at the front of the vehicle within sight, as the hoist winch and the luffing cylinder of the telescopic boom are remote controlled.



Wireless remote control

## Wireless remote control (option)

All crane motions can be controlled outside of the cab.

- Higher efficiency
- Free view and closeness to the load
- Prevention of communication errors between the crane driver and the job site personnel

## Supporting the crane

By use of the BTT the mobile crane will be setup comfortably and safely. Engine start/stop and speed regulation, electronic inclination display and automatic levelling are standard. Optionally the BTT can also display the outrigger forces.



## Colour monitor

The readability of the data on the monitor of the LICCON2 control system in the crane cab is enhanced by the colour display. Warnings and crane utilization are considerably better recognized.



## Touch displays

Below the joy sticks integrated in the armrests the touch displays are installed, with which the various operational functions can be selected. These are beside others the supporting of the crane, the adjustment of the working floodlights as well as heater and air condition controls.