

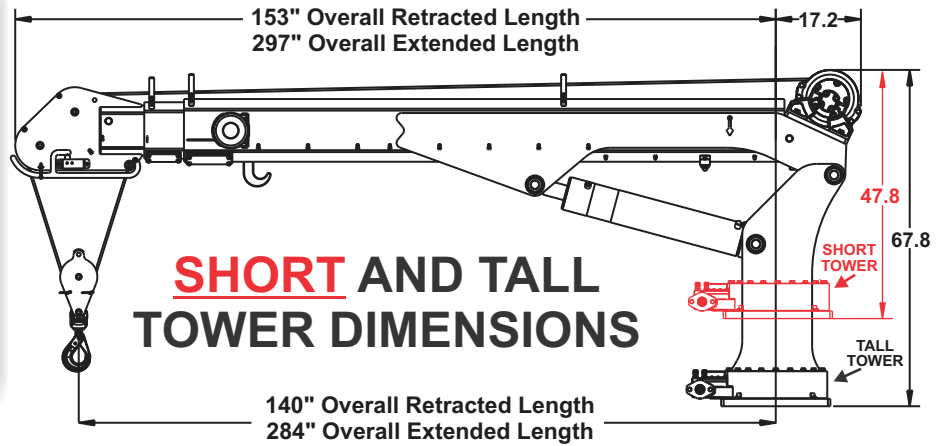

H10025 CRANE

Maintainer

specifications



specifications

- 2371 lbs. (998 KGS)
- 22" x 22" Mounting Space Required
- Mounting requires (8) 7/8-9 (GRD-8) bolts
- Hydraulic Requirements: 10-12 GPM@3000 PSI



features

- 10,000 lb. max. capacity
- 75,000 ft-lb capacity
- 25' hydraulic reach
- Boom-Mounted planetary winch
- Dual part line standard - single part capable
- Total operational range 91° (-13 to +78)
- Low profile double sheave design
- Anti-Two block relocation (left side)
- User-Friendly load block storage
- 140' of 3/8" diameter wire rope
- 615° of rotation
- Hexagonal boom
- Tall and short tower configurations
- Closed-center/load sensing hydraulic system (open center optional)
- OSHA 1910.180/ANSI B30.5 compliant
- LMI feature - standard
- Wireless remote - standard

ratings

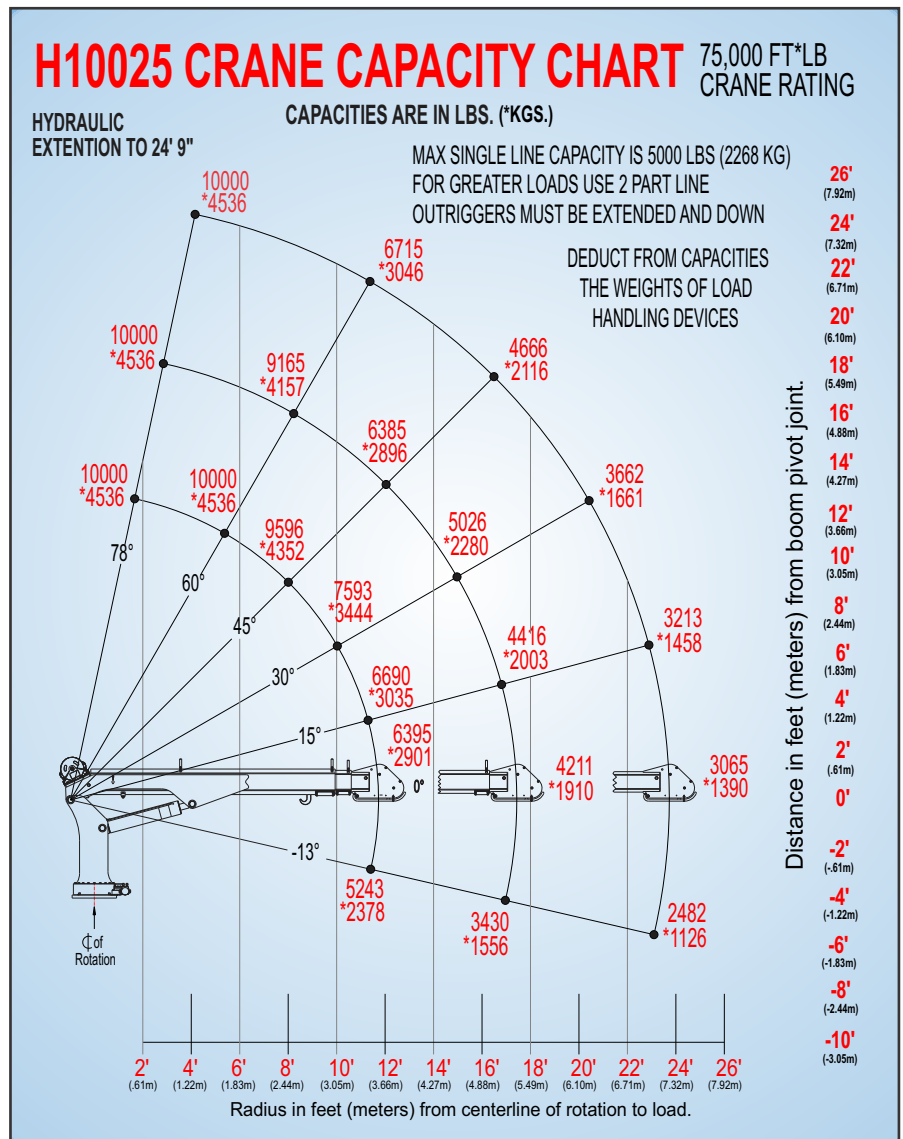

MAINTAINER CORPORATION OF IOWA, INC.
1701 S. 2nd Avenue Sheldon, Iowa 51201
Ph: 800-831-8588 Fax: 712-324-3526 www.maintainer.com