

LORAIN MC-7125

MOTO-CRANE™

specifications
dimensions
work ranges
lift capacities

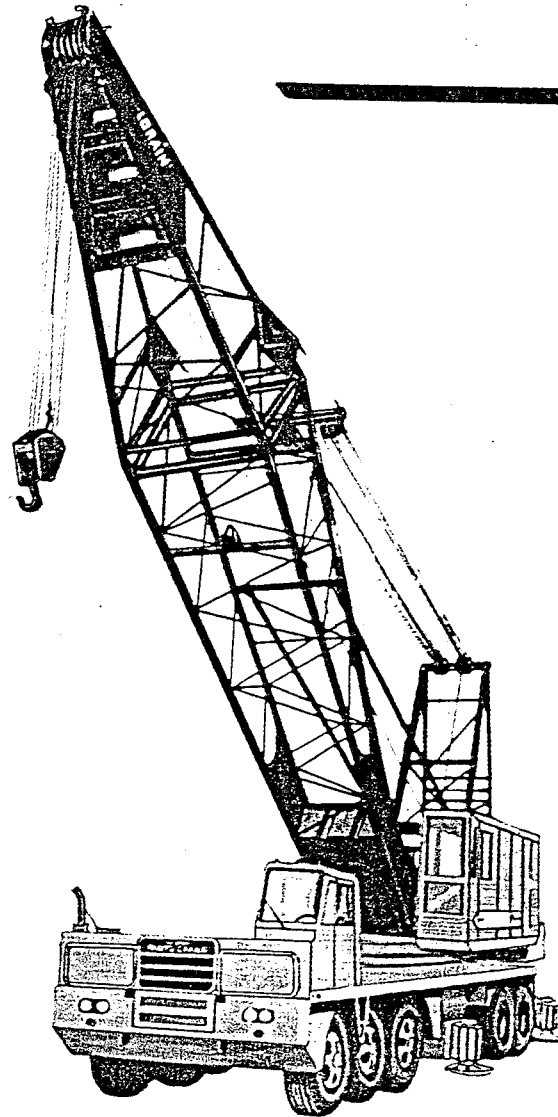

FEATURES:

- Preferred Square Tubular Chord Boom
- Choice of Three Peaks — Offset, Tapered, Hammerhead
- 300'-Boom and Jib Combination
- Dual Drum Boom Hoist
- Tandem Hoist Drums—Super Spooling Capacity
- Tower Available
- Enclosed All Gear Drive
- Metered Air Controls
- Independent Hydraulic Swing
- 10-Year Warranted "Shear-Ball" Turntable Connection
- Performance Matched Lorain-Built Carrier
- Easy Weight Reduction

GENERAL DIMENSIONS:

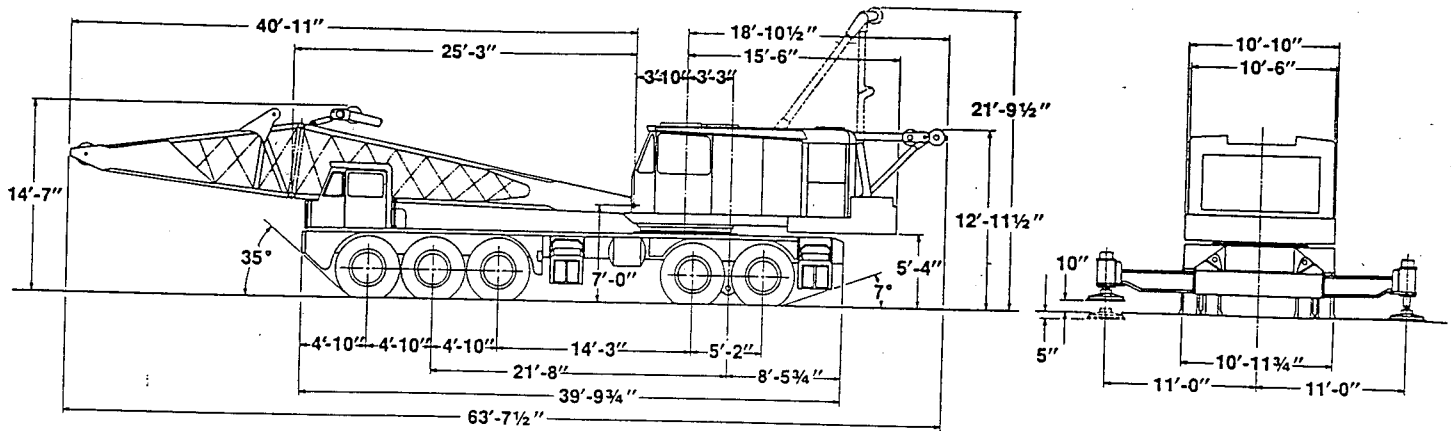

**MC-7125 (10x4)
LOAD DISTRIBUTION**

	Gross Weight	Turntable Facing Front		Turntable Facing Rear	
		Front	Rear	Front	Rear
1. Basic Crane	96550	22580	73970	42290	54260
Less:					
a. Counterweight					
b. Front & Rear Outrigger Boxes and Beams					
c. Complete 40' D-17A Offset Boom, Floating Harness, Boom Hoist Cable & Boom Stops					
d. Hoist Cables					
2. Add: Rear Outrigger Box and Beams (POWRSPAN)	+9500	-2815	+12315	-2815	+12315
3. Add: Front Outrigger Box and Beams (POWRSPAN)	+9500	+5190	+4310	+5190	+4310
4. Add: Counterweight	+22000	-8930	+30930	+15520	+6480
5. Add: Load Hoist Cable, Front Drum	+1165	+65	+1100	+285	+880
6. Add: D-17A Boom Base, Floating Harness, Boom Hoist Cable & Boom Stops	+5805	+5000	+745	-3315	-9120
7. Add: D-17A - 15' Offset Boom Peak	+2645	+5165	-2520	-4495	+7140
8. Add: 23'-6" Mast	+1150	+935	+215	-590	+1740
9. Add: P.L.L. Front Drum	+550	+50	+500	+140	+410
10. Add: P.L.L. Rear Drum	+550	-20	+570	+190	+360
11. Add: 3rd Drum	+1600	+240	+1360	+240	+1360
12. Add: GM 6-71N Engine W/Torque Converter	-550	+175	-725	-340	-210
13. Add: GM 8V-71N Engine to Carrier	-330	-400	+70	-400	+70
14. Add: 125 Ton, 6 Sheave Hook Block to Boom Peak	+2450	+5325	-2875	-4590	+7040
15. Add: 8-1/2 Ton Hook & Ball to Boom Peak	+650	+1410	-760	-1215	+1865

**MC-7125 (10x4)
TRAVELING WEIGHTS
(POWRSPAN)**

Turntable Facing Front		Ctwt.	Outriggers		Boom Peak	* Boom Base	Turntable Facing Rear		Gross Weight
Front	Rear		Rear	Front			Front	Rear	
22580	73970	0	0	0	0	0	42290	54260	96550
27640	74715	0	0	0	0	0	38975	63380	102355
32805	72195	0	0	0	X	X	34480	70520	105000
37995	76505	0	0	X	X	X	39670	74830	114500
35180	88820	0	X	X	X	X	36855	87145	124000
26250	119750	X	X	X	X	X	52375	93625	146000
21085	122270	X	X	X	0	X	56870	86485	143355
30015	91340	0	X	X	0	X	41350	80005	121355
32830	79025	0	0	X	0	X	44165	67690	111855

* Boom Base includes all components listed in item 6.
 X Installed on machine.
 0 Removed from machine.

MC-7125

MOTO-CRANE®

SPECIFICATIONS

TURNTABLE SPECIFICATIONS

Power	
Diesel	Cummins N-855-C, 6 cyl.
Bore and Stroke	5½ in. x 6 in.
Displacement	855 cu. in.
Horsepower	210 H.P.
Power Take-Off	Torque Converter
Fuel Tank	75 gals.

Operating Characteristics

Line Pulls and Line Speeds:	Hand Throttle	Foot Throttle
Rear Drum 31" P.D. Lagging		
1st Layer	22,660# @ 210 F.P.M.	17,830# @ 310 F.P.M.
3rd Layer	20,360# @ 234 F.P.M.	16,000# @ 345 F.P.M.
Front Drum 25" P.D. Lagging		
1st Layer	27,550# @ 169 F.P.M.	21,680# @ 250 F.P.M.
3rd Layer	24,150# @ 193 F.P.M.	19,000# @ 280 F.P.M.
Swing Speed	0 to 4 R.P.M.	

Controls

Hoist and Derricking Clutches	Metered Air
Swing	Independent Hydraulic

Other Equipment

Boom Hoist	Dual Drum
Gantry	Power Operated Back Hitch
Counterweight (with Hydraulic Kit for Removal)	22,000 lbs.

Turntable Connection	Internal Gear Shear-Ball®
----------------------------	---------------------------

MOTO-CRANE SPECIFICATIONS

Power	
Diesel	Cummins NTF-365, 6 cyl.
Bore and Stroke	5½ in. x 6 in.
Displacement	855 cu. in.
Horsepower	365 H.P.
Power Take-Off	Plate Clutch
Fuel Tank	120 gals.

Transmissions

Main	14 Speeds
Auxiliary	3 Speeds
Speeds Forward	42
Speeds Reverse	6

Speeds:	Low-low.....0.8 M.P.H.	High-high.....40.0 M.P.H.
----------------	------------------------	---------------------------

Outriggers.....	POWRSPAN, Hydraulically Operated, Complete with Floats.
------------------------	---

Rear Bogie

Axles (Planetary)	Double Reduction Gear Drive
First reduction thru hypoid gears; final reduction thru planetary wheel hubs; high-traction differentials. Interaxle differentials with lockout.	
Mounting	Two axles in tandem, with "through-drive", mounted on equalizer beams.

Front Tridem.....	Three non-driving axles on equalizer beams
Steering	Centralized, Hydraulic Power Assist
Turning Radius (to Front Corner of Vehicle).....	67 ft.

Brakes (Spring-set for emergency and parking).....	Air
Rear	4 Brakes; 20¼ in. dia. x 7 in. wide
Front	6 Brakes; 17¼ in. dia. x 4 in. wide

Tires (Tube)	14:00 x 24, 24 P.R.
---------------------------	---------------------

Guide Rails for undocking turntable.....	Available
---	-----------

BOOM EQUIPMENT

Crane Boom

Design	Square Tubular Chord
Type of Connection	Pin Connected
Basic Length—Offset Peak Boom.....	40 ft.; 25 ft. base, 15 ft. peak
Hammerhead Peak Boom.....	28 ft.; 25 ft. base, 3 ft. peak
Long Tapered Peak Boom.....	60 ft.; 25 ft. base, 35 ft. peak
Number of Hoist Line Sheaves at Boom Peak on Anti-Friction Bearings	
Offset Peak	6
Hammerhead Peak	6
Long Tapered Peak	5

Jib

Two-Piece* Pin-Connected Type.....	30 ft.; 10 ft. base, 20 ft. peak
*Extendible with 10 ft. & 20 ft. Center Sections to 60 ft.	

Lifting Crane Component

Lagging	31 in. and 25 in. P.D. Full Width
Floating Harness	16 Parts of Line
Boom Stops	Telescopic Type
Swing Brake	Standard
Harness Extending Cylinder	Standard
Speed Retarder	Standard
Power Load Lowering (Both Hoist Drums).....	Available
Third Drum	Available

APPROXIMATE SHIPPING WEIGHTS*

Standard Equipped Machines with Basic Boom	
Lifting Crane (Offset Peak Boom).....	153,035 lbs.
*Total weight of unit may be reduced 22,000 lbs. by taking off removable counterweight for road travel — (hydraulic removal kit included). Additional reductions may be made by removal of outrigger boxes and beams and undocking turntable.	

We reserve the right to amend these specifications at any time without notice. The only warranty applicable is our standard written warranty. **We Make No Other Warranty, Expressed Or Implied.**

MC-7125

REVIEW THE FOLLOWING NOTES BEFORE USING THIS SPECIFICATION TO DETERMINE ALLOWABLE BOOM LENGTHS. RADIUS AND WEIGHT OF LOAD IN POUNDS PERTAIN TO THIS MACHINE AS ORIGINALLY MANUFACTURED AND EQUIPPED.

NOTES:

1. Crane load ratings in pounds as determined by boom length, radius or boom angle apply to the MC-7125 Moto-Crane only as originally manufactured, equipped and mounted on a 10 x 4 Lorain MC-7125 carrier. **THEY ARE MAXIMUM CRANE LOAD RATINGS.**
2. Operating radius is the horizontal distance from the axis of rotation before loading, to the center of the vertical hoist line or tackle with load applied. Crane load ratings are for machines with 22,000 lbs. of counterweight and do not exceed 85% of tipping loads. Ratings identified with asterisk(*) are based on the machine's structural competence and not on the machine stability. Weight of hooks, hook blocks, slings and all other handling devices, except hoist rope shall be considered a part of the load. Crane load ratings with outriggers are based on outrigger fully extended and set to a distance of 11 ft. 0 in. from the longitudinal axis of the carrier to the outrigger float pivot connection and wheels within the boundary of the outriggers. Crane load ratings without outriggers depend on tire capacity and condition of tires inflated to 100 P.S.I.
3. Crane load ratings are based on freely suspended loads with the machine leveled and standing on a firm, uniform supporting surface. Practical working loads depend on supporting surface, wind and other factors affecting stability, hazardous surroundings, experience of personnel and proper handling, all of which must be taken into account by the operator. Positioning or operation at radii and boom or jib lengths beyond the maximum and minimum shown, is not intended or approved.
4. The operator and other personnel should fully read and acquaint themselves with Operator's Manual furnished by the manufacturer BEFORE operating this machine, and Rules for Safe Operation of equipment should be adhered to at all times.
5. This crane and its load ratings are in accordance with Power Crane and Shovel Association Standards No. 1, SAE Crane Load Stability Test Code J-765a, SAE Method of Test for Crane Structure J-987 and Safety Code for Cranes, Derricks and Hoists, ANSI B30.5-1968.
6. All lifting must be done with gantry in raised position.
7. Do not exceed the "over-the-rear" capacities when lifting over a corner.
8. Use blocking under front tires or front part of carrier frame if boom and/or load is to be moved forward of front outriggers.
9. "Without Outriggers" crane load ratings are for over rear and over side as indicated. If loads are to be rotated over the corners of the vehicle, the outriggers should be extended to reduce tire and axle loadings.
10. The total weight of bucket plus load must not exceed 80% of the "Without Outriggers" crane load ratings up to a maximum of 15,000 lbs. for dragline service and 18,000 lbs. for clamshell service.

CRANE WORKING AREAS:

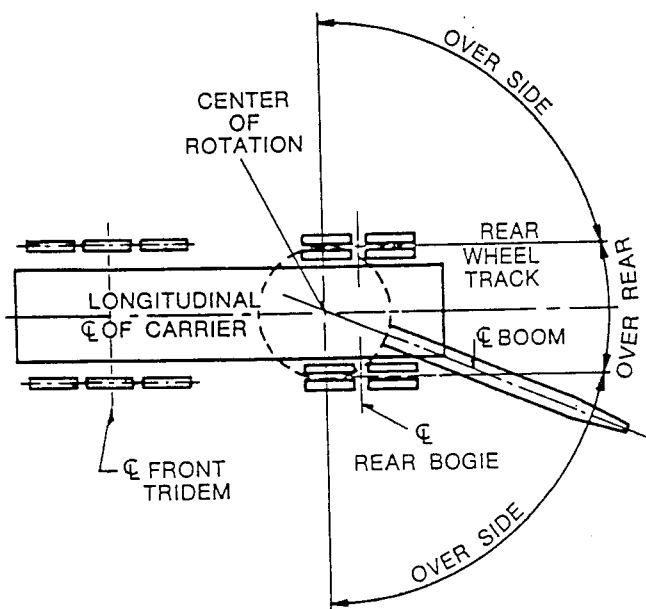

Carrier Without Outriggers

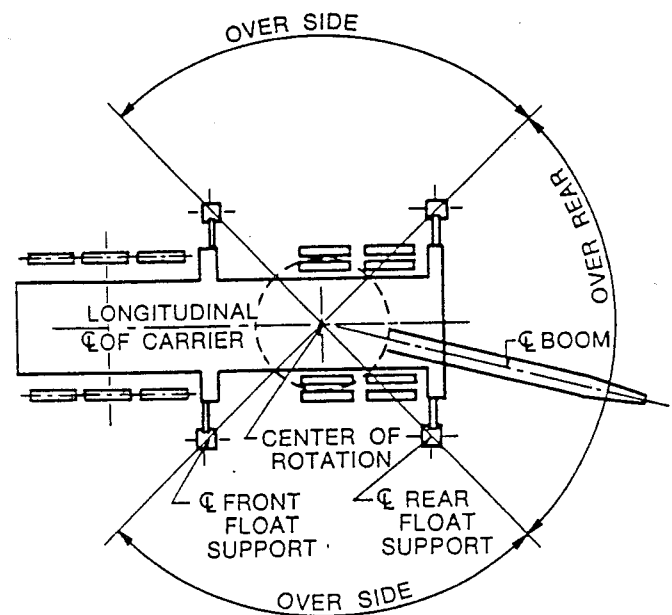

Carrier With Outriggers

Offset Boom Peak

RADIUS DIAGRAM:

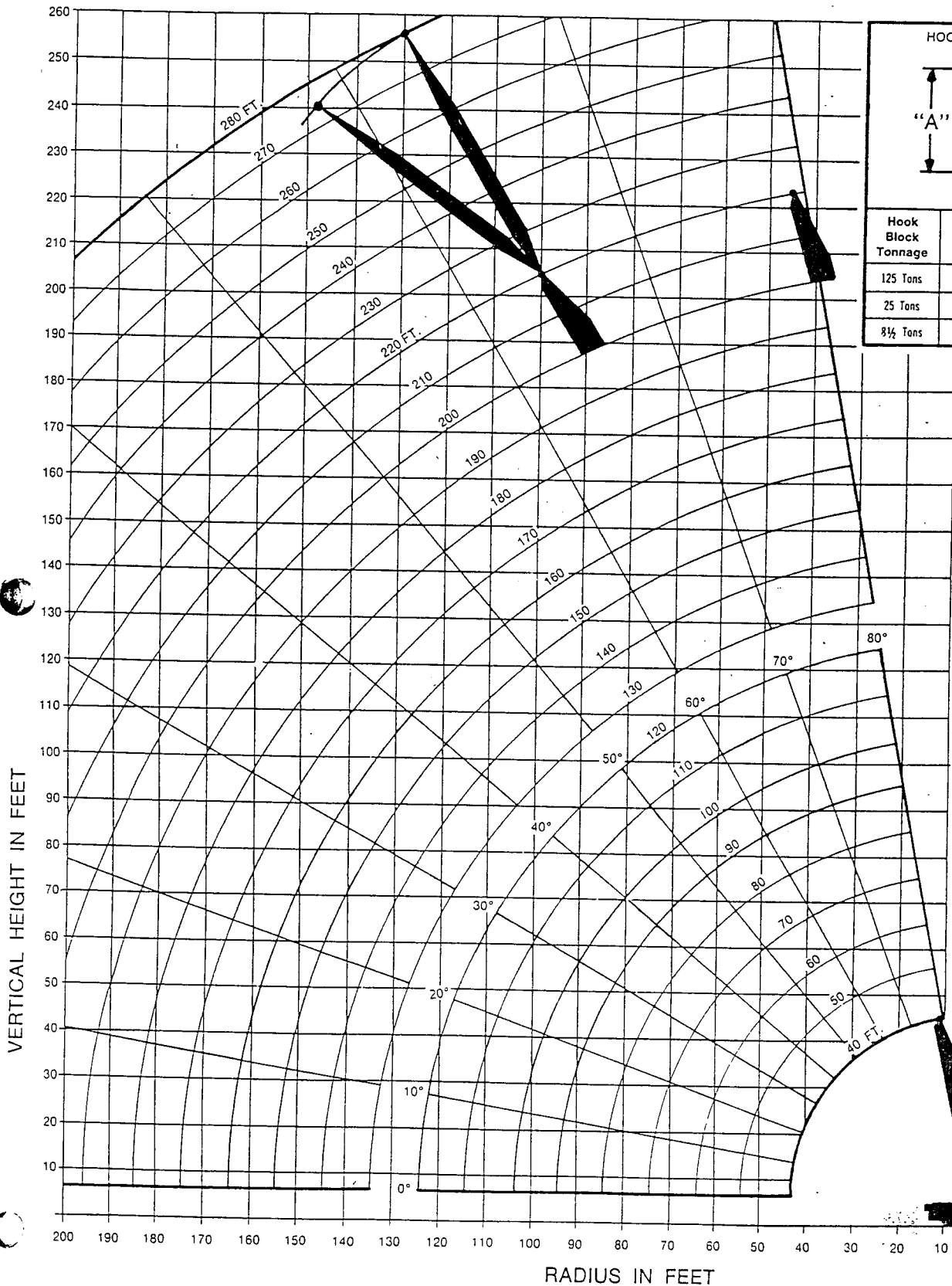

HOOK BLOCK CLEARANCES

Hook Block Tonnage	Number of Sheaves	Hook Block Weight	Dimension "A"
125 Tons	6	2450 Lbs.	12'-0"
25 Tons	1	1145 Lbs.	6'-0"
8½ Tons	None	615 Lbs.	4'-6"

**OFFSET
PEAK BOOM**

**MC-7125
10 X 4**

**P.C.S.A.
12-567**

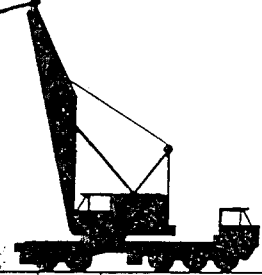

MC-7125

Load Ratings With

CAPACITY CHART:

Maximum Rating

Boom Radius Feet	Boom Angle Degrees	Boom Peak Height Feet	With Outriggers		Without Outriggers	
			Over Rear	Over Side	Over Rear	Over Side
40 Ft. Boom						
12	80.9	46.2	250000*	250000*	125700	114100
15	76.4	45.5	183500*	183500*	92800	81600
20	68.8	43.6	150000*	150000*	64200	54900
25	60.7	41.0	112900*	112900*	48700	41000
30	51.8	37.3	85300*	85300*	39000	32400
40	28.0	24.2	48100*	48100*	27500	22500
50 Ft. Boom						
15	79.2	55.8	169300*	169300*	92600	81400
20	73.2	54.3	149700*	149700*	63900	54700
25	67.1	52.3	120500	120500	48500	40700
30	60.6	49.6	90300	88400	38800	32200
40	45.8	41.6	59400	56700	27300	22300
50	24.8	26.3	39000*	39000*	20800	16700
60 Ft. Boom						
15	81.0	66.0	157700*	157700*	92400	81200
20	76.1	64.8	142500*	142500*	63700	54500
25	71.1	63.2	120200*	120200*	48300	40500
30	65.9	61.0	90000	88200	38600	32000
40	54.7	54.9	59100	56500	27100	22000
50	41.5	45.4	43600	41100	20500	16400
60	22.4	28.2	31700*	31700*	16300	12800
70 Ft. Boom						
20	78.1	75.1	132700*	132700*	63500	54200
25	73.9	73.7	119900*	119900*	48000	40300
30	69.6	71.9	89800	88000	38300	31700
40	60.4	67.0	58900	56300	26900	21800
50	50.2	59.6	43300	40800	20300	16200
60	38.2	48.8	33900	31700	16000	12600
70	20.6	29.9	26300*	25600	13000	10000
80 Ft. Boom						
20	79.7	85.4	123600*	123600*	63300	54000
25	76.0	84.2	113100*	113100*	47800	40000
30	72.2	82.6	89600	87800	38100	31500
40	64.4	78.4	58700	56100	26600	21500
50	56.1	72.4	43100	40600	20000	15900
60	46.7	64.0	33700	31400	15700	12300
70	35.5	52.0	27400	25400	12700	9800
80	19.2	31.5	22100*	21100*	10500	7900
90 Ft. Boom						
20	80.8	95.6	119000*	119000*	63100	53700
25	77.6	94.5	105300*	105300*	47600	39800
30	74.3	93.1	89400	87600	37800	31200
40	67.5	89.4	58400	55800	26300	21200
50	60.3	84.3	42800	40400	19700	15600
60	52.6	77.3	33400	31200	15500	12000
70	43.9	68.0	27100	25200	12500	9500
80	33.4	55.0	22600	20900	10300	7700
90	18.0	33.0	18900*	17600	8600	6200
100 Ft. Boom						
25	78.8	104.8	101200*	101200*	47300	39500
30	75.9	103.5	89200	87400	37500	30900
40	69.8	100.2	58200	55600	26000	21000
50	63.6	95.7	42600	40100	19400	15400
60	56.9	89.8	33200	31000	15200	11700
70	49.6	82.0	26900	24900	12200	9200
80	41.4	71.8	22400	20600	10000	7400
90	31.6	57.8	19000	17400	8300	6000
100	17.0	34.5	16100*	14900	6900	4900

Boom Radius Feet	Boom Angle Degrees	Boom Peak Height Feet	With Outriggers		Without Outriggers	
			Over Rear	Over Side	Over Rear	Over Side
110 Ft. Boom						
25	79.9	115.0	93300*	93300*	47000	39200
30	77.2	113.9	86700*	86700*	37300	30700
40	71.8	110.9	58000	55400	25800	20700
50	66.1	106.9	42400	39900	19200	15100
60	60.3	101.6	32900	30700	14900	11500
70	54.0	94.9	26600	24700	11900	9000
80	47.1	86.4	22100	20400	9700	7100
90	39.4	75.4	18800	17100	8000	5700
100	30.0	60.4	16100	14700	6700	4600
110	16.1	35.8	13800*	12700	5600	3700
120 Ft. Boom						
30	78.3	124.1	81300*	81300*	37000	30400
40	73.3	121.4	57700	55200	25500	20400
50	68.2	117.8	42100	39700	18900	14800
60	63.0	113.1	32700	30500	14600	11200
70	57.4	107.1	26400	24400	11600	8700
80	51.5	99.7	21900	20100	9400	6900
90	45.0	90.5	18500	16900	7700	5400
100	37.6	78.8	15900	14400	6400	4300
110	28.7	63.0	13800	12400	5300	3400
120	15.4	37.1	11800*	10800	4400	2700
130 Ft. Boom						
30	79.2	134.4	77600*	77600*	36700	30100
40	74.7	131.9	57500	54900	25200	20200
50	70.0	128.5	41900	39400	18600	14500
60	65.2	124.3	32400	30200	14400	10900
70	60.2	118.9	26100	24200	11400	8400
80	54.9	112.4	21600	19900	9200	6600
90	49.3	104.4	18200	16600	7500	5200
100	43.1	94.5	15600	14100	6100	4000
110	36.1	82.0	13500	12100	5000	3100
120	27.5	65.4	11800	10500	4100	2400
130	14.8	38.4	10100*	9200	3300	2000
140 Ft. Boom						
30	80.0	144.5	72500*	72500*	36400	29900
40	75.8	142.3	57300	54700	24900	19900
50	71.5	139.2	41600	39200	18400	14300
60	67.1	135.3	32200	30000	14100	10700
70	62.5	130.4	25900	23900	11100	8200
80	57.8	124.5	21400	19600	8900	6300
90	52.8	117.4	18000	16400	7200	4900
100	47.4	108.8	15300	13900	5800	3800
110	41.4	98.3	13200	11900	4700	2900
120	34.7	85.2	11500	10300	3800	2100
130	26.4	67.7	10100	8900	3100	2000
140	14.2	39.6	8500*	7800	2400	1500
150 Ft. Boom						
35	78.7	153.7	63900*	63900*	29500	23800
40	76.7	152.6	57000	54500	24700	19600
50	72.8	149.7	41400	39000	18100	14000
60	68.7	146.1	31900	29800	13800	10400
70	64.5	141.6	25600	23700	10800	7900
80	60.2	136.2	21100	19400	8600	6000
90	55.6	129.8	17700	16100	6900	4600
100	50.8	122.1	15100	13600	5600	3500
110	45.6	113.0	13000	11600	4500	2600
120	39.9	101.9	11200	10000	3600	2000
130	33.4	88.1	9800	8700	2800	1600
140	25.5	69.9	8600	7500	2100	1200
150	13.7	40.7	7100*	6500	1500	800

Offset Boom Peak

Load In Pounds

Boom Radius Feet	Boom Angle Degrees	Boom Peak Height Feet	With Outriggers		Without Outriggers	
			Over Rear	Over Side	Over Rear	Over Side
160 Ft. Boom						
35	79.4	163.9	58900 *	58900 *	29200	23500
40	77.6	162.9	56400 *	54300	24400	19400
50	73.9	160.2	41100	38700	17800	13700
60	70.1	156.8	31700	29500	13500	10100
70	66.2	152.7	25400	23400	10600	7600
80	62.2	147.7	20900	19100	8300	5800
90	58.1	141.8	17500	15900	6600	4400
100	53.7	134.9	14800	13400	5300	3200
110	49.1	126.7	12700	11400	4200	2300
120	44.1	117.0	11000	9700	3300	
130	38.6	105.4	9500	8400	2500	
140	32.3	91.0	8300	7200		
150	24.7	72.1	7300	6300		
160	13.2	41.8	5900 *	5400		
170 Ft. Boom						
35	80.1	174.1	55400 *	55400 *	29000	23300
40	78.3	173.1	53000 *	53000 *	24100	19100
50	74.9	170.6	40900	38500	17500	13500
60	71.3	167.5	31500	29300	13300	9900
70	67.7	163.6	25100	23200	10300	7400
80	64.0	159.0	20600	18900	8100	5500
90	60.2	153.6	17200	15600	6400	4100
100	56.2	147.2	14600	13100	5000	3000
110	52.0	139.8	12500	11100	3900	2100
120	47.5	131.1	10700	9500	3000	
130	42.7	120.9	9300	8100	2300	
140	37.4	108.8	8100	7000		
150	31.3	93.8	7000	6000		
160	23.9	74.2	6100	5200		
180 Ft. Boom						
40	79.0	183.3	44000 *	44000 *	23800	18800
50	75.7	181.0	37600 *	37600 *	17300	13200
60	72.4	178.0	31200	29000	13000	9600
70	69.0	174.4	24900	22900	10000	7100
80	65.5	170.1	20400	18600	7800	5200
90	62.0	165.0	17000	15400	6100	3800
100	58.3	159.2	14300	12900	4800	2700
110	54.4	152.4	12200	10900	3700	
120	50.4	144.5	10500	9200	2800	
130	46.1	135.4	9000	7900	2000	
140	41.4	124.7	7800	6700		
150	36.3	112.1	6700	5700		
160	30.4	96.5	5800	4900		
180	12.4	44.0	4300	3500		
190 Ft. Boom						
40	79.6	193.5	41200 *	41200 *	23600	18500
50	76.5	191.3	35000 *	35000 *	17000	12900
60	73.4	188.5	30200 *	28800	12700	9300
70	70.2	185.1	24600	22700	9700	6800
80	66.9	181.1	20100	18400	7500	5000
90	63.6	176.3	16700	15100	5800	3500
100	60.1	170.9	14100	12600	4500	2400
110	56.6	164.6	11900	10600	3400	
120	52.9	157.4	10200	9000	2500	
130	48.9	149.1	8800	7600		
140	44.8	139.5	7500	6500		
150	40.3	128.4	6500	5500		
160	35.3	115.2	5600	4600		
180	22.6	78.2	4100	3200		

Boom Radius Feet	Boom Angle Degrees	Boom Peak Height Feet	With Outriggers		Without Outriggers	
			Over Rear	Over Side	Over Rear	Over Side
200 Ft. Boom						
40	80.1	203.7	38400 *	38400 *	23300	18300
50	77.2	201.6	32600 *	32600 *	16700	12700
60	74.2	199.0	28000 *	28000 *	12400	9100
70	71.2	195.7	24200 *	22400	9500	6500
80	68.1	191.9	19800	18100	7300	4700
90	65.0	187.5	16400	14900	5600	3300
100	61.8	182.4	13800	12400	4200	2200
110	58.5	176.5	11700	10400	3100	
120	55.0	169.8	9900	8700	2200	
130	51.4	162.2	8500	7400		
140	47.6	153.5	7300	6200		
150	43.6	143.5	6200	5200		
160	39.2	132.0	5300	4400		
180	28.8	101.7	3800	3000		
200	11.8	46.0	2600			
210 Ft. Boom						
45	79.2	212.9	32800 *	32800 *	19300	14900
50	77.8	211.9	30200 *	30200 *	16400	12400
60	75.0	209.4	25800 *	25800 *	12200	8800
70	72.1	206.3	22200 *	22200 *	9200	6300
80	69.2	202.7	19300 *	17900	7000	4400
90	66.3	198.5	16200	14600	5300	3000
100	63.2	193.7	13500	12100	3900	
110	60.1	188.2	11400	10100	2800	
120	56.9	182.0	9700	8500		
130	53.6	174.9	8200	7100		
140	50.1	166.9	7000	5900		
150	46.4	157.8	6000	5000		
160	42.5	147.4	5000	4100		
180	33.5	121.3	3500	2700		
200	21.4	82.0	2400			
220 Ft. Boom						
45	79.7	223.1	30000 *	30000 *	19100	14600
50	78.4	222.1	27900 *	27900 *	16200	12100
60	75.7	219.7	23700 *	23700 *	11900	8500
70	73.0	216.8	20300 *	20300 *	8900	6000
80	70.2	213.4	17700 *	17600	6700	4200
90	67.4	209.4	15600 *	14400	5000	2700
100	64.6	204.9	13300 *	11800	3700	
110	61.6	199.7	11200	9800	2600	
120	58.6	193.8	9400	8200		
130	55.5	187.2	8000	6800		
140	52.2	179.8	6700	5700		
150	48.8	171.4	5700	4700		
160	45.3	162.0	4800	3800		
180	37.3	138.8	3300	2400		
200	27.4	106.6	2100			
Load Ratings Below Include Jib						
230 Ft. Boom						
45	80.1	233.3	30000 *	30000 *	18800	14300
50	78.9	232.3	25700 *	25700 *	15900	11900
60	76.3	230.0	21700 *	21700 *	11600	8200
70	73.7	227.3	18600 *	18600 *	8600	5700
80	71.1	224.0	16200 *	16200 *	6400	3900
90	68.5	220.3	14200 *	14100	4700	2500
100	65.7	215.9	12500 *	11600	3400	
110	63.0	211.0	10600 *	9600	2300	
120	60.1	205.5	9200	7900		
130	57.2	199.3	7700	6600		
140	54.2	192.4	6500	5400		
150	51.0	184.6	5400	4400		
160	47.7	175.9	4500	3600		
180	40.5	154.9	3000	2200		

(Continued on next page)

MC-7125

Offset Boom Peak

Maximum Rated Load In Pounds

Boom Radius Feet	Boom Angle Degrees	Boom Peak Height Feet	With Outriggers		Without Outriggers	
			Over Rear	Over Side	Over Rear	Over Side
240 Ft. Boom						
50	79.3	242.5	21300*	21300*	15600	11600
60	76.9	240.3	18800*	18800*	11400	8000
70	74.4	237.7	17000*	17000*	8400	5500
80	71.9	234.6	14900*	14900*	6200	3600
90	69.4	231.0	12900*	12900*	4500	2200
100	66.8	226.9	11200*	11200*	3100	
110	64.2	222.2	9400*	9300*	2000	
120	61.5	217.0	8200*	7700*		
130	58.7	211.2	7100*	6300*		
140	55.9	204.6	6100*	5200*		
150	52.9	197.4	5000*	4200*		
160	49.8	189.2	4200*	3300*		
250 Ft. Boom						
50	79.8	252.7	18500*	18500*	15300	11300
60	77.4	250.6	16400*	16400*	11100	7700
70	75.1	248.1	14800*	14800*	8100	5200
80	72.7	245.1	13400*	13400*	5900	3300
90	70.3	241.7	11700*	11700*	4200	
100	67.8	237.8	10100*	10100*	2800	
110	65.3	233.3	8600*	8600*		
120	62.7	228.4	7100*	7100*		
130	60.1	222.8	6100*	6100*		
140	57.4	216.7	5100*	4900*		
150	54.6	209.8	4200*	3900*		
160	51.8	202.2	3300*	3100*		
260 Ft. Boom						
50	80.2	262.9	16100*	16100*	15100	11000
60	77.9	260.9	14400*	14400*	10800	7400
70	75.7	258.4	13000*	13000*	7800	4900
80	73.4	255.6	11600*	11600*	5600	3100
90	71.0	252.3	10500*	10500*	3900	
100	68.7	248.6	8900*	8900*	2600	
110	66.3	244.3	7500*	7500*		
120	63.9	239.6	6100*	6100*		
130	61.4	234.3	5100*	5100*		
140	58.8	228.5	4200*	4200*		
150	56.2	222.0	3300*	3300*		
270 Ft. Boom						
55	79.5	272.1	13400*	13400*	12500	8800
60	78.4	271.1	12600*	12600*	10500	7200
70	76.2	268.8	10000*	10000*	7600	4700
80	74.0	266.0	10000*	10000*	5300	2800
90	71.8	262.9	9000*	9000*	3700	
100	69.5	259.3	7800*	7800*	2300	
110	67.2	255.3	6500*	6500*		
120	64.9	250.7	5300*	5300*		
130	62.5	245.7	4200*	4200*		
140	60.1	240.2	3300*	3300*		
280 Ft. Boom						
55	79.8	282.3	12000*	12000*	12000	8500
60	78.8	281.3	11100*	11100*	10300	6900
70	76.7	279.1	8000*	8000*	7300	4400
80	74.6	276.4	8000*	8000*	5100	2500
90	72.4	273.4	7700*	7700*	3400	
100	70.3	270.0	6700*	6700*	2000	
110	68.1	266.1	5500*	5500*		
120	65.9	261.8	4400*	4400*		
130	63.6	257.0	3300*	3300*		

- Boom 180 ft. and over requires mast in addition to raised gantry. Mast with raised gantry may also be used with boom lengths under 180 ft.
- More than one part hoist line must be used on any boom when lifting radius is less than 20 ft.
- Intermediate suspension required for booms 220 ft. and over.
- Maximum length of boom (without jib).....220 ft.
- With gantry in raised position (21 ft. 9 1/2 in. overall height), the following maximum lengths may be carried * over rear in low-low gear without outriggers:
 170 ft. boom without jib 140 ft. boom and 50 ft. jib
 150 ft. boom and 30 ft. jib 130 ft. boom and 60 ft. jib
 *For straight back and forward movement, remove 10 ft. of boom from that specified for conditions which require maneuverability.
- With gantry in lowered position or gantry lowered and mast pinned to the base section (12 ft. 11 1/2 in. overall height less jib) (17 ft. 5 in. with jib), the following maximum boom lengths may be carried over the rear without outriggers:
 110 ft. boom without jib 70 ft. boom and 60 ft. jib
 80 ft. boom and 30 ft. jib
- With outriggers set and mast and gantry in raised position, the following maximum boom lengths may be raised unassisted, from the horizontal over the rear:
 220 ft. boom without jib 200 ft. boom plus 60 ft. jib
 210 ft. boom plus 40 ft. jib
- For boom and jib combinations longer than shown in Note 17, and up to 220 ft. boom and 60 ft. jib rear auxiliary outriggers are required.
- When working with boom lengths that require auxiliary outriggers for erection, do not exceed the radii as shown on crane load rating chart.
- The rear hinged auxiliary outrigger beams are to be used only when raising or lowering long booms. They are never to be used or placed under load during hoisting operations.

21. Hoist Cable Reeving:

Number of Parts of Hoist Lines	1	2	3	4	5	6	7	8	9	10	11	12
Maximum Loads (Lbs.)	22000	44000	66000	88000	110000	132000	154000	176000	198000	220000	242000	250000

Use 3/4" dia. hoist cable (6 x 25, IWRC) of 39.8 tons breaking strength

- Crane load ratings are based on the use of 1 3/8" dia. swaged pendants (6 x 25, IWRC) of 96 tons breaking strength and 16 parts of 5/8" dia. derricking cable (6 x 30G, IWRC) of 19.6 tons breaking strength.

NOTES FOR JIB APPLICATION

- Jibs may be used straight or offset. 30 ft. jib is of two-piece design and may be extended to 60 ft. with center sections. The following data apply:

Jib Lgh.	Radius	Max. Lgh. of Boom Incl. Jib	Jib Offsets and Maximum Load Rating (Lbs.)				Weight of Jib and Backstays	
			0 Ft.	6 Ft.	12 Ft.	18 Ft. 24 Ft.		
30 Ft.	Up thru 60' Over 60'	250 Ft.	30000 20000	25000 17000	22000 15000		1920 Lbs.	
40 Ft.	Up thru 60' Over 60'	260 Ft.	21000 14000	18000 12000	16000 11000	10000 8000	2320 Lbs.	
50 Ft.	Up thru 60' Over 60'	270 Ft.	15000 10000	13000 9000	12000 8000	9000 7000	8000 6000	2570 Lbs.
60 Ft.	Up thru 60' Over 60'	280 Ft.	12000 8000	11000 7500	10000 7000	8000 6000	7000 5000	2770 Lbs.

- Load ratings for jibs are the same as for the boom length which is equal to the length of main boom plus jib but in no case may they exceed the capacities shown above.
- With jib installed, load ratings over main boom head must be reduced as follows:

2020 lbs. for 30 ft. jib 2970 lbs. for 50 ft. jib
 2630 lbs. for 40 ft. jib 3220 lbs. for 60 ft. jib

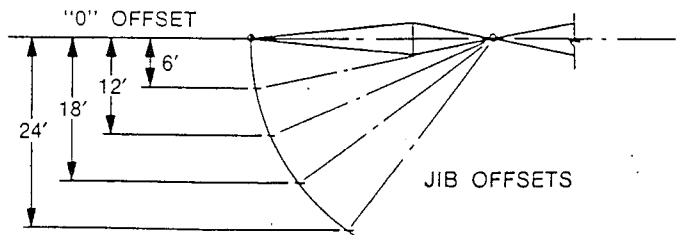

MC-7125

Long Tapered Boom Peak

RADIUS DIAGRAM:

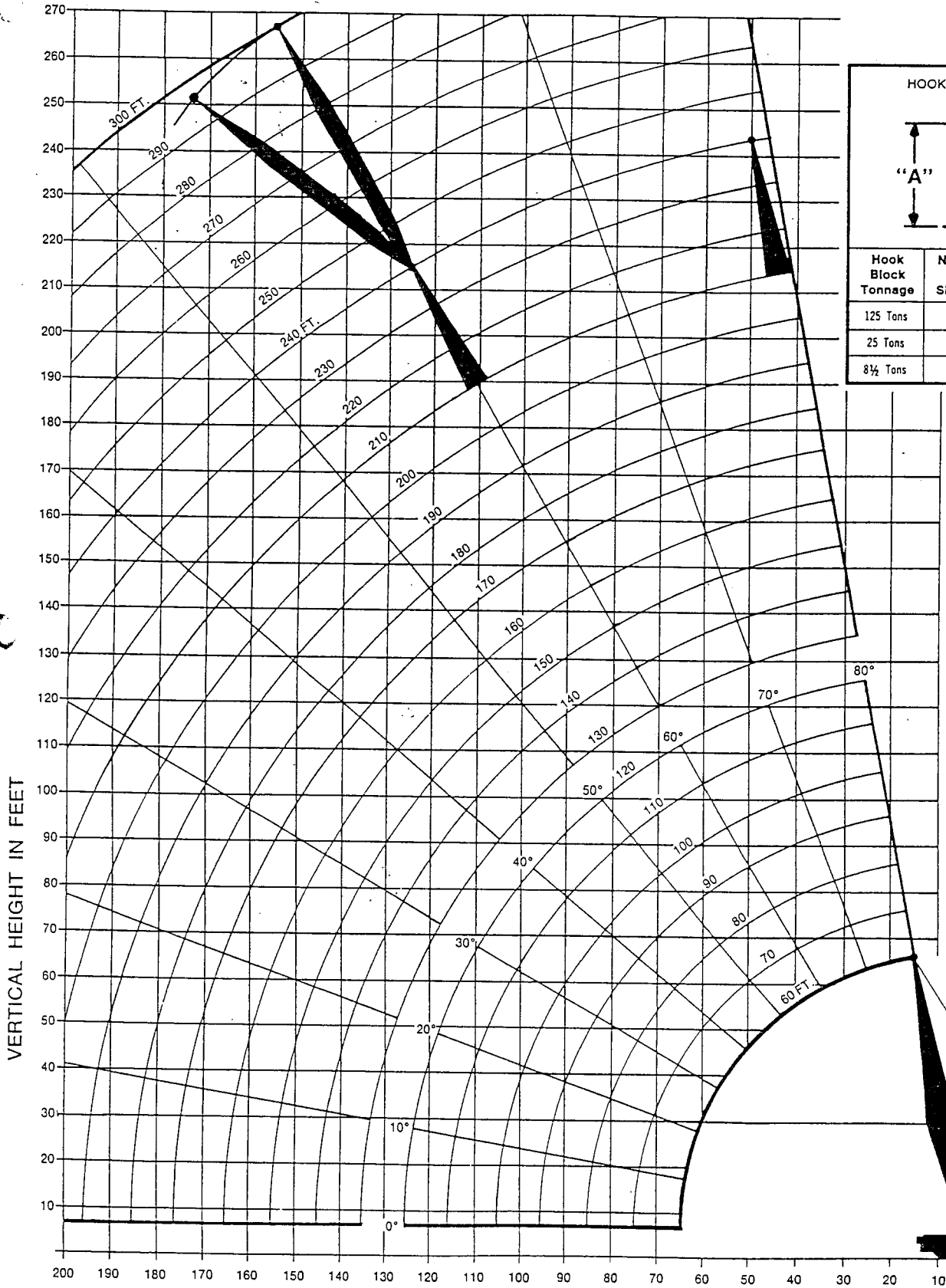

HOOK BLOCK CLEARANCES

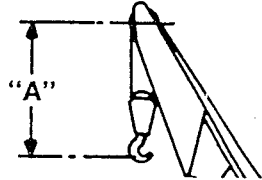

Hook Block Tonnage	Number of Sheaves	Hook Block Weight	Dimension "A"
125 Tons	6	2450 Lbs.	18'-0"
25 Tons	1	1145 Lbs.	7'-10"
8½ Tons	None	615 Lbs.	4'-6"

**LONG TAPERED
PEAK BOOM**

**MC-7125
10 X 4**

SIMS CRANE & EQUIPMENT CO.
5002 E. HILLSBOROUGH AVE.
TAMPA FL. 33610
(813) 626-8102

RADIUS IN FEET

MC-7125

Load Ratings With

CAPACITY CHART:

Maximum Rate

Boom Radius Feet	Boom Angle Degrees	Boom Peak Height Feet	With Outriggers		Without Outriggers	
			Over Rear	Over Side	Over Rear	Over Side
60 Ft. Boom						
15	79.3	66.0	182900*	182900*	92600	81500
20	74.4	64.8	149600*	149600*	64000	54800
25	69.3	63.1	120500*	120500*	48600	40800
30	64.1	61.0	90800	89000	38900	32300
40	52.9	54.9	59900	57300	27400	22400
50	39.7	45.3	44300	41800	20800	16800
60	20.6	28.1	32000*	32000*	16600	13200
70 Ft. Boom						
20	76.6	75.1	149300*	149300*	63800	54500
25	72.4	73.7	120100*	120100*	48300	40600
30	68.0	71.9	90600	88800	38600	32100
40	58.9	66.9	59700	57100	27200	22200
50	48.7	59.6	44100	41600	20600	16600
60	36.6	48.8	34700	32400	16400	13000
70	19.0	29.8	26600*	26400	13400	10500
80 Ft. Boom						
20	78.3	85.3	145000*	145000*	63500	54300
25	74.7	84.1	119800*	119800*	48100	40400
30	70.9	82.6	90400	88600	38400	31900
40	63.1	78.4	59500	56900	26900	21900
50	54.8	72.3	43800	41400	20400	16300
60	45.4	64.0	34400	32200	16100	12700
70	34.2	52.0	28100	26100	13200	10200
80	17.8	31.5	22500*	21800	11000	8400
90 Ft. Boom						
20	79.6	95.5	136100*	136100*	63300	54100
25	76.4	94.5	119500*	119500*	47800	40200
30	73.1	93.1	90200	88500	38200	31600
40	66.3	89.4	59200	56600	26700	21700
50	59.1	84.3	43600	41100	20200	16100
60	51.4	77.3	34200	32000	15900	12500
70	42.7	68.0	27900	25900	12900	10000
80	32.2	54.9	23400	21600	10700	8200
90	16.8	33.0	19200*	18400	9000	6800
100 Ft. Boom						
25	77.8	104.7	117800*	117800*	47600	39900
30	74.8	103.5	90000	88300	37900	31400
40	68.8	100.2	59000	56400	26500	21500
50	62.5	95.7	43400	40900	19900	15900
60	55.8	89.7	33900	31700	15700	12300
70	48.6	82.0	27600	25700	12700	9800
80	40.4	71.8	23100	21400	10500	8000
90	30.5	57.7	19700	18100	8800	6500
100	15.9	34.4	16500*	15600	7500	5400
110 Ft. Boom						
25	78.9	114.9	110300*	110300*	47400	39700
30	76.2	113.8	89800	88100	37700	31200
40	70.8	110.9	58800	56200	26200	21300
50	65.2	106.8	43100	40700	19700	15700
60	59.3	101.6	33700	31500	15400	12100
70	53.0	94.9	27400	25400	12500	9600
80	46.2	86.4	22900	21100	10300	7700
90	38.4	75.4	19500	17900	8600	6300
100	29.0	60.4	16800	15400	7200	5200
110	15.2	35.8	14200*	13400	6200	4300
120 Ft. Boom						
30	77.4	124.1	89600	88000	37500	31000
40	72.5	121.4	58600	56000	26000	21000
50	67.4	117.8	42900	40500	19500	15400
60	62.1	113.0	33400	31300	15200	11800
70	56.5	107.1	27100	25200	12200	9300
80	50.6	99.7	22600	20900	10000	7500
90	44.1	90.5	19200	17600	8400	6100
100	36.7	78.8	16600	15100	7000	5000
110	27.8	62.9	14500	13100	5900	4100
120	14.5	37.1	12200*	11500	5000	3300

Boom Radius Feet	Boom Angle Degrees	Boom Peak Height Feet	With Outriggers		Without Outriggers	
			Over Rear	Over Side	Over Rear	Over Side
130 Ft. Boom						
30	78.4	134.3	89500	87800	37200	30700
40	73.8	131.9	58300	55800	25800	20800
50	69.2	128.5	42700	40200	19200	15200
60	64.4	124.2	33200	31000	15000	11600
70	59.4	118.9	26900	24900	12000	9100
80	54.1	112.3	22400	20600	9800	7200
90	48.5	104.3	19000	17400	8100	5800
100	42.3	94.5	16300	14900	6800	4700
110	35.2	82.0	14200	12900	5700	3800
120	26.7	65.3	12500	11200	4800	3000
130	13.9	38.3	10500*	9900	4000	2400
140 Ft. Boom						
30	79.2	144.5	84800*	84800*	37000	30500
40	75.0	142.2	58100	55600	25500	20500
50	70.7	139.2	42400	40000	19000	14900
60	66.3	135.2	33000	30800	14700	11300
70	61.8	130.4	26600	24700	11700	8800
80	57.0	124.5	22100	20400	9500	7000
90	52.0	117.3	18700	17100	7800	5500
100	46.6	108.7	16100	14600	6500	4400
110	40.7	98.3	13900	12600	5400	3500
120	33.9	85.1	12200	11000	4500	2800
130	25.7	67.7	10800	9600	3700	2100
140	13.4	39.5	9000*	8500	3100	
150 Ft. Boom						
35	78.0	153.7	70400	68100	30100	24400
40	76.0	152.6	57900	55400	25300	20300
50	72.1	149.7	42200	39800	18700	14700
60	68.0	146.1	32700	30600	14400	11000
70	63.8	141.6	26400	24400	11500	8500
80	59.5	136.2	21800	20100	9200	6700
90	54.9	129.8	18400	16900	7600	5300
100	50.1	122.1	15800	14400	6200	4100
110	44.9	113.0	13700	12400	5100	3200
120	39.2	101.9	11900	10700	4200	2500
130	32.7	88.1	10500	9400	3400	
140	24.8	69.9	9300	8200	2800	
150	13.0	40.7	7600*	7200	2200	
160 Ft. Boom						
35	78.8	163.9	69300*	67900	29800	24200
40	76.9	162.9	57700	55200	25000	20000
50	73.2	160.2	41900	39600	18400	14400
60	69.4	156.8	32500	30300	14200	10800
70	65.6	152.7	26100	24200	11200	8300
80	61.6	147.7	21600	19900	9000	6400
90	57.4	141.8	18200	16600	7300	5000
100	53.1	134.9	15500	14100	5900	3900
110	48.4	126.7	13400	12100	4800	3000
120	43.4	117.0	11700	10500	3900	2200
130	37.9	105.4	10200	9100	3200	
140	31.7	91.0	9000	7900	2500	
150	24.0	72.1	7900	7000		
160	12.6	41.8	6400*	6100		
170 Ft. Boom						
35	79.4	174.1	64900*	64900*	29600	23900
40	77.7	173.1	57400	55000	24700	19700
50	74.2	170.6	41700	39300	18100	14100
60	70.7	167.5	32200	30100	13900	10500
70	67.1	163.6	25900	24000	10900	8000
80	63.4	159.0	21300	19600	8700	6100
90	59.5	153.5	17900	16400	7000	4700
100	55.5	147.2	15300	13800	5600	3600
110	51.4	139.8	13200	11800	4500	2700
120	46.9	131.1	11400	10200	3600	
130	42.1	120.9	10000	8800	2900	
140	36.8	108.8	8700	7700	2200	
150	30.7	93.8	7700	6700		
160	23.3	74.2	6800	5800		

Long Tapered Boom Peak

Load In Pounds

Boom Radius Feet	Boom Angle Degrees	Boom Peak Height Feet	With Outriggers		Without Outriggers	
			Over Rear	Over Side	Over Rear	Over Side
180 Ft. Boom						
40	78.4	183.3	56600*	54800	24400	19400
50	75.1	181.0	41500	39100	17900	13800
60	71.8	178.0	32000	29800	13600	10200
70	68.4	174.4	25600	23700	10600	7700
80	65.0	170.1	21100	19400	8400	5900
90	61.4	165.0	17700	16100	6700	4400
100	57.7	159.2	15000	13600	5400	3300
110	53.9	152.4	12900	11600	4300	2400
120	49.8	144.5	11100	9900	3400	
130	45.5	135.4	9700	8600	2600	
140	40.8	124.7	8500	7400		
150	35.7	112.0	7400	6400		
160	29.8	96.5	6500	5600		
180	11.8	43.9	5000	4200		
190 Ft. Boom						
40	79.0	193.5	52700*	52700*	24200	19200
50	75.9	191.3	41200	38900	17600	13500
60	72.8	188.5	31700	29600	13300	9900
70	69.6	185.1	25400	23500	10300	7400
80	66.4	181.1	20800	19100	8100	5600
90	63.0	176.3	17400	15900	6400	4200
100	59.6	170.9	14800	13300	5100	3000
110	56.0	164.6	12600	11300	4000	2100
120	52.3	157.3	10900	9700	3100	
130	48.4	149.1	9400	8300	2300	
140	44.2	139.5	8200	7200		
150	39.7	128.4	7100	6200		
160	34.7	115.2	6200	5300		
180	22.0	78.2	4700	3900		
200 Ft. Boom						
40	79.6	203.7	49000*	49000*	23900	18900
50	76.7	201.6	41000	38700	17300	13300
60	73.7	199.0	31500	29400	13000	9700
70	70.7	195.7	25100	23200	10000	7100
80	67.6	191.9	20600	18900	7800	5300
90	64.5	187.5	17200	15600	6100	3900
100	61.3	182.4	14500	13100	4800	2800
110	57.9	176.5	12400	11100	3700	
120	54.5	169.8	10600	9400	2800	
130	50.9	162.2	9200	8000	2000	
140	47.1	153.5	7900	6900		
150	43.0	143.5	6900	5900		
160	38.7	131.9	6000	5000		
180	28.3	101.7	4500	3600		
200	11.2	46.0	3300	2500		
210 Ft. Boom						
45	78.7	212.9	40700*	40700*	19900	15500
50	77.3	211.9	38800*	38400	17000	13000
60	74.5	209.3	31200	29100	12800	9400
70	71.6	206.3	24900	23000	9800	6900
80	68.7	202.7	20300	18600	7600	5000
90	65.8	198.5	16900	15400	5900	3600
100	62.7	193.7	14200	12800	4500	2500
110	59.6	188.2	12100	10800	3400	
120	56.4	181.9	10400	9200	2500	
130	53.1	174.9	8900	7800		
140	49.6	166.9	7700	6600		
150	45.9	157.8	6600	5600		
160	42.0	147.4	5700	4800		
180	33.0	121.3	4200	3400		
200	20.9	81.9	3000	2300		

Boom Radius Feet	Boom Angle Degrees	Boom Peak Height Feet	With Outriggers		Without Outriggers	
			Over Rear	Over Side	Over Rear	Over Side
220 Ft. Boom						
45	79.2	223.1	35100*	35100*	19600	15200
50	77.9	222.1	33400*	33400*	16700	12700
60	75.2	219.7	30700*	28900	12500	9100
70	72.5	216.8	24600	22700	9500	6600
80	69.7	213.4	20100	18400	7300	4700
90	66.9	209.4	16600	15100	5600	3300
100	64.1	204.9	14000	12600	4200	2200
110	61.1	199.7	11800	10500	3100	
120	58.1	193.8	10100	8900	2200	
130	55.0	187.2	8600	7500		
140	51.8	179.8	7400	6400		
150	48.4	171.4	6300	5400		
160	44.8	162.0	5400	4500		
180	36.8	138.8	3900	3100		
200	26.9	106.6	2700	2000		
230 Ft. Boom						
45	79.7	233.3	30300*	30300*	19300	14900
50	78.4	232.3	28800*	28800*	16400	12400
60	75.9	230.0	26200*	26200*	12200	8800
70	73.3	227.3	24100*	22500	9200	6300
80	70.7	224.0	19800	18100	7000	4500
90	68.0	220.2	16400	14800	5300	3000
100	65.3	215.9	13700	12300	4000	
110	62.5	211.0	11600	10300	2900	
120	59.7	205.5	9800	8600	2000	
130	56.7	199.3	8400	7300		
140	53.7	192.4	7100	6100		
150	50.5	184.6	6100	5100		
160	47.2	175.9	5200	4200		
180	40.0	154.9	3700	2800		
200	31.5	127.1	2500			
240 Ft. Boom						
50	78.9	242.5	25000*	25000*	16200	12200
60	76.5	240.3	22500*	22500*	11900	8600
70	74.0	237.7	20500*	20500*	8900	6000
80	71.5	234.6	18700*	17900	6700	4200
90	69.0	231.0	16100	14600	5000	2800
100	66.4	226.9	13500	12100	3700	
110	63.7	222.2	11300	10000	2600	
120	61.1	217.0	9600	8400		
130	58.3	211.2	8100	7000		
140	55.4	204.6	6900	5800		
150	52.5	197.4	5800	4800		
160	49.4	189.2	4900	4000		
180	42.8	170.0	3400	2600		
Load Ratings Below Include Jib						
250 Ft. Boom						
50	79.4	252.7	21500*	21500*	15900	11900
60	77.0	250.6	19400*	19400*	11600	8300
70	74.7	248.1	17600*	17600*	8600	5800
80	72.3	245.1	16300*	16300*	6400	3900
90	69.8	241.7	14800*	14300	4700	2500
100	67.4	237.8	12900*	11800	3400	
110	64.9	233.3	11100	9800	2300	
120	62.3	228.4	9300	8100		
130	59.7	222.8	7800	6700		
140	57.0	216.7	6600	5600		
150	54.2	209.8	5500	4600		
160	51.3	202.2	4600	3700		
180	45.2	184.4	3100	2300		

(Continued on next page)

MC-7125 Long Tapered Boom Peak

Maximum Rated Load In Pounds

Boom Radius Foot	Boom Angle Degrees	Boom Peak Height Feet	With Outriggers		Without Outriggers	
			Over Rear	Over Side	Over Rear	Over Side
260 Ft. Boom						
50	79.8	262.9	18600*	18600*	15600	11600
60	77.5	260.9	16700*	16700*	11300	8000
70	75.3	258.4	15200*	15200*	8400	5500
80	73.0	255.6	14000*	14000*	6200	3600
90	70.6	252.3	12900*	12900*	4500	
100	68.3	248.6	11400*	11400*	3100	
110	65.9	244.3	9900*	9500	2000	
120	63.5	239.6	8200*	7900		
130	61.0	234.3	7000*	6500		
140	58.4	228.5	6000*	5300		
150	55.8	222.0	5000*	4300		
160	53.1	214.9	4100*	3500		
270 Ft. Boom						
55	79.1	272.1	15200*	15200*	13000	9300
60	78.0	271.1	14400*	14400*	11100	7700
70	75.8	268.8	13200*	13200*	8100	5200
80	73.6	266.0	12100*	12100*	5900	3400
90	71.4	262.9	11100*	11100*	4200	
100	69.1	259.3	10000*	10000*	2800	
110	66.8	255.2	8500*	8500*		
120	64.5	250.7	7200*	7200*		
130	62.1	245.7	5900*	5900*		
140	59.7	240.1	4900*	4900*		
150	57.2	234.0	3900*	3900*		
160	54.7	227.3	3100*	3100*		
280 Ft. Boom						
55	79.5	282.3	13100*	13100*	12700	9100
60	78.4	281.3	12600*	12600*	10800	7400
70	76.3	279.1	11400*	11400*	7800	4900
80	74.2	276.4	10400*	10400*	5600	3100
90	72.1	273.4	9400*	9400*	3900	
100	69.9	270.0	8500*	8500*	2600	
110	67.7	266.1	7200*	7200*		
120	65.5	261.8	6000*	6000*		
130	63.2	257.0	4700*	4700*		
140	60.9	251.7	3800*	3800*		
290 Ft. Boom						
60	78.8	291.5	10900*	10900*	10500	7200
70	76.8	289.3	9900*	9900*	7500	4700
80	74.8	286.8	8900*	8900*	5300	2800
90	72.7	283.9	8000*	8000*	3600	
100	70.6	280.6	7100*	7100*	2300	
110	68.5	276.9	6000*	6000*		
120	66.4	272.7	4800*	4800*		
130	64.2	268.1	3800*	3800*		
300 Ft. Boom						
60	79.2	301.7	9500*	9500*	9500*	6900
70	77.3	299.6	8000*	8000*	7200	4400
80	75.3	297.2	7600*	7600*	5000	2500
90	73.3	294.4	6800*	6800*	3300	
100	71.3	291.2	5900*	5900*		
110	69.3	287.6	4900*	4900*		
120	67.2	283.6	3800*	3800*		

- Boom 180' and over requires mast in addition to raised gantry. Mast with raised gantry may also be used with boom lengths under 180 ft. Spreader bar required for booms 130 ft. to 170 ft. inclusive, when no mast is used, and for booms 200 ft. and over when a mast is used.
- More than one part hoist line must be used on any boom when lifting radius is less than 20 ft.
- Intermediate suspension required for booms 220 ft. and over.
- Maximum length of boom (without jib).....240 ft.
- With gantry in raised position (21 ft. 9½ in. overall height), the following maximum lengths may be carried* over rear in low-low gear without outriggers:
170 ft. boom without jib
140 ft. boom and 30 ft. jib
130 ft. boom and 60 ft. jib
*For straight back and forward movement, remove 10 ft. of boom from that specified for conditions which require maneuverability.
- With gantry in lowered position or gantry lowered and mast pinned to the base section (12 ft. 11½ in. overall height less jib) (19 ft. 3 in. with jib), the following maximum boom lengths may be carried over the rear without outriggers:
110 ft. boom without jib
80 ft. boom and 30 ft. jib
70 ft. boom and 60 ft. jib
- With outriggers set and mast and gantry in raised position, the following maximum boom lengths may be raised unassisted, from the horizontal over the rear:
240 ft. boom without jib
220 ft. boom and 30 ft. jib
200 ft. boom and 60 ft. jib
- For boom and jib combinations longer than shown in Note 17 and up to 240 ft. boom and 60 ft. jib rear auxiliary outriggers are required.
- When working with boom lengths that require auxiliary outriggers for erection, do not exceed the radii as shown on crane load rating chart.
- The rear hinged auxiliary outrigger beams are to be used only when raising or lowering long booms. They are never to be used or placed under load during hoisting operations.
- Hoist Cable Reeving:

Number of Parts of Hoist Lines	1	2	3	4	5	6	7	8	9
Maximum Loads (Lbs.)	22000	44000	66000	88000	110000	132000	154000	176000	182900

Use ¾" dia. hoist cable (6 x 25, IWRC) of 39.8 tons breaking strength.

- Crane load ratings are based on the use of 1¾" dia. swaged pendants (6 x 25, IWRC) of 96 tons breaking strength and 16 parts of ½" dia. derricking cable (6 x 30G, IWRC) of 19.6 tons breaking strength.

NOTES FOR JIB APPLICATION

- Jibs may be used straight or offset. 30 ft. jib is of two-piece design and may be extended to 60 ft. with center sections. The following data apply:

Jib Lgth.	Radius	Max. Lgth. of Boom Incl. Jib	Jib Offset and Max. Load Rating (Lbs.)				Weight of Jib and Backstays
			0 Ft.	6 Ft.	12 Ft.	18 Ft.	
30 Ft.	Up thru 60' Over 60'	270 Ft.	30000 20000	25000 17000	22000 15000		1920 Lbs.
40 Ft.	Up thru 60' Over 60'	280 Ft.	21000 14000	18000 12000	16000 11000	10000 8000	2320 Lbs.
50 Ft.	Up thru 60' Over 60'	290 Ft.	15000 10000	13000 9000	12000 8000	9000 7000	2570 Lbs.
60 Ft.	Up thru 60' Over 60'	300 Ft.	12000 8000	11000 7500	10000 7000	8000 6000	2770 Lbs.

- Load ratings for jibs are the same as for the boom length which is equal to the length of main boom plus jib but in no case may they exceed the capacities shown above.
- With jib installed, load ratings over main boom head must be reduced as follows:

2020 lbs. for 30 ft. jib 2970 lbs. for 50 ft. jib
2630 lbs. for 40 ft. jib 3220 lbs. for 60 ft. jib

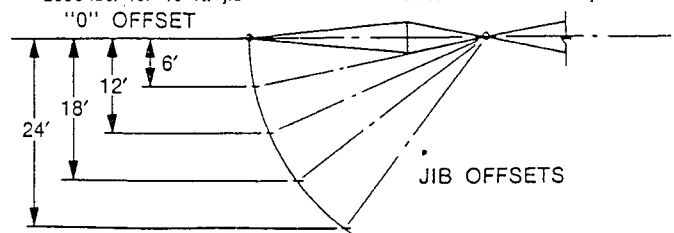

Hammer-Head Boom Peak

RADIUS DIAGRAM:

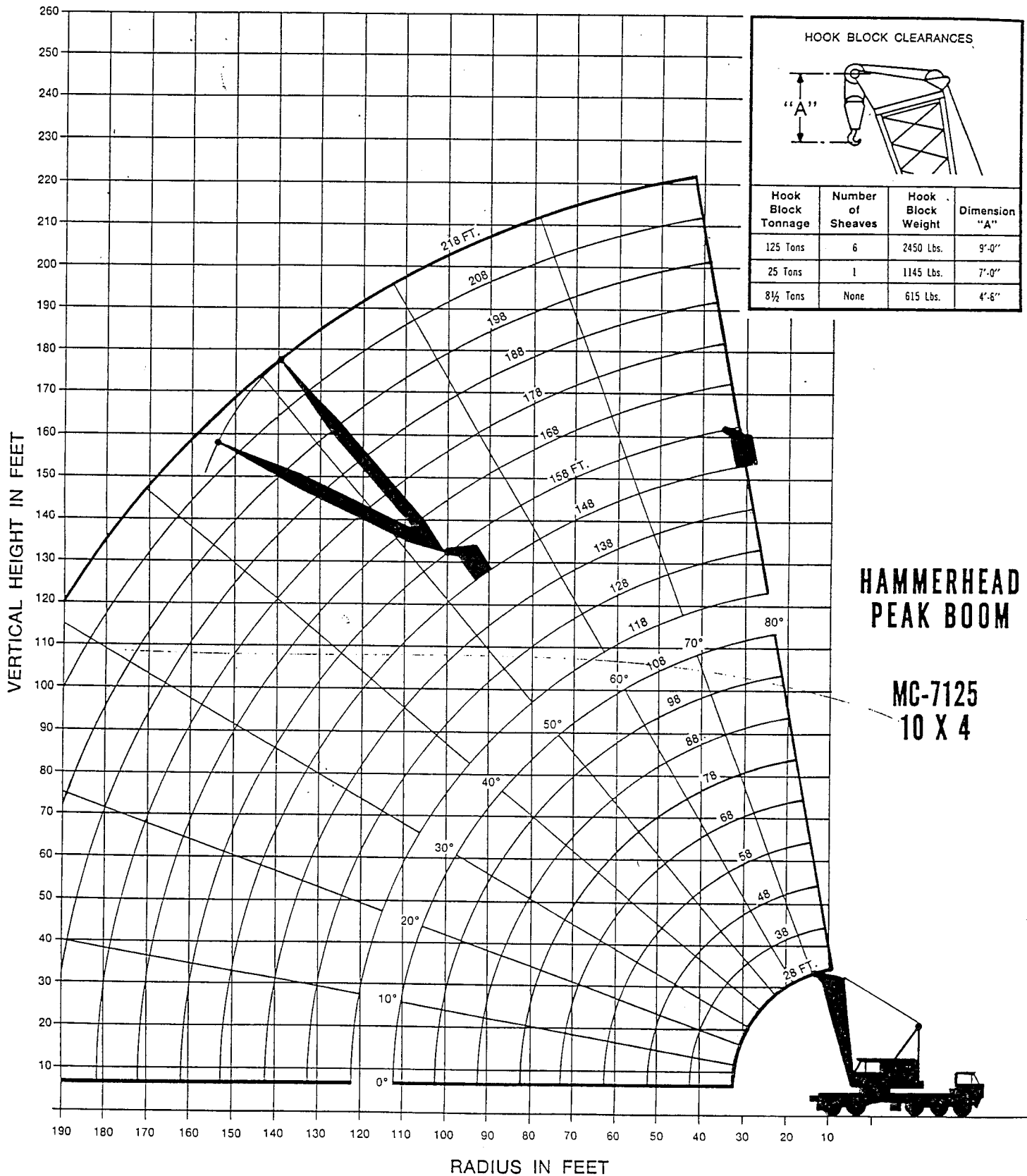

MC-7125

Load Ratings With

CAPACITY CHART:

Maximum Rate

Boom Radius Feet	Boom Angle Degrees	Boom Peak Height Feet	With Outriggers		Without Outriggers	
			Over Rear	Over Side	Over Rear	Over Side
28 Ft. Boom						
12	79.6	34.0	250000*	250000*	125500	113900
15	73.1	32.9	195700*	195700*	92600	81400
20	61.4	30.1	138500*	138500*	64000	54700
25	47.7	25.6	92500*	92500*	48500	40800
30	28.2	17.4	57300*	57300*	38800	32200
38 Ft. Boom						
12	82.4	44.2	188900*	188900*	125400	113800
15	77.7	43.5	177200*	177200*	92500	81300
20	69.7	41.5	149700*	149700*	63900	54600
25	61.0	38.7	115900*	115900*	48400	40600
30	51.4	34.7	86500	86500	38700	32100
40	23.2	19.1	43400*	43400*	27200	22200
48 Ft. Boom						
15	80.3	53.8	162600*	162600*	92400	81200
20	74.1	52.3	147200*	147200*	63700	54400
25	67.7	50.2	120200	120200	48300	40500
30	60.8	47.4	90200	88300	38600	32000
40	45.0	38.7	59300	56600	27100	22100
50	20.1	20.5	34400*	34400*	20500	16500
58 Ft. Boom						
15	82.0	64.0	150700*	150700*	92200	81100
20	77.0	62.8	136300*	136300*	63600	54300
25	71.8	61.1	120000	120000	48100	40400
30	66.3	58.9	90000	88100	38400	31800
40	54.6	52.5	59100	56400	27000	21900
50	40.5	42.2	43500	41000	20400	16300
60	17.9	21.8	28200*	28200*	16200	12700
68 Ft. Boom						
20	78.9	73.1	127000*	127000*	63400	54200
25	74.5	71.7	116100*	116100*	48000	40300
30	70.1	69.8	89700	87900	38300	31700
40	60.6	64.7	58800	56200	26800	21700
50	50.0	57.0	43300	40800	20200	16100
60	37.1	45.5	33900	31600	16000	12500
70	16.2	23.0	23600*	23600*	13000	10000
78 Ft. Boom						
20	80.4	83.4	118900*	118900*	63300	54000
25	76.6	82.1	108700*	108700*	47800	40000
30	72.7	80.5	89500	87700	38100	31400
40	64.7	76.2	58600	56000	26500	21500
50	56.1	69.9	43000	40500	20000	15900
60	46.3	61.2	33600	31400	15700	12300
70	34.4	48.4	27400	25400	12700	9700
80	15.0	24.1	20000*	20000*	10500	7900
88 Ft. Boom						
20	81.5	93.6	111600*	111600*	63100	53700
25	78.1	92.5	102000*	102000*	47500	39700
30	74.8	91.1	89300	87500	37800	31200
40	67.8	87.3	58400	55800	26300	21200
50	60.4	82.0	42800	40300	19700	15600
60	52.4	74.8	33400	31200	15400	12000
70	43.3	65.1	27100	25100	12400	9500
80	32.2	51.2	22600	20800	10200	7600
90	13.9	25.1	17200*	17200*	8500	6200

Boom Radius Feet	Boom Angle Degrees	Boom Peak Height Feet	With Outriggers		Without Outriggers	
			Over Rear	Over Side	Over Rear	Over Side
98 Ft. Boom						
25	79.4	102.7	95900*	95900*	47200	39500
30	76.4	101.5	88400*	87300	37500	30900
40	70.2	98.1	58200	55600	26000	20900
50	63.8	93.5	42500	40100	19400	15300
60	56.9	87.4	33100	30900	15100	11700
70	49.4	79.4	26800	24900	12100	9200
80	40.9	68.7	22300	20600	9900	7300
90	30.3	53.8	19000	17300	8200	5900
100	13.1	26.1	14900*	14900*	6900	4800
108 Ft. Boom						
25	80.4	113.0	90400*	90400*	47000	39200
30	77.7	111.8	83300*	83300*	37200	30600
40	72.1	108.8	57900	55300	25700	20700
50	66.4	104.7	42300	39800	19100	15000
60	60.4	99.3	32900	30700	14900	11400
70	53.9	92.4	26600	24600	11900	8900
80	46.9	83.6	22100	20300	9700	7100
90	38.8	72.2	18700	17100	8000	5700
100	28.8	56.2	16100	14600	6600	4500
110	12.4	27.0	12900*	12600	5500	3600
118 Ft. Boom						
30	78.7	122.1	78500*	78500*	36900	30300
40	73.7	119.4	57700	55100	25400	20400
50	68.5	115.6	42100	39600	18800	14800
60	63.1	110.8	32600	30400	14600	11200
70	57.4	104.8	26300	24400	11600	8700
80	51.4	97.2	21800	20100	9400	6800
90	44.7	87.7	18400	16800	7700	5400
100	37.0	75.4	15800	14300	6300	4300
110	27.5	58.6	13700	12400	5200	3400
120	11.8	27.9	11100*	10700	4300	2600
128 Ft. Boom						
30	79.6	132.3	74100*	74100*	36700	30100
40	75.0	129.8	57500	54900	25200	20100
50	70.3	126.4	41800	39400	18600	14500
60	65.4	122.1	32400	30200	14300	10900
70	60.3	116.6	26100	24100	11300	8400
80	54.9	109.9	21600	19800	9100	6500
90	49.1	101.7	18200	16600	7400	5100
100	42.7	91.5	15600	14100	6100	4000
110	35.4	78.6	13400	12100	5000	3100
120	26.3	60.8	11700	10500	4100	2300
130	11.2	28.8	9400*	9100	3300	
138 Ft. Boom						
30	80.4	142.5	69900*	69900*	36400	29800
40	76.1	140.2	57200	54700	24900	19800
50	71.8	137.1	41600	39100	18300	14200
60	67.3	133.1	32100	30000	14000	10600
70	62.7	128.1	25800	23900	11000	8100
80	57.8	122.1	21300	19600	8800	6300
90	52.7	114.8	17900	16300	7100	4800
100	47.2	106.0	15300	13800	5800	3700
110	41.0	95.2	13200	11800	4700	2800
120	34.0	81.6	11500	10200	3800	2100
130	25.2	63.0	10000	8900	3000	
140	10.7	29.6	7900*	7700	2400	

Hammer-Head Boom Peak

Load In Pounds

Boom Radius Feet	Boom Angle Degrees	Boom Peak Height Feet	With Outriggers		Without Outriggers	
			Over Rear	Over Side	Over Rear	Over Side
148 Ft. Boom						
35	79.1	151.7	61100*	61100*	29400	23700
40	77.1	150.5	56800*	54500	24600	19600
50	73.1	147.6	41300	38900	18000	13900
60	68.9	144.0	31900	29700	13800	10300
70	64.7	139.4	25600	23600	10800	7800
80	60.3	133.9	21100	19300	8600	6000
90	55.6	127.4	17700	16100	6900	4600
100	50.7	119.5	15000	13600	5500	3400
110	45.4	110.2	12900	11600	4400	2500
120	39.5	98.8	11200	10000	3500	
130	32.8	84.4	9700	8600	2700	
140	24.3	65.1	8500	7500	2100	
150	10.3	30.4	6500*	6500*		
158 Ft. Boom						
35	79.8	161.9	57500*	57500*	29200	23500
40	77.9	160.8	53500*	53500*	24300	19300
50	74.2	158.1	41100	38700	17700	13700
60	70.3	154.7	31600	29500	13500	10100
70	66.4	150.5	25300	23400	10500	7600
80	62.3	145.5	20800	19100	8300	5700
90	58.1	139.5	17400	15800	6600	4300
100	53.7	132.4	14800	13300	5200	3200
110	48.9	124.1	12700	11300	4100	2300
120	43.8	114.1	10900	9700	3200	
130	38.2	102.2	9500	8300	2500	
140	31.6	87.2	8300	7200		
150	23.5	67.1	7200	6200		
160	10.0	31.2	5300*	5300*		
Load Ratings Below Include Jib						
168 Ft. Boom						
35	80.4	172.1	30000*	30000*	28900	23200
40	78.6	171.1	30000*	30000*	24000	19000
50	75.1	168.6	30000*	30000*	17500	13400
60	71.6	165.4	30000*	29200	13200	9800
70	67.9	161.5	20000*	20000*	10200	7300
80	64.1	156.8	20000*	18800	8000	5400
90	60.2	151.3	17200	15600	6300	4000
100	56.2	144.8	14500	13100	5000	2900
110	51.9	137.2	12400	11100	3900	2000
120	47.3	128.4	10700	9400	3000	
130	42.4	118.0	9200	8100	2200	
140	36.9	105.4	8000	6900		
150	30.6	89.9	6900	5900		
160	22.7	69.0	6000	5100		
178 Ft. Boom						
40	79.3	181.3	30000*	30000*	23800	18700
50	76.0	178.9	30000*	30000*	17200	13100
60	72.6	175.9	30000*	29000	12900	9500
70	69.2	172.3	20000*	20000*	9900	7000
80	65.7	167.9	20000*	18600	7700	5200
90	62.1	162.8	16900	15300	6000	3700
100	58.3	156.8	14300	12800	4700	2600
110	54.4	149.9	12100	10800	3600	
120	50.3	141.9	10400	9200	2700	
130	45.9	132.6	9000	7800		
140	41.1	121.7	7700	6700		
150	35.8	108.6	6700	5700		
160	29.7	92.5	5800	4800		
180	9.3	32.7	3100*	3100*		

Boom Radius Feet	Boom Angle Degrees	Boom Peak Height Feet	With Outriggers		Without Outriggers	
			Over Rear	Over Side	Over Rear	Over Side
188 Ft. Boom						
40	79.9	191.5	30000*	30000*	23500	18500
50	76.8	189.3	30000*	30000*	16900	12900
60	73.6	186.4	30000*	28700	12600	9200
70	70.4	183.0	20000*	20000*	9700	6700
80	67.1	178.9	20000*	18300	7500	4900
90	63.7	174.1	16600	15100	5800	3500
100	60.2	168.6	14000	12600	4400	2300
110	56.6	162.2	11900	10600	3300	
120	52.8	154.8	10100	8900	2400	
130	48.8	146.4	8700	7600		
140	44.6	136.7	7500	6400		
150	39.9	125.3	6400	5400		
160	34.8	111.7	5500	4600		
180	21.4	72.7	4000	3200		
198 Ft. Boom						
40	80.4	201.7	21000*	21000*	21000*	18200
50	77.4	199.6	21000*	21000*	16600	12600
60	74.4	196.9	21000*	21000*	12400	9000
70	71.4	193.6	14000*	14000*	9400	6500
80	68.3	189.8	14000*	14000*	7200	4600
90	65.1	185.3	14000*	14000*	5500	3200
100	61.9	180.1	13700	12300	4100	2100
110	58.5	174.2	11600	10300	3000	
120	55.0	167.4	9900	8700	2100	
130	51.3	159.6	8400	7300		
140	47.5	150.8	7200	6100		
150	43.3	140.6	6100	5200		
160	38.9	128.8	5200	4300		
180	28.1	97.4	3700	2900		
208 Ft. Boom						
45	79.5	210.9	15000*	15000*	15000*	14800
50	78.0	209.8	15000*	15000*	15000*	12300
60	75.2	207.3	15000*	15000*	12100	8700
70	72.3	204.2	10000*	10000*	9100	6200
80	69.4	200.6	10000*	10000*	6900	4300
90	66.4	196.3	10000*	10000*	5200	2900
100	63.3	191.5	10000*	10000*	3900	
110	60.2	185.9	10000*	10000*	2800	
120	56.9	179.6	9600	8400		
130	53.5	172.4	8200	7000		
140	50.0	164.3	6900	5900		
150	46.2	155.0	5900	4900		
160	42.2	144.4	5000	4000		
180	33.0	117.6	3500	2600		
200	20.3	76.2	2300			
218 Ft. Boom						
45	79.9	221.1	12000*	12000*	12000*	12000*
50	78.6	220.1	12000*	12000*	12000*	12000*
60	75.9	217.7	12000*	12000*	11800	8400
70	73.2	214.7	8000*	8000*	8000*	5900
80	70.4	211.3	8000*	8000*	6600	4100
90	67.6	207.3	8000*	8000*	4900	2600
100	64.7	202.7	8000*	8000*	3600	
110	61.7	197.4	8000*	8000*	2500	
120	58.6	191.5	8000*	8000*		
130	55.5	184.8	7900	6800		
140	52.2	177.3	6700	5600		
150	48.7	168.8	5600	4600		
160	45.1	159.1	4700	3800		
180	36.9	135.4	3200	2400		
200	26.7	102.1	2000			

(Continued on next page)

MC-7125

Hammer-Head Boom Peak

11. More than one part hoist line must be used on any boom when lifting radius is less than 20 ft.
12. Mast not required, but may be used with raised gantry.
13. Maximum length of boom (without jib).....158 ft.
14. With gantry in raised position (21 ft. 9½ in. overall height), the following maximum lengths may be carried* over rear in low-low gear without outriggers:

158 ft. boom without jib	148 ft. boom and 40 ft. jib
158 ft. boom and 30 ft. jib	138 ft. boom and 60 ft. jib
15. With gantry in lowered position or gantry lowered and mast pinned to the base section, (12 ft. 11½ in. overall height less jib) (16 ft. 1 in. with jib) the following maximum boom lengths may be carried over the rear without outriggers:

108 ft. boom without jib	68 ft. boom and 60 ft. jib
78 ft. boom and 30 ft. jib	
16. With outriggers set and gantry in raised position, the following maximum boom lengths may be raised unassisted, from the horizontal over the rear:

158 ft. boom without jib
158 ft. boom plus 60 ft. jib
17. Hoist Cable Reeving:

Number of Parts of Hoist Lines	1	2	3	4	5	6	7	8	9	10	11	12
Maximum Loads (Lbs.)	22000	44000	66000	88000	110000	132000	154000	176000	198000	220000	242000	250000

Use ¼" dia. hoist cable (6 x 25, IWRC) of 39.8 tons breaking strength.



Koehring
Crane and Excavator Group
Lorain Products

SIMS CRANE SERVICE, INC.
P.O. BOX 11825

Sold By:

Tampa, Florida 33680	(813) 626-8102
Bradenton, Florida	(813) 756-9506
Ft. Lauderdale, Florida	(305) 491-3401
Jacksonville, Florida	(904) 358-8697
Orlando, Florida	(305) 851-2930
Atlanta, Georgia	(404) 696-6838
Augusta, Georgia	(404) 790-4380
Columbia, South Carolina	(803) 796-6810

SIMS CRANE & EQUIPMENT CO.
5002 E. HILLSBOROUGH AVE.
TAMPA FL. 33610
(813) 626-8102