



Custom Built Marine & Offshore Cranes

**FIX BOOM CRANE**

# HMR 150/24F **MODEL**

## TECHNICAL SPECIFICATION

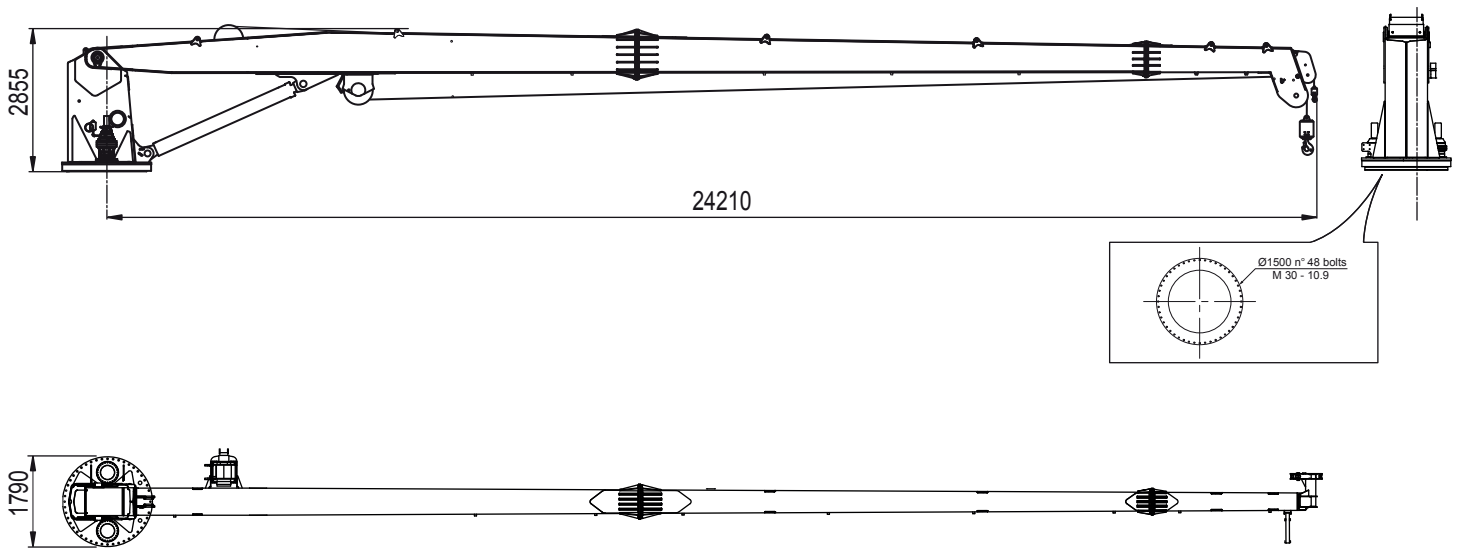

TECHNICAL DATA					
Articulated booms	N°	1	Empty weight of the crane	kg	12800
Max bending moment	daNm	240.000	Recommended amount of oil	lt	380
Max Slewing torque	daNm	18.000	Slewing speed	rpm	0,5
Slewing angle (continuous)	°	360	Main boom lifting time	sec	68
Pump capacity	lt/min	120	Max allowable wear	mm	2,8
Max working pressure	bar	260			
STANDARD FEATURES					
4 function Hawe hydraulic valve			Max wind speed during goods lifting: 20 m/s (70 km/h)		
Max pressure valve on the oleodynamic circuit			Max wind speed during personnel lifting: 10 m/s (36 km/h)		
Stop control valve on the cylinders					
5000 kg double pull winch with 100 m of rope Ø 18 mm					
1500 kg personnel lift winch with 600 m of rope Ø 13 mm					
Working temperature from -10°C to +45°C					

The technical data contained in this card are only indicative and can be changed without notice.

HEILA CRANES S.p.A. | Via Romana 34/6 - 42028 Poviglio (RE) Italy | info@heila.com | www.heila.com



Custom Built Marine & Offshore Cranes

FIX BOOM CRANE

# HMR 150/24F MODEL

## TECHNICAL SPECIFICATION

(ONLY FOR USE WITH HOOK - SEA STATE - 0 - OR HARBOUR CONDITION)

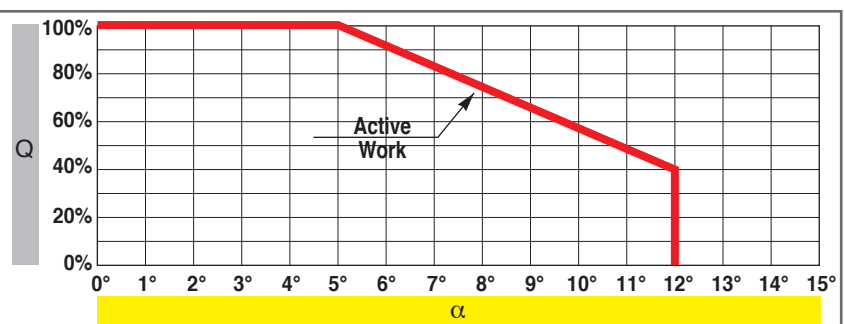
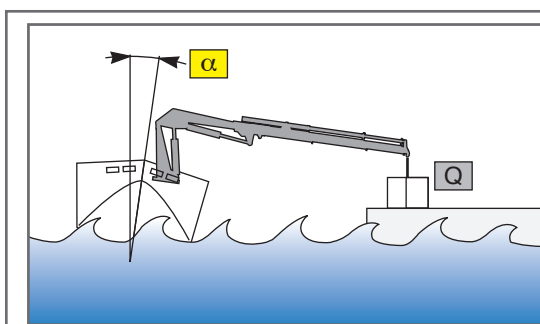
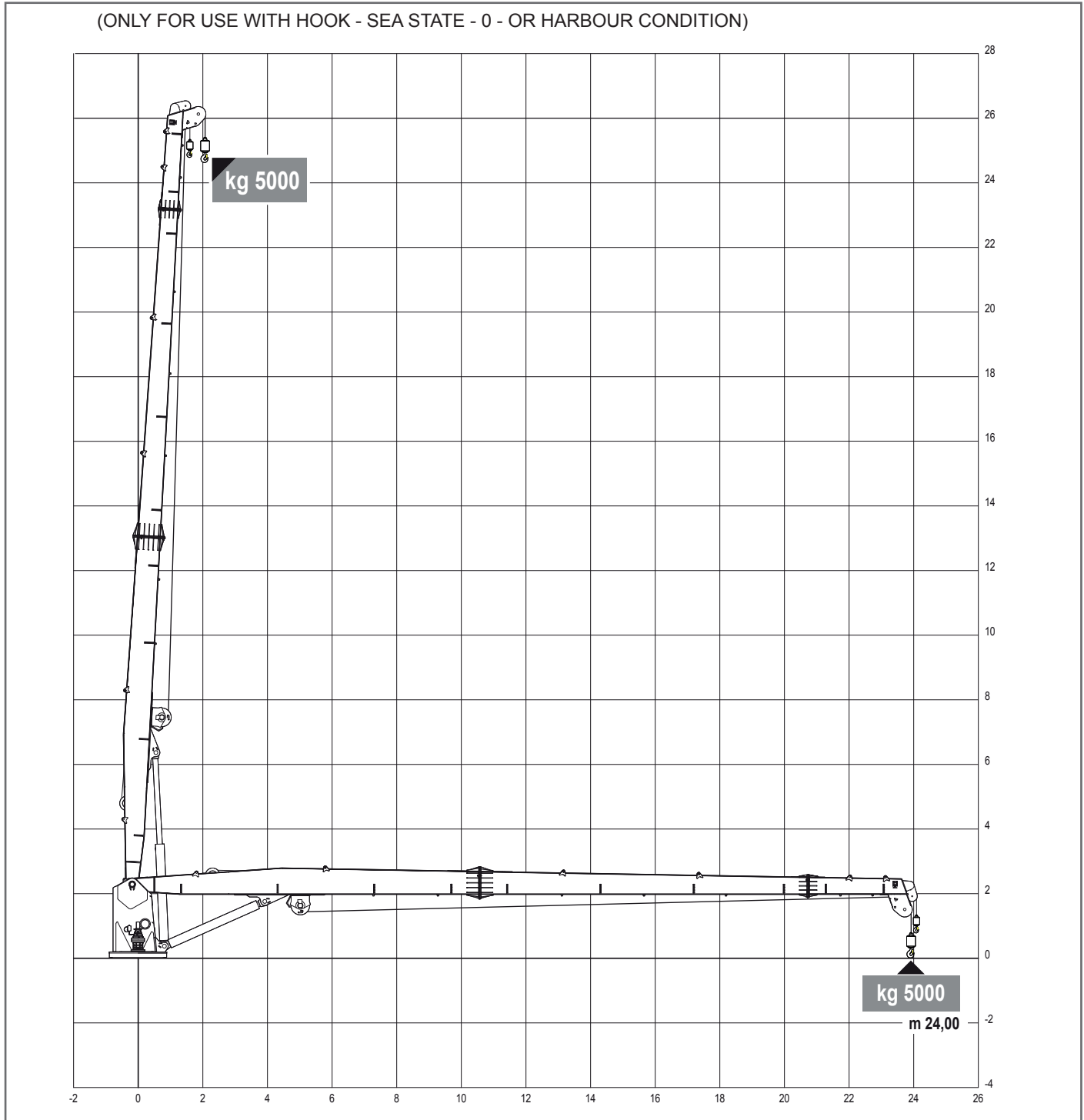

The technical data contained in this card are only indicative and can be changed without notice.