

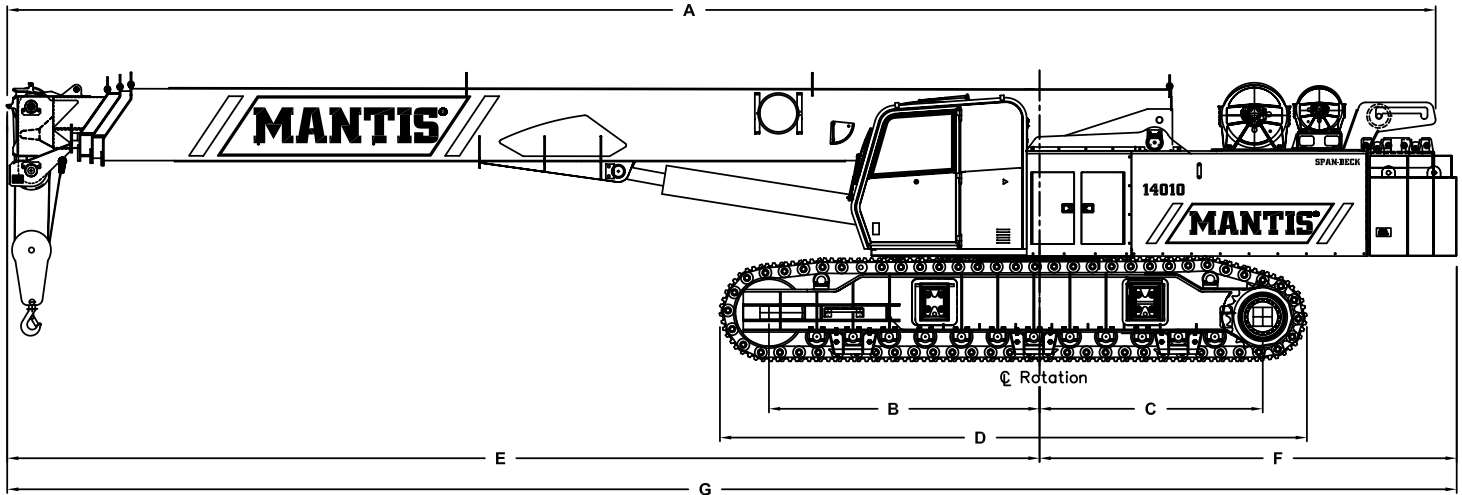

SPECIFICATIONS

MANTIS® 14010 70 TON TELE-BOOM CRAWLER CRANE



PRINCIPAL DIMENSIONS

A	Length (Counterweight Removed)	48 ft 3 in (14.71 m)
B	CL Front Track Drive to CL Rotation	9 ft 5 in (2.87 m)
C	CL Rear Track Drive to CL Rotation	7 ft 9 in (2.36 m)
D	Track Length	20 ft 5 in (6.22 m)
E	Boom Length to CL Rotation	34 ft 6 in (10.52 m)
F	Tailswing	14 ft 6 in (4.42 m)
G	Overall Length	49 ft 0 in (14.94 m)
H	Ground to Top of Engine Cover	8 ft 5 in (2.57 m)
I	Track Height	44 in (1.12 m)
J	Ground Clearance	12 in (305 mm)
K	Ground to Bottom of Cab	48 in (1.22 m)
L	Maximum Overall Height	10 ft 4 in (3.15 m)
M	Track Width	36 in (900 mm)
N	Overall Width (Tracks Retracted)	12 ft 6 in (3.81 m)
O	Overall Working Width	18 ft 8 in (5.69 m)

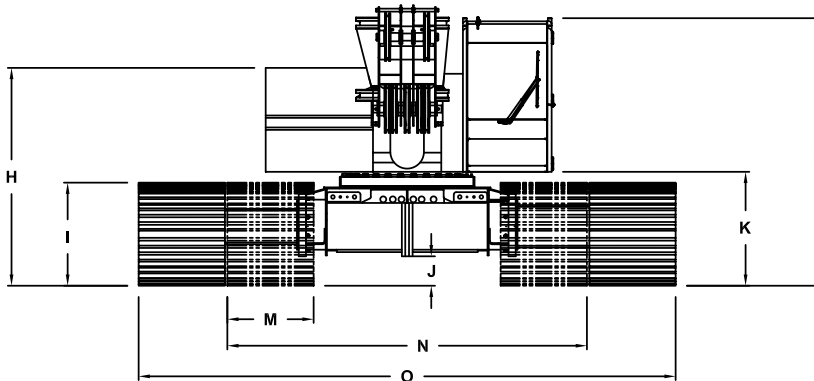

WIDTHS, WEIGHTS, AND GROUND PRESSURES*

Shoe Width	Overall Width		Area	Ground Pressure	Working Weight
	Retracted	Extended			
24 in (609 mm)	11 ft 6 in (3.51 m)	17 ft 8 in (5.39 m)	9,900 in ² (6.38 m ²)	13.0 psi (0.91 kg/cm ²)	128,490 lb (58,280 kg)
30 in (762 mm)	12 ft 0 in (3.66 m)	18 ft 2 in (5.54 m)	12,360 in ² (7.97 m ²)	10.5 psi (0.74 kg/cm ²)	130,330 lb (59,120 kg)
36 in (900 mm)	12 ft 6 in (3.81 m)	18 ft 8 in (5.69 m)	14,850 in ² (9.57 m ²)	8.9 psi (0.63 kg/cm ²)	132,154 lb (59,940 kg)

* Crane equipped with: 111 ft 6 in boom, extension, jib, 70 ton hook block and 12 ton headache ball



SPECIFICATIONS

MANTIS® 14010 70 TON TELE-BOOM CRAWLER CRANE

STANDARD CRANE AND EQUIPMENT

Boom

The boom consists of four full powered sections, 37 ft 6 in (11.43 m) retracted to 111 ft 6 in (33.99 m) fully extended. Maximum tip height is 117 ft (35.66 m).

Boom Telescoping & Elevating Systems

The telescoping system features two double-acting hydraulic cylinders and counterbalance lock valves. The elevating system features a cylinder and counterbalance lock valve which provide boom elevations from -1° to 78°.

Boom Head

Seven 19 in (483 mm) diameter, cast nylon sheaves on heavy-duty roller bearings are mounted in the boom head.

SUPERSTRUCTURE

Frame

The frame is an all-steel, welded structure, precision machined to accept attachment of the boom and swing components.

Operator's Cab

The fully-enclosed, air conditioned all-steel modular cab includes a lockable swinging door, acoustical lining, anti-slip floor and tinted safety glass. Sliding windows are located in the cab door and cab boom side. A vent window is positioned in the rear of the cab. Grab bars and steps are appropriately located for easy access to the cab. Erectable swing barricades are attached to the superstructure. Rear view cameras are appropriately located as are work lights.

Standard cab accessories include a two-speed windshield wiper, top glass wiper, defroster, heater, circulating fan, adjustable hand and foot throttles, six-way adjustable fabric seat with headrest, seat belt, dome light, and a dry-chemical fire extinguisher.

Instrumentation

Dash instrumentation features a tachometer, voltmeter, oil pressure gauge, temperature gauge, hour meter and fuel gauge. Indicators are provided for crane level, load moment, drum rotation, air filter restriction, hydraulic oil temperature and filter restriction, engine oil pressure and temperature.

A termination switch is located in the seat and armrest and is capable of immediately disabling all hydraulic functions as the operator rises from the seat or it can be activated by lifting the left hand armrest.

Control

Two-way hydraulic joysticks mounted in the operator's seat armrests control swing, auxiliary hoist, main winch and boom hoist. Four two-way hydraulic foot pedals control travel, swing service brake and boom telescoping functions. Travel pedal hand levers are available as an option. A fifth pedal controls engine speed.

Counterweight

The 30,000 lb (13,610 kg) counterweight system consists of two 15,000 lb (6,805 kg) pieces. Each can be removed and installed via a pendant attached to the boom.

Load Moment Indicator & Anti-Two Block¹

Standard Rated Capacity Limiter and Anti-Two Block system with audio-visual warning and control function shutdown. System's LCD screen provides a continuous electronic display of working boom length, boom angle, working load radius, tip height, parts-of-line (operator set), machine configuration, relative load moment, maximum permissible load and actual load.

The standard Work Area Definition system allows the operator to pre-set and define working areas. Should pre-set limits be approached, audio-visual warnings aid the operator in avoiding job-site obstructions. The anti-two block weight allows quick reeving of hook blocks.

Swing

The superstructure rotates 360° around a shear ball slew bearing with an external gear that matches with the swing drive pinion and bolts to the superstructure and the carbody. The hydraulic swing drive powers the system and consists of a gear motor driving into a planetary reducer with a shaft mounted pinion providing infinitely variable speeds of up to 3 rpm.

Swing braking is achieved through a "failsafe", hydraulically released, spring applied, multi-disc wet brake which includes a foot applied service brake. The brake can be electrically actuated through a cab mounted switch into a "locked-on" (parking) mode. A two position house lock system is included. Regular lubrication of the bearing is achieved through a cab mounted grease applicator.

Fuel System

A 100 US gal (378 l) tank is bolted to the superstructure. The fuel filtration system consists of an inline fuel/water separator as well as an engine mounted fuel filter.

Hydraulic System

The load sensing, open-loop hydraulic system is served by two variable volume pumps mounted in tandem. The pumps are horsepower limiting and pressure compensated providing a maximum output of 168 gpm (636 l/min) @ 2,200 rpm and maximum operating pressure of 4,850 psi (339.5 kg/cm²). An extra circuit is included for ready adaptation to hydraulic accessories.

The system includes two pilot operated valve banks that are pressure and flow compensated. The 300 US gal (1,136 l) capacity hydraulic oil reservoir has a spin-on filler-breather cap, external sight gauge, clean-out access and a sump type drain. An air to oil remote mounted cooler provides oil cooling with thermostatically-controlled, electrically driven fans. Hydraulic oil filtering is achieved with two 5 micron full flow cartridge type filters designed to return in-tank with bypass protection and an electronic bypass indicator.

(System pressure test ports with quick disconnect fittings are provided for diagnostics.)



SPECIFICATIONS

70 TON TELE-BOOM CRAWLER CRANE

MAIN HOIST

Planetary geared two-speed winch includes a bent axis, variable displacement hydraulic motor and a multi-disc internal brake.										
Rope Layer	Maximum Line Pull		Full Load Line Speed		Pitch Diameter		Layer		Total	
1	21,400 lb	9,707 kg	158 ft/min	48 m/min	16.8 in	425.4 mm	109.0 ft	33.2 m	109.0 ft	33.2 m
2	19,540 lb	8,863 kg	173 ft/min	53 m/min	18.1 in	459.4 mm	203.0 ft	62.0 m	228.0 ft	69.5 m
3	17,970 lb	8,151 kg	188 ft/min	57 m/min	19.4 in	493.4 mm	220.0 ft	67.0 m	358.0 ft	109.0 m
4	16,640 lb	7,548 kg	204 ft/min	62 m/min	20.8 in	527.4 mm	237.0 ft	72.0 m	498.0 ft	152.0 m
5	15,490 lb	7,026 kg	219 ft/min	67 m/min	22.1 in	561.3 mm	253.0 ft	77.0 m	649.0 ft	198.0 m
6	14,500 lb	6,577 kg	234 ft/min	71 m/min	23.4 in	595.3 mm	270.0 ft	82.0 m	810.0 ft	247.0 m

AUXILIARY HOIST

Planetary geared two-speed winch includes a bent axis, variable displacement hydraulic motor and a multi-disc internal brake. Wire Rope: 350 ft (107 m) 3/4" (19 mm) 6 x 37 EIPS, IWRC, RRL. Line pulls are not based on wire rope strength. Drum rotation indicator is standard.										
Rope Layer	Maximum Line Pull		Full Load Line Speed		Pitch Diameter		Layer		Total	
1	17,500 lb	7,940 kg	180 ft/min	54.9 m/min	11.5 in	292.1 mm	64.0 ft	19.6 m	64.0 ft	19.6 m
2	15,400 lb	6,990 kg	197 ft/min	60.0 m/min	12.8 in	326.1 mm	72.0 ft	21.9 m	136.0 ft	41.4 m
3	13,800 lb	6,260 kg	208 ft/min	63.4 m/min	14.2 in	360.0 mm	79.0 ft	24.1 m	215.0 ft	65.6 m
4	12,500 lb	5,670 kg	219 ft/min	66.8 m/min	15.5 in	394.0 mm	87.0 ft	26.4 m	302.0 ft	92.0 m
5	11,500 lb	5,220 kg	235 ft/min	71.6 m/min	16.8 in	428.0 mm	94.0 ft	28.7 m	396.0 ft	120.6 m

STANDARD ENGINE

Cummins QSB240 (U.S. EPA Tier 3)					
Noise Emissions: Top 96.3 dBA (excludes noise from intake, exhaust, cooling system and driven components)					
Type	6 Cylinder Water Cooled	Weight (Wet)	1056 lb (479 kg)	Aspiration	Turbocharged & Aftercooled
Displacement	360 cu in (5.9 l)	Oil Capacity	17.2 US quarts (16.3 l)	Air filter	Dry Type
Bore	4.02 in (102 mm)	Rated Horsepower	240 (179 kw) @ 2200 rpm	Electrical	12 volt
Stroke	4.72 in (120 mm)	Peak Torque	652 ft-lb (884 Nm) @ 1500 rpm	Alternator	100 amp

MACHINE WEIGHTS

STANDARD CRANE WITH 4 SECTION 111 ft 6 in (33.99 m) BOOM, 2 PIECE COUNTERWEIGHT & 36 in (914 mm) TRACK SHOES	127,750 lb	57,950 kg
Crane Less Counterweights and Track Frames	61,300 lb	27,810 kg
Counterweight, 2 pieces 15,000 lb (6,805 kg) each	30,000 lb	13,610 kg
Track Frames, 2 pieces 18,000 lb (8,165 kg) each	36,000 lb	16,330 kg
OPTIONAL EQUIPMENT		
Alternative Boom 54 ft (16.46 m) three section boom in place of standard boom**	(8,300) lb	(3,760) kg
Alternative Boom 40 ft (12.19 m) two section boom in place of standard boom**	(11,900) lb	(5,400) kg
30 ft (9.14 m) Lattice Extension	1,700 lb	771 kg
20 ft (6.10 m) Jib (connects to head of Lattice Extension ONLY)	700 lb	318 kg
Auxiliary Winch with Standard Rope	962 lb	436 kg
Auxiliary Nose Sheave	210 lb	95 kg
12 ton (11 mt) Headache Ball	404 lb	200 kg
70 ton (64 mt) Hook Block	1,600 lb	726 kg
Auger Ready Package	440 lb	200 kg
Complete Auger Package	1,520 lb	690 kg
60 in (1.52 m) Auger Kelly Bar	120 lb	54 kg
72 in (1.83 m) Auger Kelly Bar	140 lb	64 kg

* Deduction from Standard Crane Weight

70 TON TELE-BOOM CRAWLER CRANE

UNDERCARRIAGE

Carbody

The welded steel, box type carbody is fabricated with square axles to accept the crawler side frames. The top surface is precision machined to receive the swing bearing.

Side Frames

Two welded steel removable side frames are paired with a track group consisting of twelve bottom and two top oil-filled & sealed rollers. Each frame includes an oil-filled, self-lubricating idler and spring type, track tensioning device. Standard track shoes are 36 in (900 mm) wide, 3-bar semi-grousers. Optional shoes are available in 30 in (762 mm) width flat pad and semi-grouser configuration; 36 in flat pads are also available. The side frames extend and retract hydraulically and are electrically controlled from the cab.

OPTIONAL EQUIPMENT

Booms

- **Three Section Boom:** hydraulically proportional full power boom, 26 ft (7.93 m) retracted to 54 ft (16.46 m) extended, maximum tip height of 55 ft 8 in (17.27 m).
- **Two Section Boom:** hydraulically proportional full power boom, 26 ft (7.93 m) retracted to 40 ft (12.19 m) extended, maximum tip height of 47 ft 10 in (14.58 m).

Boom Attachments

- **Boom Extension:** 30 ft (9.14 m) lattice type swingaway, stores alongside of the boom base section and used with or without the optional 20 ft (6.10 m) jib. Head contains two 19 in (483 mm) diameter high strength cast nylon sheaves mounted on heavy-duty roller bearings, reeving up to 2 parts of wire rope, with optional extension deployed maximum tip height is 147 ft (44.81 m).
- **Boom Jib:** 20 ft (6.10 m) lattice type swingaway, attaches to and stores alongside the extension and can only be used with the extension deployed. Offsets are at 15° & 30°; with optional jib and extension deployed maximum tip height is 167 ft (50.90 m).
- **Auxiliary Nose Sheave:** quick reeve, single 19 in (483 mm) diameter high-strength, cast nylon sheave mounted on a heavy-duty roller bearing boom tip adapter.
- **Wire Rope:** rotation resistant, (non-spin) Dyform-18 HSLR.
- **Headache Ball:** 12 ton (11 mt) ball includes a swivel hook with safety latch.
- **Hook Block:** 70 ton (63 mt) hook block consists of five 19 in (483 mm) diameter sheaves mounted on heavy-duty roller bearings with a swivel hook and safety latch.

Travel

Each side frame contains a pilot controlled, two-speed track drive. The drives are hydraulic piston motors which propel the crane at a low speed of 1.5 mph (2.4 km/hr) and at a high speed of 2.5 mph (4.0 km/hr). The internal brake system is spring applied and automatically released upon actuation of the travel system.

The hydraulic travel system provides skid steering and track counter rotation and achieves an unladen gradeability of 46%.

Hydraulic

- **Auxiliary Hoist:** planetary geared two-speed winch includes a bent axis, variable displacement hydraulic motor and a multi-disc internal brake.
- **Auger Ready Package:** includes hoses, fasteners and stowage bracket assembly mounted to the base section of the boom with a flow capability of 34 gpm (130 l/min).
- **Complete Auger Package:** adds a two speed auger motor/gear box and one 60 in (1.52 m) kelly bar to the Auger Ready Package.
- **Tool Circuit:** provides 6 gpm (23 l/min) and 12 gpm (45 l/min) at 2,500 psi (176 kg/cm²) through a 50 ft (15.24 m) twin hose reel with quick disconnect fittings to operate open center tools.

Other Options

- **Free Fall Hoists:** all winches are available in free fall and controlled free fall configurations.
- **Crane Cab Access Walkways:** a pair of 54.5 in (1 384 mm) wide x 25 in (635 mm) deep walkways which attach to both the front and rear of the carbody and allow for easier egress and ingress to the operator's cab when the crane's upper rotating frame is not aligned front to rear.
- **Model WP750 Work Platform:** 36 in x 72 in (914 mm x 1 828 mm), all-steel, welded, two-person platform with a maximum capacity of 750 lb (340 kg). A test weight and boom head adapter are included in the package. Operation and control are by the crane operator from the cab. Radio (RF) controls to enable remote operation from the platform are available.

(See separate WP750 Specification for a complete description of standard and optional Work Platform equipment.)

*Load moment indicating and anti-two block systems are operator aids and must never be used in lieu of job site lift planning calculations by the operator which must take into account ground conditions, weather and all other environmental factors prevailing at the time of the lift. Prices and specifications are subject to change at any time without prior notice and are for factory installation at time of original manufacture. F.O.B Plant; Richlands, VA 24641. Illustrations and photographs may show optional equipment. Supercedes all previous issues. Please see www.mantiscranes.com for most current information.