Manual # 99904607

13/88SL Technical Specifications

Revision Date 20120503



IOWA MOLD TOOLING CO., INC.

PO Box 189

Garner, IA 50438

Tel: 641-923-3711 FAX: 641-923-2424

Website: <http://www.imt.com>

Copyright © 2012 Iowa Mold Tooling Co., Inc.
All rights reserved

No part of this publication may be reproduced, stored in a retrieval system, or transmitted in any form or by any means, electronic, mechanical, photocopying, recording or otherwise without the prior written permission of Iowa Mold Tooling Co., Inc.

Iowa Mold Tooling Co., Inc. is an Oshkosh Corporation company.

Contents

Revisions	ii
Technical Data and Charts	3
13/88SL Specifications	4
13/88SL Pressure Settings	5
13/88SL K1 Capacity Chart.....	6
13/88SL K2 Capacity Chart.....	7
13/88SL K3 Capacity Chart.....	8
13/88SL K4 Capacity Chart.....	9
13/88SL K5 Capacity Chart.....	10
13/88SL K6 Capacity Chart.....	11
13/88SL Geometric Configuration	12
Stabilizer Dimensions, Fixed Legs	13
Stabilizer Dimensions, Hyd Swing-Up Legs	14
13/88SL Swing Clearance	15
Hydraulic Schematics	17
Hydraulic Diagram - 13/88SL Manual Control	18
Hydraulic Diagram - 13/88SL Radio Control.....	19
Hydraulic Diagram- 13/88SL Top Seat Control	20

Revisions

DATE	LOCATION	DESCRIPTION
20090813		ADDED SWING CLEARANCE DRAWING
20100118	Geometric. configuration	Added stabilizer length and extension dimensions, stabilizer drawings.
20111213	Specs, Stabilizer drawings	ECN 11628 – Updated stabilizer wording.
20120502	Specifications	Updated weight to include mounting bolt, tank.

CHAPTER 1

Technical Data and Charts

In This Chapter

13/88SL Specifications.....	3
13/88SL Pressure Settings.....	5
13/88SL K1 Capacity Chart.....	6
13/88SL K2 Capacity Chart.....	7
13/88SL K3 Capacity Chart.....	8
13/88SL K4 Capacity Chart.....	9
13/88SL K5 Capacity Chart.....	10
13/88SL K6 Capacity Chart.....	11
13/88SL Geometric Configuration	12
Stabilizer Dimensions, Fixed Legs	13
Stabilizer Dimensions, Hyd Swing-Up Legs	14
13/88SL Swing Clearance.....	15

13/88SL Specifications

13/88SL	1-HYDRAULIC	2-HYDRAULIC	3-HYDRAULIC	4-HYDRAULIC	5-HYDRAULIC	6-HYDRAULIC
Crane Rating*	88,245 ft lb (12.2 tm)	84,625 ft lb (11.7 tm)	81,735 ft lb (11.3 tm)	78,840 ft lb (10.9 tm)	75,945 ft lb (10.5 tm)	73,055 ft lb (10.1 tm)
Maximum Horizontal Reach	20' 4" (6.2 m)	27' 3" (8.3 m)	34' 1" (10.4 m)	41' 8" (12.7 m)	48' 11" (14.9 m)	56' 5" (17.2 m)
Maximum Vertical Reach	28' 7" (8.7 m)	35' 5" (10.8 m)	42' 4" (12.9 m)	49' 10" (15.2 m)	57' 1" (17.4 m)	64' 8" (19.7 m)
Maximum Capacity	9,920 lb (4,500 kg)	9,920 lb (4,500 kg)	8,820 lb (4,000 kg)	8,820 lb (4,000 kg)	8,820 lb (4,000 kg)	8,820 lb (4,000 kg)
Max Cap @ Max Reach	4300 lb (1,950 kg)	3,020 lb (1,370 kg)	2,140 lb (970 kg)	1,520 lb (690 kg)	1,080 lb (490 kg)	750 lb (340 kg)
Crane Weight **	3,110 lb (1,410 kg)	3,415 lb (1,550 kg)	3,725 lb (1,690 kg)	4,025 lb (1,825 kg)	4,290 lb (1,945 kg)	4,495 lb (2,040 kg)
Hook Approach						
Vertical	9' 1" (2.76 m)	8' 11" (2.71 m)	8' 7" (2.62 m)	8' 4" (2.53 m)	8' 0" (2.44 m)	7' 9" (2.35 m)
Horizontal	2' 5" (0.74 m)	2' 7" (0.79 m)	2' 9" (0.84 m)	2' 11" (0.89 m)	3' 1" (0.94 m)	3' 3" (1.0 m)
Center of Gravity - Stored						
Vertical	2' 4" (700 mm)	2' 5" (730 mm)	2' 6" (755 mm)	2' 7" (785 mm)	2' 8" (805 mm)	2' 8" (820 mm)
Horizontal (C/L RotTo Bridge)	13.4" (340 mm)	13.2" (335 mm)	12.8" (325 mm)	12" (305 mm)	11.4" (290 mm)	11" (280 mm)

* Crane rating (ft-lb) is the rated load (lb) multiplied by the respective distance (ft) from centerline of rotation with all extensions retracted and the inner and outer booms in a horizontal position, per ANSI B30.22. ** Crane weight is for standard crane with tank & 4-bolt mounting kit. Does not include stabilizers, oil.

13/88SL SPECIFICATIONS	
Stabilizer Pad Diameter	6" (160 mm)
Crane Storage Height	7' 5" (2,250 mm)
Mounting Space ***	2' 8" (820 mm)
Rotational Torque	10,850 ft lb (1.5 tm)
Rotation	400°
Optimum Pump Performance	13.2 gpm (50 L/min)
System Pressure	4,350 psi (300 bar)
Oil Reservoir Capacity	23.8 gal (90 L)
Stabilizer Extension Span	
Standard (manual out / hydraulic down)	15' 2" (4,615 mm)
Weight	440 lb (200 kg)
Opt. 1 (manual out / hydraulic down)	18' 4" (5,590 mm)
Weight	520 lb (235 kg)
Opt. 2 (hydraulic out / hydraulic down)	21' 3" (6,470 mm)
Weight	660 lb (300 kg)
*** Maximum swing clearance radius required is 24" (600 mm) at 7'-10" (2375 mm) from top of chassis frame.	

MINIMUM CHASSIS SPECIFICATIONS	
Front Axle Rating (GAWR)	9,000 lb (4,080 kg)
Rear Axle Rating (GAWR)	18,500 lb (8,390 kg)
Resistance To Bending Moment	1,230,000 in-lb (141,710 kg-m)

13/88SL Pressure Settings

WORKING PRESSURE ON MAIN-RELIEF VALVES & PORT RELIEF VALVES			
<i>Function</i>	<i>Direction</i>	<i>Port</i>	<i>Pressure Setting</i>
Main-relief valve			4350 psi (300 bar)
Rotation system	Right	A	P
	Left	B	P
Boom cylinder	Down	A	1450 psi (100 bar)
	Up	B	4715 psi (325 bar)
Jib cylinder	Up	A	4715 psi (325 bar)
	Down	B	2900 psi (200 bar)
Extension cylinders	Extend	A	P
	Retract	B	P
Rotator	Right	A	2900 psi (200 bar)
	Left	B	2900 psi (200 bar)
Grab	Open	A	2900 psi (200 bar)
	Close	B	2900 psi (200 bar)
Separate stabilizer valve		All	2175 psi (150 bar)

WORKING PRESSURE ON LOAD-HOLDING VALVES			
<i>Function</i>	<i>Direction</i>	<i>Port</i>	<i>Opening Pressure</i>
Boom cylinder			4715 psi (325 bar)
Jib cylinder			4785 psi (330 bar)
Rotation system			2685 psi (185 bar)
Extension cylinders	Extend	A	3045 psi (210 bar)
	Retract	B	6235 psi (430 bar)

PRESSURE SETTING FOR LOAD-MOMENT LIMITATION (LMB)	
Load moment limitation (LMB)	4205 psi (290 bar)

MAXIMUM PUMP PERFORMANCE	
Pump performance	11.9 gal/min (45 l/min)

13/88SL K1 Capacity Chart

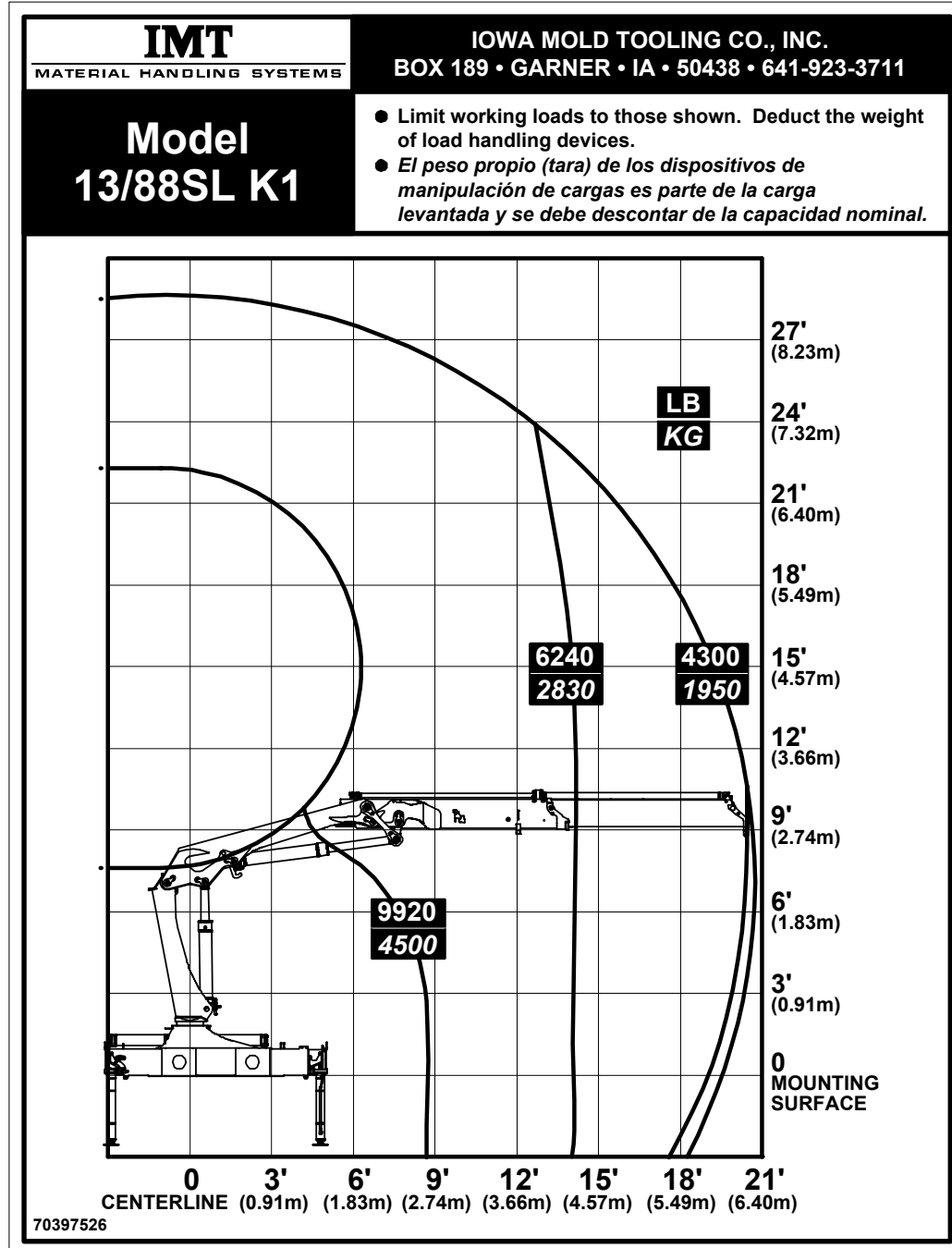

13/88SL K2 Capacity Chart

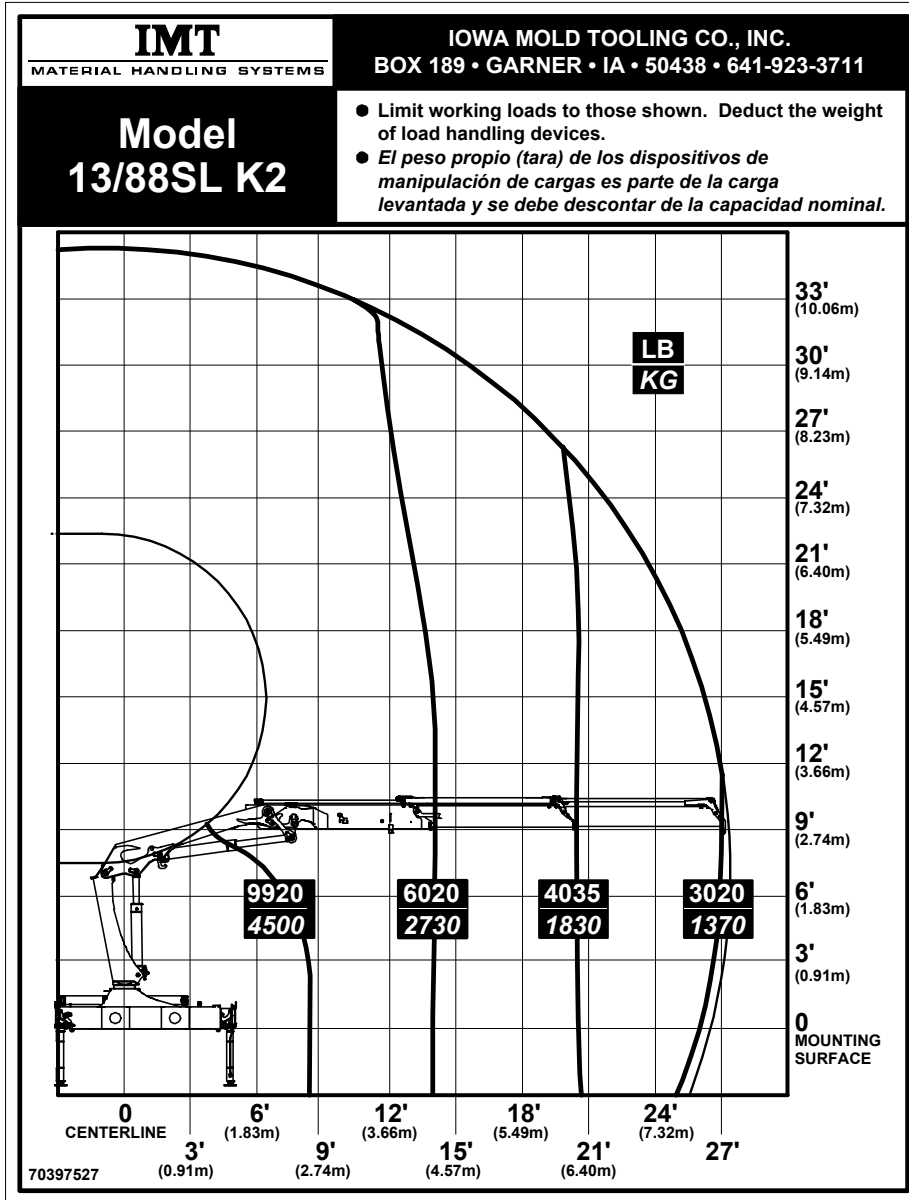

13/88SL K3 Capacity Chart

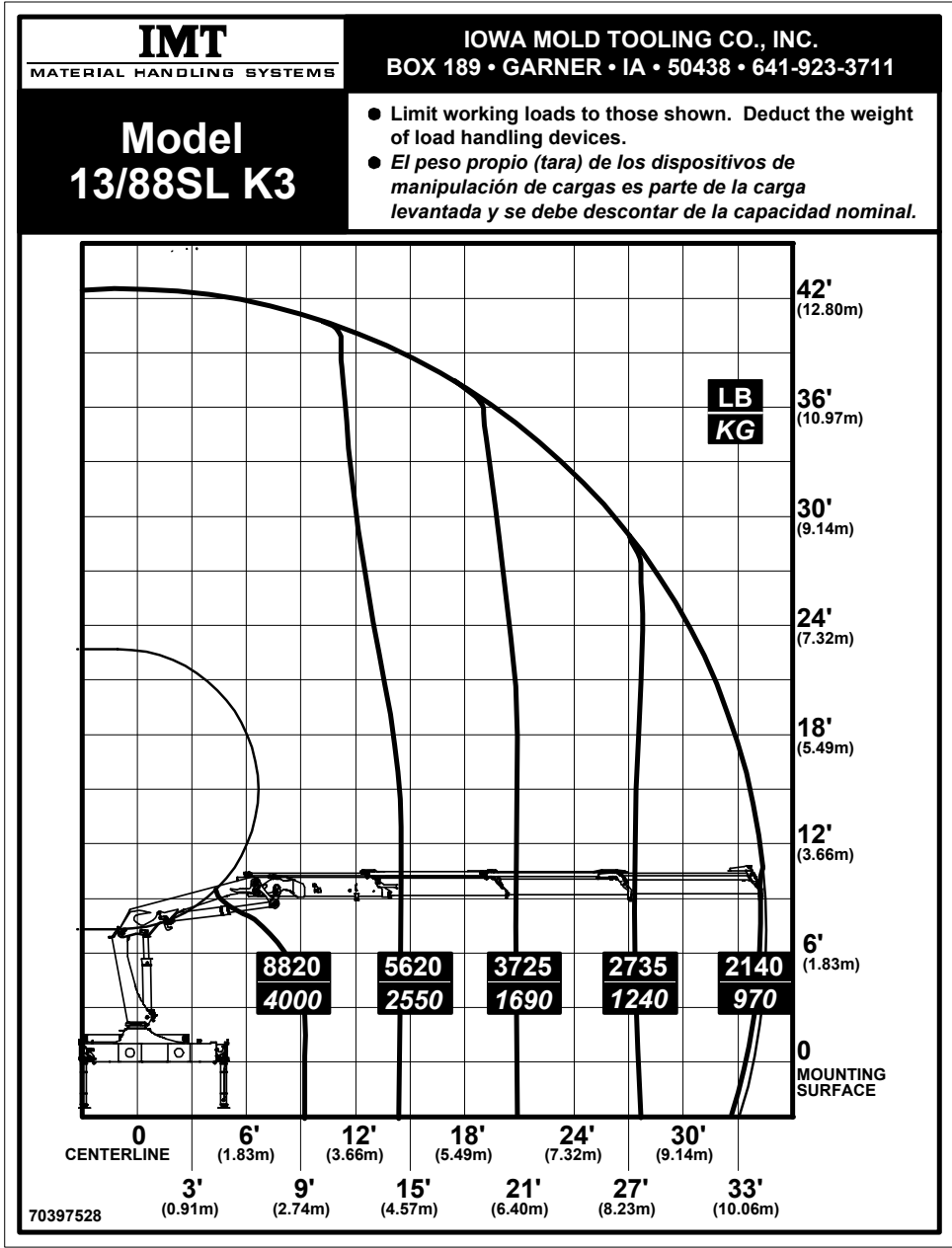

13/88SL K4 Capacity Chart

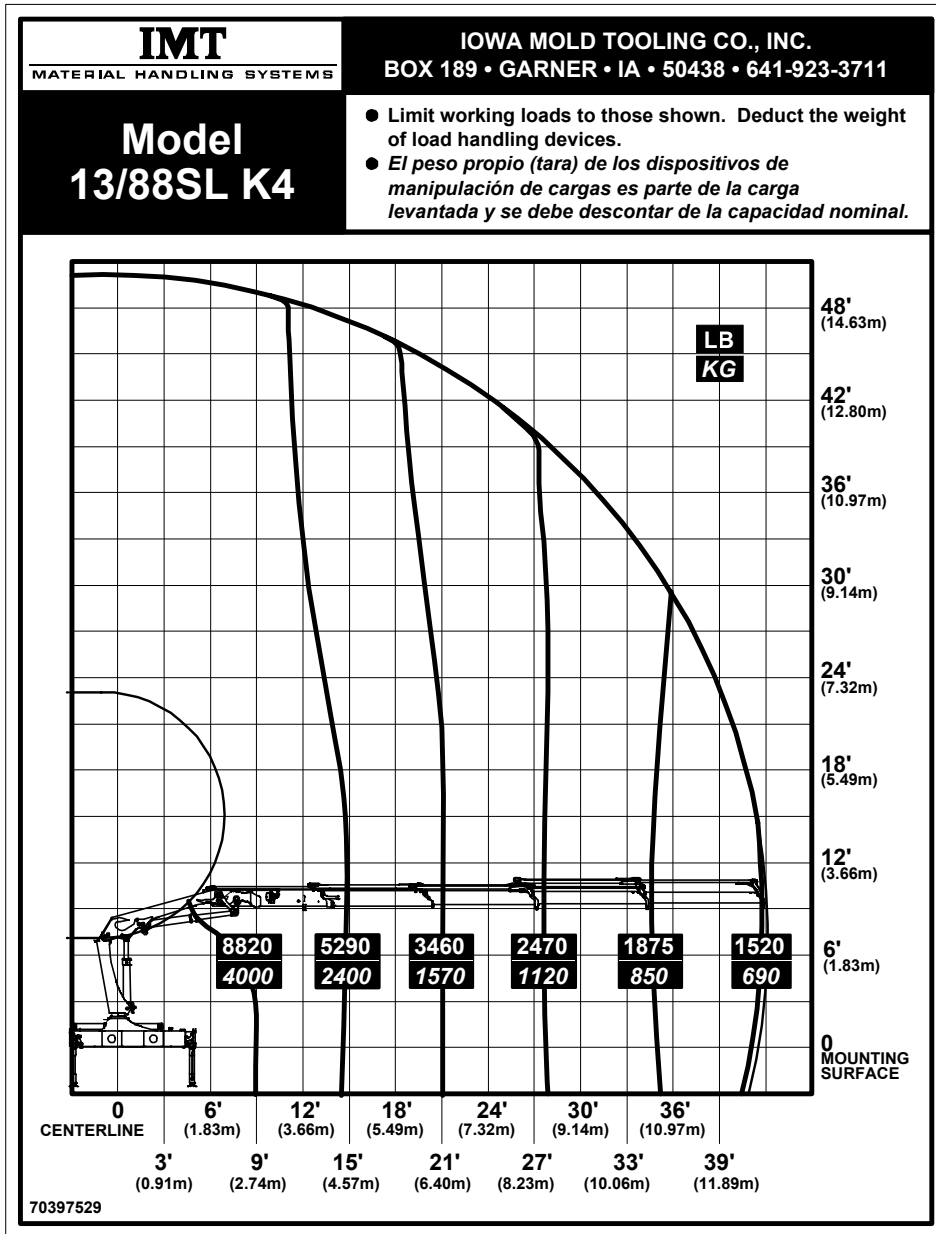

13/88SL K5 Capacity Chart

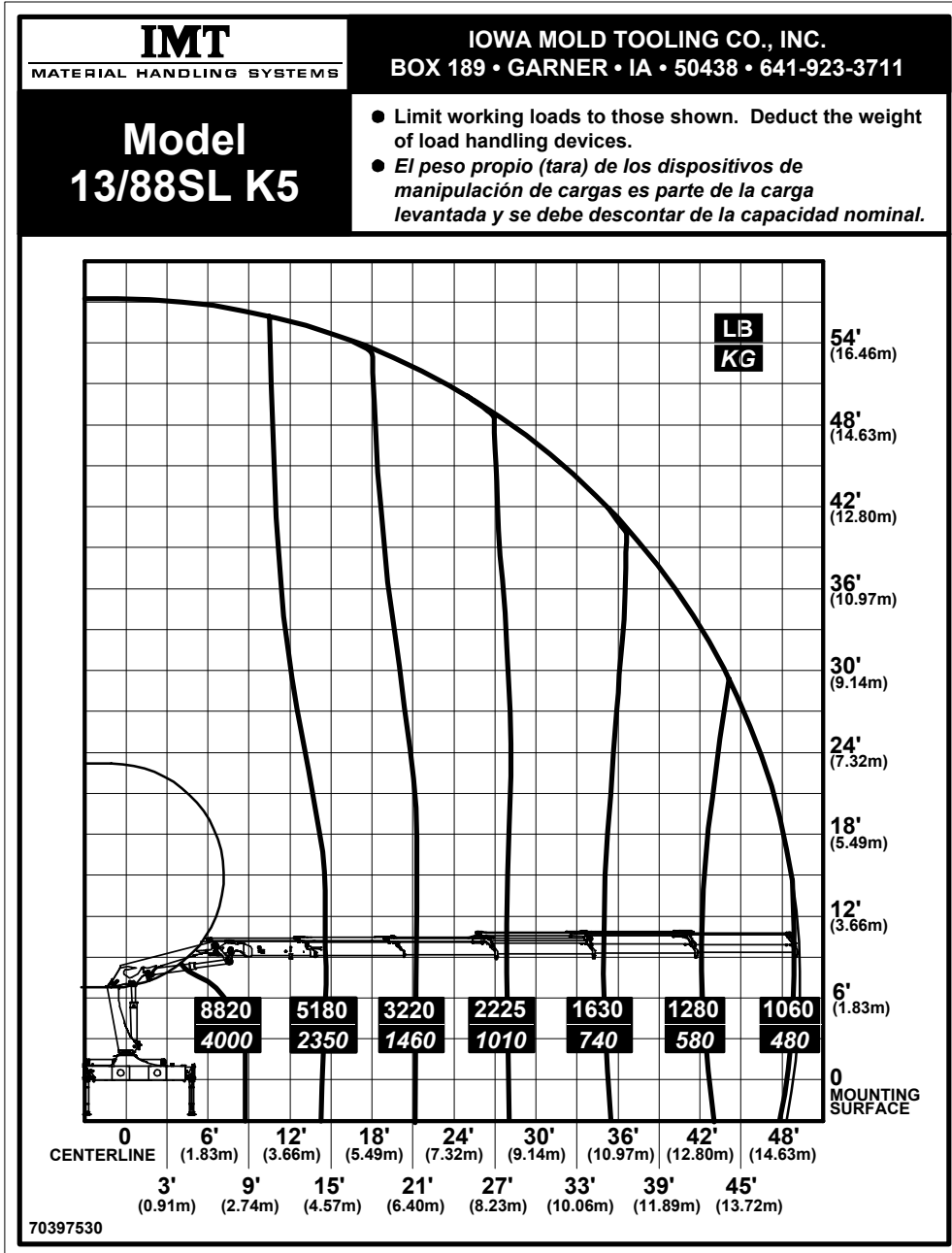

13/88SL K6 Capacity Chart

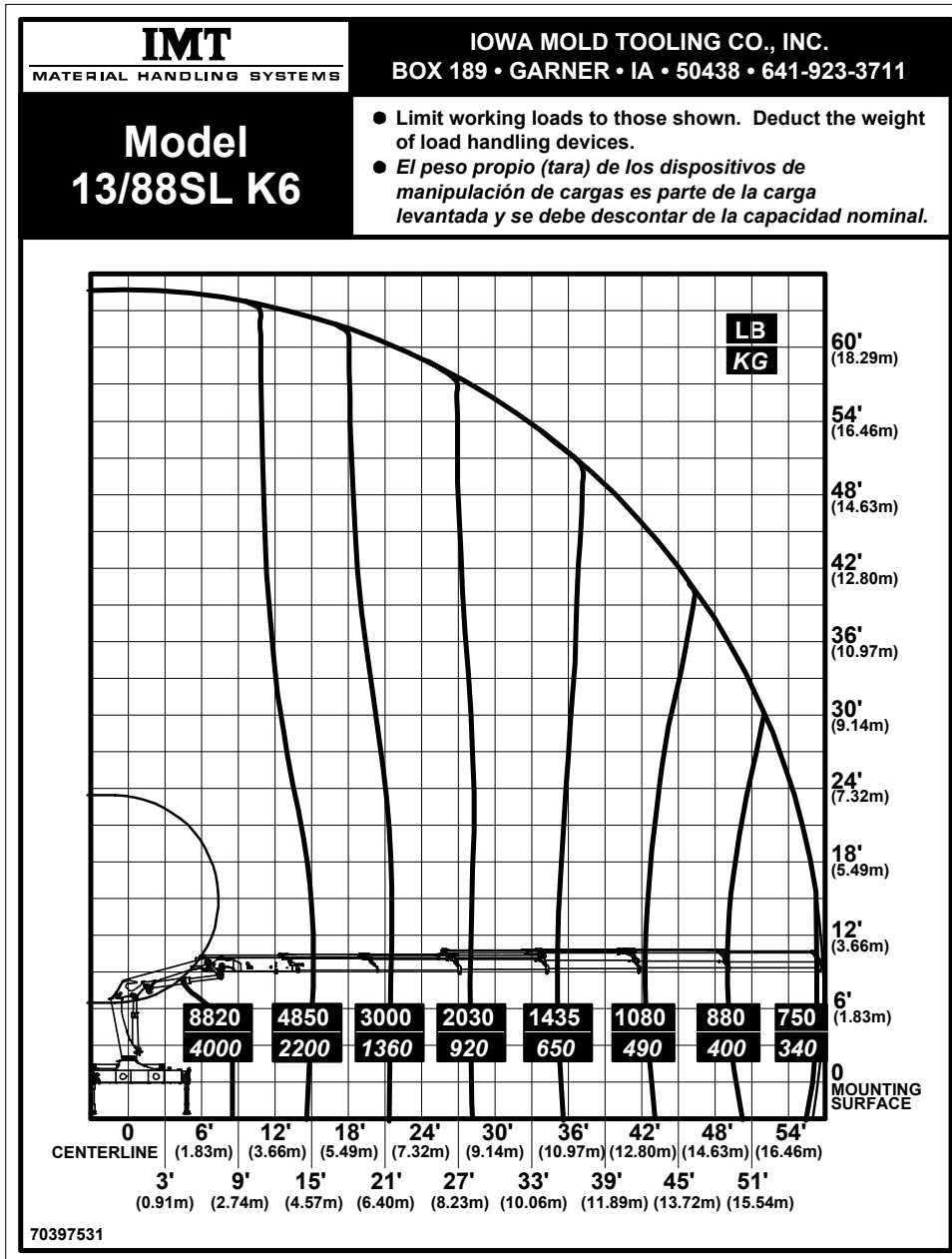

13/88SL Geometric Configuration

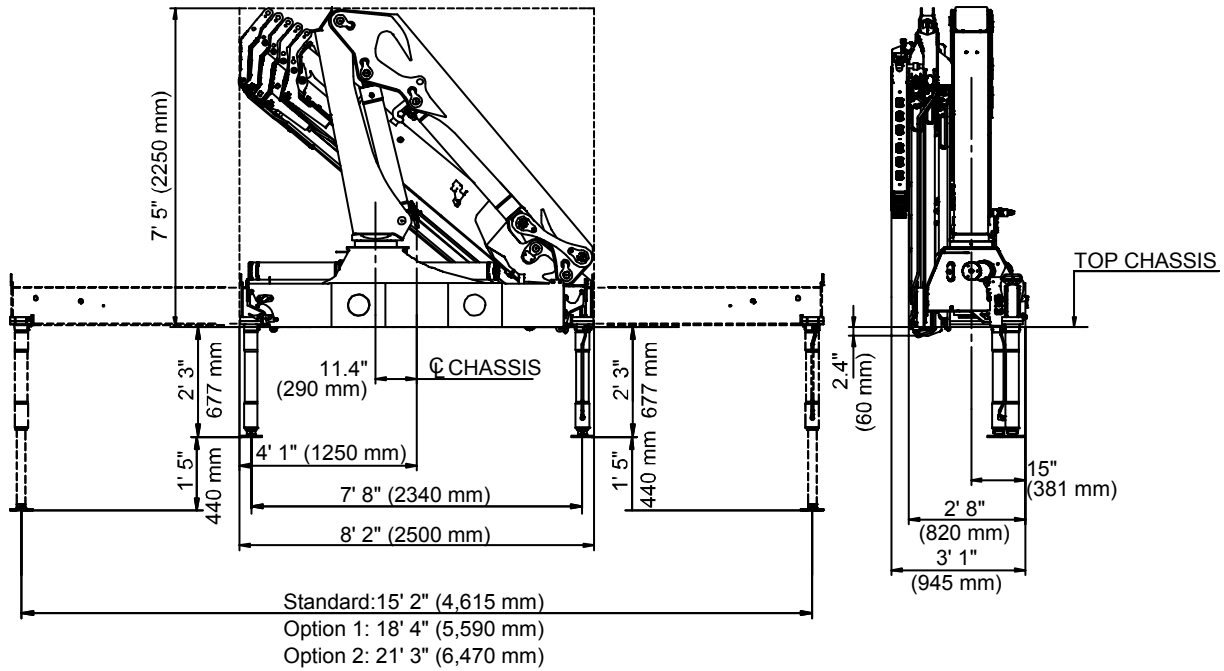
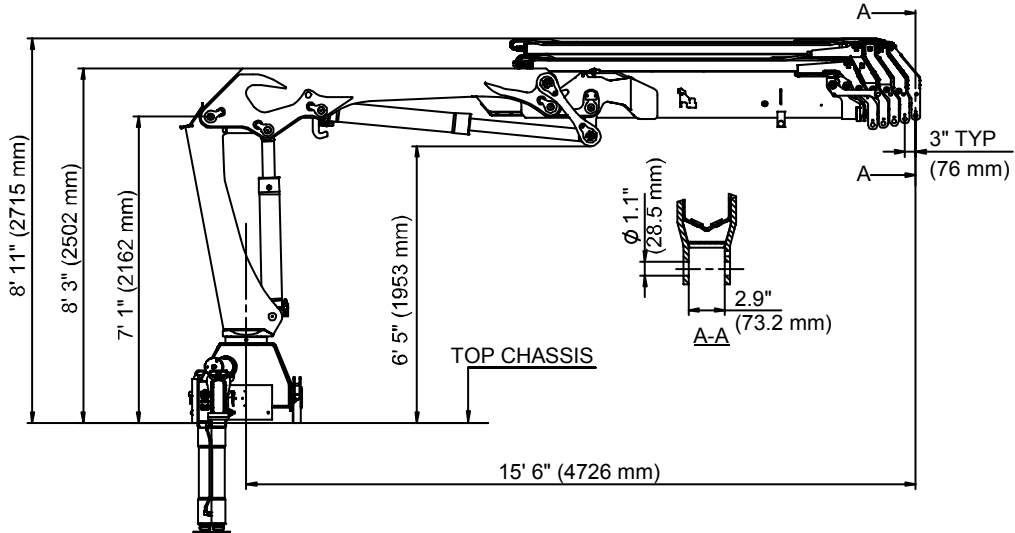

Stabilizer Dimensions, Fixed Legs

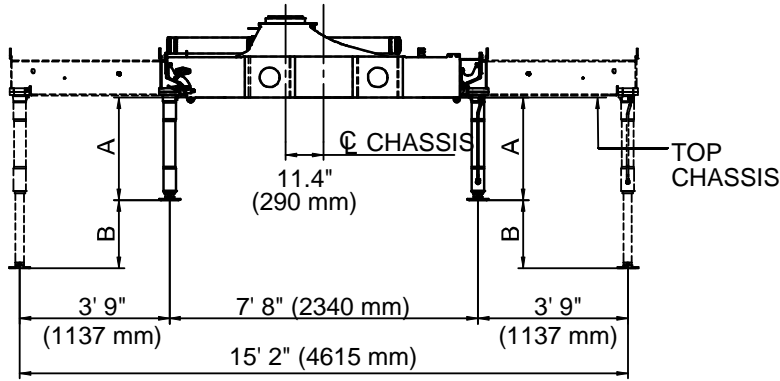



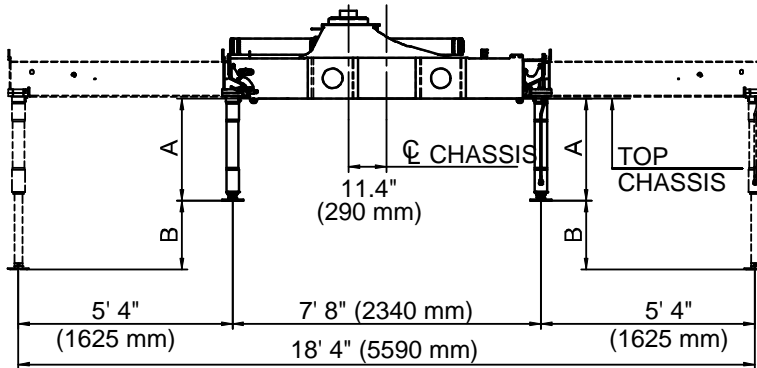

STANDARD

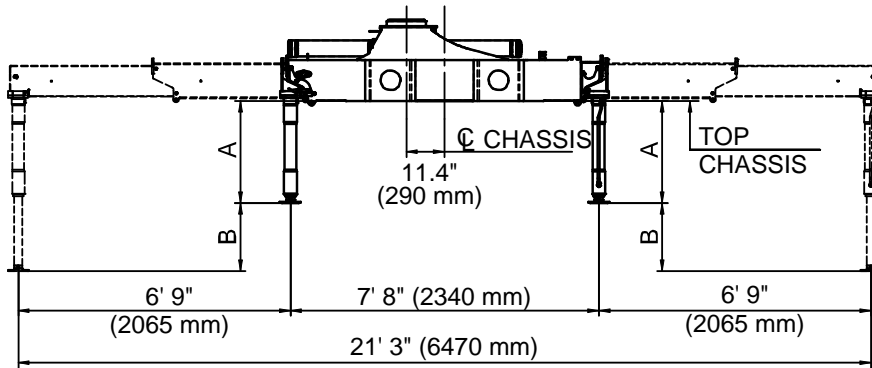

OPTION 1
(Manual Out / Hydraulic Down)





OPTION 2
(Hydraulic Out / Hydraulic Down)

				
A	2' 3" (677 mm)	2' 6" (777 mm)	2' 11" (877 mm)	3' 2" (977 mm)
B	1' 5" (440 mm)	1' 8" (520 mm)	1' 8" (520 mm)	1' 8" (520 mm)

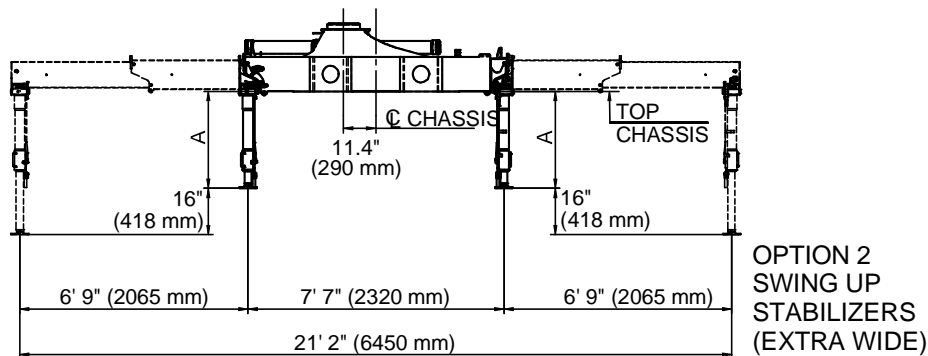
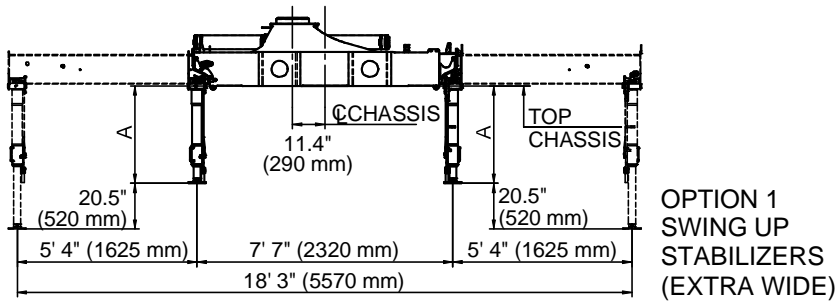
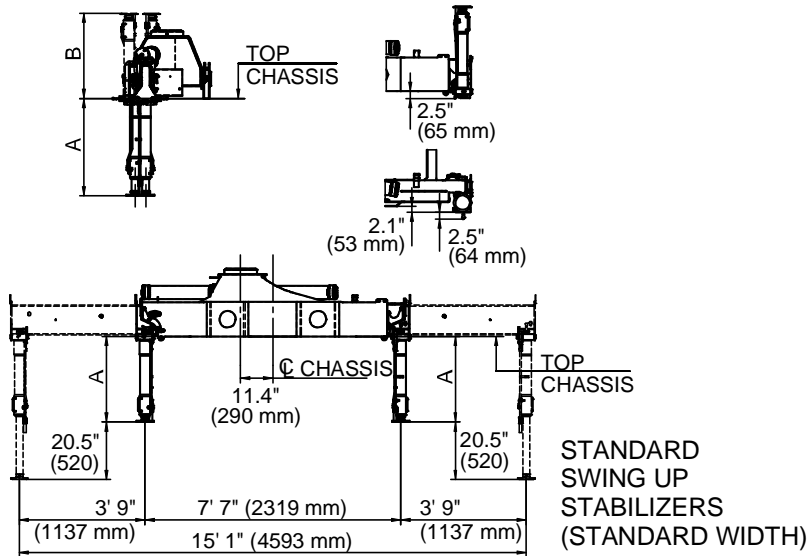
Stabilizer Dimensions, Hyd Swing-Up Legs



			
A	35" (881 mm)	39" (981 mm)	42.5" (1081 mm)
B	30.5" (775 mm)	34.4" (875 mm)	38.4" (975 mm)

13/88SL Swing Clearance

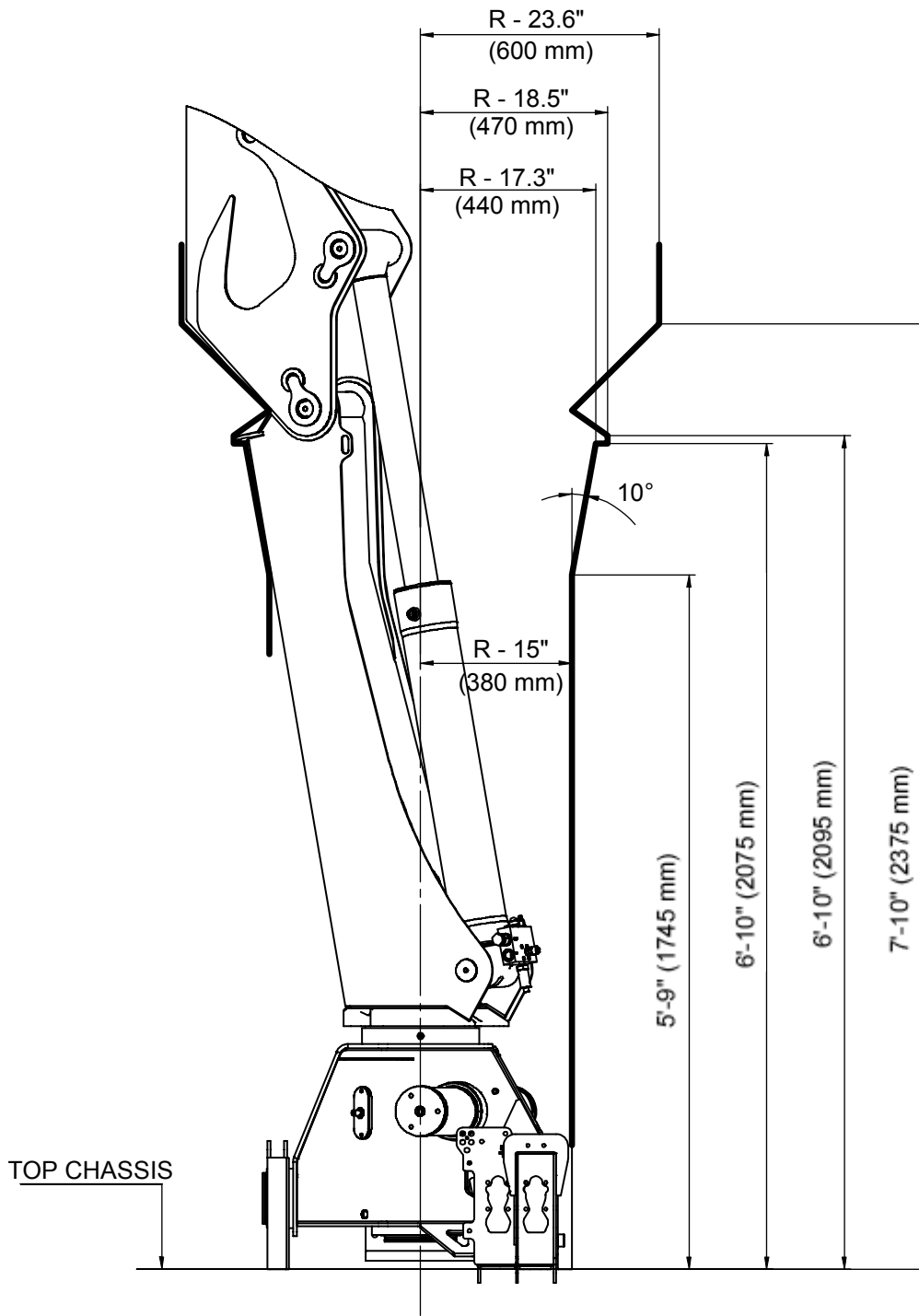

CHAPTER 2

Hydraulic Schematics

In This Chapter

Hydraulic Diagram - 13/88SL Manual Control.....	18
Hydraulic Diagram - 13/88SL Radio Control	19
Hydraulic Diagram- 13/88SL Top Seat Control	20

Hydraulic Diagram - 13/88SL Manual Control

This diagram applies to a 13/88SL crane with a single-circuit fixed pump and 6-function manual controls.

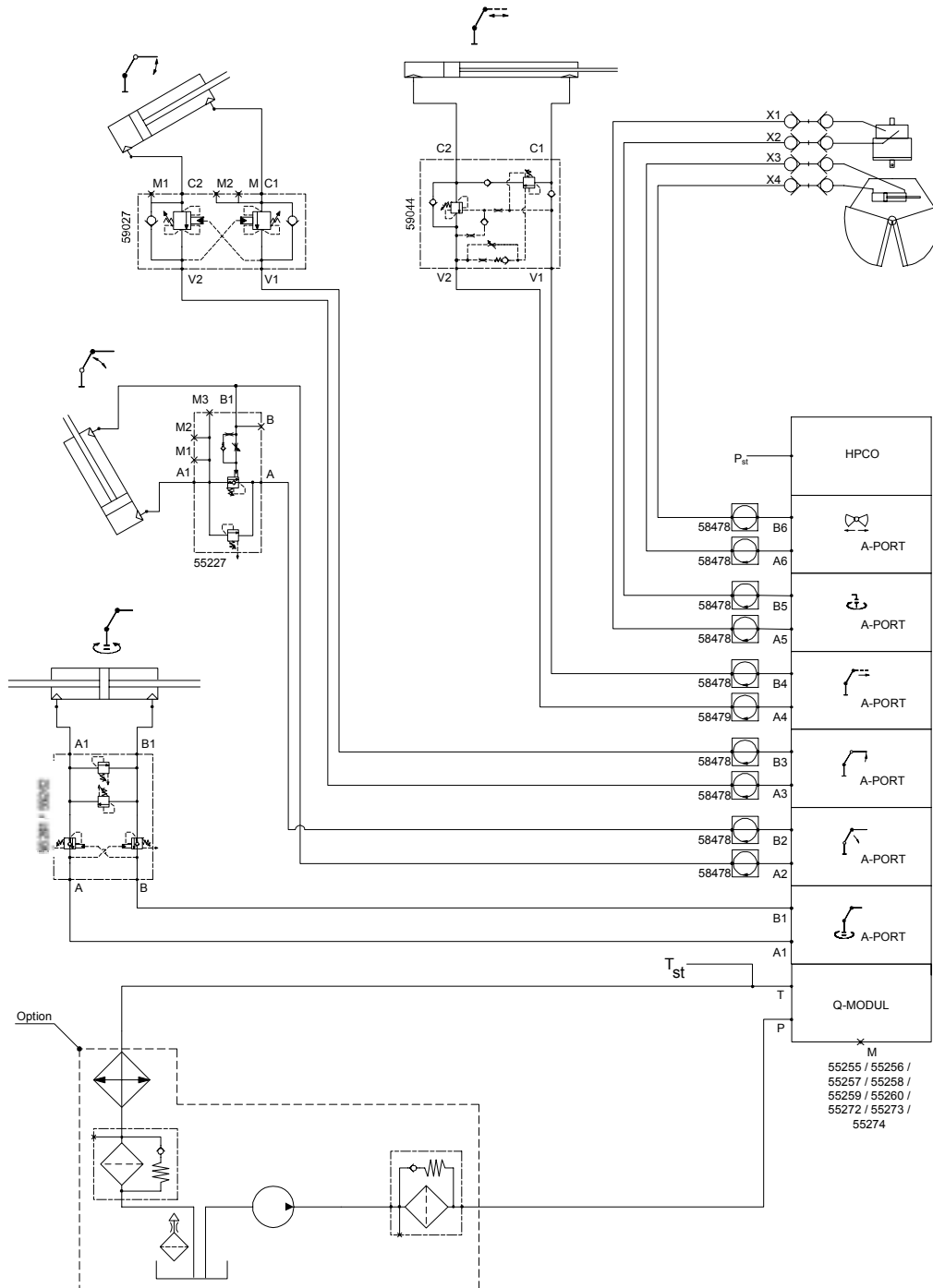

Hydraulic Diagram - 13/88SL Radio Control

This diagram applies to a 13/88SL crane with a single-circuit fixed pump and 6-function radio controls.

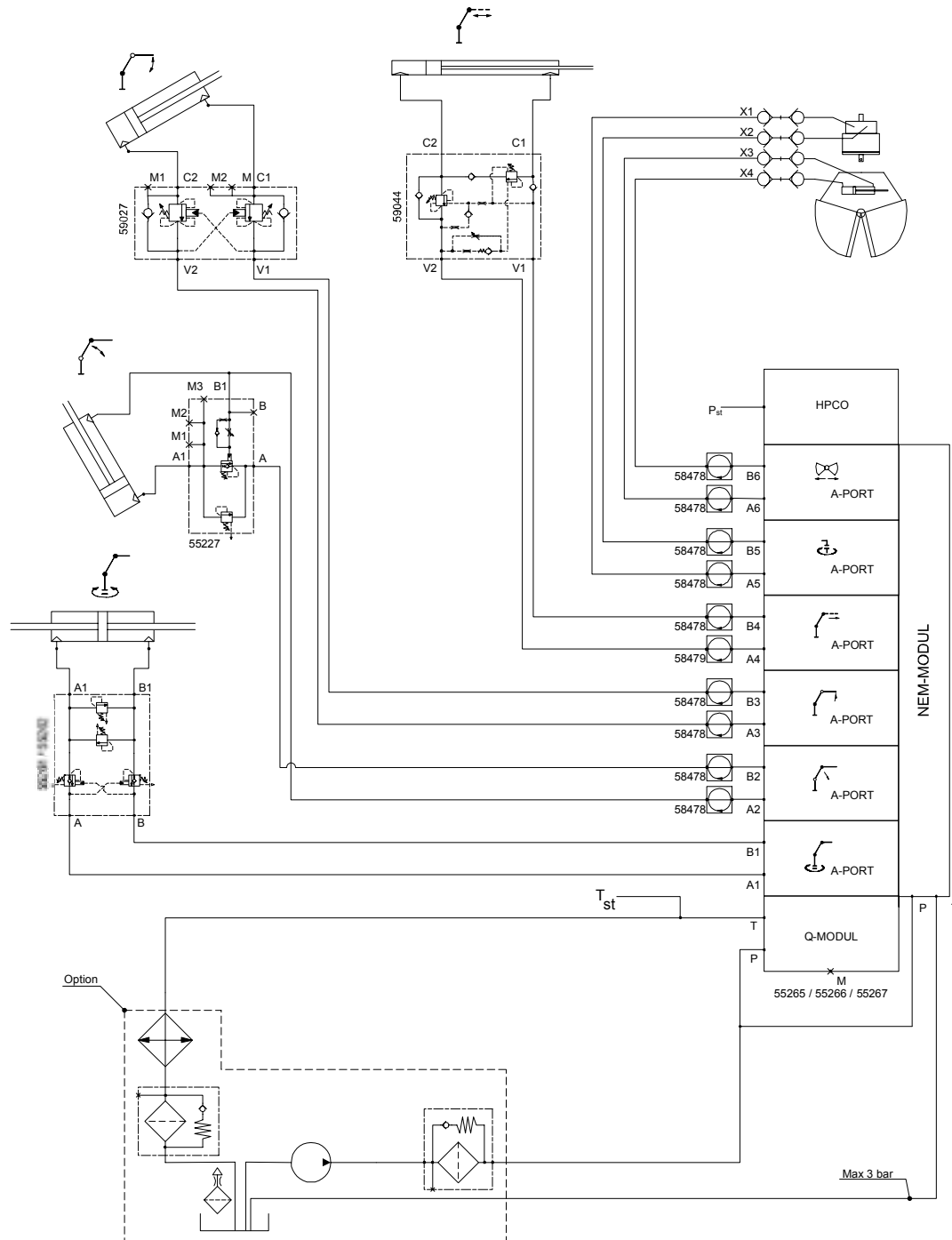

Hydraulic Diagram- 13/88SL Top Seat Control

This diagram applies to a 13/88SL crane with a single-circuit fixed pump and 6-function top seat controls.

