

Shuttlelift Carrydeck Crane 3340B - Specs

3340B

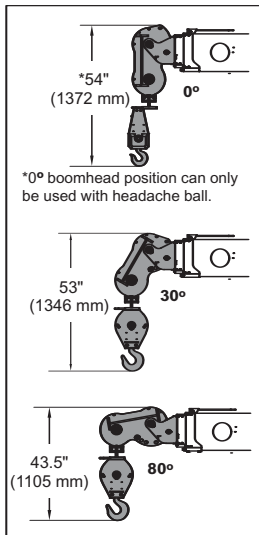

Dimensions are with the boom horizontal and the anti-two block bottomed.

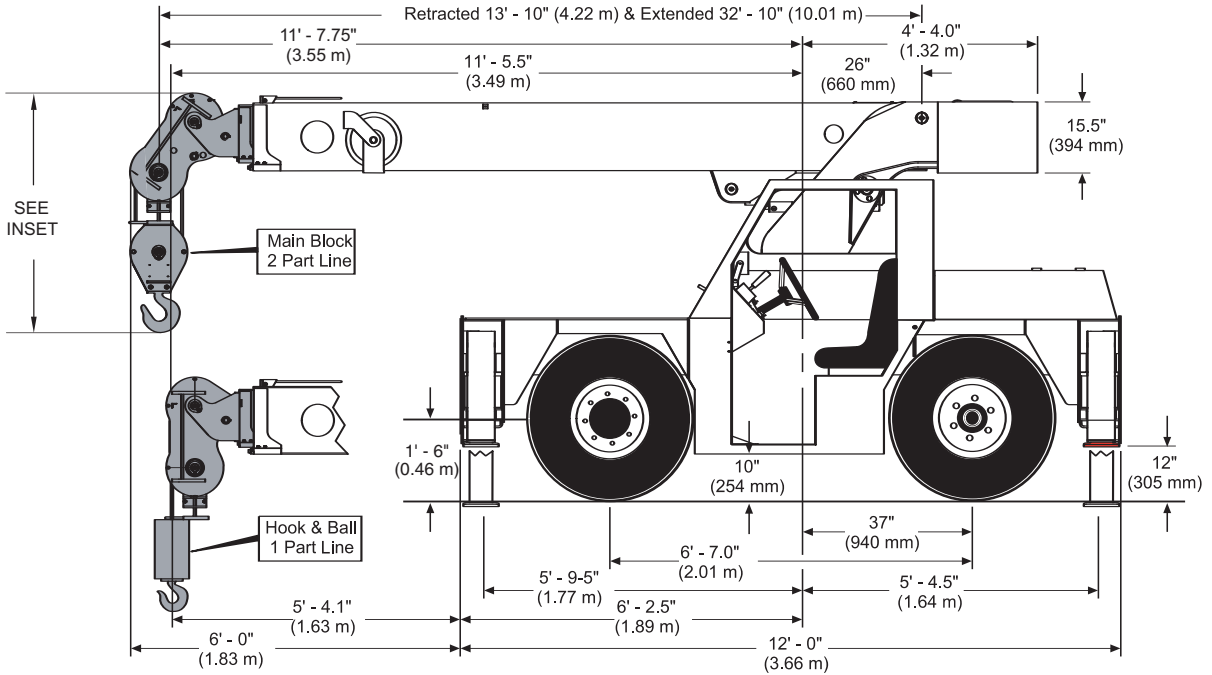
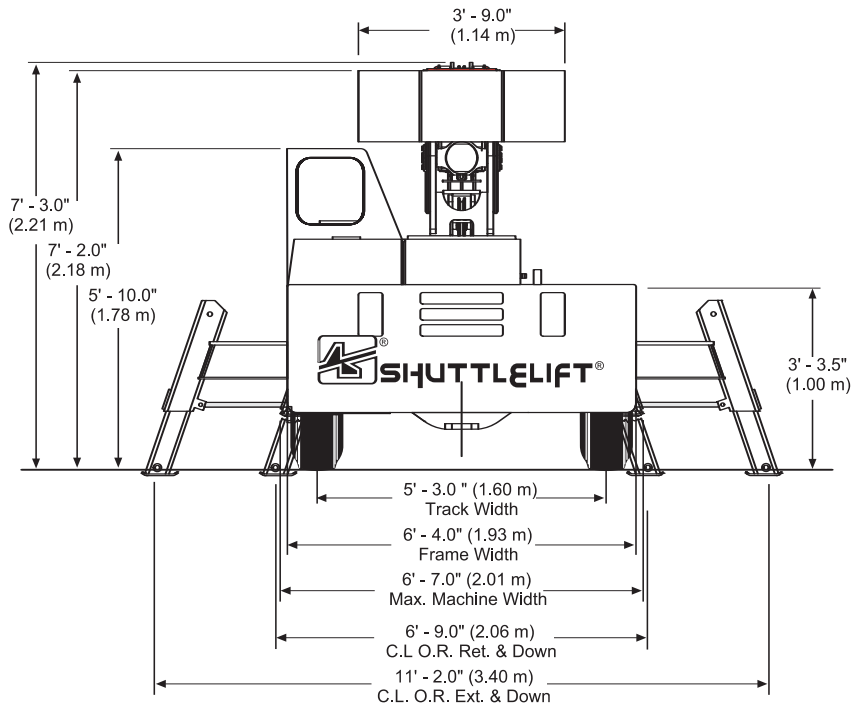

Shuttlelift Carrydeck Crane 3340B - Specs

3340B

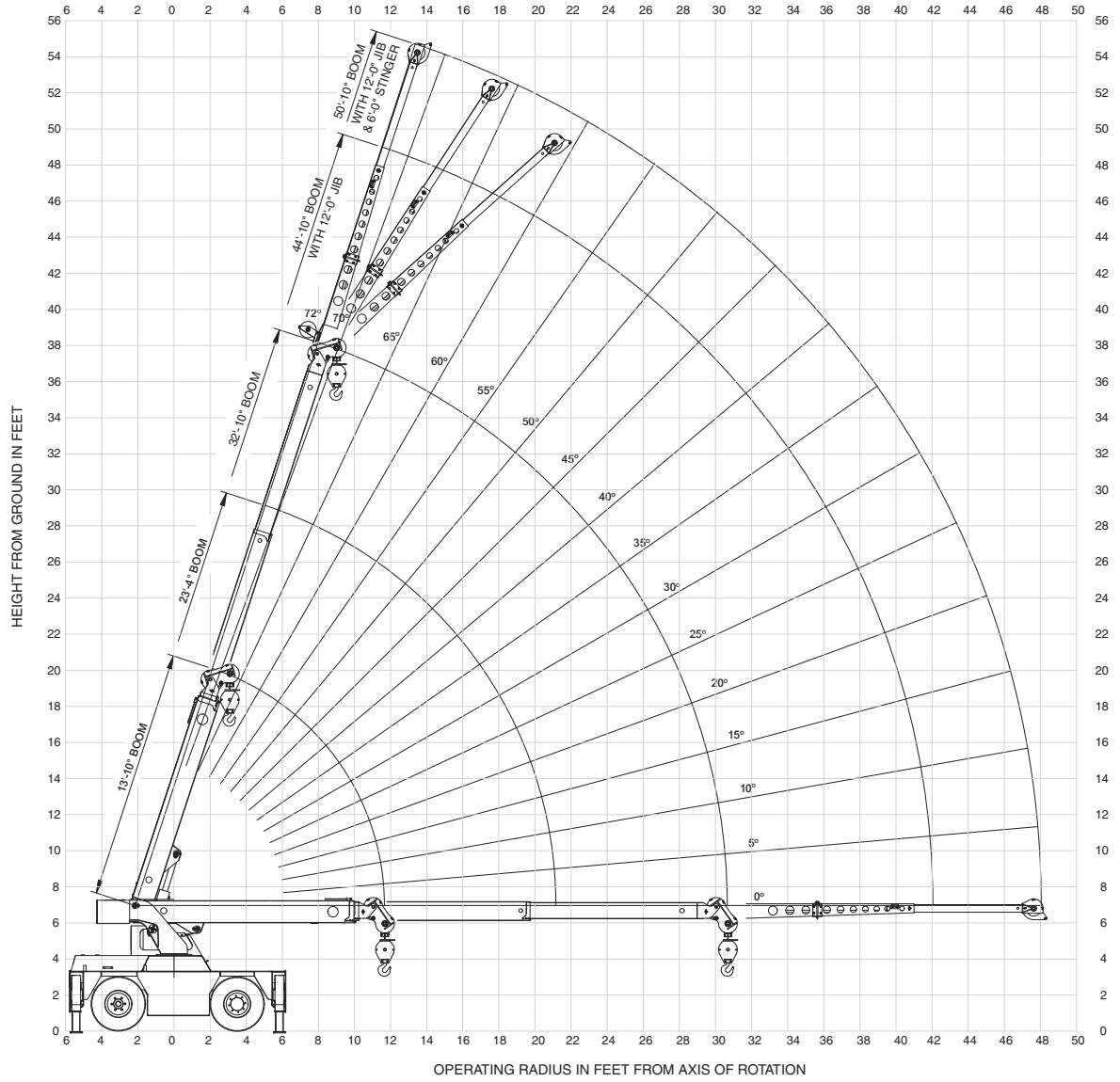

Shuttlelift Carrydeck Crane 3340B - Specs

3340B

	RADIUS (ft)	ON OUTRIGGERS (lbs)				ON RUBBER (lbs)		JIB STRUCTURAL CAPACITIES (lbs)						
		EXTENDED 360° RETRACTED F/R		RETRACTED 360°		F/R	360°	12 FT JIB			18 FT JIB			
		BOOM RETRACTED	BOOM EXTENDED	BOOM RETRACTED	BOOM EXTENDED	ANY BOOM	ANY BOOM	0° OFFSET	15° OFFSET	30° OFFSET	0° OFFSET	15° OFFSET	30° OFFSET	
MAIN BOOM	4.0	21000	15000	21000	15000	11500	11500	72	7500	5100	3500	4000	3300	2300
	5.0	18000	14700	18000	14700	11500	9400	70	7000	4800	3400	3750	3100	2200
	6.0	15700	14400	14400	14400	10000	7800	65	5700	4100	3100	3200	2700	2000
	8.0	12200	12200	9400	9400	8100	5900	60	4500	3500	2800	2800	2400	1850
	10.0	10200	10200	6700	6700	6100	4100	55	3500	3000	2550	2450	2150	1700
	12.0	8400	8400	5000	5000	4600	3000	50	2800	2500	2300	2150	1950	1600
	14.0	-	7100	6700	6700	3600	2400	45	2300	2200	2000	1900	1750	1500
	16.0	-	6000	6700	6700	3100	2000	40	2000	1900	1800	1700	1600	1400
	18.0	-	5000	6700	6700	2600	1600	35	1775	1675	1600	1525	1450	1350
	20.0	-	4300	6700	6700	2100	1200	30	1600	1500	1400	1400	1300	1300
	22.0	-	3700	6700	6700	1800	1050	25	1450	1400	-	1275	1200	-
	24.0	-	3300	6700	6700	1500	950	20	1350	1350	-	1175	1125	-
	26.0	-	2900	6700	6700	1300	800	15	1300	1300	-	1100	1100	-
	28.0	-	2600	6700	6700	1150	700	10	1275	-	-	1050	-	-
	31.0	-	2300	6700	6700	1000	500	5	1225	-	-	1025	-	-
	34.0	-	1975	6700	6700	850	350	0	1200	-	-	1000	-	-
JIB	36.0	-	1775	6700	750	275								
	38.0	-	1575	6700	625	200								
	40.0	-	1425	6700	525	125								
	42.0	-	1300	6700	425	75								
	44.0	-	1200	6700	375	0								
	46.0	-	1100	6700	325	0								
	48.0	-	1000	6700	250	0								

JIB CAPACITY IS LIMITED BY BOTH STRUCTURAL CAPACITY CHART AND MAIN CAPACITY CHART.

OPERATION OF THIS EQUIPMENT IN EXCESS OF RATING CHARTS AND DISREGARD OF INSTRUCTIONS IS DANGEROUS AND VOIDS WARRANTY.

SHADED AREAS ARE GOVERNED BY STRUCTURAL STRENGTH, DO NOT RELY ON TIPPING.

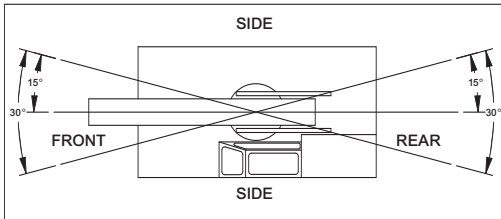

REDUCTION CHART		
	FROM MAIN BOOM RATINGS	FROM JIB RATINGS
MAIN BLOCK	140 lbs	N/A
HOOK & BALL	100 lbs	100 lbs
JIB, STOWED	0 lbs	N/A
JIB, DEPLOYED	450 lbs	0 lbs

RIGGING CHART	
<p>1-PART 0-10000 lbs</p>	<p>2-PART 0-21000 lbs</p>
<p>WIRE ROPE: 9/16 inch diameter Min. breaking strength 36750 lbs.</p>	

- The rated loads are the maximum lift capacities as determined by operating radius, boom extension and boom angle. The operating radius is the horizontal distance from a projection of the axis of rotation to the supporting surface, before loading, to the center of vertical hoist line or tackle with load applied.
- The rated loads shown on outriggers do not exceed 85% of actual tipping. The rated loads shown on rubber do not exceed 75% of actual tipping. These ratings are based on freely suspended loads with the crane leveled, standing on a firm, uniform supporting surface. Practical working loads depend on supporting surface, operating radius and other factors affecting stability. Hazardous surroundings, climatic conditions, experience of personnel and proper training must all be taken into account by the operator.
- The weights of all load handling devices such as hooks, hook blocks, slings, etc., except the hoist rope, shall be considered as part of the load. See reduction chart.
- Ratings on outriggers are for either outriggers fully extended and down or fully retracted and down. Ratings for outriggers fully retracted and down will apply for any intermediate outrigger setting.
- Ratings on rubber depend on tire capacity, condition of tires and proper inflation pressure (100 psi). Loads on rubber may be transported at a maximum speed of 2.5 mph on a smooth hard level surface with boom retracted to the shortest length possible and centered over front.
- For operating radius not shown, use load rating of next larger radius.
- The maximum combined total boom and deck load is 12000 lbs. The maximum deck load only is 14000 lbs.
- Do not induce any external side loads to boom or jib.