

MANTSINEN

160

HybriLift®



More load, less energy.



MANTSINEN 160 HybriLift®

2006

HybriLift® testing and development

2008

200 HybriLift® into production and operation

2010

120 HybriLift® into production and operation

2011

160 HybriLift® into production and operation

2012

70 and 90 HybriLift® into production and operation

The unique HybriLift® energy storage and recovery system improves energy efficiency by up to 35 %.

During each working cycle, energy is stored in hydraulic accumulator system and again recovered to lift the main boom.

Mantsinen HybriLift® system allows using downsized engines and motors with lower emissions.

Mantsinen HybriLift® material handlers and attachments are designed for bulk material and general cargo handling.

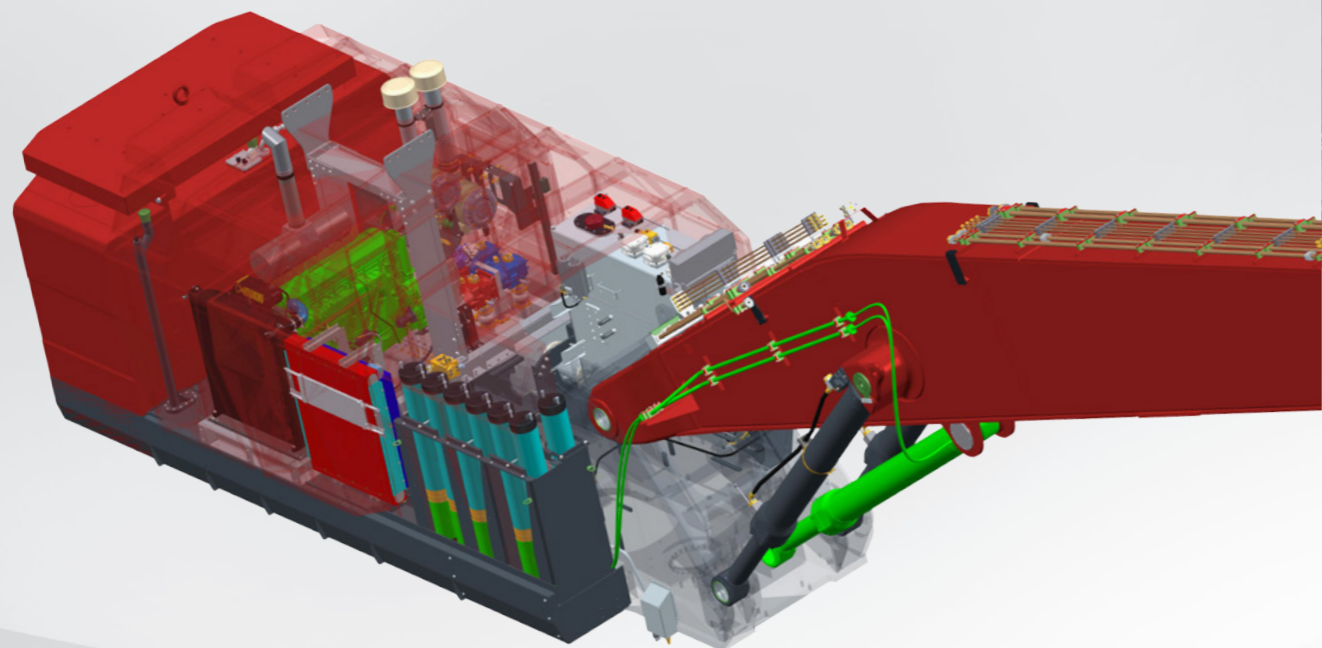

MANTSINEN 160 S / ES



Odense, Denmark

UNDERCARRIAGE

RAIL MOUNTED UNDERCARRIAGE

The configuration of the rail undercarriage can be adapted to existing rails. High gantry versions allow one or two railroad wagons to pass through the machine. Cable reels are available to meet requirements of drive distance and speed.

BOGIES

Mantsinen160 ES is available with 4 of 6 wheel bogies according to rail and quay carrying capacities. The distance between the bogies can also be chosen according to application.

WHEELS

Wheel diameter can be optimized to match the loads of the machine and bogie design. There are 400 mm and 630 mm wheels available.

ELECTRIC MOTOR

Electric motor is mounted in a container unit, making easily accessible from both sides. The sound isolated compartment keeps noise at minimum. Hydraulic pumps are isolated from the motor by a firewall.

Lower operating and maintenance costs ensure shorter pay-pack time on investment, while noise and particulate emissions decrease considerably. Electric power also reduces noise and eliminates particulate emissions.



MANTSINEN 160

STICK FOOT & TIP

Stick foot and tip are made of high-tensile cast steel. The extensive use of cast structures in the front equipment is the backbone of its durability.

STICK BOX

The box of the stick is made of two C-profiles using fine-grain steel. This design eliminates welding seams in high stress areas and provides an extremely strong, light and durable structure. Hydraulic lines are well protected on sides of the stick.

MAIN BOOM BOSSES

Also the bosses at the main boom are made of high-tensile cast steel. The optimized design ensures evenly distributed stresses on the boom box.

MAIN BOOM FOOT

Main boom foot is made of cast steel. This provides an extended service life to one of the most stressed structural components of the machine. The double steel plates of the upperstructure frame run all the way from front equipment pivot points to the counterweight making the frame extremely rigid.

ENGINE AND PUMPS

The engine and hydraulic pumps are accessible from both sides. The sound insulated compartment keeps engine and pump noise at a minimum.

RADIATOR

Side by side mounted radiator and hydraulic oil cooler provide easy access and cleaning. Fan reversing function helps to keep the coolers clean also in dusty environments.

SERVICE WALKWAYS

The wide inside and outside service walkways provide an unprecedented access to all service points. A wide doorway leads to the interior compartments of the upperstructure.

UNDERCARRIAGE

The gantry type undercarriage allows trucks or wagons to pass through. It is available in different heights. One or two additional fuel tanks are available as an option.

TRACKS

The long undercarriage is stable and durable and allows 360 degree lifting of rated loads on firm and level underfoot conditions.

TRACK SHOES

The Mantsinen designed flat track shoes run smoothly on gravel, asphalt and concrete surfaces.

CAB ELEVATOR

Mantsinen cab elevator brings the operator high up or far from the swing centre, on top of the hold, depending on the working environment. The spacious stainless steel operator cab has large windows for an excellent visibility. The floor window is in a 15° angle. The cab is also equipped with an instructor seat.

SWING MECHANISM

The Mantsinen 160 swing mechanism consists of two swing motors and a heavy-duty two-row ball type slewing ring with 2,7 m diameter. The internal teeth run in grease bath. The swing mechanism has a separate closed loop circuit pump providing an extremely smooth, precise and controllable swing function. This system provides a remarkable efficiency improvement over previous open loop systems.

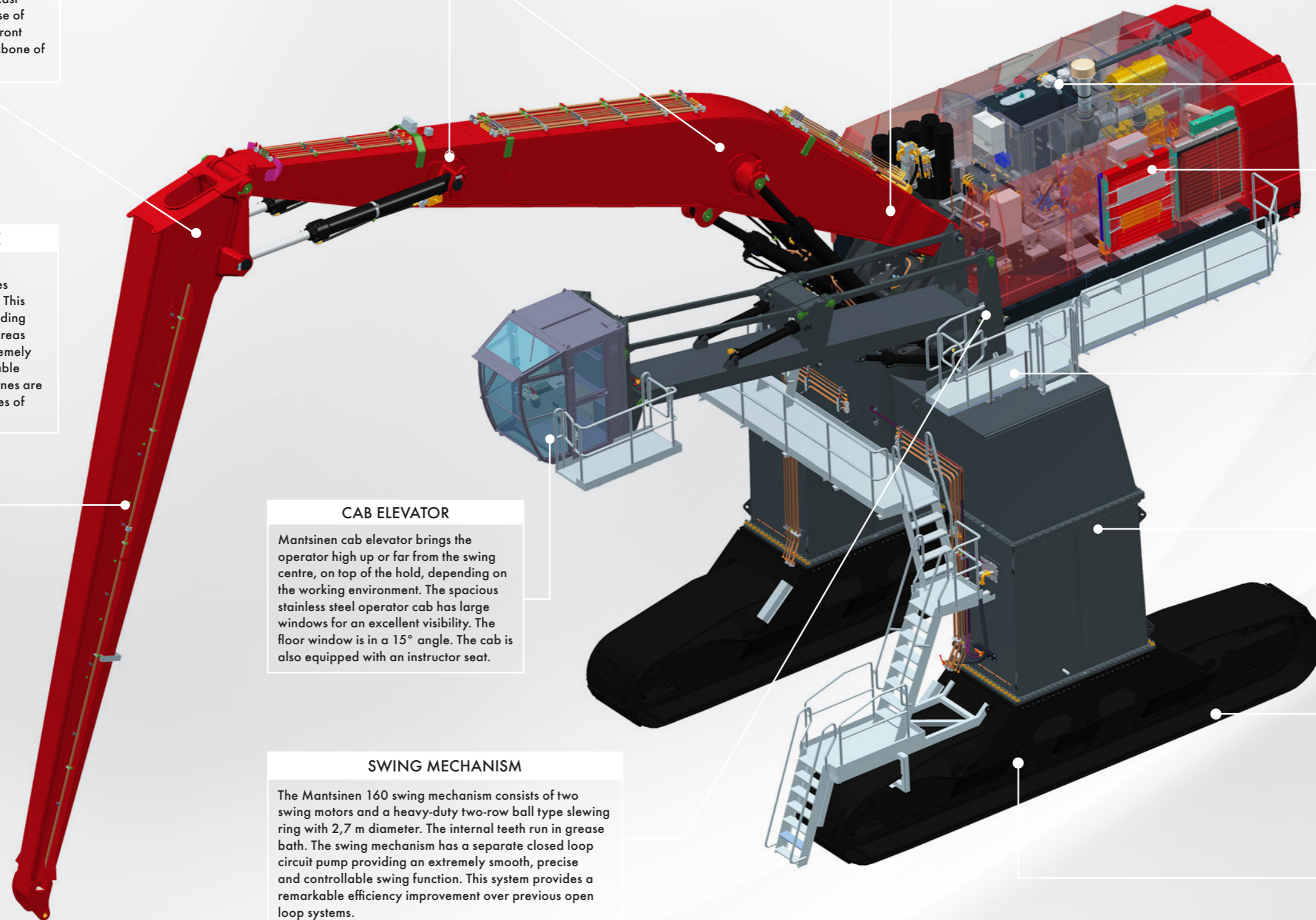

MANTSINEN

TECHNICAL SPECIFICATIONS

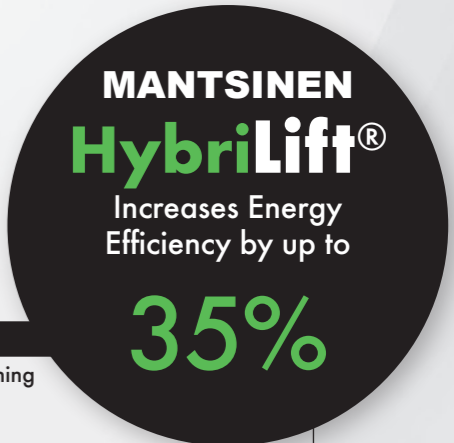

Front equipment	
Max. horizontal reach	31,3 m
Main boom lengths, straight and curved	10,5 / 12,5 / 14,5 / 15,5 / 16,5 / 17,5 m
Stick lengths	9 / 10 / 12 / 13 / 14 / 15 m
Diesel Engine	
Diesel Stage II/Tier2	Volvo TAD1643VE 565 kW /1800 r/min
Diesel Stage IV/Tier 4 Final as option	Volvo TAD1672VE 515 kW /1800 r/min.
Displacement	16,1 l
Number of cylinders	6
Voltage	24 V
Batteries	2 x 220 Ah / 12V
Electric motor with soft starter	
Motor type	355 kW IEC cast iron motor 1500 rpm / 50 Hz or 1800 rpm / 60 Hz
Voltages	380 to 690 V as standard. Other voltages upon request
Hydraulic system	
HybriLift® energy recovery system	Up to 200 kW equivalent to engine power
Oil flow, equipment and drive	3x 420 l/min
Operating pressure	330 bar
Operating pressure, drive and Heavy Lift mode	350 bar
Oil flow swing closed loop system	540 l/min
Swing pressure, max.	300 bar
Max. swing speed	5,3 r/min
Swing torque	360 kNm
Undercarriage with rubber tyres 160 M / 160 EM	
Weight without attachments	170 to 200 t depending on configuration
Heights	3,8 m as standard. 5,3 / 6,0 / 6,5 m with pylon
Axles	4 heavy duty steering axels, two hydraulically driven
Tyres	16 pcs 16.00-25 solid rubber
Service brakes	Wet multidisc brakes
Parking brake	Spring applied wet multidisc brakes
Drive speed	Max 4 km/h
Stabilizer pads	2 000 x 2 500 mm.
Undercarriage with tracks 160 R / 160 ER	
Weight without attachments	160 to 200 t depending on configuration
Heights	1,6 and 3,0 m as standard. 4,8 / 5,5 / 6,0 m with pylon
Gantry:	6,9 / 7,6 / 9,0 m and 10,5 m with pylon
Load carrying track length	7 140 mm
Track shoes	1 000 mm
Travel speed	3,0 km/h
	HD-tracks available for gantry
Undercarriage mounted on rails 160 S / 160 ES	
	According to customer specification.
Undercarriage, fixed 160 F / 160 EF	
	According to customer specification.
Hydraulic oil reservoir	1 650 l
Fuel tank	2 800 l

Operator's cabin	
<ul style="list-style-type: none"> • Large crane cabin with an instructor seat • Ergonomic air-cushioned seat <ul style="list-style-type: none"> - Adjustable armrests - Seat belt and seat heating - Adjustable lumbar support - Adjustable headrest 	<ul style="list-style-type: none"> • Heating and air conditioning • Floor and roof window • Tinted window glasses • Windshield wiper with intermittent function, washer • Roof window wiper • Sun shades • Radio with CD, MP3-compatible
Mantsinen Control System	
<ul style="list-style-type: none"> • Ergonomic, adjustable multi-function joysticks • Drive and steering by one grip joystick • All front equipment and attachment functions proportional • Function speeds and ramps adjustable • Electric end cushion boom, stick and cab elevator • Precision mode • Heavy lift mode 	<ul style="list-style-type: none"> • Colour display 5.7" user interface <ul style="list-style-type: none"> - Operating data and gauges - Warning signals, illuminated pop up type symbols - Acoustic signal for critical alarms - Settings - Diagnostics - Log function - Instant power consumption - Periodic fuel or electric power consumption
Mantsinen Safety System	
<ul style="list-style-type: none"> • Overload and stability control with motion cut • Cab collision prevention with motion cut • Adjustable operation limitations • Can Open CAN-bus technology 	<ul style="list-style-type: none"> • Colour display 5.7" user interface <ul style="list-style-type: none"> - Animated machine operation - Load, reach and height information - Attachment menu
Standard equipment	
<ul style="list-style-type: none"> • Load control valves on boom and stick cylinders including hose rupture valves • Thermostat controlled hydraulic fans • Capable full flow filters • By-pass fine filter 3 µm with water absorption • Second pressure adjustment for attachments 	<ul style="list-style-type: none"> • Central lubrication system for front equipment and slew bearing • Working lights, 4 underneath the cabin and 4 on stick • Acoustic travel alarm • Signal horn • Service platforms
Options	
<ul style="list-style-type: none"> • Fixed cab positions • Cab elevator N1-3000 • Cab elevator N2-5000 • Cab elevator N2-6000 • Operator seat BE-GE 3000 SE <ul style="list-style-type: none"> - Airvent function - Air-cushioned - Centralized control panel • Xenon or LED working lights • Camera under stick • Rear view camera • Beacon light travel alarm • Loudspeaker • Mantsinen Control System remote access • Automatic clamshell bucket levelling while closing 	<ul style="list-style-type: none"> • Biodegradable hydraulic oil • Large by-pass fine filter with water absorption • Second hydraulic function for attachment • Engine preheating • Hydraulic oil preheating • Cab preheating • Bullet proof windshield • Magnet generator 20 kW or 30 kW • Additional fuel tanks, depending on configuration • Electric re-fuelling pump

Specifications subject to change without prior notice. The photographs and/or drawings in this brochure are for illustrative purposes only. Refer to the Operator's Manual for instructions on the proper use of this equipment.

MANTSINEN 160 IN ACTION

For more information, images
and videos visit our website
mantsinen.com



Lifting capacity range - 10,5 m curved + 9,0 m

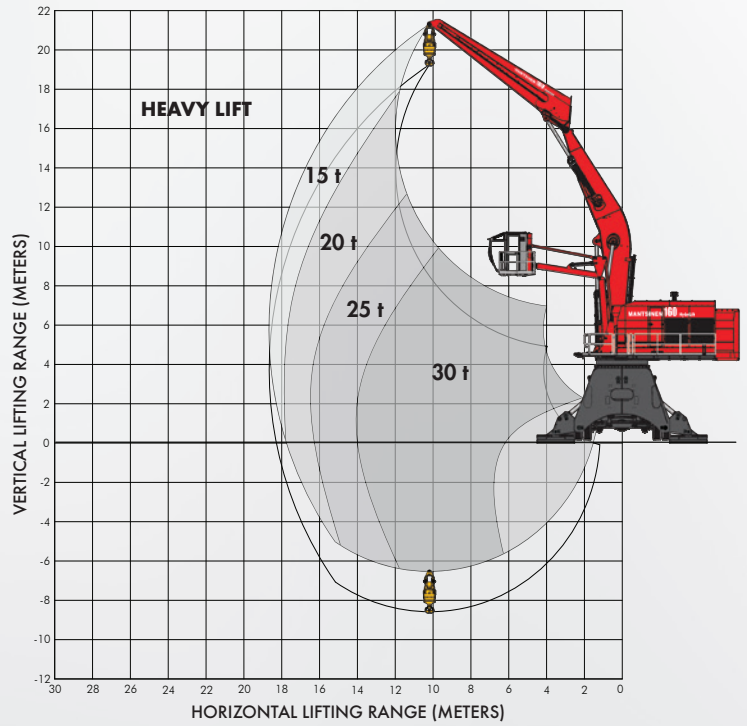

Lifting capacity range - 16,5 m curved + 14,0 m

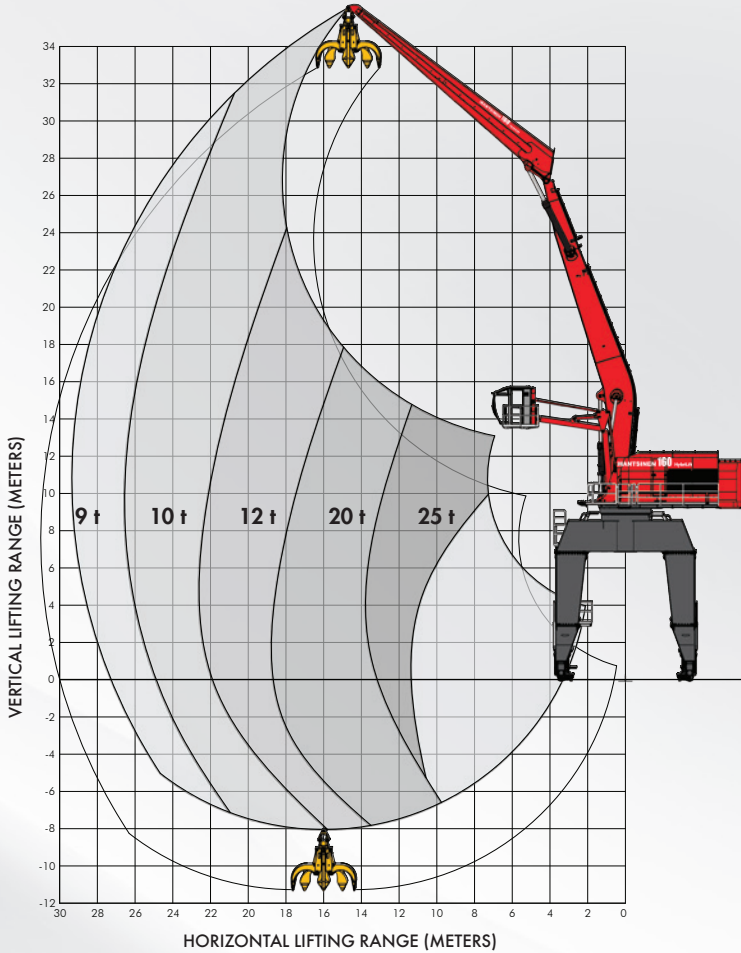

Lifting capacity range - 15,5 m curved + 13,0 m

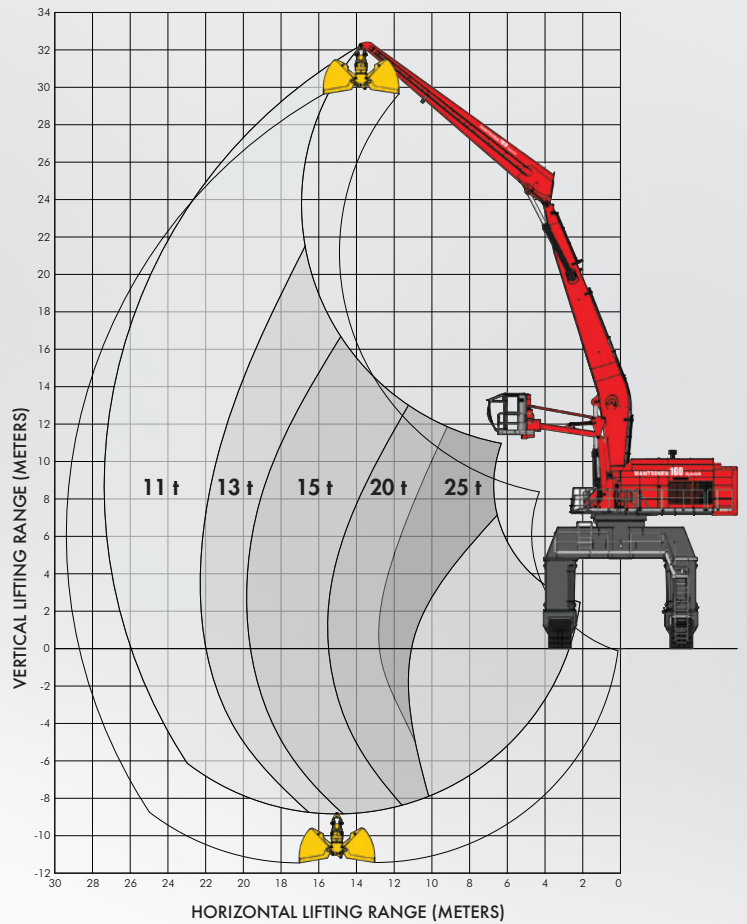

YOUR DEALER:

**ISO 9001
ISO 14001
OHSAS 18001**

We are committed to improve our integrated operational system continuously. We take care of environment and health&safety issues in all our operations.



Mantsinen Group Ltd Oy Väläkankaantie 3, FI-80400 Ylämylly, FINLAND
Tel. +358 20 755 1230 | info@mantsinen.com | www.mantsinen.com