

LIFTMOORE 72100 CRANE

72,000 FT.-LB. MOMENT RATING
10,000 LB. MAXIMUM CAPACITY

Liftmoore's 72100 is the largest capacity crane we produce. Moment rating of the crane is 72,000 ft.-lbs. with a maximum lifting capacity of 10,000 lbs. at a 7.2 ft load radius.

360 degrees unlimited rotation is standard on the 72100. Rotation is powered through a 45:1 ratio worm gearbox with a bronze worm gear for positive locking and smoothest operation. The crane rotates on a gear bearing slewing ring with external teeth for best strength.

Wireless FM Radio Proportional control is standard complete with a "tethered Can Wire".

Two Basic Models to choose from

- **72100XP-24** Full Power extension from 11 Ft to 24 Ft
- **72100XP-30** Full Power extension from 15 Ft to 30 Ft

The 72100 meets the manufacturing requirements of OSHA standard 29CFR 1910.180 including the required strain gage analysis.

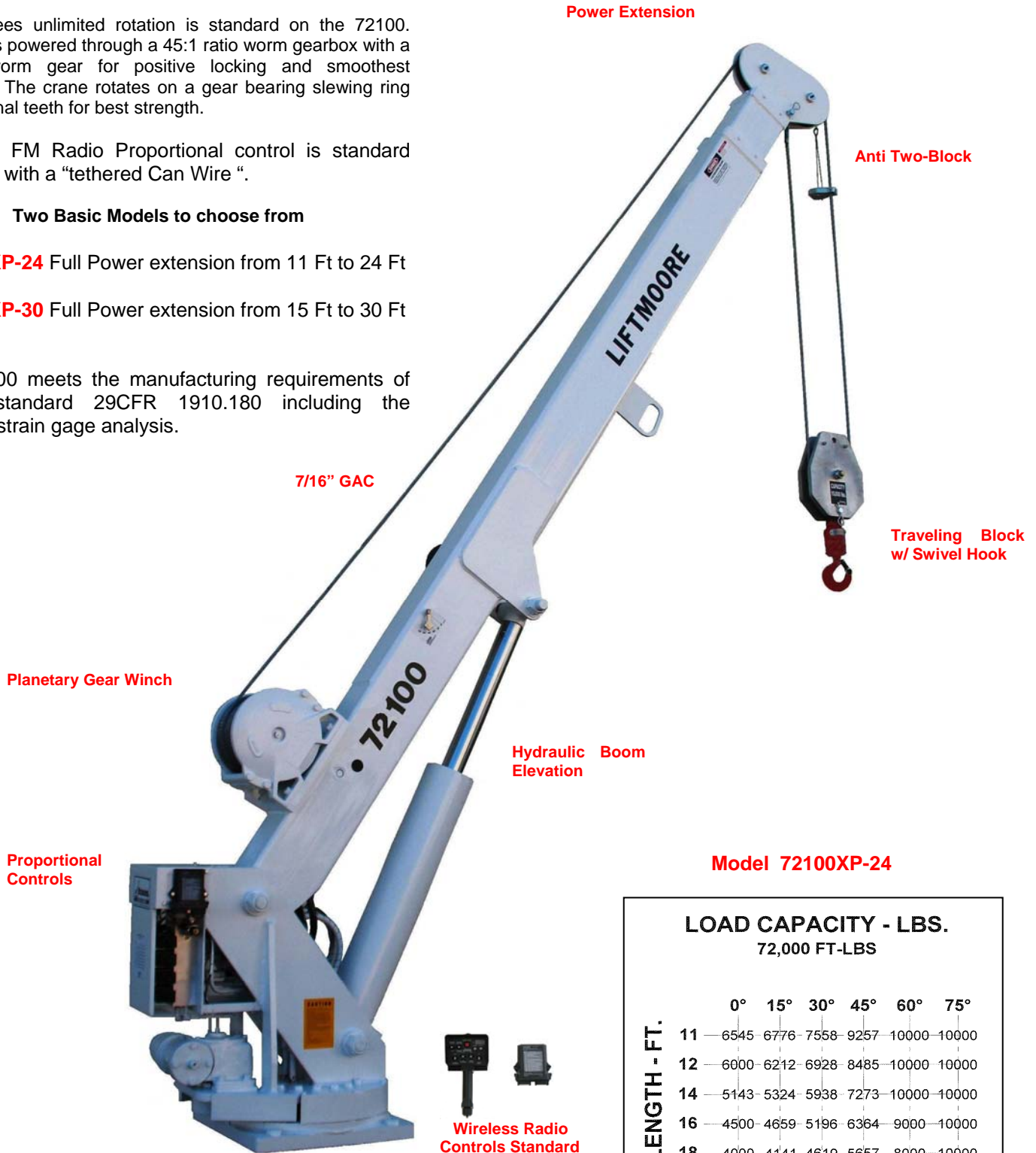

Planetary Gear Winch

Proportional Controls

Hydraulic Boom Elevation

Model 72100XP-24



360° Unlimited Rotation,
External Gear Bearing

LOAD CAPACITY - LBS. 72,000 FT-LBS

BOOM LENGTH - FT.	LOAD CAPACITY - LBS.					
	0°	15°	30°	45°	60°	75°
11	6545	6776	7558	9257	10000	10000
12	6000	6212	6928	8485	10000	10000
14	5143	5324	5938	7273	10000	10000
16	4500	4659	5196	6364	9000	10000
18	4000	4141	4619	5657	8000	10000
20	3600	3727	4157	5091	7200	10000
22	3273	3388	3779	4628	6545	10000
24	3000	3106	3464	4243	6000	10000



HOUSTON, TEXAS
FAX: (800) 824-5559 (USA & Canada)
FAX: (713) 688-6324
PHONE: (713) 688-5533
www.liftmoore.com

713-688-5533
WWW.LIFTMOORE.COM

72100 SPECIFICATIONS

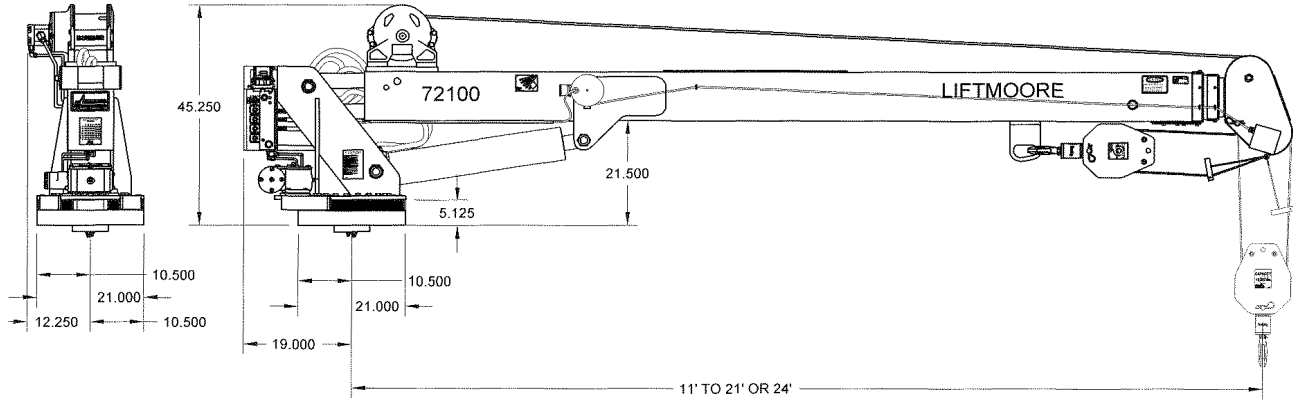

MOMENT RATING:

72,000 Ft.-Lbs.

HOIST WINCH:

A planetary gear drive hoist is included. This is the most efficient method of powering the winch. Single line no load speed of the winch is 35 feet per minute with a 6 GPM flow rate. Winch drum to wire line ratio meets ANSI B30.5 requirements.

10,000 Lbs. @ 7.2 ft **	5,142 Lbs. @ 14 ft. **
7,200 Lbs. @ 10 ft. **	4,000 Lbs. @ 18 ft.
6,000 Lbs. @ 12 ft.	3,000 Lbs. @ 24 ft.

** Two part line required for loads above 5000Lbs.

WIRE ROPE and SHEAVES:

The crane is supplied with 100 Ft. of 7/16 In. galvanized aircraft cable. Minimum breaking strength of the rope is 17,600 lbs. The wire rope is outside of the boom and visible for operator's continual inspection. A 5-ton travel block for easy two-part hookup is included. The hook includes an easy turning roller thrust bearing. All sheaves meet ANSI requirements.

BOOM:

The boom angle varies from -5 to +75 Degrees. Both the elevation and extension cylinders include an integrally mounted counterbalance valve for positive load holding. The boom extends on Nylatron slide pads for minimum friction.

72100XP-24: Power extension from 11 ft. to 24 ft. with a two stage Hydraulic cylinder.

72100XP-30: Power extension from 15 ft. to 30 ft. with a two stage Hydraulic cylinder.

ROTATION:

A ball bearing slewing ring is used for crane rotation. The ring has an external gear for greatest possible strength. The rotation gearbox is powered by a low speed, high torque hydraulic motor, which drives the 13,000 In-Lb rated bronze worm gear box providing a smooth, safe rotation mechanism. The gearbox uses roller bearings on all shafts for the longest possible trouble free life. The crane rotates continuously and with out restriction

RADIO REMOTE CONTROL:

FM radio remote control is standard equipment on the 72100. This digital control includes the proportional controller for hydraulic flow control and monitors the load sensor and anti two-block systems. Includes a system to reduce boom "bounce" during boom down operation. No mechanical relays are used with this control system. A battery charger is included.

HYDRAULIC SYSTEM:

Proportional hydraulic control is standard on the 72100. The system provides variable speed control of all crane functions with the remote control. For smooth operation and minimum heat buildup a pressure compensated flow control system is used. A series control circuit is used so that more than one function will operate simultaneously until maximum pressure is reached.

POWER SOURCE:

The crane requires both Hydraulic and 12 VDC electric power. Hydraulic flow and pressure requirements are 8 GPM and 2750 PSI. An on-off switch, fuse and 25 ft of 10 gauge wire are supplied for standard truck installation.

ENGINE CONTROLS (OPTIONAL):

Engine start, stop and speed control can be included with the remote control. A separate receiver is used in conjunction with the FM controls so that unrestricted rotation is maintained. Truck must be equipped for remote operation

LOAD SENSOR

A load-limiting sensor is installed in the elevation cylinder. This sensor will shut down hoist up, boom out & boom down when an overload is detected. The sensor will rest after the load is lowered.

ANTI TWO-BLOCK:

The anti two-block is standard on this crane & prevents extending the boom against the travel block with possible breakage of the cable

MOUNTING: A minimum 30,000 Lb. GVWR recommended.

Four 1-1/4" Grade 8 bolts are required. Bolts are not furnished. The crane mounts on a 21" square base plate with a 15.5 in. X 18.5 in. bolt pattern.

ACCESSORIES:

An outrigger is needed for stability requirements of OSHA 1910.180. A boom rest is also required. Liftmoore offers both as options.



HOUSTON, TEXAS
 FAX: (800) 824-5559 (USA & Canada)
 FAX: (713) 688-6324
 PHONE: (713) 688-5533
 www.liftmoore.com

Bulletin 452-B 12/30/13