

5/33

Articulating Crane



► 5/33 Articulating Crane

Ideal for virtually any project in a variety of industries, IMT® 5/33 articulating cranes offer greater maneuverability and easy access to tight spots. They have a max capacity of 2975 lb (1350 kg) and a max horizontal reach of more than 31 ft (9.6 m) for a superior lift-to-weight ratio, as well as hexagonal booms for greater strength and stability. Plus, 5/33 articulating cranes can stow within themselves, freeing up payload space for additional materials, and making them the perfect crane for challenging job sites.



5/33 Specifications

	1 - Hydraulic	2 - Hydraulic	3 - Hydraulic	4 - Hydraulic
Crane Rating*	32,550 ft-lb (4.5 tm)	31,825 ft-lb (4.4 tm)	30,380 ft-lb (4.2 tm)	29,655 ft-lb (4.1 tm)
Max Horizontal Reach	16' 1" (4.9 m)	21' (6.4 m)	26' 3" (8 m)	31' 6" (9.6 m)
Max Vertical Reach	23' (7 m)	27' 11" (8.5 m)	32' 9" (10 m)	37' 7" (11.5 m)
Max Capacity	2975 lb (1350 kg)	2820 lb (1280 kg)	2645 lb (1200 kg)	2515 lb (1140 kg)
Max Cap @ Max Reach	2070 lb (940 kg)	1475 lb (670 kg)	1100 lb (500 kg)	825 lb (375 kg)
Crane Weight **	1255 lb (569 kg)	1375 lb (624 kg)	1475 lb (669 kg)	1555 lb (705 kg)
Hook Approach				
Vertical	7' 1" (2.16 m)	6' 9" (2.06 m)	6' 5" (1.96 m)	6' 1" (1.85 m)
Horizontal	2' 9" (0.84 m)	2' 11" (0.89 m)	3' 1" (0.94 m)	3' 3" (1 m)
Center of Gravity - Stored				
Vertical	1' 7" (475 mm)	1' 7" (493 mm)	1' 8" (506 mm)	1' 8" (518 mm)
Horizontal (C/L Rotation to Bridge)	7.8" (198 mm)	7.4" (187 mm)	6.7" (171 mm)	6" (152 mm)

* Crane rating (ft-lb) is the rated load (lb) multiplied by the respective distance (ft) from centerline of rotation with all extensions retracted and the inner and outer booms in a horizontal position, per ANSI B30.22. ** Crane weight is for standard crane with tank & 8-bolt long mounting kit. Does not include stabilizers, tank or oil.

Standard Features

- Application-specific product offering
- Superior lift-to-weight ratio
- Long-reach capabilities
- Hexagonal booms for superior reach and maximum control
- Integrated hydraulic reservoir in crane base
- Powder coat paint

Options

- Radio remote control
- Boom tip functions for hydraulic attachments

Specifications

Stabilizer Pad Diameter	5.5" (140 mm)
Crane Storage Height	5' 9" (1750 mm)
Mounting Space	1' 9" (530 mm)
Rotational Torque	5065 ft-lb (0.7 tm)
Rotation	400°
Optimum Pump Performance	6.6 gpm (25 L/min)
System Pressure	3915 psi (270 bar)
Oil Reservoir Capacity	6 gal (23 L)
Stabilizer Extension Span	
Standard (manual out/hydraulic down) Weight	9' 11" (3025 mm) 220 lb (100 kg)
Option 1 (manual out/hydraulic down) Weight	13' 7" (4145 mm) 265 lb (120 kg)
Option 2 (manual out/hydraulic down swing-up stabilizer) Weight	16' 2" (4925 mm) 320 lb (145 kg)

Minimum Chassis Specifications

Front Axle Rating (GAWR)	5000 lb (2270 kg)
Rear Axle Rating (GAWR)	9500 lb (4310 kg)
Resistance to Bending Moment Minimum	440,000 in-lb (50,695 kg-m)



Stabilizers

Operators can deploy stabilizers by manually pulling in and out while hydraulic controls move the stabilizers up and down to ensure safe lifting.



Hexagonal Boom Design

A hexagonal profile with large bearing surfaces ensures greater strength and stability for horizontal and vertical spans — even when working in extreme positions with long reaches. Plus, it's protected by powdercoat paint that never fades, flakes, or corrodes.

► 5/33 Capacity Charts

5/33 K1

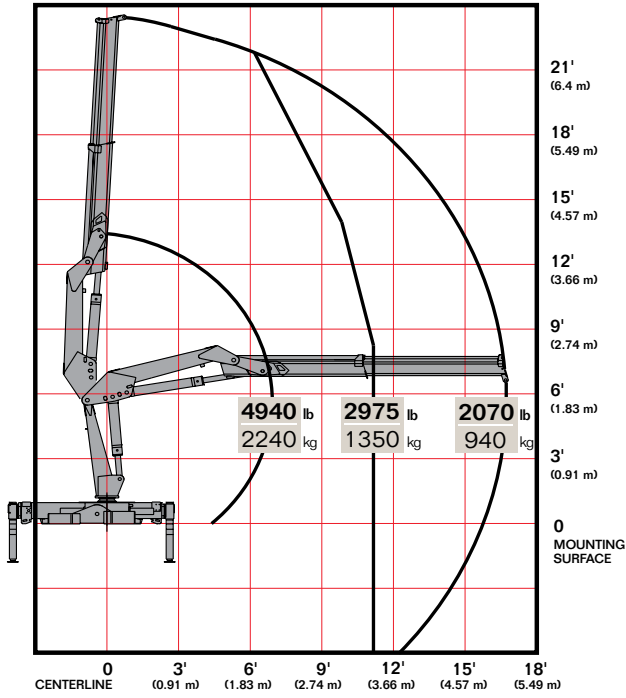

5/33 K2

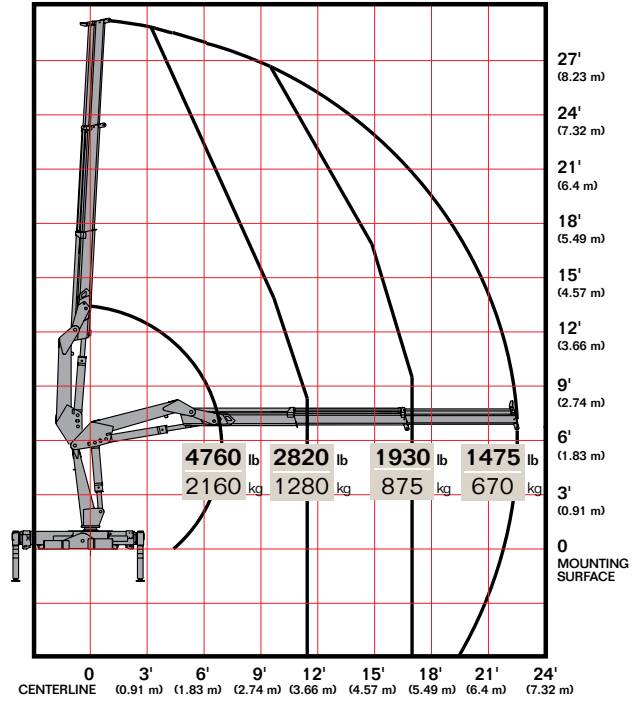

5/33 K3

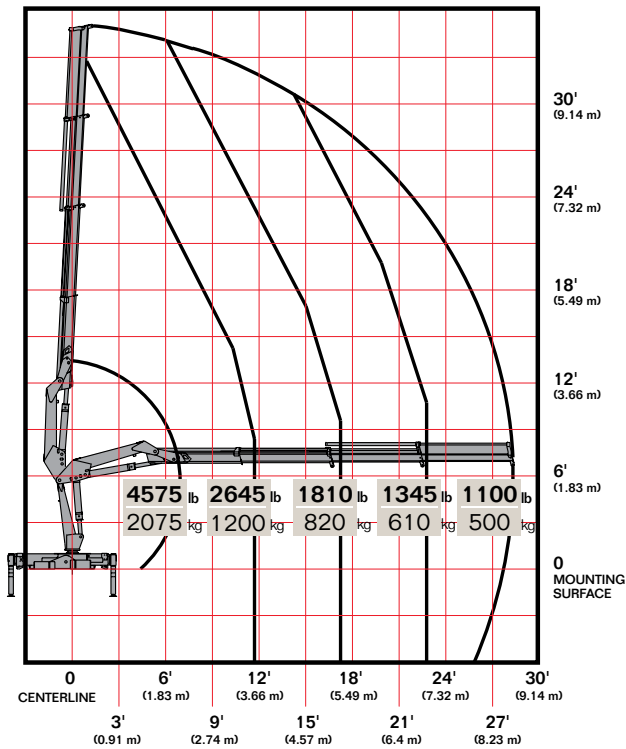

5/33 K4

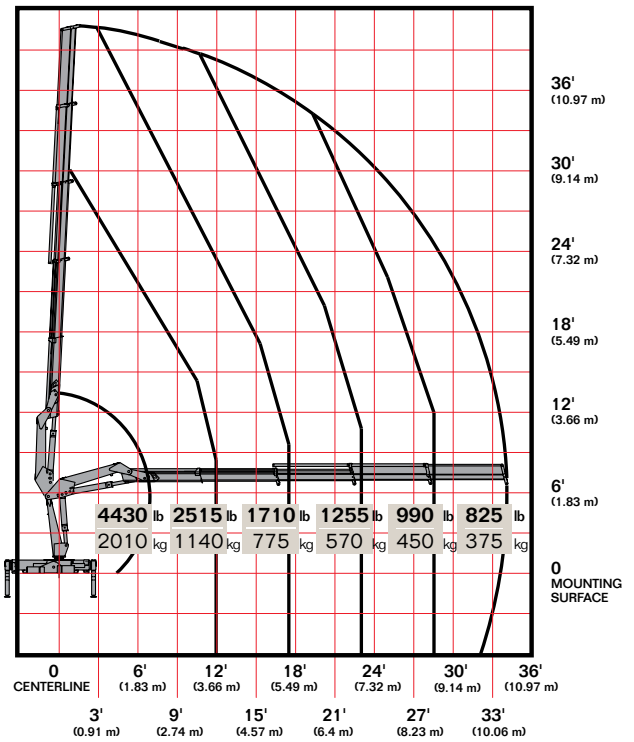

Limit working loads to those shown.
Deduct the weight of load-handling devices.

► 5/33 Lifting Capacity

5/33 - 1 Hydraulic

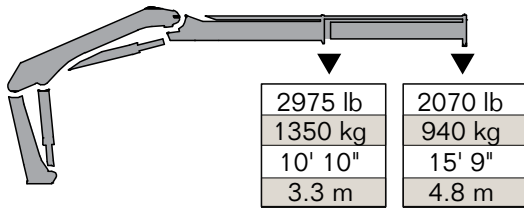

5/33 - 2 Hydraulic

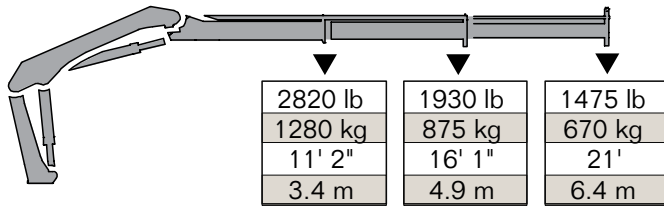

5/33 - 3 Hydraulic

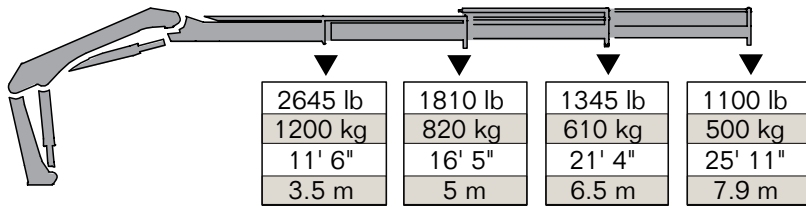

5/33 - 4 Hydraulic

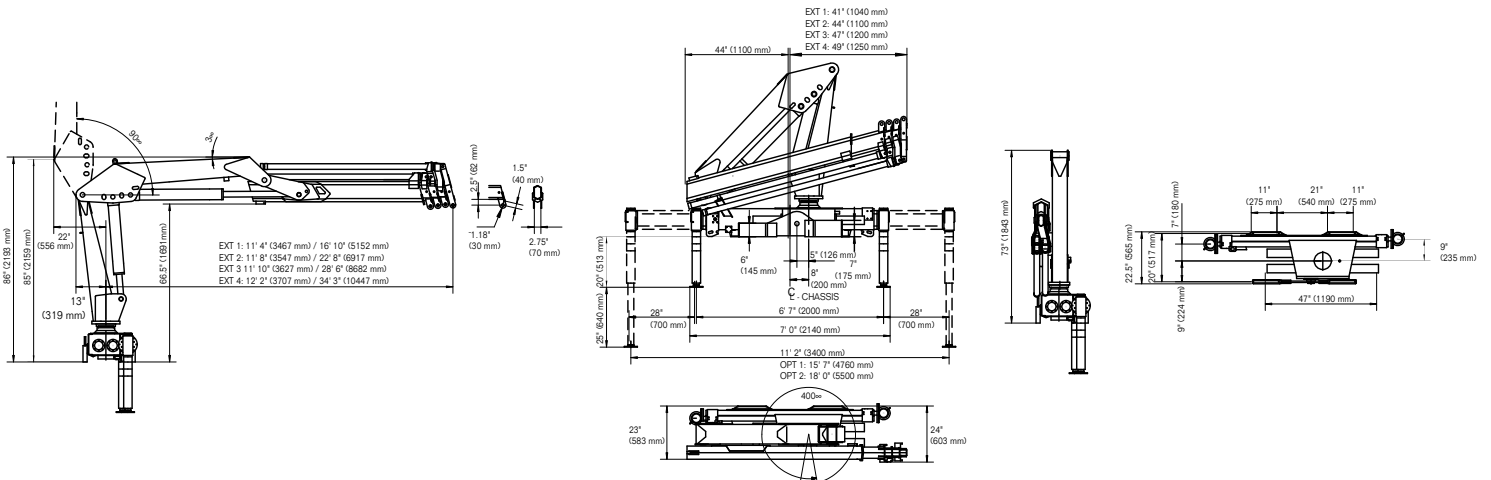
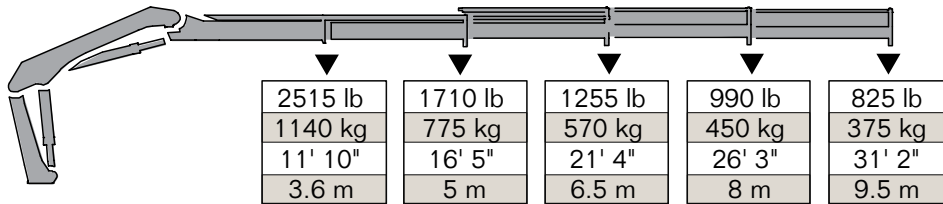

Power Source

- Standard integral-mounted piston hydraulic pump and PTO application

Cylinder Holding Valves

- Integral-mounted counterbalance valves or load-holding check valves
- Prevention of sudden cylinder collapse in case of hose failure

Rotation System

- 400 degree rack and pinion
- 5065 ft-lb (0.7 tm) rotational torque
- Counterbalance valve on each cylinder to stop motion in case of hose failure

Hydraulic System

- Open-centered system — closed optional
- Regeneration system on extension cylinder to ensure quick deployment
- Hydraulic oil reservoir, air breather, replaceable return-line filter, and control valve with levers

Overload System

- Load-limiting capability for boom functions
- Rated capacity limitation (RCL) 5300 blocks load-increasing functions when full capacity is attained



Nothing Says Commitment Like The Diamond.™

IMT has been meeting the needs of our customers for over 50 years and none of it would have been possible without a distributor network that's second to none. IMT distributors offer fast, knowledgeable service and the ability to help customers find the right product for every application. When you're looking for reliable equipment and dependable service, remember IMT.



An Oshkosh Corporation Company

Iowa Mold Tooling Co., Inc.

500 Highway 18 West
Garner, Iowa 50438
800-247-5958 • www.imt.com