

# Shuttlelift CD5520

## Product Guide



### Features

- 18 t (20 USt) capacity
- 16,6 m (54.5 ft) four-section, four-plate full power boom
- 9,07 t (10 USt) deck carrying capacity
- Exclusive pivoting boom nose

# Features



## The reach and capacity to get the job done

The 5,64 m - 16,61 m (18.5 ft - 54.5 ft) four-section boom can be enhanced with optional boom extensions. The 4,6 m (15 ft) fixed swingaway extension offers a maximum tip height of 23,1 m (76 ft) while the 4,6 m - 7,6 m (15 ft - 25 ft) telescopic extension provides a maximum tip height of 26,2 m (86 ft). Both extensions can be offset 0°, -15°, and -30° via the pivoting boom nose.



## Pivoting boom nose

Three-position mechanically offset (0°, 40°, and 80°), lowers boom nose head height by 40,5 cm (1.33 ft) when pivoted fully forward. Negative pivoting of 0°, 15°, and 30° allows boom extension offset capability.

## Steering

The CD5520 comes standard with three steering modes: front (two-wheel), four-wheel coordinated, and four-wheel crab steer with electronic self alignment. Operators can choose between modes using a three-position rocker switch located on dash panel.



## Outriggers

The CD5520 outriggers are two position (0° and 100°) beam/jack style with inverted jack cylinders and pivoting pad.



## Operator cab

New operator control layout with tilt/telescoping steering wheel. Automotive style dash panel gauges and indicator lights.

# Contents

Specifications	4
Dimensions	7
Dimensions and weights	8
Range diagram	9
Load chart	10
Rigging chart	12
Symbols glossary	13

# Specifications

## Superstructure

### Boom

5,64 m – 16,61 m (18.5 ft – 54.5 ft) four-section full power boom.

Maximum tip height: 19,2 m (63 ft)

### \*Optional boom extensions

4,6 m (15 ft) fixed swingaway extension.  
Maximum tip height: 23,1 m (76 ft)

4,6 m – 7,6 m (15 ft – 25 ft) telescopic swingaway extension.

Maximum tip height: 26,2 m (86 ft)

Both extensions can be offset 0°, -15°, and -30° via pivoting boom nose.

### Boom nose

Two sheave, quick reeve type with three- pinned pivoting (0°, +40°, and +80°) design to minimize head space requirements. Lowers head height 40,5 cm (1.33 ft) when nose is pivoted fully forward.

### Boom elevation

Two double acting hydraulic cylinders with integral holding valve. Elevation: 0° to 80°.

### Anti-two block device

Standard anti-two block device (hard wired), which, when activated, provides an audible and visual warning to the operator and “locks out” all functions whose movement can cause two-blocking.

### Load Moment Indicator

A simple, effective, and easy to use load moment indicating system used in conjunction with the anti-two block system to assist the operator in efficient operation of the unit within the limits of the load chart. The display panel displays the max. load allowed, the actual hook load, length and angle of the boom, and load radius in Dot Matrix numerical values and provides a load utilization colored bar graph. Inputs by operator are maximum allowed load and parts of line. If non-permitted conditions are approached the L.M.I. will warn the operator with an audible alarm and a warning light and will lock out those functions that may aggravate the condition.

### \*Load Moment Indicator

“Graphics Display” of boom angle, boom length, load radius, and capacity. Operator input to set the limit parameters based on the load chart. Displays color coded light bar and audible alarm with function cut-out if load exceeds the load chart parameters.

### Swing

Ball bearing swing circle with 360° continuous rotation. Worm gear and pinion driven by hydraulic motor. Spring applied, hydraulic released brake. Maximum speed: 2.5 rpm

### Hydraulic system

One pressure compensated variable displacement axial piston pump, with load sensing.

Maximum output of: 155 LPM (41.0 GPM)

Maximum operating pressure: 276 bars (4000 p.s.i.)

Six-section valve bank, chassis mounted, operated via dash mounted pilot pressure hydraulic joystick controllers.

151,4 L (40 gal) steel hydraulic reservoir with sight level gauge and steel side plating to guard against side impact.

Return line replaceable filter with by-pass protection and service indicator. Cartridge filter rating of three micron.

### Hoist specifications

Two speed gear motor driven hoist with automatic spring applied / hydraulically released wet brake. Smooth drum with cable follower.

Maximum hoist pull (first layer): 63,6 kN (14,300 lb)

Maximum permissible single line pull:  
44,5 kN (10,000 lb.) (3.5:1 design factor)

Maximum single line speed: 64 m/min (210 fpm)

Rope construction: 6 x 19 XXIPS / IWRC

Rope diameter: 14 mm (9/16 in)

Rope length: 97,5 m (320 ft)

# Specifications

## Carrier



### Chassis

High strength alloy frame constructed with integral outrigger housings; front and rear lifting, tie-down, and towing lugs. 66.3 sq. ft. carrydeck size with 9072 kg (20,000 lb) deck only carrying capacity. Deck coated with anti-skid treatment.



### Outriggers

Single stage hydraulic telescoping beam with oblique style jack cylinder on all four corners. Provides extended and down and retracted and down lifting capabilities. Integral holding valve on both beam and jack. Outrigger positioning indicator located in dash display. Outrigger pad size: 222 mm x 254 mm (8.75 in x 10 in)

Maximum outrigger pad load: 15 876 kg (35,000 lb).



### Outrigger controls

Independent outrigger control rocker switches for beam or jack selection with a separate extend /retract rocker selector switch. 360° level bubble located inside cab.



### Engine (Tier IV)

Cummins QSB 3,3 L four cylinder / turbo-charged diesel rated at 75kW (100 hp) at 2600 rpm. Includes standard 110V engine block heater and air intake "Grid" heater. Engine hourmeter located in dash display. Alternator: 120 amp. Maximum Torque: 414Nm (305 ft/lb). Fuel requirements: Maximum of 15 ppm sulphur content Requires "Ultra Low" diesel fuel.

NOTE: Tier IV required for sale in North America and European Union countries.



### Engine (Tier III)

Cummins QSB 3.3L four cylinder / turbo-charged diesel rated at 74kW (99 hp) at 2600 r.p.m. Includes std. 110V engine block heater and air intake "Grid" heater. Engine hourmeter located in dash display. Alternator: 90 amp. Maximum Torque: 415 Nm (306 ft/lb).

NOTE: Required for sale outside of North America and European Union countries.



### Fuel tank capacity

Steel with side impact plate. Capacity: 151,4L (40 gal).



### Transmission

Powershift with four speeds forward and four reverse. Steering column mounted shifter.



### Operators control station

Frame mounted, open air style control station with cab shell includes all crane functions and driving controls and equipped with overhead safety glass. Other standard equipment includes a suspension seat with seat belt, sight level bubble and 1,1 kg (2.5 lb) fire extinguisher, and tilt steering wheel. The dash panel will display the fuel level gauge, water temperature gauge, engine r.p.m., battery voltage, and hour meter. Indicator lights will display parking brake, low transmission pressure, low brake pressure, oscillating axle lock, outrigger position, headlights, work lights (if ordered), and hoist 3rd wrap (if ordered). Crane function indicator and turn signal indicators are also included. The load indicator display will be mounted on the top of the dash panel for direct line of sight for the operator.



### \*Operators control station enclosed

Includes the standard cab shell and all controls and indicators noted above, with the addition of front, rear, and right side glass, a split (two-piece) hinged door with sliding glass, front windshield wiper and washer, hot water heater and defroster with fan and cab dome light.



### Electrical system

One heavy duty maintenance free 12V battery, 820CCA at 0°F.



### Drive

Two-wheel (front-wheel) as standard with four-wheel drive as an option. Drive axles supplied with planetary hubs and limited slip differential.

# Specifications

## Carrier continued



### Steer

Standard three steering modes.  
Front (two-wheel), four-wheel coordinated, and four-wheel crab steer with electronic self alignment.  
Three position rocker switch located on dash panel.

Outside Turning Radius:  
Two wheel steer: 6,2 m (20 ft 4.8 in)  
Four wheel steer: 3,9 m (13 ft 1 in)



### Suspension/axles

Front: Drive / steer in both two-wheel drive and four-wheel drive  
Rear: non-drive with steer in two-wheel drive, drive/steer in four-wheel drive.

Front axle is rigid mounted to frame. Rear axle offers 1.5° of oscillation.



### Brakes

Hydraulic actuated internal wet-disc service brake acting on each drive wheel. Dash mounted rocker switch with indicator light for activating or release of the dry disc parking brake mounted on the transmission output yoke.



### Tires

Tubeless type, semi-aggressive tread. 12.00 R20



### Lights

Full LED lighting includes turn indicators, head, tail, brake, and hazard warning lights recessed mounted.



### Maximum speed

33,8 km/h (21.0 mph)



### Gradeability (theoretical)

68%.....(to drive train stall) NO LOAD  
40%....(to drive train stall) with 9072 kg  
(20,000 lb) DECK LOAD

### Gross vehicle weight (G.V.W.)

16 220 kg (35,758 lb) basic unit with Tier IV engine.

### Miscellaneous standard equipment

18 t (20 USt) two-sheave low profile “galvanize coated” hook block with “quick reeve design”, back-up motion alarm, outrigger motion alarm, no-skid decking, front and rear lifting, towing, and tie-down lugs.

### \*Optional equipment

- ▶ Auxiliary Lighting: Includes cab mounted amber flashing light and dual base boom mounted LED work lights.
- ▶ Convenience Package: Includes front and rear pintle hitch, dual rear view mirrors, head and tail light metal mesh grille covers.
- ▶ Enclosed Cab Package: Includes heater and defroster, cab dome light, all window glass, and two-piece split door.
- ▶ Four-wheel drive
- ▶ Below deck hydraulic tow winch with 4536 kg (10,000 lb) capacity.
- ▶ 4,5 m (15 ft) fixed boom extension
- ▶ 4,5 m – 7,6 m (15 ft – 25 ft) telescopic boom extension
- ▶ Air conditioning (closed cab option required)
- ▶ Hoist third wrap indicator with hoist function cut-out
- ▶ Hoist drum rotation indicator
- ▶ 360° swing lock
- ▶ C.E. compliant package

# Dimensions

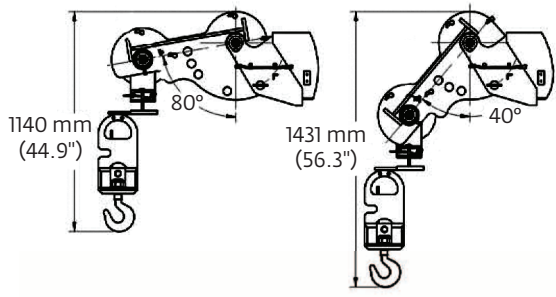

Dimensions					
	A	B	C	D	E
Two-wheel steer	3375 mm (11 ft 1 in)	6058 mm (19 ft 10.5 in)	6218 mm (20 ft 4.8 in)	6675 mm (21 ft 10.8 in)	7407 mm (24 ft 3.6 in)
Four-wheel steer	1722 mm (5 ft 8 in)	3841 mm (12 ft 7 in)	3993 mm (13 ft 1 in)	4481 mm (14 ft 8 in)	5380 mm (17 ft 8 in)

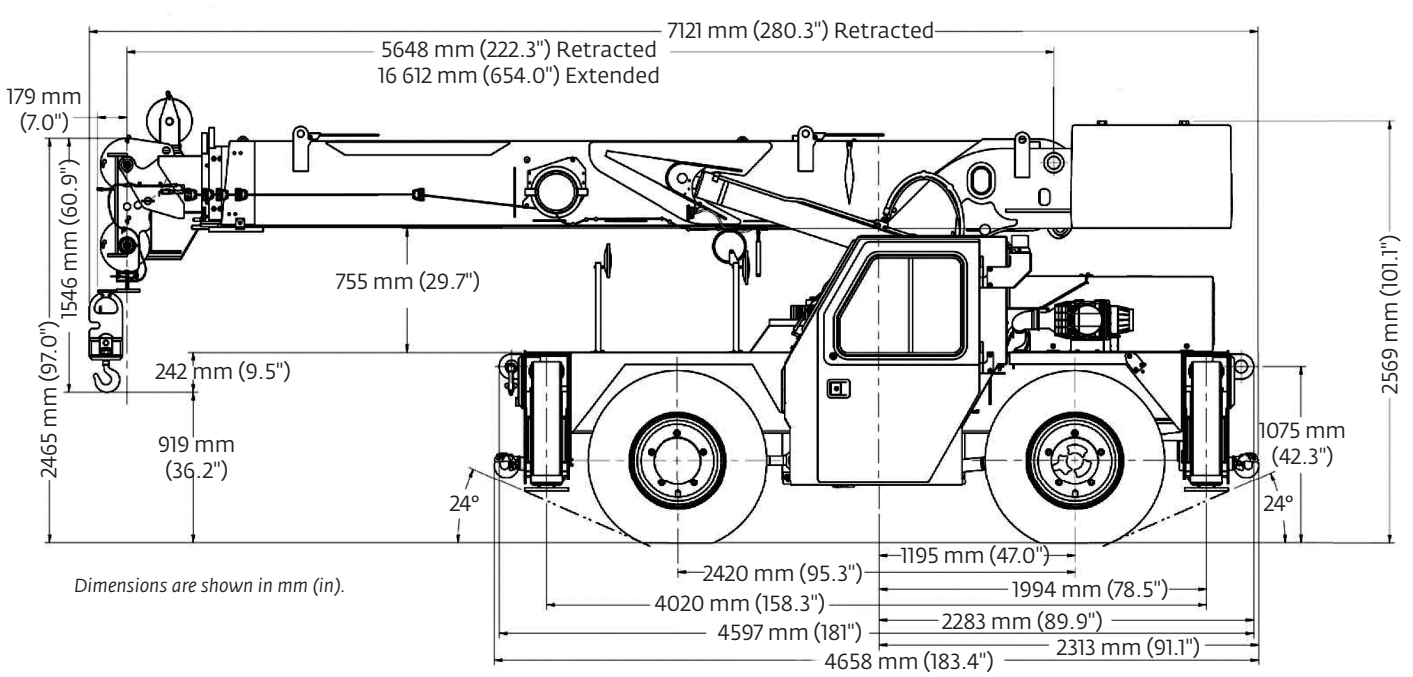
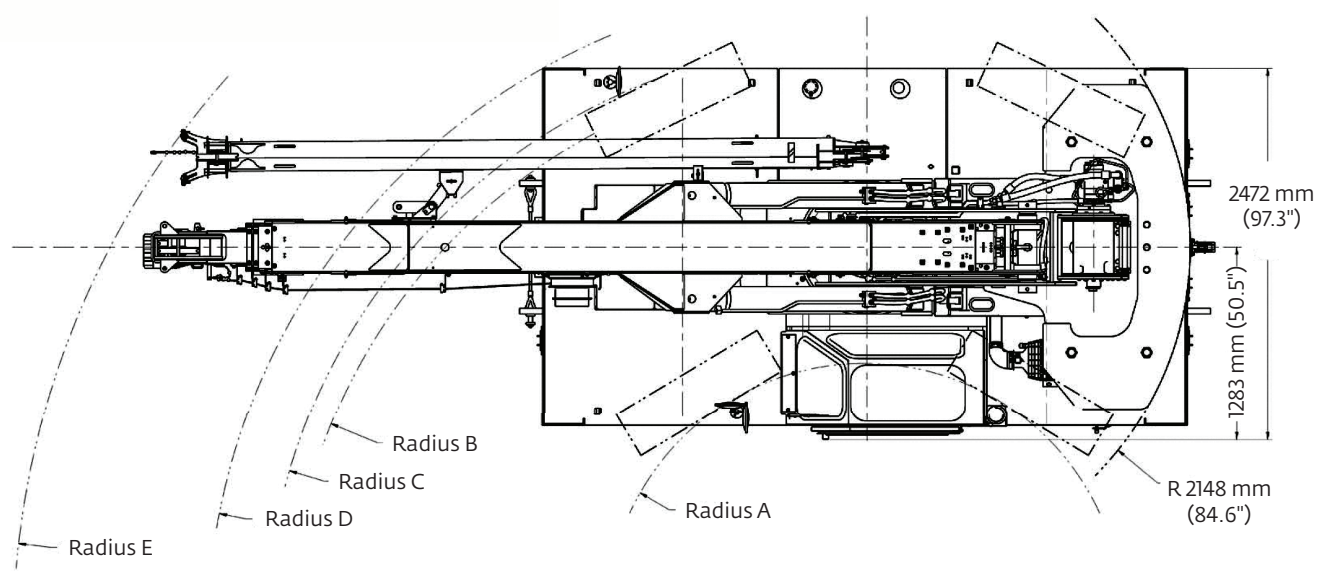

Dimensions are shown in mm (in).

# Dimensions and weights

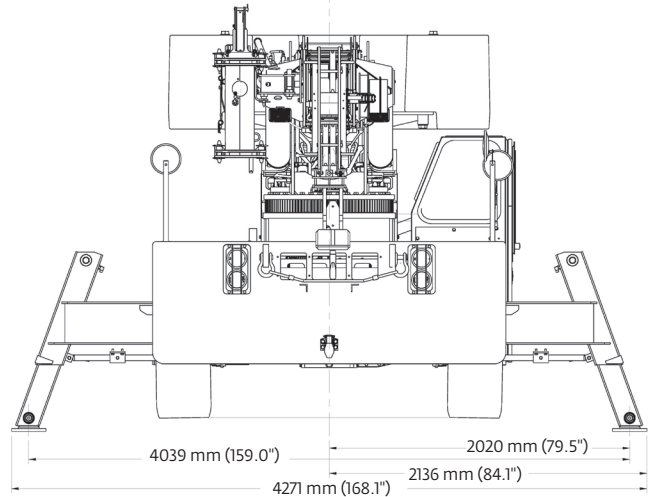
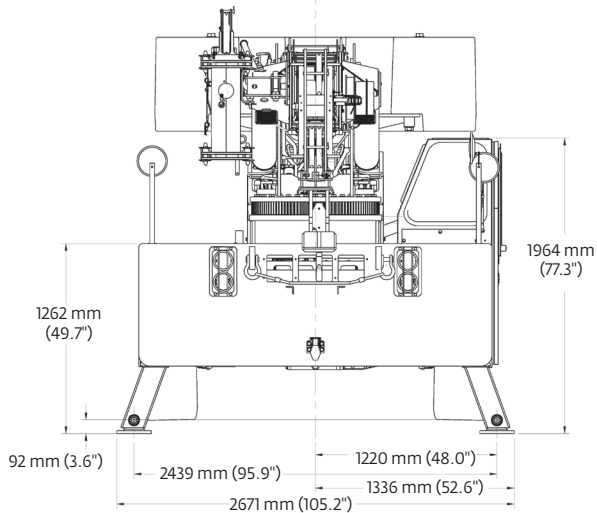
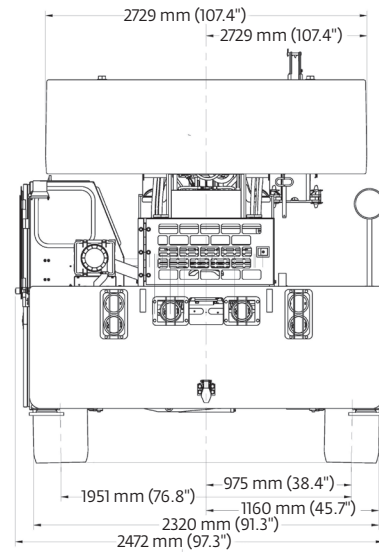
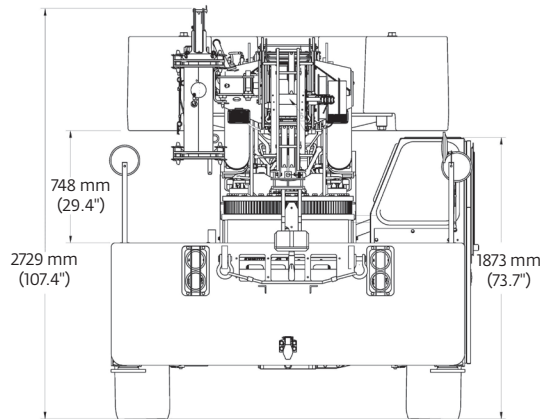

## Weights

	GVW		Front		Rear	
	kg	lb	kg	lb	kg	lb
<b>Basic machine:</b> Including 16,6 m (54.5 ft) main boom, main hoist with 97,5 m (320 ft) of wire rope, 18 t (20 USt) hook block, full counterweight, Tier IV engine	16 220	35,758	6203	13,675	10 017	22,083
<b>Add:</b> 4,6 m (15 ft) fixed swingaway extension and extension carrier brackets and downhaul weight	199	438	323	713	-125	-275
<b>Crane weight</b>	16 419	36,196	6526	14,387	9893	21,809
<b>Basic machine:</b> Including 16,6 m (54.5 ft) main boom, main hoist with 97,5 m (320 ft) of wire rope, 18 t (20 USt) hook block, full counterweight, Tier IV engine	16 220	35,758	6203	13,675	10 017	22,083
<b>Add:</b> Enclosed cab, heater and glass	84,8	187	37,1	82	47,6	105
<b>Crane weight</b>	16 305	35,945	6240	13,757	10 064	22,188
<b>Basic machine:</b> Including 16,6 m (54.5 ft) main boom, main hoist with 97,5 m (320 ft) of wire rope, 18 t (20 USt) hook block, full counterweight, Tier IV engine	16 220	35,758	6203	13,675	10 017	22,083
<b>Add:</b> 4,6 m - 7,6 m (15 ft - 25 ft) telescopic swingaway extension and extension carrier brackets and downhaul weight	344	758	522	1151	-178	-393
<b>Crane weight</b>	16 564	36,516	6725	14,826	9839	21,690



# Range diagram

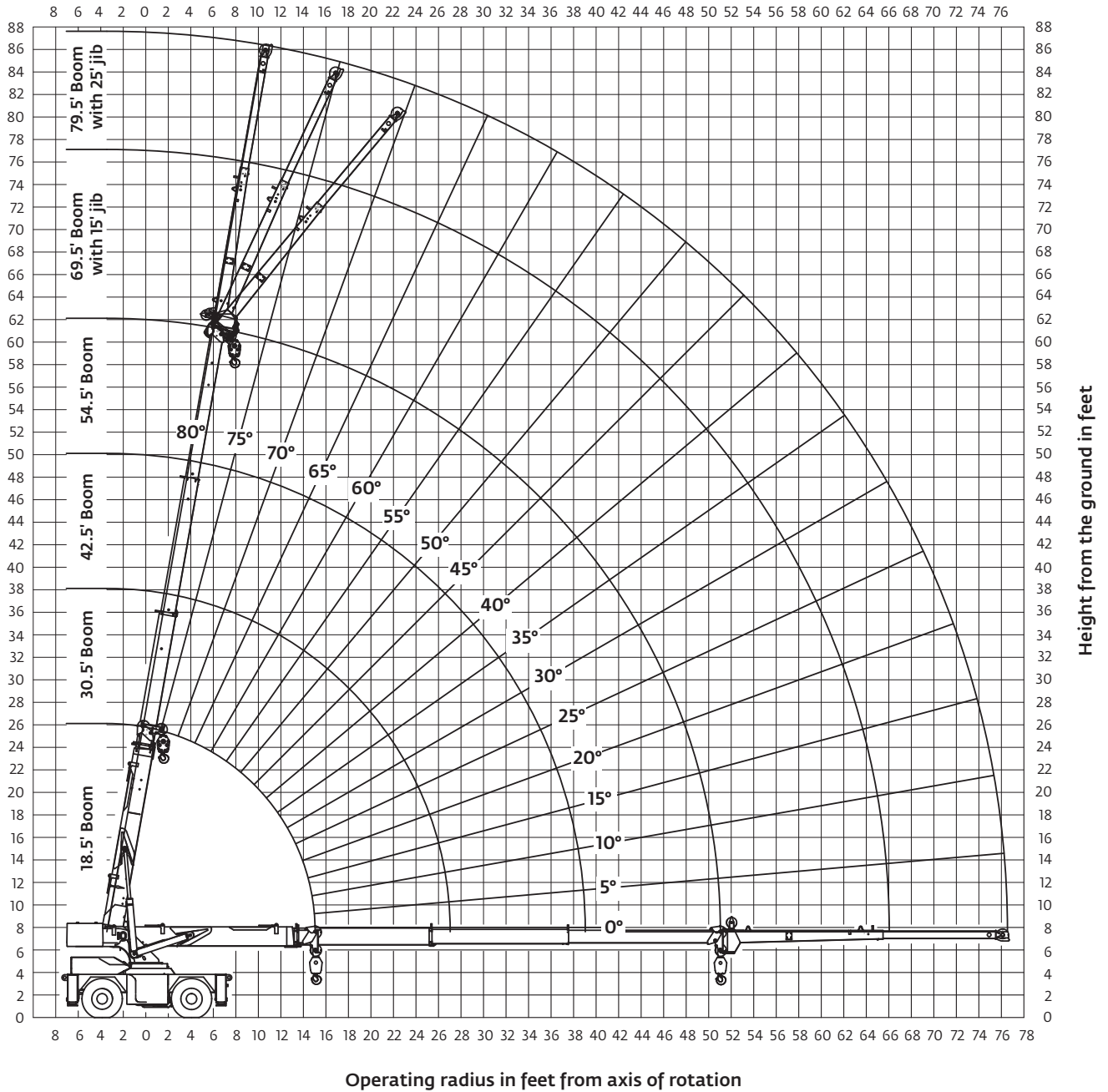

THIS CHART IS ONLY A GUIDE AND SHOULD NOT BE USED TO OPERATE THE CRANE.

The individual crane's load chart, operating instructions and other instructional plates must be read and understood prior to operating the crane.

# Load chart

MAIN BOOM LOAD RATINGS ON OUTRIGGERS Extended and Down 360° or Retracted and Down Front/Rear								
Radius (ft)	18.5 ft BOOM		30.5 ft BOOM		42.5 ft BOOM		54.5 ft BOOM	
	Boom Angle (deg)	Rated Load (lb)	Boom Angle (deg)	Rated Load (lb)	Boom Angle (deg)	Rated Load (lb)	Boom Angle (deg)	Rated Load (lb)
6	65	40000	75.5	24000	-	-	-	-
8	57.5	33850	71.5	24000	77.5	23650	-	-
10	49.5	30100	67.5	24000	75	21550	79	16800
12	39.5	26950	63	24000	72	19850	77	15350
14	25.5	23550	58.5	24000	69	18050	74.5	14100
15	0	18900	56.5	22500	67.5	17250	73.5	13500
16	-	-	54	21000	66	16550	72.5	13000
18	-	-	49	18450	63	15250	70	12100
20	-	-	43.5	16300	60	14250	68	11250
22	-	-	37	14150	56.5	13300	65.5	10550
24	-	-	29.5	12250	53	12200	63	9940
26	-	-	19	10700	49.5	10750	60.5	9380
27	-	-	0	10050	47.5	10150	59.5	9120
28	-	-	-	-	45.5	9600	58	8880
30	-	-	-	-	41.5	8620	55.5	8430
32	-	-	-	-	37	7790	53	8020
34	-	-	-	-	31.5	7090	50	7300
36	-	-	-	-	25	6470	47	6680
38	-	-	-	-	16	5920	44	6130
39	-	-	-	-	0	5680	42.5	5890
40	-	-	-	-	-	-	40.5	5650
42	-	-	-	-	-	-	37	5230
44	-	-	-	-	-	-	33	4850
46	-	-	-	-	-	-	28.5	4500
48	-	-	-	-	-	-	23	4180
51	-	-	-	-	-	-	0	3760

MAIN BOOM LOAD RATINGS ON OUTRIGGERS Retracted and Down 360°								
Radius (ft)	18.5 ft BOOM		30.5 ft BOOM		42.5 ft BOOM		54.5 ft BOOM	
	Boom Angle (deg)	Rated Load (lb)	Boom Angle (deg)	Rated Load (lb)	Boom Angle (deg)	Rated Load (lb)	Boom Angle (deg)	Rated Load (lb)
6	65	40000	75.5	24000	-	-	-	-
8	57.5	33850	71.5	24000	77.5	23650	-	-
10	49.5	24800	67.5	22950	75	21100	79	16800
12	39.5	17900	63	17950	72	16750	77	15350
14	25.5	13750	58.5	14500	69	13750	74.5	13000
15	0	12200	56.5	13000	67.5	12600	73.5	11950
16	-	-	54	11750	66	11500	72.5	11050
18	-	-	49	9780	63	9590	70	9560
20	-	-	43.5	8250	60	8150	68	8360
22	-	-	37	7040	56.5	7030	65.5	7360
24	-	-	29.5	6070	53	6120	63	6430
26	-	-	19	5270	49.5	5380	60.5	5680
27	-	-	0	4930	47.5	5050	59.5	5350
28	-	-	-	-	45.5	4750	58	5050
30	-	-	-	-	41.5	4230	55.5	4520
32	-	-	-	-	37	3780	53	4050
34	-	-	-	-	31.5	3380	50	3650
36	-	-	-	-	25	3040	47	3300
38	-	-	-	-	16	2740	44	2980
39	-	-	-	-	0	2600	42.5	2840
40	-	-	-	-	-	-	40.5	2710
42	-	-	-	-	-	-	37	2460
44	-	-	-	-	-	-	33	2240
46	-	-	-	-	-	-	28.5	2030
48	-	-	-	-	-	-	23	1840
51	-	-	-	-	-	-	0	1580

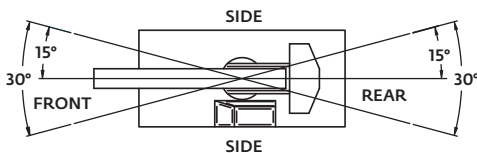

1) The rated loads are the maximum lift capacities as determined by operating radius, boom length and boom angle. The operating radius is the horizontal distance from a projection of the axis of rotation to the supporting surface, before loading, to the center of vertical hoist line or tackle with load applied.

2) The rated loads shown on outriggers do not exceed 85% of actual tipping. The rated loads shown on rubber do not exceed 75% of actual tipping. These ratings are based on freely suspended loads with the crane leveled, standing on a firm, uniform supporting surface. Practical working loads depend on supporting surface, operating radius and other factors affecting stability. Hazardous surroundings, climatic conditions, experience of personnel and proper training must all be taken into account by the operator.

3) The weights of all load handling devices such as hooks, hook blocks, slings, etc., except the hoist rope, shall be considered part of the load. See above.

4) Ratings on outriggers are for either outriggers fully extended and down or fully retracted and down. Ratings for outriggers fully retracted and down will apply for any intermediate outrigger setting.

5) Ratings on rubber depend on 12.00R20 tire capacity, condition of tires and proper inflation pressure (130 psi). Loads on rubber may be transported at a maximum speed of 2.5 mph on a smooth, hard, level surface with boom retracted to the shortest length possible and centered over front. For 360° ratings on rubber, rear axle oscillation locks must be in place. Do not use jib with crane on rubber.

6) For operating radius not shown, use load rating of next larger radius.

7) The maximum deck load only is 20,000 lb. Combined boom and deck loads are not permitted on rubber.

8) Do not induce any external side loads to boom or jib.

**NOTES:**  
SHADED AREAS ARE GOVERNED BY STRUCTURAL STRENGTH, DO NOT RELY ON TIPPING.

OPERATION OF THIS EQUIPMENT IN EXCESS OF RATING CHARTS AND DISREGARD OF INSTRUCTIONS IS DANGEROUS AND VOIDS WARRANTY.

# Load chart

15 FT JIB CAPACITIES ON EXTENDED OUTRIGGERS					
Main Boom Angle (deg)	Jib Offset Angle				
	0 deg		15 deg		30 deg
	To 42.5 ft Main Boom	To 54.5 ft Main Boom	To 42.5 ft Main Boom	To 54.5 ft Main Boom	Any Boom Length
80	—	—	—	—	—
75	9300	6500	7400	5650	3500
70	8550	6100	6950	4350	2800
65	7950	6100	6500	3800	2350
60	7400	5650	5350	3500	2150
55	6950	4350	4550	2800	1900
50	6500	3800	4050	2350	1750
45	5350	3500	3450	2150	1670
40	4550	2800	3000	1900	1550
35	4050	2350	3150	1750	—
30	3450	2150	3000	1670	—
25	3300	1900	2800	1550	—
20	3150	1750	—	—	—
15	3000	1670	—	—	—
10	2800	1550	—	—	—
5	—	—	—	—	—
0	—	—	—	—	—

15 FT - 25 FT JIB CAPACITIES ON EXTENDED OUTRIGGERS										
Main Boom Angle (deg)	15 FT Length					25 FT Length				
	Jib Offset Angle									
	0 deg		15 deg		30 deg	0 deg		15 deg		30 deg
	To 42.5 ft Main Boom	To 54.5 ft Main Boom	To 42.5 ft Main Boom	To 54.5 ft Main Boom	Any Boom Length	To 42.5 ft Main Boom	To 54.5 ft Main Boom	To 42.5 ft Main Boom	To 54.5 ft Main Boom	Any Boom Length
80	8500	8550	5100	4770	3060	5830	5800	3710	3460	2200
75	6990	6650	4400	4100	2640	5120	4860	3190	2970	1890
70	5940	5580	3790	3540	2290	4330	4070	2740	2560	1630
65	5100	4770	3270	3060	1990	3710	3460	2350	2200	1410
60	4400	4100	2810	2640	1750	3190	2970	2020	1890	1230
55	3790	3540	2420	2290	1560	2740	2560	1730	1630	1090
50	3270	3060	2090	1990	1430	2350	2200	1480	1410	990
45	2810	2640	1830	1750	1370	2020	1890	1290	1230	950
40	2420	2290	1630	1560	1370	1730	1630	1140	1090	950
35	2090	1990	1490	1430	1280	1480	1410	1040	990	900
30	1830	1750	1440	1370	1250	1290	1230	1000	950	800
25	1630	1560	1440	1370	—	1140	1090	1000	950	—
20	1490	1430	1440	1280	—	1040	990	900	900	—
15	1440	1370	1250	1250	—	1000	950	800	800	—
10	1440	1370	—	—	—	1000	950	—	—	—
5	1440	1280	—	—	—	900	900	—	—	—
0	1250	1280	—	—	—	800	800	—	—	—

MAIN BOOM ON RUBBER		
Radius (ft)	Any Boom Length	
	Front Rating (lb)	360° Rating (lb)
6	16000	15500
8	14100	13550
10	11250	10800
12	9860	8880
14	8700	7420
15	8190	6800
16	7720	6350
18	6890	5890
20	6180	5070
22	5570	4370
24	4990	3760
26	4460	3250
27	4220	3010
28	4100	2810
30	3680	2690
32	3300	2580
34	2950	2130
36	2640	1890
38	2350	1650
39	2220	1540
40	2160	1420
42	2110	1300
44	1910	1170
46	1720	1030
48	1550	900
51	1310	730

NOTES:  
JIB CAPACITY IS LIMITED BY BOTH STRUCTURAL CAPACITY CHART AND MAIN CAPACITY CHART.

SHADED AREAS ARE GOVERNED BY STRUCTURAL STRENGTH, DO NOT RELY ON TIPPING.

OPERATION OF THIS EQUIPMENT IN EXCESS OF RATING CHARTS AND DISREGARD OF INSTRUCTIONS IS DANGEROUS AND VOIDS WARRANTY.

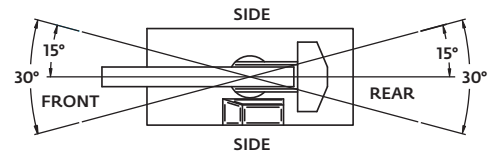

1) The rated loads are the maximum lift capacities as determined by operating radius, boom length and boom angle. The operating radius is the horizontal distance from a projection of the axis of rotation to the supporting surface, before loading, to the center of vertical hoist line or tackle with load applied.

2) The rated loads shown on outriggers do not exceed 85% of actual tipping. The rated loads shown on rubber do not exceed 75% of actual tipping. These ratings are based on freely suspended loads with the crane leveled, standing on a firm, uniform supporting surface. Practical working loads depend on supporting surface, operating radius and other factors affecting stability. Hazardous surroundings, climatic conditions, experience of personnel and proper training must all be taken into account by the operator.

3) The weights of all load handling devices such as hooks, hook blocks, slings, etc., except the hoist rope, shall be considered part of the load. See above.

4) Ratings on outriggers are for either outriggers fully extended and down or fully retracted and down. Ratings for outriggers fully retracted and down will apply for any intermediate outrigger setting.

5) Ratings on rubber depend on 12.00R20 tire capacity, condition of tires and proper inflation pressure (130 psi). Loads on rubber may be transported at a maximum speed of 2.5 mph on a smooth, hard, level surface with boom retracted to the shortest length possible and centered over front. For 360° ratings on rubber, rear axle oscillation locks must be in place. Do not use jib with crane on rubber.

6) For operating radius not shown, use load rating of next larger radius.

7) The maximum deck load only is 20,000 lb. Combined boom and deck loads are not permitted on rubber.

8) Do not induce any external side loads to boom or jib.

THIS CHART IS ONLY A GUIDE AND SHOULD NOT BE USED TO OPERATE THE CRANE.

# Rigging chart

CD5520

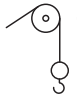
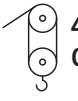
RIGGING CHART	
 <b>1-PART</b> 0-10,000 lb	 <b>4-PART</b> 0-40,000 lb
<b>WIRE ROPE: 9/16" Diameter 6 X 19 Bright</b> <b>Minimum required breaking strength = 37,000 lb</b>	

**MAXIMUM PERMISSIBLE SINGLE LINE PULL = 10,000 lb**

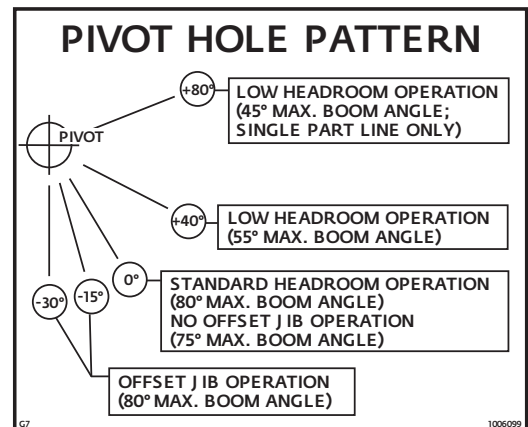

## LOAD DISTRIBUTION CHART

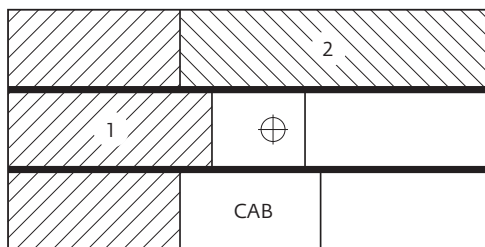

### Maximum Allowable Uniformly Distributed Load

<b>AREA 1</b>	4,01 m <sup>2</sup> (43.2 sq.ft.)	5985 kg (13,195 lb)
<b>AREA 2</b>	2,15 m <sup>2</sup> (23.1 sq.ft.)	3087 kg (6805 lb)
<b>TOTAL</b>	6,16 m <sup>2</sup> (66.3 sq.ft.)	9072 kg (20,000 lb)

1. Maximum travel speed with any or all loads - 4,0 km/h (2.5 MPH)
2. Loads to be transported on smooth level firm surfaces only.
3. Boom must be retracted and in center forward position.
4. Any combination or total of areas 1 and 2 may be used.
5. Lifting is not permitted when carry deck is loaded except for loading and unloading carry deck.
6. Rated pick and carry loads may be transported on deck area 1 provided the load is cribbed directly on the frame rails.

## Rating reductions for load handling devices installed kg (lb)

	From main boom	From jib
Main block	161 kg (356 lb)*	Not applicable
Hook and ball	48 kg (105 lb)*	48 kg (105 lb)
Jib stowed	No reduction	Not applicable
4,6 m (15 ft) jib deployed	317 kg (700 lb)	No reduction
4,6 m - 7,6 m (15 ft - 25 ft) jib deployed	544 kg (1200 lb)	No reduction

\*Refer to rating plate for actual weight

# Symbols glossary



Axles



Counterweight



Grade



Outriggers



Boom



Drive



Heavy duty jib



Radius



Boom elevation



Electrical system



Hoist



Rotation



Boom extension



Engine



Hookblock



Speed



Boom length



Extension



Hydraulic system



Steering



Boom nose



Frame



Lights



Suspension



Brakes



Fuel tank capacity



Oil



Swing



Cab



Gear



Outrigger controls



Tires



Transmission

# Notes



## Manitowoc Cranes

### Regional headquarters

#### Americas

**Manitowoc, Wisconsin, USA**

Tel: +1 920 684 6621

Fax: +1 920 683 6277

**Shady Grove, Pennsylvania, USA**

Tel: +1 717 597 8121

Fax: +1 717 597 4062

#### Europe, Middle East, Africa

**Ecully, France**

Tel: +33 (0)4 72 18 20 20

Fax: +33 (0)4 72 18 20 00

#### China

**Shanghai, China**

Tel: +86 21 6457 0066

Fax: +86 21 6457 4955

#### Greater Asia-Pacific

**Singapore**

Tel: +65 6264 1188

Fax: +65 6862 4040

### Regional offices

#### Americas

**Brazil**

Alphaville

**Mexico**

Monterrey

**Chile**

Santiago

#### Europe, Middle East,

**Africa**

**Czech Republic**

Netvorice

**France**

Baudemont

Cergy

Decines

**Germany**

Langenfeld

**Hungary**

Budapest

**Italy**

Lainate

**Netherlands**

Breda

**Poland**

Warsaw

**Portugal**

Baltar

**Russia**

Moscow

**South Africa**

Johannesburg

**U.A.E.**

Dubai

**U.K.**

Buckingham

#### China

Beijing

Chengdu

Guangzhou

Xian

#### Greater Asia-Pacific

**Australia**

Brisbane

Melbourne

Sydney

**India**

Chennai

Delhi

Hyderabad

Pune

**Korea**

Seoul

**Philippines**

Makati City

**Singapore**

### Factories

**Brazil**

Passo Fundo

**China**

TaiAn

Zhangjiagang

**France**

Charlieu

Moulins

**Germany**

Wilhelmshaven

**India**

Pune

**Italy**

Niella Tanaro

**Portugal**

Baltar

Fânzeres

**Slovakia**

Saris

**USA**

Manitowoc

Port Washington

Shady Grove

This document is non-contractual. Constant improvement and engineering progress make it necessary that we reserve the right to make specification, equipment, and price changes without notice. Illustrations shown may include optional equipment and accessories and may not include all standard equipment.