

6000SLX

GENERAL DIMENSIONS

Unit : mm

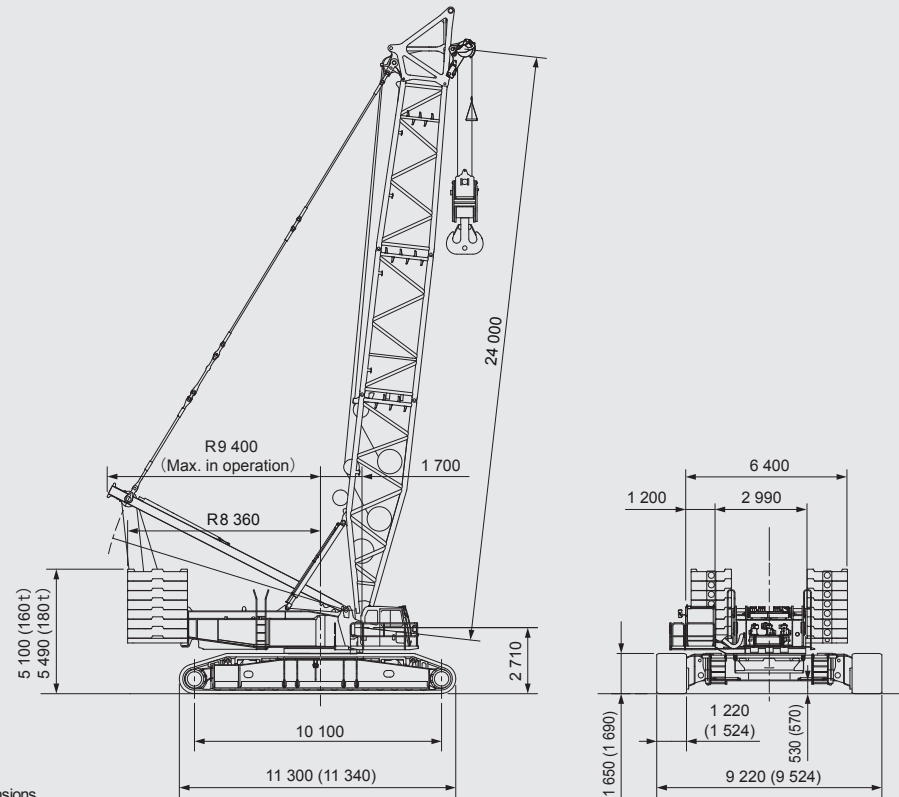

Note : () indicates option dimensions.

SPECIFICATIONS

		STD	SL-N	SL-T	SL-B
Long Mast	m	—	30	30	30
External Counterweight ^(*)	t	—	—	20~260	40~260
Heavy Duty Boom Crane					
Max. Lifting Capacity	t	500	428	550	550
Boom Length	m	24 ~ 96	36 ~ 96	36 ~ 96	36 ~ 96
Long Range Boom Crane					
Max. Lifting Capacity	t	250	200	231	231
Boom Length	m	42 ~ 108	78 ~ 108	78 ~ 126	78 ~ 126
Luffing Jib					
Max. Lifting Capacity	t	210	217	250	250
Tower Length	m	24 ~ 72	36 ~ 72	36 ~ 84	36 ~ 84
Jib Length	m	24 ~ 72	24 ~ 72	24 ~ 84	24 ~ 84
Rope Line Speed (1st layer)^(**)					
Load Hoist Drums	m/min	110	110	110	110
Boom Hoist Drum		40	40	40	40
Luffing Jib Hoist Drum	m/min	49	49	49	49
Working Speed					
Slewing	min ⁻¹ (rpm)		1.0 (1.0)		0.5 (0.5)
Travel	km/h		1.5 / 1.3 / 0.6		
Engine					
Make & Model			Isuzu 6WG1		
Rated Output	kW/min ⁻¹ (PS/rpm)		397 / 1,800 (540 / 1,800)		

Note : 1. Including tray or buggy ^(**)
2. Rope line speeds will vary with the load ^(**)

• We are constantly improving our products and therefore reserve the right to change designs and specifications without notice.
• Units in this catalog are shown under International System of Units (SI). The figures in parenthesis are under the older British Gravitational System of Units.
• Illustrations may include optional equipment and accessories, and may not include all standard equipment.

Address inquires to :

Hitachi Sumitomo Heavy Industries Construction Crane Co., Ltd.

9-3, Higashi-Ueno 6-chome, Taito-ku, Tokyo 110-0015, Japan
Phone: 81-3-3845-1387 Facsimile: 81-3-3845-1394
<http://www.hsc-crane.com>

Printed in Japan
1407©05H.EA198-1a

HITACHI SUMITOMO

The New World Standard Crawler Crane 6000SLX





Efficient Design

Handles Huge Jobs and easily Disassembles for Transport

The 6000SLX can lift 550 t with ease. It is also easily disassembled for transport and promptly set up at the next job site.

Max. Lifting Capacity	STD	SL-N	SL-T/SL-B
Crane (t)	500	428	550
Luffing (t)	210	217	250
Boom Length			
Heavy Duty Boom Crane (m)	24 ~96	36 ~96	36 ~96
Long Range Boom Crane (m)	42 ~108	78 ~108	78 ~126
Luffing Tower (m)	24 ~72	36 ~72	36 ~84
Luffing Jib (m)	24 ~72	24 ~72	24 ~84

Super Lift : SL-B/SL-T

Excellent lifting capacity and wide working range

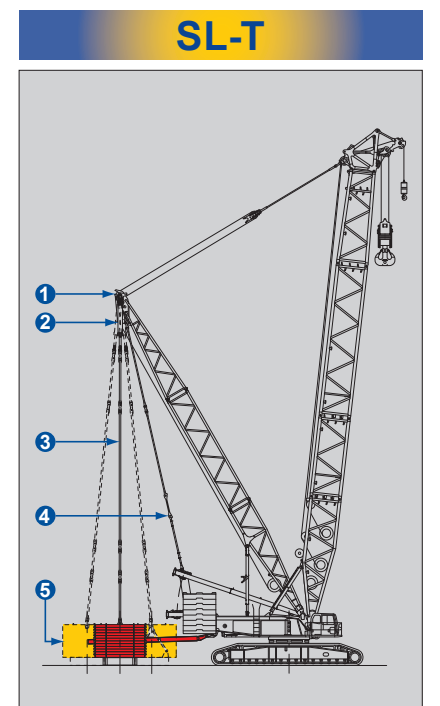
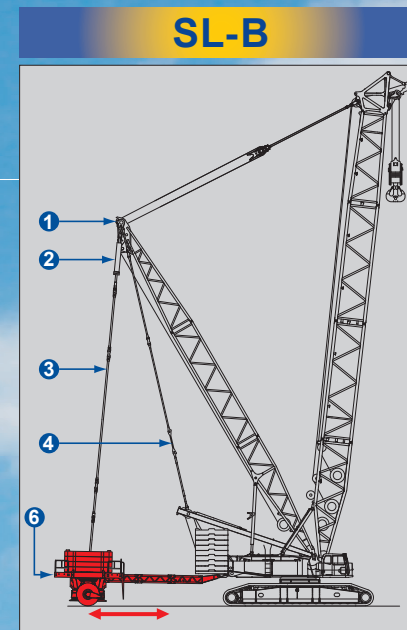

SL-B : Three operating modes can improve performance of the crane.

Slewing Mode

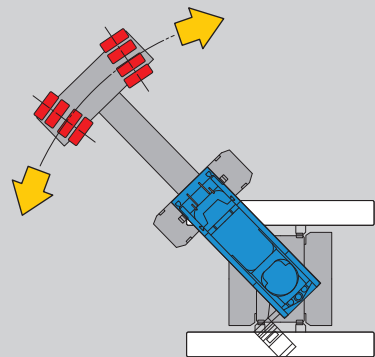

Trailer Mode

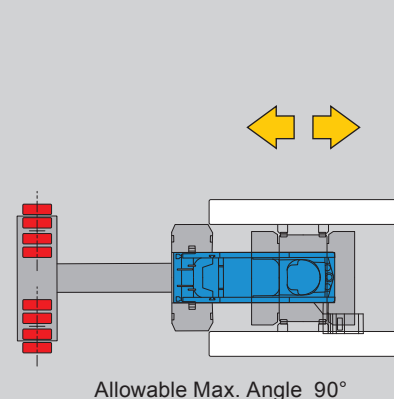

Crab Mode

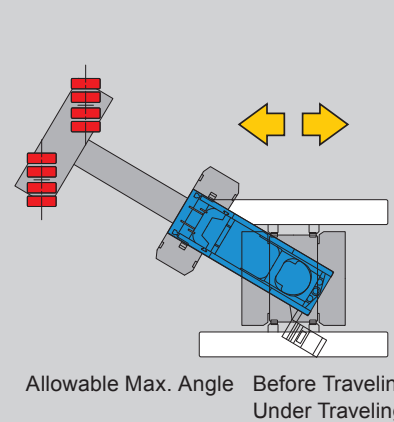

Operating panel for SL-B attachment

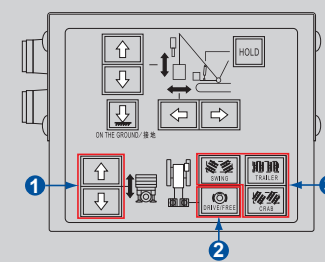

- 1 Jack Cylinder Switch
- 2 Driving Mode Select Switch
- 3 Buggy Operation Mode

1 Fixed Mast top position

Even if mast top position would be fixed at 13.5m from center of rotation, external weight radius can be changed. External weight radius backward is minimum smaller than former model.

2 Suspension cylinder for External weight

Adaption for ground height and adjustment of external weight tension force are available.

3 External weight holding by steel pipe pendant

No stretch by variation of tension force. Oscillating movement of boom back and force is small. Tension force of external weight is surely available.

4 Mast holding by steel plate pendant

No stretch by variation of tension force and it is possible to minimize vibration.

5 Variable beam adjustable cylinder (for SL-T)

Distance of each rotation center between main body and tray weight is retractable from 11m to 16m steplessly. Function of variable stability moment, boom hoist is available with lifting load. By beam connection, at slewing weight and base machine has become unified to make it possible to be stabilized.

SL-T

6 Extension beam (for SL-B)

By using detachable extension beam, buggy can be fixed at three points of 11m/13.5m/16m.

Wide working range

Covers wide range from 350t to 650t class
(middle range boom lifting capacity)



■ Heavy duty tip extension (option)
The best for set up wind power generation

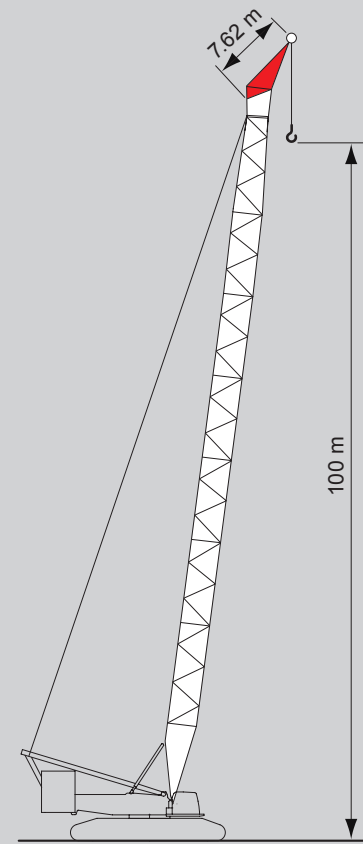

*: It is possible to attach to STD and SL-N specification.

Wide variety of boom configurations, functiona and economical common boom

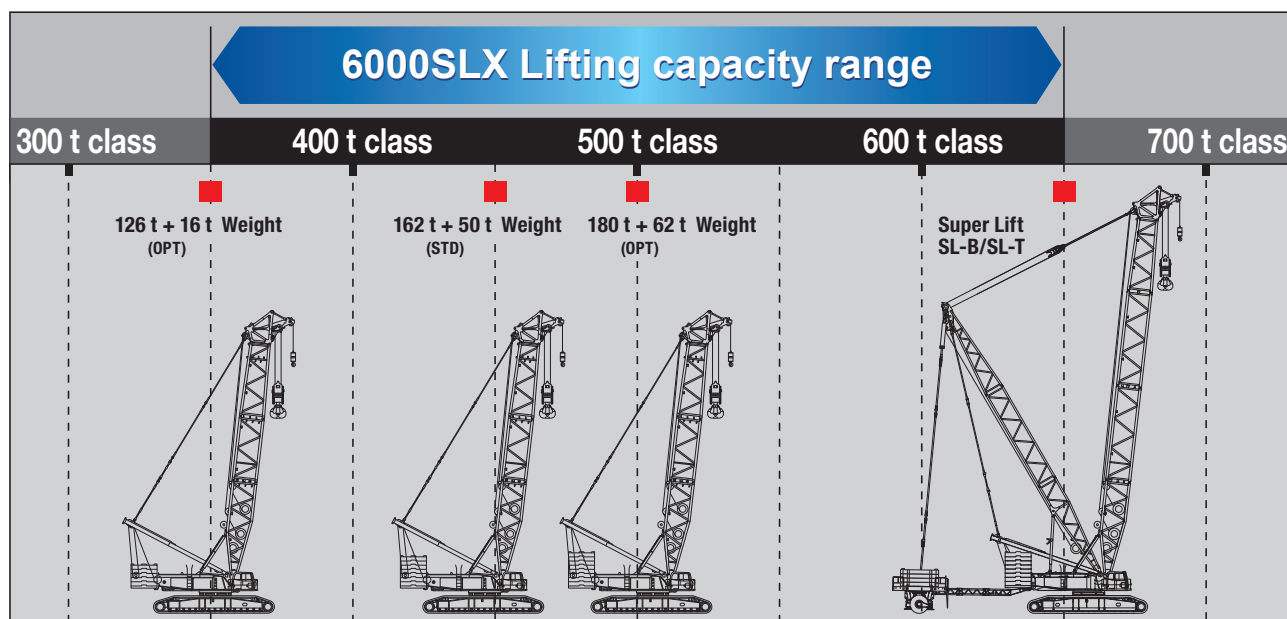
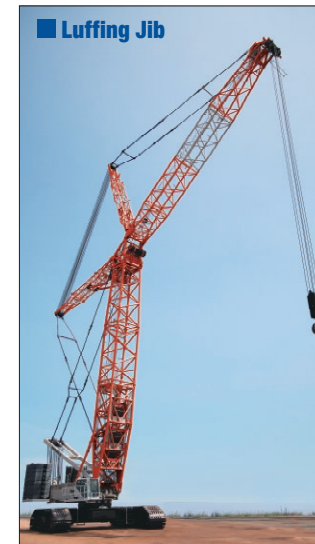

*1: Figures shown in "○t + ○t" indicates mass of counterweight + mass of lowerweight.



* Dimensions shown in () are under STD specification.

Disassembles to Less Than 2 990 mm Transport Width. Uses its Own Power for Assembly and Disassembly.

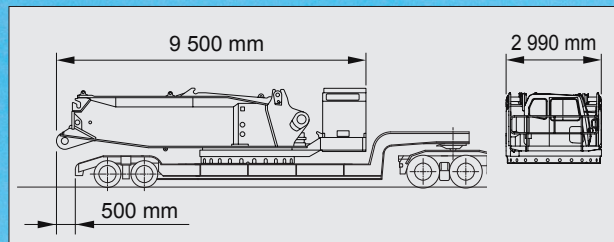

Compact body for excellent transportation

Quick-draw system is available (with load moment indicator) (option)

Upper jack available (option)
The combination of the quick-draw system and Upper jack enables the 6000 SLX to be assembled and disassembled by a single helper crane (60 t RTC), reducing cost.

Hook-on and pin joint type side frame connection device is standard

The hook-on and hydraulic pin joint type that earned a solid reputation on our 120 t and 200 t models now gives the 6000 SLX assembly ease that is equivalent to mid-range models.



Split upper frame with quick disconnect device (option)

By removing boom live mast, rear frame and boom hoist winch as an integrated unit from the front frame, the front frame weight becomes approx. 31 t. Since these items are removed as an integrated unit, there is no need to remove the boom hoist cable from the frame.



Hydraulically assisted connection pin mechanism (option)



Hook-on and pin joint type boom live mast



Hook-on and pin joint type front / rear post and auxiliary jib foot pin

Not only there is no need to align the pins, the operation can be done without the use of hammers. These amenities help to make assembly time 1/3 shorter than on previous models, dramatically reducing the amount of labor required.

Hook-on type jib backstop is standard

The jib backstop can be automatically mounted if the rear post is mounted.

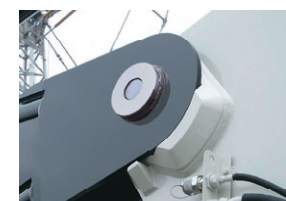

Boom foot pin easy centering design

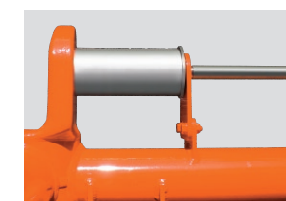

Boom connect pin holding device



Hydraulic type rear post back stop with self-powered assembly and storage device (with luffing specifications)

There is no need for large assisting equipment to do the lifting operations when assembly the rear post. Moreover, the center of gravity is positioned near the assembly area so there will be no unbalance due to weight shifting from front to rear. This enables the assembly to be done quickly and safely.

Go from rear post support pendant connection to tension instantly

Use the hydraulic cylinder to tilt the rear post, connect the pendant and then extend the cylinder to achieve pendant tension. Now this operation, which was once dangerous and required manual power, is no longer necessary. Moreover, the time to perform this operation has been dramatically reduced.



Pendant holding device



laterally symmetrical counterweight

Side jack for long boom self-powered lifting

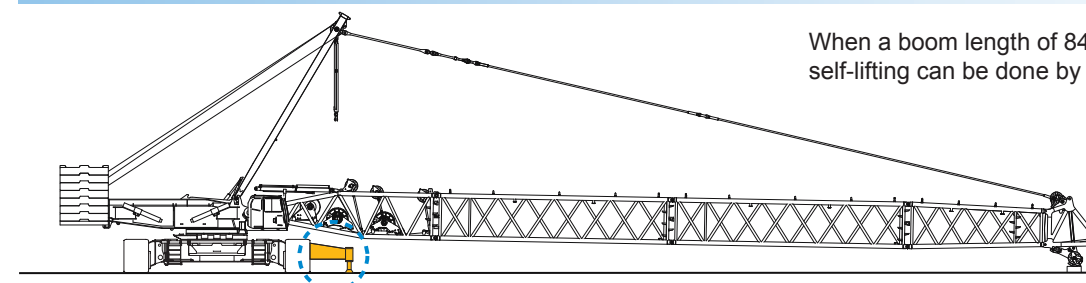

When a boom length of 84 m or more is used, self-lifting can be done by setting the side jack.

Spacious 1 200 mm wide cab ensures a comfortable space for the operator. There is even plenty of room when monitoring instruments are added, which helps to make the operator comfortable for efficient operation.



Comfortable cab offers superior visibility

Unobstructed visibility in all directions teams with the ergonomically positioned joystick and armchair lever controls to boost comfort and efficiency. Operations can be done from a comfortable operating position.

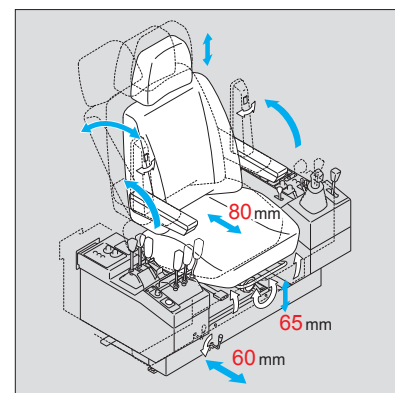

Suspension seat is standard



Strategic lever position

The joystick for slewing and boom hoisting operations on positioned on the left side of the comfortable operators seat. Load hoisting operations are controlled by the levers on the right side of the chair.



Hydraulic slewing brake pedal is standard

Industry Leader in Safety, Maintainability and Environmental Friendliness.



Hydraulic cylinder type boom back stop

The moment limiter and boom back stop limiter will operate to reduce the potential for accidents even if the crane or luffing specifications are incorrectly set. Moreover, boom swaying and harmonics are reduced.



Tags help prevent mis-assembly when extension boom is used

This helps to prevent boom mis-assembly caused by not being able to properly see the identification plates.

Drive tumbler tension adjusting devices are standard

The large, heavy cylinder is equipped in the side frame. Setting is also easy. Connect the hydraulic hoses and turn the valve on.

Auto-greasers for T.T.B is standard

Maintenance of the turntable bearings is easy thanks to the automatic greasing and other such systems.

Highly visible load moment indicator

Easy-to-read high-resolution LCD graphic display is provided. Displays important operating information such as actual load, load ratio, working radius, boom angle, engine rpm and others. Both voice and text messages are used to warn the operator that the crane is about to enter a danger zone.

Flat lower weight and lower frame

Easy to mount lower weight access to the main body is also safe and easy. Moreover, there is plenty of work space.

Easy-access engine layout

Engine maintenance is easy because of the relative arrangement of other components in the engine compartment. The engine cover can be opened even when the mast is stored.

Less load on the environment

The prime mover is from Isuzu, a reliable diesel engine manufacturer, and meets current EU Emission Regulations for Off-Road Diesel Engine-Stage 3.