



Custom Built Marine & Offshore Cranes

FULLY FOLDABLE CRANE

HLM 25-4S MODEL

TECHNICAL SPECIFICATION

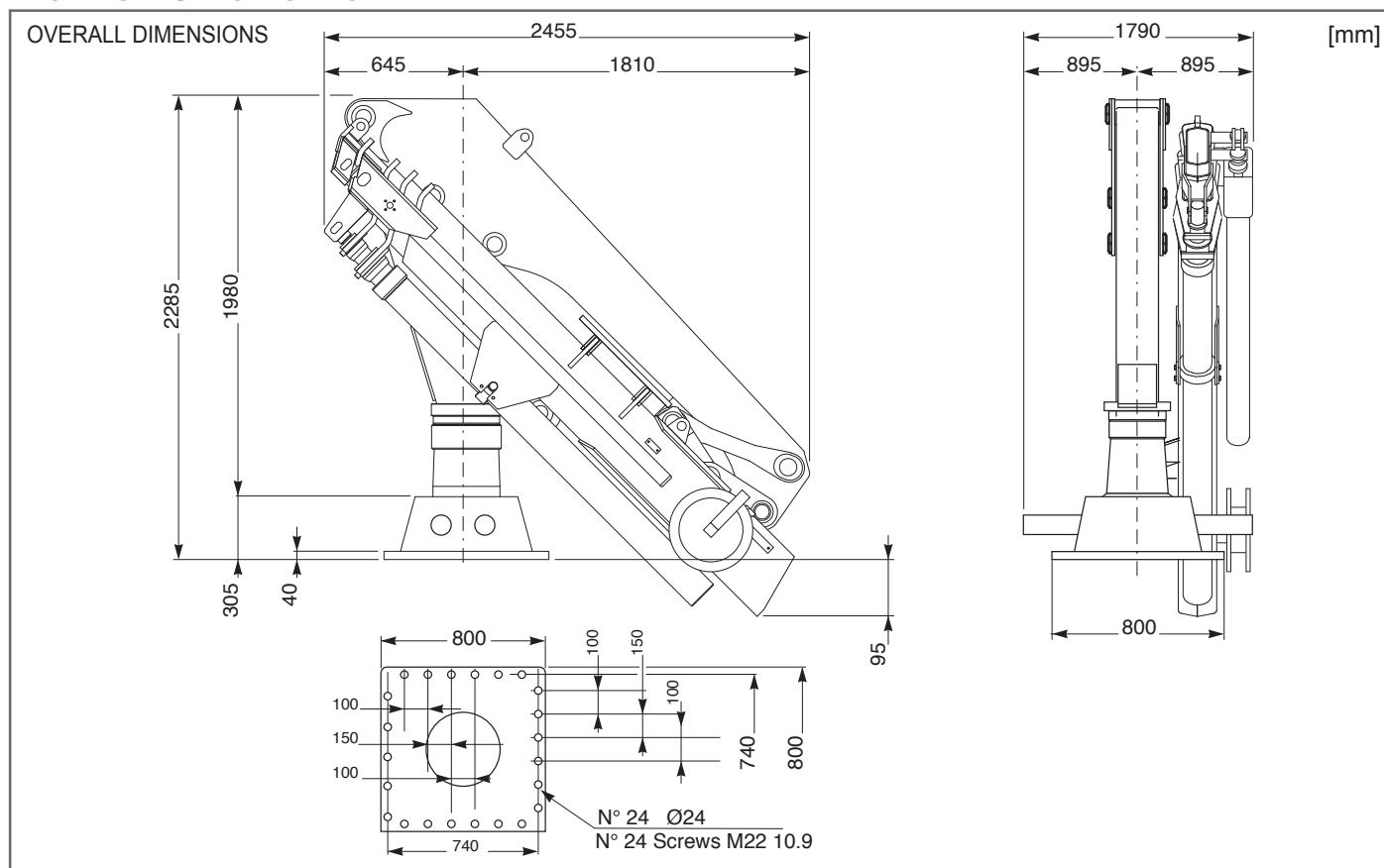

TECHNICAL DATA					
Hydraulic extensions	N°	4	Empty weight of the crane	kg	3250
Net lifting moment	t-m	25	Recommended amount of oil	lt	180
Slewing torque	kg-m	2900	Slewing speed	rpm	1
Slewing angle (continuous)	°	400	Main boom lifting time	sec	50
Pump capacity	lt/min	50	Secondary boom articulation time	sec	50
Max working pressure	bar	240	Boom element extension time	sec	70
STANDARD FEATURES			AVAILABLE OPTIONS		
			1500 kg direct pull winch rope Ø 10		
			Winch limit switch		
			Column-mounted control panel		
			Load limiting device		
			Size 5 electrohydraulic power pack (HP 30)		
			Control panel out of the crane		
			1st manual extension 1100 kg @ 14,70 m (**)		
			2nd manual extension 650 kg @ 16,78 m (**)		
			(**) The use is not allowed for winching purposes		

October 2014

HLM25-4S Rev.00

The technical data contained in this card are only indicative and can be changed without notice.

HEILA CRANES S.p.A. | Via Romana 34/6 - 42028 Poviglio (RE) Italy | info@heila.com | www.heila.com



Custom Built Marine & Offshore Cranes

FULLY FOLDABLE CRANE

HLM 25-4S MODEL

TECHNICAL SPECIFICATION

(ONLY FOR USE WITH HOOK - SEA STATE - 0 - OR HARBOUR CONDITION)

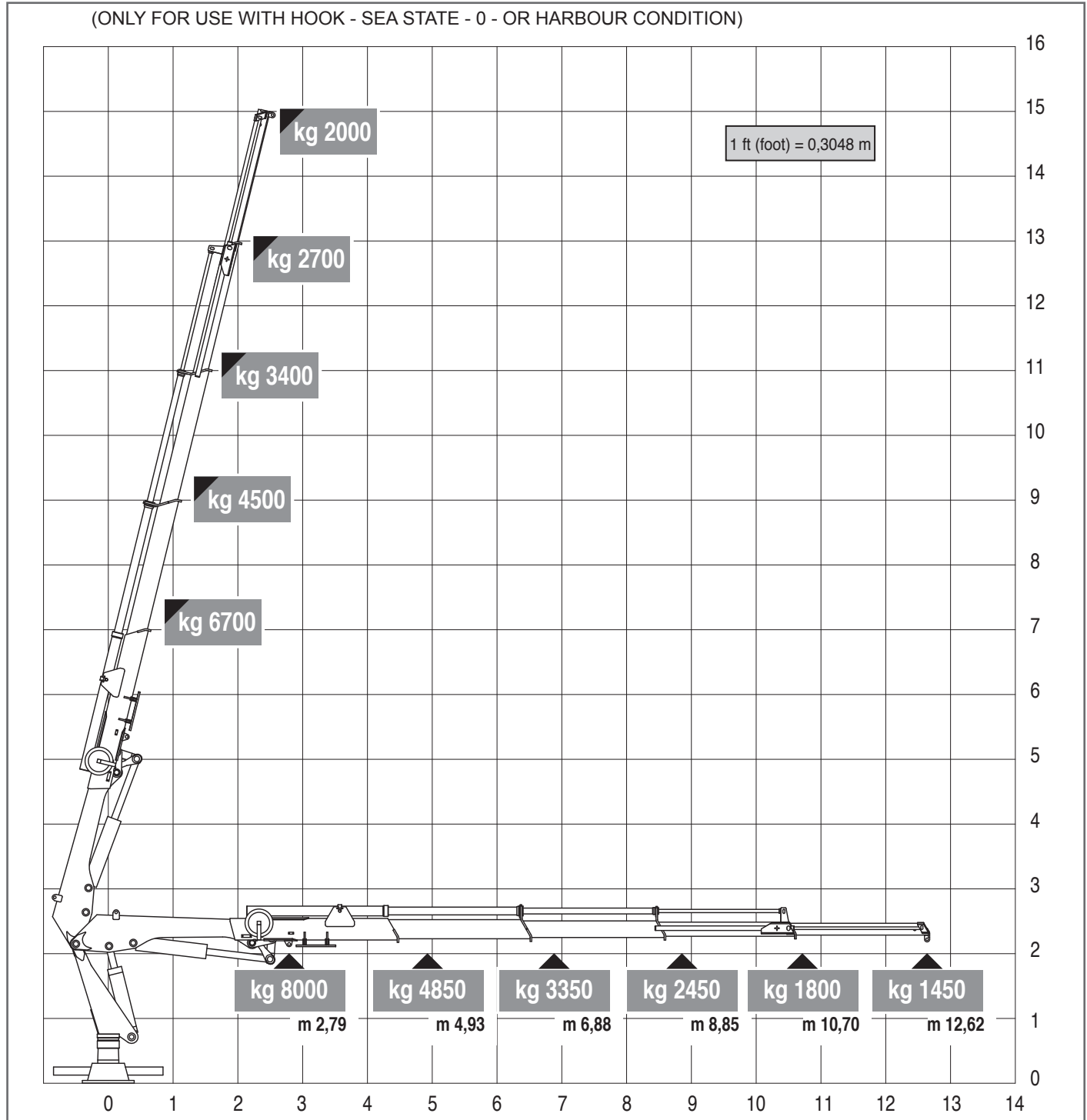

October 2014

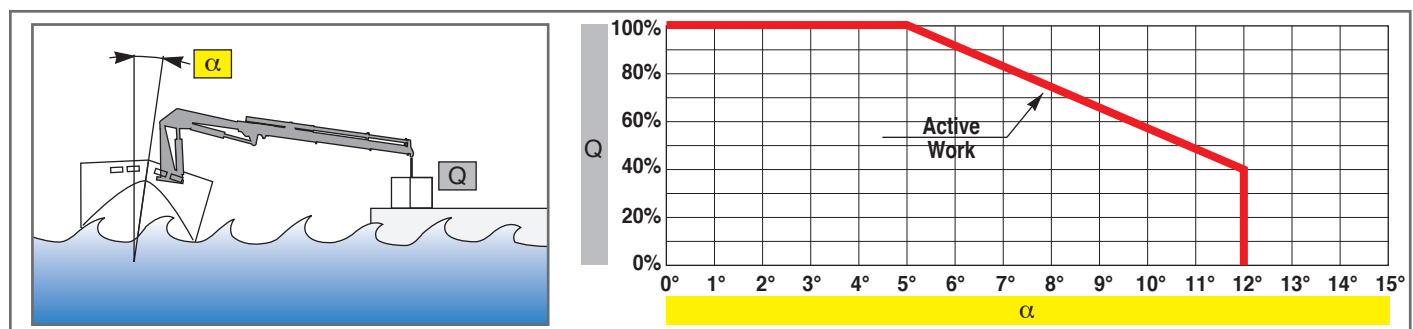

The technical data contained in this card are only indicative and can be changed without notice.

HLM25-4S Rev.00