

F 330A.23

use and maintenance

Edition CE 00 28.04.03

INDEX

Chapter I	INTRODUCTION	page 2
II	SAFETY NORMS	page 3
III	INSTRUCTIONS FOR CRANE USE	page 6
IV	IDENTIFICATION OF THE CRANE MODEL	page 7
V	TECHNICAL DATA	page 8
VI	CRANE NOMENCLATURE	page 10
VII	SAFETY AND PROTECTION DEVICES	page 12
VIII	LIFTING MOMENT LIMITING DEVICE - ROTATION LIMITING DEVICE AND CONTROL PANELS	page 14
IX	CONTROLS TO STABILIZE THE VEHICLE	page 18
X	CONTROLS TO OPERATE THE CRANE	page 23
XI	USE OF IMPLEMENTS	page 26
XII	MAINTENANCE INSTRUCTIONS	page 31
XIII	POSSIBLE FAULTS	page 36
XIV	HYDRAULIC AND ELECTRIC SCHEMATICS	page 37
XV	OIL AND LUBRICANT CHARACTERISTICS	page 45
A	INSTRUCTION AND WARNING PLATES	page 46
B	CAPACITY PLATES	page 49

FASSI CRANE

F 330A.23

use and maintenance

This instruction manual describes the FASSI CRANE F330A.23.

The crane, which conforms to the Machines Directive (D.M.) 89/392 and successive amendments, 91/368 and 93/44 must not be put into service within the European Community unless the machine on which it is mounted also conforms with the prescribed Directive.

The fitment must be carried out in accordance with the instructions given by the Manufacturer in the manual for hydraulic crane fitting.

The Manufacturer declines all responsibility and guarantee if the fitting is entrusted to workshops without sufficient technical capability to carry out the work in conformity.

Every change of use, modification or addition of accessories, must be affixed with a new CE mark in accordance with the Machinery Directive.

As well as the principal safety norms, this manual contains a description of the crane and the instructions for use and maintenance.

Equipment other than Fassi must be supplied with its own use manual.

The crane must only be operated by responsible persons, previously instructed and authorized.

THANK YOU FOR SELECTING ONE OF OUR CRANES.

SAFETY NORMS

(!) This symbol draws your attention on the points concerning safety.
It means: **WARNING! BE CAREFUL!
IT CONCERNS YOUR SAFETY!**

!ATTENTION!

READ THIS MANUAL CAREFULLY prior to use of the crane or any maintenance.
A few minutes spent now could save time and labour later.
Be sure that the unit has been installed, inspected and tested in accordance with the local legal requirements.

To operate the crane it is necessary to fully understand its working, safety and warranty norms.

Warning plates, as well as instruction and operation plates must be replaced when no longer readable or missing. (See chapters A - B)

Check that all safety devices are fitted and working.

Do not run the engine in a indoor area without first making sure there is adequate ventilation. Fit a suitable extension tube to the vehicle exhaust pipe to take the fumes away from the working area.

Stabilize the vehicle by means of the outrigger rams, checking that they rest on a solid base; if in doubt use special larger outrigger base plates (available on request). (See chapter IX)

Level the crane so as it is always operated on a horizontal plane.

Check that the taps of the outrigger rams safety check valves are closed. Never operate the outriggers when the crane is loaded.

Remember that the stability of the unit (crane-vehicle) is only guaranteed by the maximum lateral extension of the outriggers.

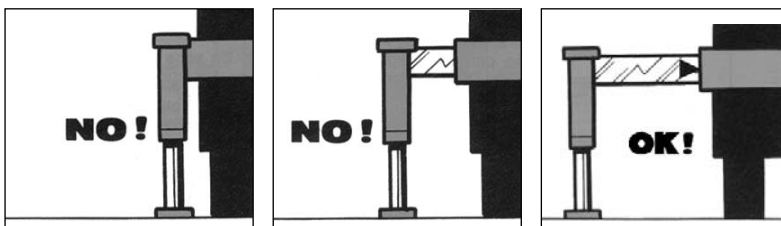

Should visibility be insufficient, make sure that control stations are properly lighted.



ted so as to ensure safety while operating control functions and allow reading of the plates.

Before manoeuvring a load check that the working area is adequate and properly light for your crane.

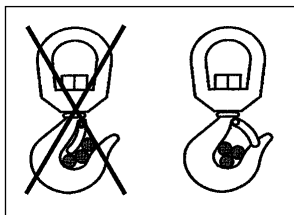

Make sure that the hook is always free to rotate on its pin and that nothing obstructs its vertical positioning.

Check the efficiency of the hook safety catch.

Carefully inspect the load rigging and the condition of ropes or chains.

Make sure that the lifted load is balanced.

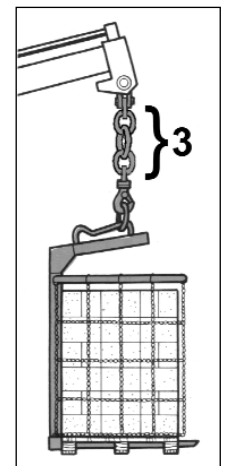

The pallet fork must be connected to the crane hook by means of a chain having at least 3 rings.

Hook up the load, checking that it does not exceed the capacity indicated on the lifting diagram specific to each load configuration.

It is absolutely prohibited to walk or stop under a suspended load and for unauthorized persons to be within the working area.

Avoid swinging the load above the control station; in cases where the load is too close, the crane must be operated from the opposite side.

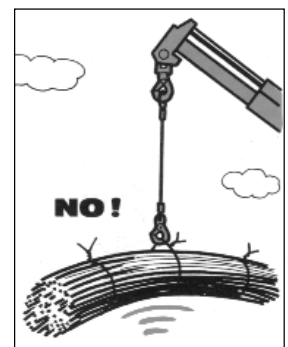
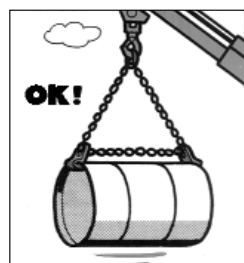

FASSI

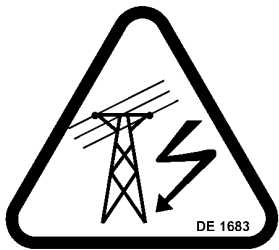
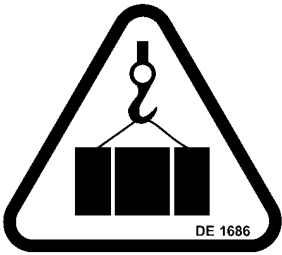

It is absolutely prohibited to load or unload under or in proximity of electric lines.

(!) The minimum distance from electric lines is, according to CEN norms, **5 meters**, except for otherwise prescribed by national norms.

For cranes with top seat controls, it is necessary to use a ladder to reach the control station.

When operating from the top seat, stay within its side safety guards.

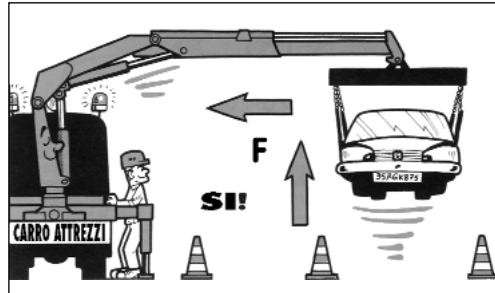
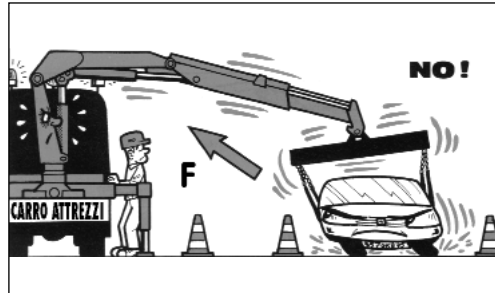
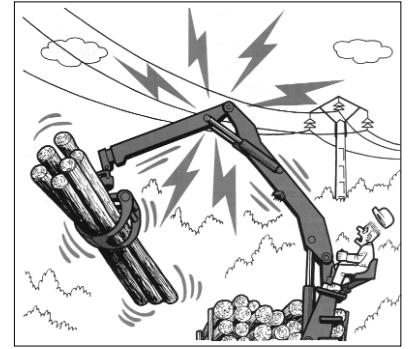

Do not rotate the crane before the load is lifted, do not operate with sudden movements, activate the controls with slow and progressive movements. Rotate slowly and with care paying attention to the stability of the vehicle.

With vertical lift, on hydraulic and mechanical extension, rotate slowly in order to avoid side-skidding.

Do not move the vehicle if a load is suspended on the crane.

Do not utilize the crane for pushpull (F), lateral (F) or sideways (F) operations.

Under no circumstances interfere with the safety and protection devices.

The vehicle/crane are not left unless the power take off is disengaged and the load is on the ground.

At the end of the job and prior to driving the vehicle the crane must be folded. If the booms are to be laid on the body or on the load, they must be blocked to prevent possible sideways movements. Outrigger rams must be lifted and re-entered within the overall width of the truck and safety devices locked.



Check that the taps of the outrigger rams safety check valves are closed.

Disengage the power take off.

To avoid hitting bridges or tunnels check and record the overall height of your crane in the folded position or in laid position in the body or on the load. Always respect and pay proper attention to road signs placed in proximity of such obstacles.

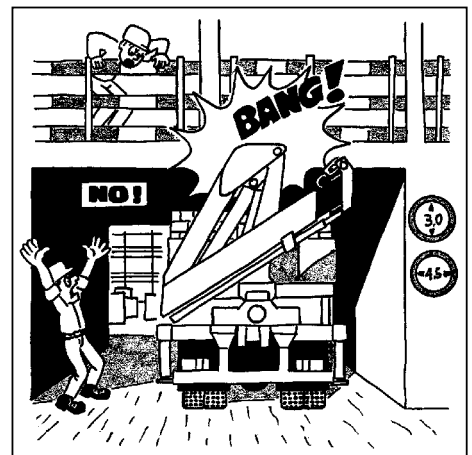
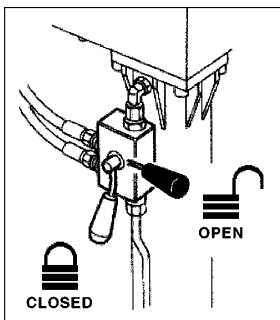

INSTRUCTIONS FOR CRANE USE

The use of the crane is reserved to authorized personnel, instructed in advance, who has to strictly conform to the safety norms and instructions contained in the instruction manual supplied with the crane.

- 1 — Only authorized persons are allowed to operate the crane.
- 2 — The crane must be used on firm, level ground.
- 3 — Check that the vehicle hand brake is on and that the wheels are chocked.
- 4 — Before every operation make sure that:
 - no-one is within the working area of the crane
 - the safety devices are in place and operative
 - the minimum safe working distances from power lines are observed.
 - the load is correctly slung and hooked.
- 5 — Stabilize the vehicle by the outrigger rams, making sure that:
 - the lateral supports are fully extended
 - the wheels are in contact with the ground and the suspension is not completely unloaded
 - the outriggers safety taps are closed.
- 6 — Use the crane in accordance with the use and maintenance manual, making sure that:
 - the load and radius are within the maximum limits shown on the crane capacity plate
 - the crane is used progressively avoiding sudden load movements
 - swinging or dragging of the load is avoided
 - the load is lifted before rotating.
- 7 — When using implements protect the crane working area with a barrier.
- 8 — The vehicle/crane are not left unless the power take off is disengaged and the load is on the ground.
- 9 — Before driving the vehicle make sure that the outriggers are fully retracted and re-entered, the safety taps closed and the crane is in folded position.

fig. 1

	FASSI GRU S.p.A. Via Roma, 110 24021 ALBINO (BG) - ITALIA Tel. 035 / 77.64.00 - Fax 035 / 75.50.20	INSTRUCTIONS FOR SAFE USE OF THE CRANE	DE1771A					
1 Only authorized persons are permitted to operate the crane.	2 The crane must be used on firm, level ground.	3 Check that the vehicle hand brake is on and that the wheels are chocked.	4 Before operation make sure that: <ul style="list-style-type: none">- no one is within the working area of the crane;- the safety devices are in place and operative;- the minimum safe working distances from power lines are observed;- the load is correctly slung and hooked.	5 Stabilize the vehicle with the outriggers, making sure that: <ul style="list-style-type: none">- the lateral supports are fully extended;- the wheels are in contact with the ground and the suspension is not completely unloaded;- the outriggers safety taps, if present, are closed;	6 Use the crane in accordance with the use and maintenance manual, making sure that : <ul style="list-style-type: none">- the load and radius are within the maximum limits shown on the crane capacity plate;- the crane is used progressively avoiding sudden load movements;- swinging or dragging of the load is avoided;- the load is lifted before rotating.	7 When using implements protect the working area with a barrier.	8 The vehicle/crane are not left unless the power take off is disengaged and the load is on the ground.	9 Before driving the vehicle ensure that the outriggers are fully retracted and re-entered, the safety taps closed and the crane is in the folded position.

THESE INSTRUCTIONS FOR THE USE OF THE CRANE COINCIDE WITH THOSE OF THE PLATE DE1771 (fig. 1) PLACED NEXT TO THE CRANE.

IDENTIFICATION OF THE CRANE MODEL

Essential data for the identification of the crane are given on the plate DE1661 used for the CE mark and fixed to the base. (Fig. 2)

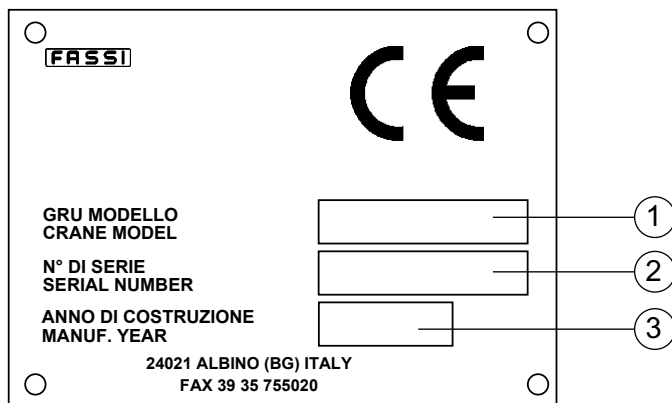

fig. 2

- 1 — Crane model
- 2 — Serial Number
- 3 — Year of manufacturing

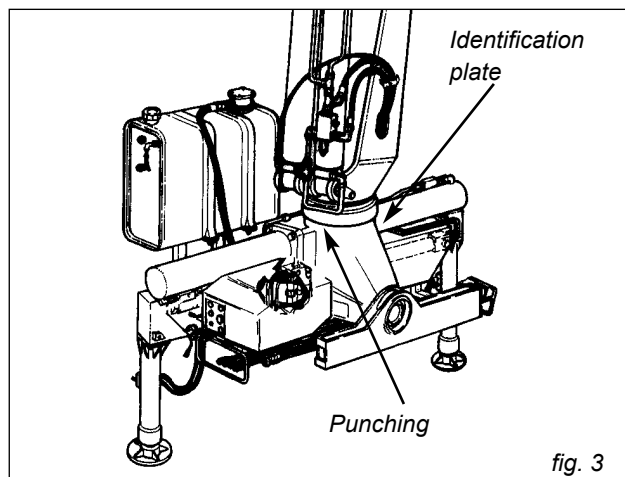

fig. 3

The model, the version of the crane, the year of manufacturing and the serial number are stamped on the base (fig. 3) in the following sequence:

F330A.22*06*0100

serial no.
year of manufacturing
version / .23/ .24/ .26/ .27
model F330AC

(!) UNDER NO CIRCUMSTANCES SHOULD THE DATA MARKED ON THE PLATE AND PUNCHED ON THE BASE BE ALTERED.

It is essential to give the correct **crane model** and **serial number**, when you contact the Service and Parts Department.

The exact **crane model**, **serial number** and description of **implements** will enable FASSI Service Department to give a rapid and efficient response.

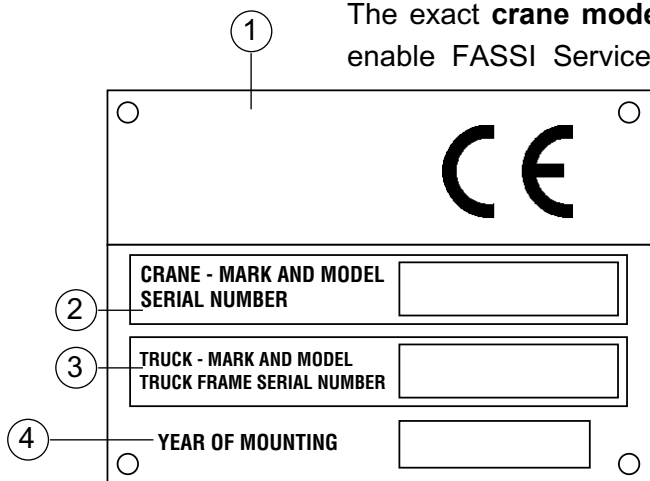

fig. 4

A further metallic plate (fig. 4) fixed to the crane by the installer, quotes the identifying data of the equipment and the final CE mark.

- 1 Name of the installer who applied the final CE mark
- 2 Crane mark, model and serial number
- 3 Vehicle mark, model and chassis number
- 4 Year of mounting

TECHNICAL DATA

The design of this crane has been carried out in respect of DIN 15018 norms, fatigue test classification **H1B3**.

The crane can operate, intermittently, with lifting devices other than the hook. The dimensions and the capacity of the implements must be proportioned with crane performances.

F 330A.23

Lifting capacity	Standard reach	Hydraulic extension	Rotation arc	Rotation torque	Working pressure	Pump capacity	Oil tank capacity	Crane weight	Max. working pressure on the outrigger (Φ 210)
31,7 tm 311,0 kNm	10,15 m	5,75 m	400°	5,33 tm 52,33 kNm	30 MPa	50 l/min	180 l	3910 kg	44 daN/cm²

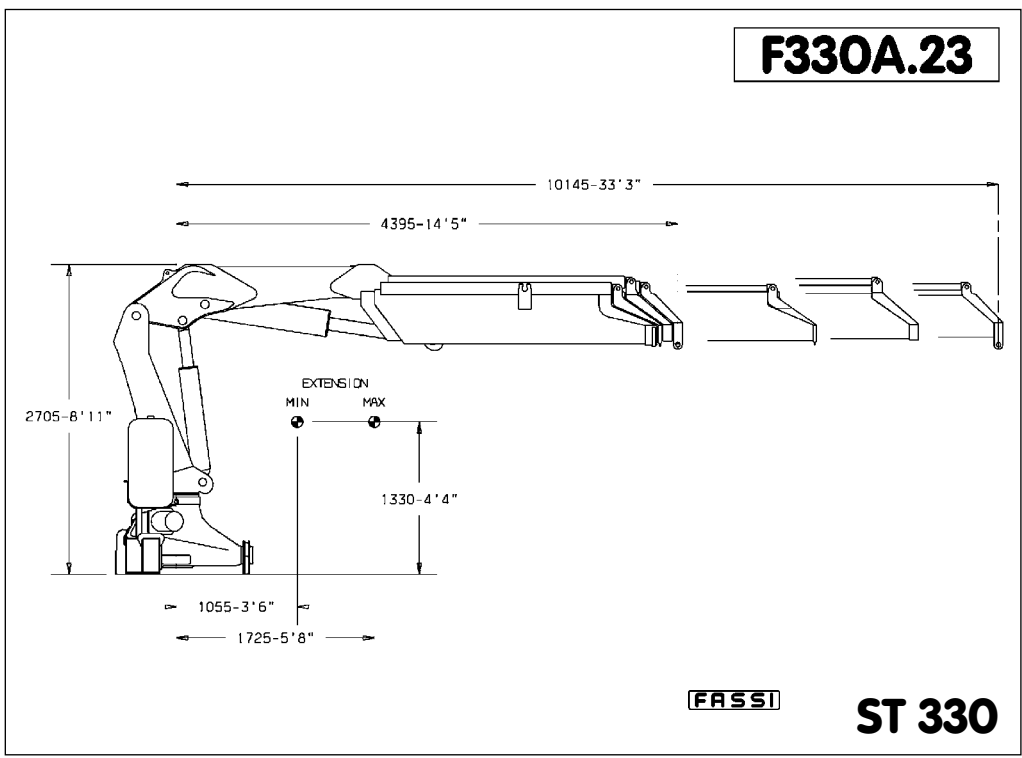

F330A.23

EXTRA	
A	2300 7' 7"
B	2300 7' 7"
C	2270 7' 5"
D	6870 22' 6"

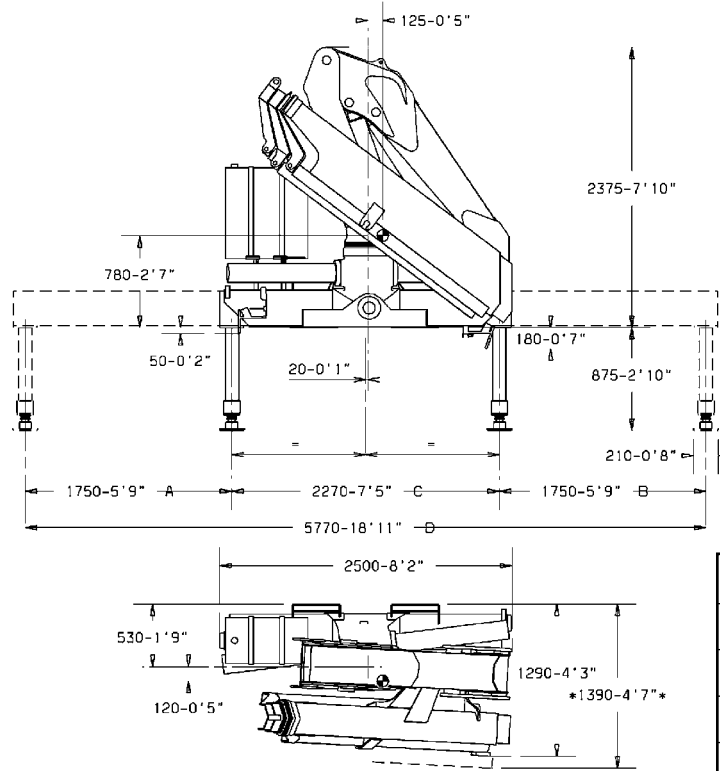

- ★ CON TUBAZIONI SUPPLEMENTARI
- ★ WITH SUPPLEMENTARY HOSES
- ★ AVEC TUYAUTERIE SUPPLEMENTAIRE
- ★ MIT ZUSAETZLICHEN SCHLAEUCHEN

PESI, DIMENSIONI E POSIZIONE BARICENTRO.
POIDS, DIMENSIONS ET POSITION DU BARYCENTRE.
WEIGHT, DIMENSIONS AND BARYCENTRE POSITION
GEWICHTE, ABMESSUNG UND POSITION DES KRANSCHWERPUNKTS.

- MEZZERIA TIRANTI
 - FIXING ROD CENTER DISTANCE
 - LIGNE MEDIANE TIRANTS
 - ABMESSUNG DER BEFESTIGUNGSBRIDEN
- N°4 M39 x 3
N°4 M33 x 2

PESO GRU CON SERBATOIO NON RIFORNITO, STABILIZZAZIONE STANDARD	kg 3.910
WEIGHT OF THE CRANE WITH EMPTY TANK, STANDARD STABILIZATION	
POIDS DE LA GRUE AVEC RESERVOIR VIDE, STABILISATION STANDARD	lbs 8.620
KRANGEWICHT MIT LEEREM TANK UND STANDARDABSTUETZUNGEN	

ST 330 FASSI

F330A

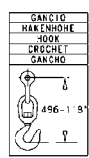
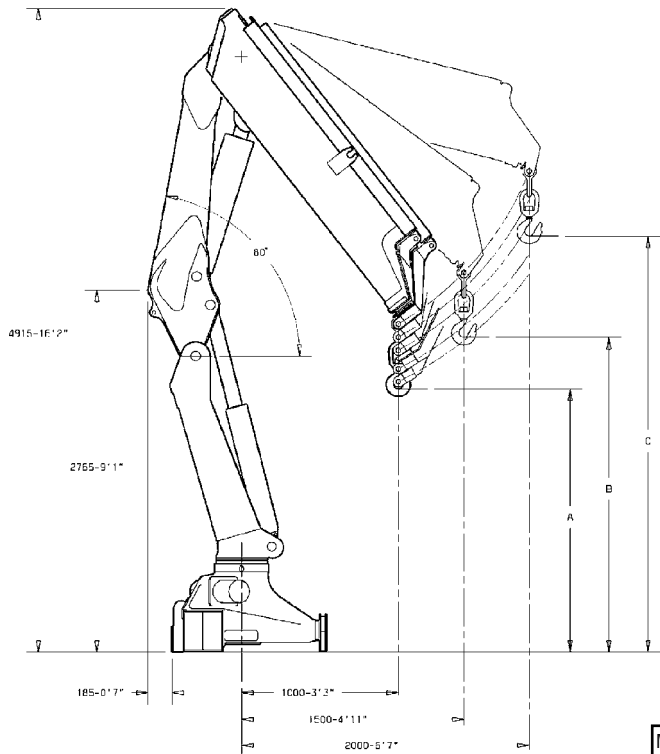

	A	B	C
F 330.22	201C 6'7"	2400 7'11"	3175 10'5"
F 330.23	191C 6'3"	2280 7'6"	2960 9'9"
F 330.24	181C 5'11"	2160 7'1"	2775 9'1"
F 330.26	166E 5'6"	1995 6'7"	2540 8'4"
F 330.27	157C 5'2"	1880 6'2"	2390 7'10"

MASSIMA ALTEZZA SOTTOGANCIO.
HAUTEUR MAXIMUM SOUS CROCHET.
MAXIMUM HOOKING POSITION.
MAXIMALHOEHE BIS KRANHAKEN.

FASSI ST 330

- Version with ground controls for crane and outriggers (fig. 5)
- Version with top seat controls (fig. 5a) for crane by hand cables (optional)

Pos.	Description
1	- Outrigger rams
2	- Outrigger supports
3	- Base
4	- Rotation cylinders
5	- Deviator crane - outriggers
6	- Outrigger multifunction deviator
7	- Outrigger multifunction transmission
8	- Distributor bank
9	- Double control
10	- Column
11	- Inner rams
12	- Inner boom
13	- Outer ram
14	- Outer boom
15	- Booms extension rams
16	- Extension boom sections
17	- Lifting hook
18	- Oil tank
19	- Manual extensions (optional)
20	- Seat (optional)
21	- Hand-cables for crane (optional)

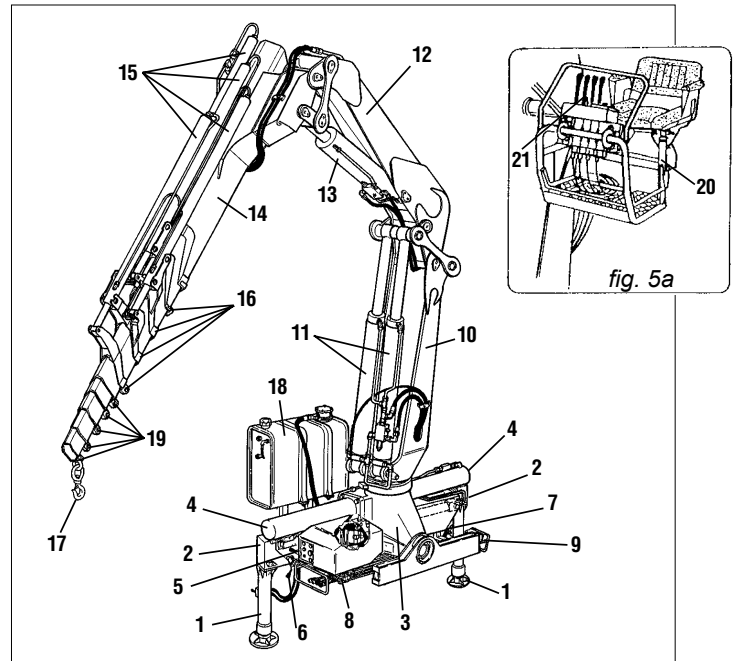

fig. 5

- Version with ground controls for outriggers and top seat controls for crane (fig. 6)

Pos.	Description
1	- Outrigger rams
2	- Outrigger supports
3	- Base
4	- Rotation cylinders
5	- Deviator crane - outriggers
6	- Outrigger multifunction deviator
7	- Outrigger multifunction transmission
8	- Column
9	- Seat
10	- Distributor bank
11	- Inner rams
12	- Inner boom
13	- Outer ram
14	- Outer boom
15	- Booms extension rams
16	- Extension boom sections
17	- Lifting hook
18	- Oil tank
19	- Manual extensions (optional)

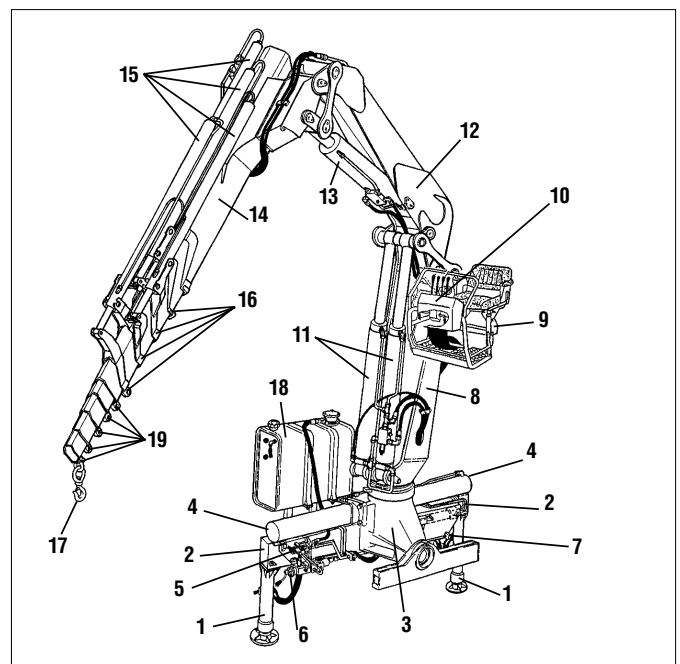

fig. 6

SAFETY AND PROTECTION DEVICES

- Version with ground controls for crane and outriggers
- Top seat controls (fig. 7a) for crane by hand-cables (optional) (fig. 7)

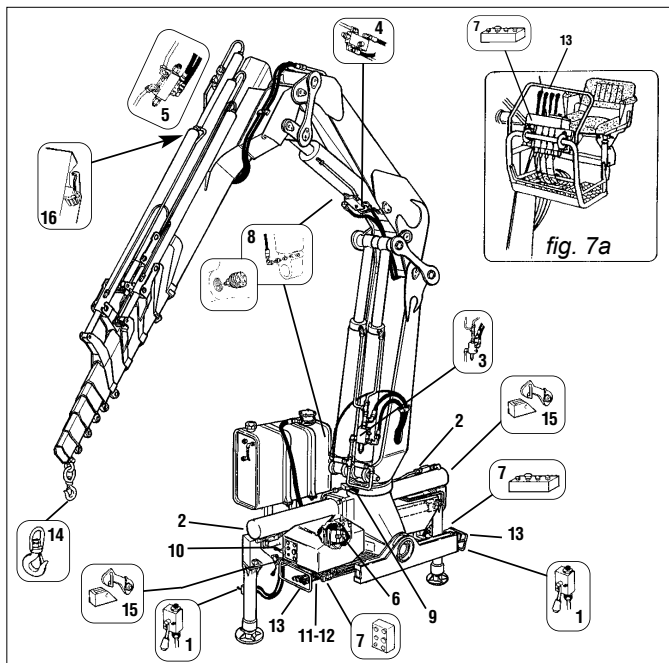

fig. 7

Pos.	Description
1	- Tap and check valve for outrigger rams
2	- Check valves for rotation control (flow regulators)
3	- Check valve for inner rams
4	- Check valve for outer ram
5	- Check valve for booms extension rams
6	- Lifting moment limiting device assembly
7	- Control panels
8	- Parachute valves
9	- Rotation limiting device
10	- Main pressure valve (outriggers - crane)
11	- Main pressure valve (crane)
12	- Auxiliary valves (crane)
13	- Levers guard
14	- Hook safety device
15	- Safety device for outriggers supports
16	- Safety device for extension booms (only for the crane version "C")

- Version with ground controls for outriggers and top seat controls for crane (fig. 8)

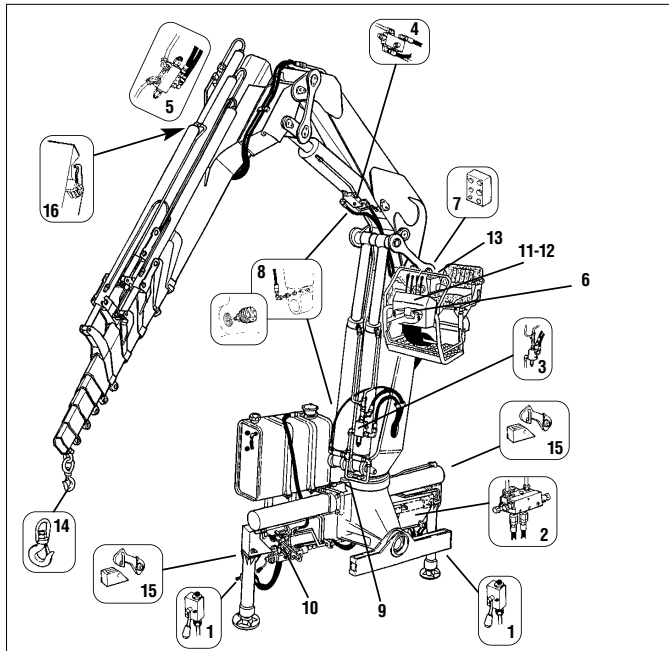

fig. 8

Pos.	Description
1	- Tap and check valve for outrigger rams
2	- Check valve for rotation control
3	- Check valve for inner rams
4	- Check valve for outer ram
5	- Check valve for booms extension rams
6	- Lifting moment limiting device assembly
7	- Control panel
8	- Parachute valves
9	- Rotation limiting device
10	- Main pressure valve (outriggers - crane)
11	- Main pressure valve (crane)
12	- Auxiliary valves (crane)
13	- Levers guard
14	- Hook safety device
15	- Safety device for outriggers supports
16	- Safety device for extension booms (only for the crane version "C")

(!) Before crane use check that safety and protection devices are fitted and active.

(!) Under no circumstances interfere with the safety and protection devices.

(!) Interference with the check valves and removal of the lead seals will invalidate the Manufacturers warranty.

(!) Use the ladder for the access to the top seat.

LIFTING MOMENT LIMITING DEVICE AND CONTROL PANELS

A characteristic which permits the classification of cranes is their lifting capacity or maximum lifting moment. The moment is defined by the value obtained from the product of the load to be lifted (in kg) by its distance (in meters) from the centerline of the crane rotation.

The device called "lifting moment limiting device" preserves the crane structure from overloads, as it prevents any movement which increases the value of the moment up to the maximum established value.

The lifting moment limiting device concerns the following manoeuvres:

- Inner boom descent; the inner boom lift is controlled by the general main pressure valve of the distributor.
- Outer boom lift.
- Outer boom descent.
- Extension of extension boom sections.
- Winch rope lift (if fitted).
- If hydraulic extension is fitted: extension outer boom lift.
- Extension outer boom descent.
- Extension of the jib extension booms section.

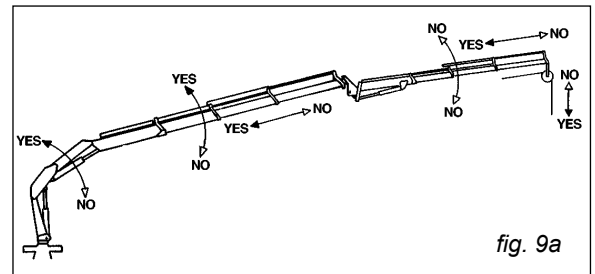

The crane configurations (fig. 9a-b-c) (and the eventual hydraulic extension) indicate the manoeuvres which are allowed and not allowed by the device, in connection with the horizontal position of the crane and extension outer booms.

Lifting moment limiting device "INTELLIGENT TYPE"

This device is fitted close to the distributor, whose specific functions it uses. It utilises an electrohydraulic technology, preventing any movement which causes an increase in the pressure induced by the load in the inner and outer rams of the crane (and in the outer ram for the hydraulic extension if fitted), up to the "critical values" which have been established in the structural test. These values, which are non-exceedable, determine the intervention levels and provide the data for setting the device.

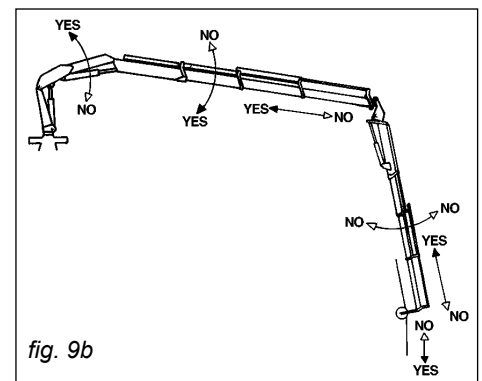

The device is based on hydraulic controls which are activated when the intervention value is reached and block the movements of the relevant distributor levers in one or both directions. Please remember that the device will return the lever of the element being used to neutral position. The condition of intervention is operated by the position of the outer boom (or, if hydraulic extension is fitted, the position of the extension outer boom), on which the electronic signal position (mercury level switch) is read by a special electrovalve. This determines the controls of the locking or unlocking (resetting) of the controls concerned.

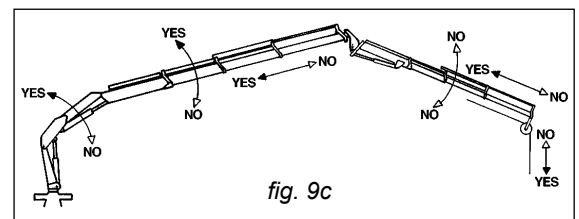

Lifting moment limiting device for two working areas

In case of one sector of the working area with no sufficient stability of the vehicle (e.g. sector in front of vehicle cab) the limiting device, by means of a special function, allows, using the rotation arc limiter as well as an adjustable electro-hydraulic device, to operate with a reduction of the intervention level.

The reduction of the intervention level reduces the crane capacity values and this reduction value is defined in the vehicle stability calculation.

Consequently the working area is divided in one sector (e.g. body side) where the crane works according to the capacity plate values and another sector (e.g. cab side) where it works with reduced capacity values.

The device has consequently two intervention levels which are activated in relation to the sector of the crane working area always securing the vehicle stability.

(!) ATTENTION (!)

If the rotation stops by going through the working zone where the crane can operate according to the capacity plate values to the one where it can operate according to the reduced values, it means that one of the following conditions is reached:

- manoeuvre of a load bigger than the one admitted in the reduced sector defined in the vehicle stability calculation
- manoeuvre without load with (at least) one of the inner, outer rams of the crane or the jib (if fitted) extended till the stroke end.

The only one allowed manoeuvre is the crane rotation in the reversed sense, and consequently, an action which respectively allows to reduce the moment or to re-enter the inner ram(s), the crane outer ram, the jib outer ram.

REACTIVATION button of crane functions and EMERGENCY exclusion tap of the lifting moment limiting device.

Firstly remove the protection guard. Then unscrew the three base fixing screws and the four seat fixing screws (13 mm hexagonal spanner).

REACTIVATION button of crane functions in the absence of the electric power.

- (!) On the distributor it has been installed an electro-valve with a manual locking function (fig.10-10a) which allows to reactivate all the crane functions in case of absence of the electric power. Only in these conditions it is permitted to remove the lead seals which protects the device. Push the button and turn it into the clockwise sense (fig. 10b pos. 1-2); the button stays in stable and closed position.
- (!) When the electric power is reestablished, remember to put the button in its original position, turning it into the anti-clockwise sense. (Fig. 10b pos. 3-4)

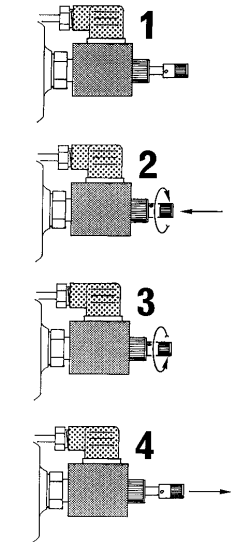

fig. 10b

Crane with ground controls

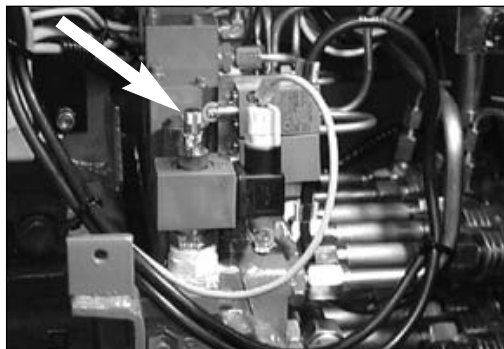

fig. 10

Crane with top seat control

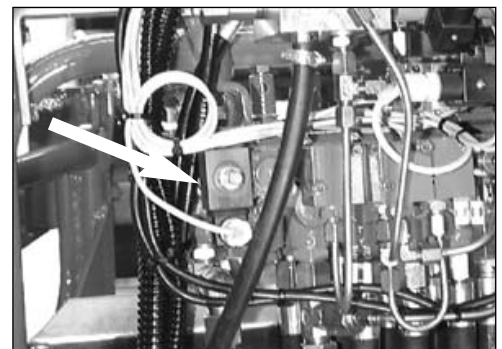

fig. 10a

EMERGENCY exclusion tap of the lifting moment limiting device

Every electro-valve is installed with a screwed tap (emergency exclusion tap), which must only be used in case of emergency, testing or other abnormal situations when it is not possible to carry out any of the movements allowed by the device. (This may occur when the extension booms are fully folded and the load is particularly heavy and bulky). Only in these situations it is permitted to remove the lead seals which protect the device. Slacken the lock nut of the screwed tap fig. 11-12 (14 mm hexagonal spanner), completely screw in the tap (5 mm allen key) and re-tighten the lock nut.

(!) WARNING (!)

When the operator uses this device, it means that he wishes to override the lifting moment limiting device in order to make some manoeuvres (which would be impossible with the device active) that bring the moment to within the maximum level, but involve an overload condition. In such an emergency condition (where the lifting moment limiting device has been disabled), the operator must:

- carefully consider the manoeuvres required to return to normal working conditions;
- calmly and carefully assess the type and scale of the hazards arising from these manoeuvres and the possible reaction of the crane (tipping over, frame overload, uncontrolled fall of the load due to a hydraulic system overload etc.);
- make all movements as slowly as possible to reduce the dynamic overload to the minimum.

Crane with ground controls

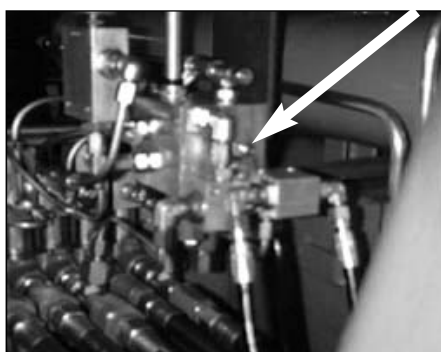

fig. 11

Crane with top seat control



fig. 12

After such emergency operations and prior to re-use of the crane, you must immediately go to FASSI authorised Center for testing the structure and re-sealing of the device.

(!) Interferences with the valves or removal of the lead seals release the Manufacturer from any responsibility and invalidate the warranty.

(!) ATTENTION (!)

The presence of the lifting moment limiting device does not release the user from the obligation to respect what is indicated on capacity plates and lifting curves.

LIFTING MOMENT LIMITING DEVICE (for DANFOSS Distributor, available on request)

This device is fitted close to the distributor, whose specific functions it uses. It utilises an electrohydraulic technology, preventing any movement which causes an increase in the pressure induced by the load in the inner and outer rams of the crane (and in the outer ram for the hydraulic extension if fitted), up to the "critical values" which have been established in the structural test. These values, which are non-exceedable, determine the intervention levels and provide the data for setting the device. The condition of intervention is operated by the position of the outer boom on which the electronic signal position (mercury level switch) is read by a special electrovalve. This determines the deactivation or the activation of the controls concerned.

When the moment is reduced, it resets automatically (the manoeuvres blocked by the device are released).

N.B.: There is a delay of 4 seconds after the moment reduction before the reset can occur in order to safeguard the stability of the device.

Lifting moment limiting device for two working areas

In case of one sector of the working area with no sufficient stability of the vehicle (e.g. sector in front of vehicle cab) the rotation limiting device, allows, by means of an adjustable electro-hydraulic device, to operate with a reduction of the intervention level of the lifting moment limiting device.

The reduction of the intervention level reduces the crane capacity values and this reduction value is defined in the vehicle stability calculation.

Consequently the working area is divided in one sector (e.g. body side) where the crane works according to the capacity plate values and another sector (e.g. cab side) where it works with reduced capacity values.

The device has consequently two intervention levels which are activated in relation to the sector of the crane working area always securing the vehicle stability.

(!) ATTENTION (!)

If the rotation stops by going through the working zone where the crane can operate according to the capacity plate values to the one where it can operate according to the reduced values, it means that one of the following conditions is reached:

- manoeuvre of a load bigger than the one admitted in the reduced sector defined in the vehicle stability calculation
- manoeuvre without load with (at least) one of the inner, outer rams of the crane or the jib (if fitted) extended till the stroke end.

The only one allowed manoeuvre is the crane rotation in the reversed sense, and consequently, an action which respectively allows to reduce the moment or to re-enter the inner ram(s), the crane outer ram, the jib outer ram.

EMERGENCY tap lever fig. 13.

Each device is fitted with an emergency tap lever to be used in the event of a black-out, electrical or hydraulic malfunctions or whenever the lifting moment limiting device makes it impossible to use any controls when handling a load (this may occur when the extension booms are fully folded and the load is particularly heavy and bulky).

(!) WARNING (!)

When the operator uses this device, it means that he wishes to override the lifting moment limiting device in order to make some manoeuvres (which would be impossible with the device active) that bring the moment to within the maximum level, but involve an overload condition. In such an emergency condition (where the lifting moment limiting device has been disabled), the operator must:

- carefully consider the manoeuvres required to return to normal working conditions;
- calmly and carefully assess the type and scale of the hazards arising from these manoeuvres and the possible reaction of the crane (tipping over, frame overload, uncontrolled fall of the load due to a hydraulic system overload etc.);
- make all movements as slowly as possible to reduce the dynamic overload to the minimum.

Only In these situations it is permitted to remove the lead seals placed on the tap lever and place it in the closed position.

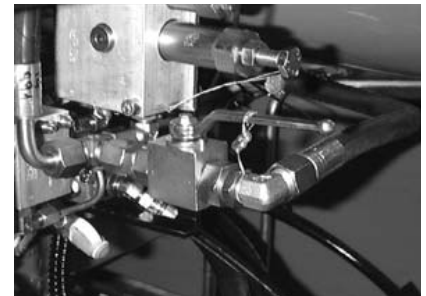

fig. 13

After such emergency operations and prior to re-use of the crane, you must immediately go to FASSI authorised Center for testing the structure and re-sealing of the device.

(!) Interferences with the valves or removal of the lead seals release the Manufacturer from any responsibility and invalidate the warranty.

(!) ATTENTION (!)

The presence of the lifting moment limiting device does not release the user from the obligation to respect what is indicated on capacity plates and lifting curves.

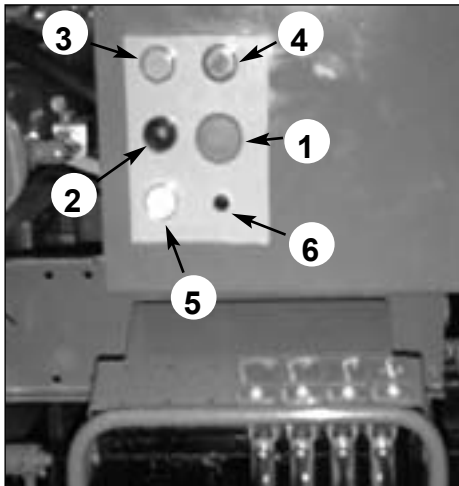

GROUND CONTROLS

fig. 14

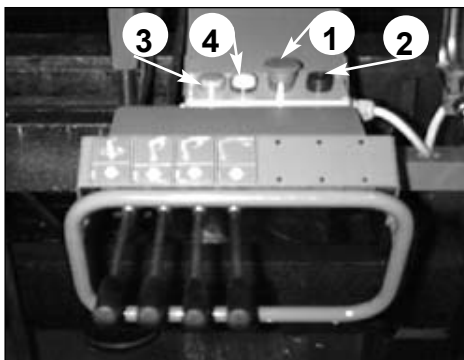

DOUBLE CONTROL SIDE

fig. 15

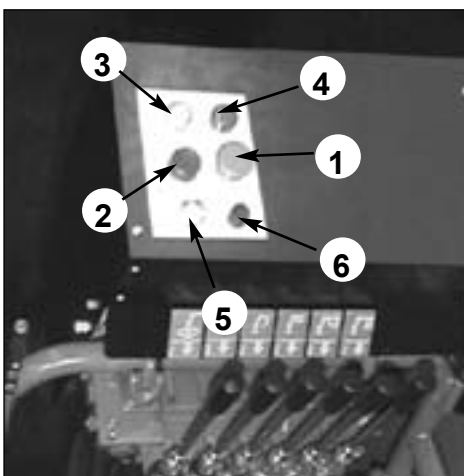

TOP SEAT CONTROLS

fig. 16

Control panels

The electric control panels are placed next to each control station.

Layout of the control panel (fig. 14-16), positioned next to the distributor

- pos. 1 — Stop button (STOP)
2 — Audible alarm push button (danger)
3 — Orange warning light (90% of the capacity has been reached)
4 — Red warning light (activation of the limiting device)
5 — White warning light (power on)
6 — Fuse

Layout of the control panel (fig. 15) positioned on the double control side in the version with ground controls and on top seat in case of hand-cable controls

- pos. 1 — Stop button (STOP)
2 — Audible alarm push button (danger)
3 — Orange warning light (90% of the capacity has been reached)
4 — Red warning light (activation of the limiting device)

If the white warning light 5 comes on, it confirms that the electric circuit is active.

!NOTE! In the absence of electric power all crane functions will be deactivated.

If the orange warning light 3 comes on during load handling, 90% of the capacity (lifting moment) has been reached.

If during operation the red warning light 4 comes on, the activation value of the lifting moment limiting device has been reached.

Any hidden danger situation for persons must be audibly alarmed by pressing the push button 2.

When there are serious, imminent and dangerous conditions for persons and things during load handling, operate on the stop button 1, which isolates all crane functions.

(!) ATTENTION (!)

Do not walk on the lever guards of the lifting moment limiting device positioned on the distributors or electric control panels.
Do not use water to extinguish fire!



DE 1679



DE 1680

ROTATION LIMITING DEVICE

When a sector of the working area exists in which the stability is insufficient (for example in the area in front of the cab) the permitted arc of rotation is limited by means of an adjustable electro-hydraulic device which only allows operation within the safe area. (Fig. 17)

When exceeding the "safe area" the rotation limiting device only allows manoeuvres which reverse the direction of rotation.

If a reduction of capacity is necessary because of insufficient stability of the complete unit, new capacity plates must be fixed giving the derated capacity in accordance with the final stability test.

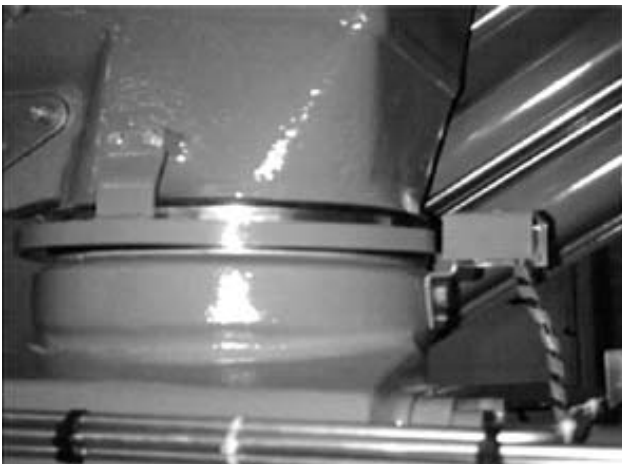

fig. 17

CONTROLS TO STABILIZE THE VEHICLE

The outriggers rams prevent harmful stresses both to the frame and to the vehicle suspensions on which the crane is mounted and assure the stability of the unit during load handling.

Supplementary beams

Supplementary beams (supplementary outriggers) are used in conjunction with the crane outriggers to ensure the vehicle stability during load handling. They are hydraulically extendable.

Supplementary beam code	outrigger ram stroke	extension max. integrals
330B055	340 mm	4984 mm hydraulic extension
330B054	520 mm	4984 mm hydraulic extension

Identification data of the supplementary beam are punched on the beam (fig. 18) in the following sequence:

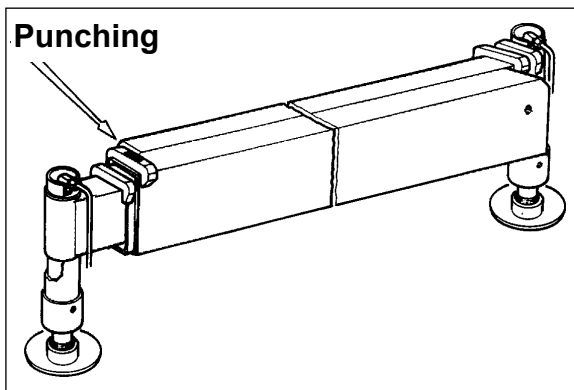

fig. 18

Example

330B055*0001

serial no.

identification code

! ATTENTION !

(!) The crane stability is only guaranteed by the maximum lateral extension of the outrigger supports of the crane and supplementary outriggers (if fitted).

Be very careful during vehicle stabilization operation; make sure that no one is or transits in close proximity of the working area of the outriggers.

Check that they are applied on a solid base; the maximum plate pressure of the rams is:

44 daN/cm² on a plate which diameter is 210 mm

If needed use the special base plates (on request).

When stabilization is complete the wheels of the vehicle must still be in contact with the ground and the suspensions must not be fully unloaded.

Level the crane so as to operate on a horizontal plane.

The crane is supplied with outrigger supports having hydraulic side extension. (On request hydraulic extra extendable supports).

The controls to stabilize the vehicle are activated only on ground level and on both sides of the crane base.

(!) The controls to stabilize the vehicle are in conformity with the safety directives and enable the operator to activate the lateral extension of the outriggers (outrigger supports and rams) only from the side where he can visually check the operation.

The special construction concept of the outrigger control group which combines the functions of an 8 positions deviator with those of a distributor segment, allows to use the control lever for selecting and operating the supports and the outrigger rams.

- The selection (support or ram) is effected, like on a deviator, by positioning the lever on the corresponding position indicated by the function schematic (plates DE2345 and DE2346) placed on the controls.
- The control is effected by operating the lever like on a distributor; the stability of the selected position is guaranteed by an internal device.

The extension and re-entering of the support and outrigger rams indicated in the fig. 19-19a coincide with the plates DE2345 and DE2346 placed in dual side position on the base.

The symbols reported at side of each lever indicate the operating levers in relation to their movement.

Lever function D - C

- Lever **D** Deviator crane - outriggers (⊗ - E/S). Fig. 20a-20b
- Lever **C** Multifunction deviator for selecting and operating the supports and the outrigger rams of the crane as well as the supplementary outriggers. Fig. 20-21

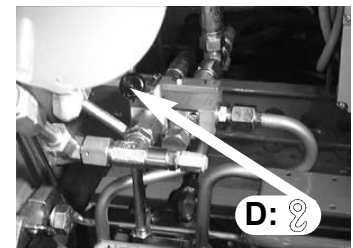
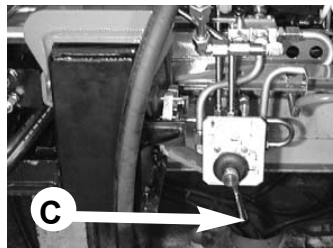

fig. 20a

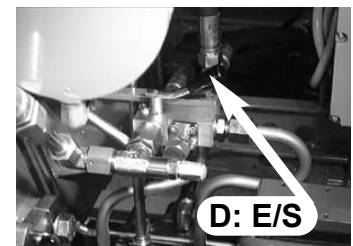

fig. 20b

Control for outrigger support extension for the crane and the supplementary outriggers.

- Position lever **D** of oil diverter crane-outriggers (⊗ - E/S) on **E/S**. Fig. 20b
- Open all the taps of the valves placed on the outrigger rams fig. 22.
- Disengage the locking devices of the outrigger supports by putting the levers **A** from the position of the fig. 23 to the one of the fig. 23a.

Crane distributor side DE2345 fig. 19-20.

- Select the outrigger support **E2** positioning the lever **C** of the multifunction deviator on **E2**.
- Operate the lever to extend the support **E2**.
- Select the outrigger ram **S2** positioning the lever **C** on **S2**.
- Operate the lever to control the ram descent **S2**.

Distributor side fig. 19

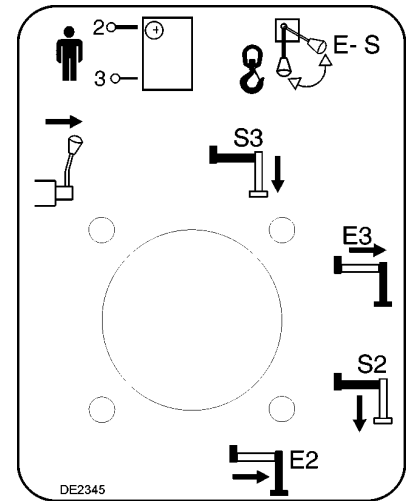

Double control side fig. 19a

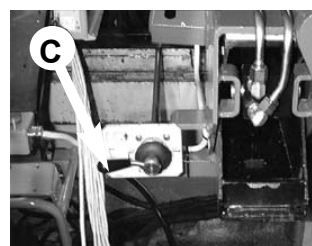
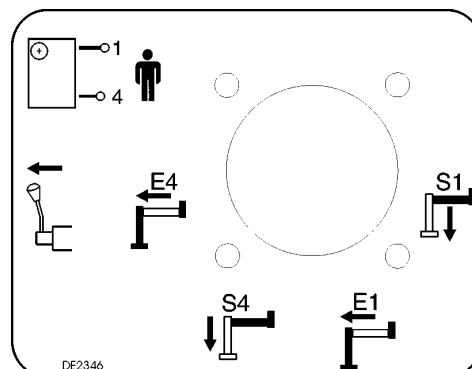

fig. 21

- Select the support **E3** positioning the lever **C** on **E3**.
- Operate the lever to extend the support **E3**.
- Select the ram **S3** positioning the lever **C** on **S3**.
- Operate the lever to control the ram descent **S3**.

N.B. The lever, if in other positions, does not allow any operations as a security device keeps it in free position.

Crane double control side **DE2346** fig. 19a-21

- Select the support **E1** positioning the lever **C** on **E1**.
- Operate the lever to extend the support **E1**.
 - Select the ram **S1** positioning the lever **C** on **S1**.
 - Operate the lever to control the ram descent **S1**.
- Select the support **E4** positioning the lever **C** on **E4**.
 - Operate the lever to extend the support **E4**.
 - Select the ram **S4** positioning the lever **C** on **S4**.
 - Operate the lever to control the ram descent **S4**.

N.B. The lever, if in other positions, does not allow any operations as a security device keeps it in free position.

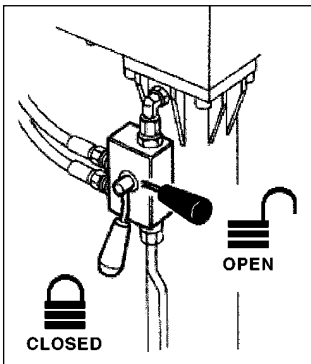

fig. 22

(!) ATTENTION (!)

During the stabilisation operations, for each outrigger ram, it is recommended to **DESCEND** the outrigger as the last manoeuvre.

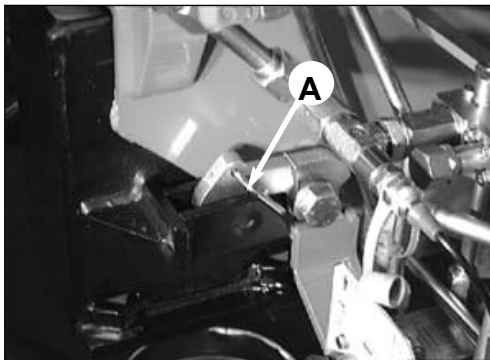



fig. 23

(!) ATTENTION (!)

The complete extension of the outrigger supports is visually indicated by the yellow triangles which are found at the end of the beam. (Fig. 23b)

The stabilization has to be carried out with care and gradually keeping the vehicle in horizontal levelled condition to prevent spring overloads and chassis twisting.

After having completed the descent and stabilisation manoeuvres, close the taps of the valves placed on the outrigger rams.

- Unfold the crane into a working condition, positioning lever **D** of oil diverter crane-outriggers ( - **E/S**) on  **E/S**. Fig. 20a

Manoeuvres for re-entry of the crane outriggers and supplementary outriggers within the overall vehicle width after crane use.

- Position lever **D** of oil diverter crane-outriggers ( - **E/S**) on **E/S**. Fig. 20b

- Open all the taps of the valves placed on the outrigger rams (fig. 22).

(!) WARNING (!)

Under no circumstances put the hands on the locking devices of the outrigger supports; the device re-hook (lever **A** from position of fig. 23b to fig. 23) is automatic.

Crane distributor side

- Select the outrigger ram **S2** positioning the lever **C** on **S2**.
- Operate the lever to control the re-entry of the ram **S2**.
- Select the outrigger support **E2** positioning the lever **C** on **E2**.
- Operate the lever to control the re-entry of the support **E2**.
- Select the ram **S3** positioning the lever **C** on **S3**.
- Operate the lever to control the re-entry of the ram **S3**.
- Select the support **E3** positioning the lever **C** on **E3**.
- Operate the lever to control the re-entry of the support **E3**.

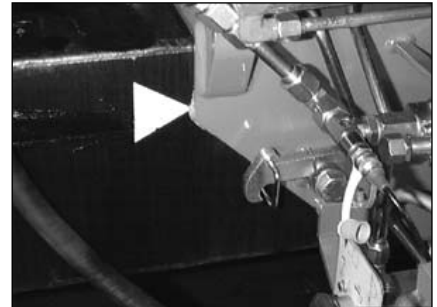

fig. 23b

NB The lever, if in other positions, cannot be operated as a safety device keeps it in neutral position.

Double control side

- Select the ram **S1** positioning the lever **C** on **S1**.
- Operate the lever to control the re-entry of the ram **S1**.
- Select the support **E1** positioning the lever **C** on **E1**.
- Operate the lever to control the re-entry of the support **E1**.
- Select the ram **S4** positioning the lever **C** on **S4**.
- Operate the lever to control the re-entry of the ram **S4**.
- Select the support **E4** positioning the lever **C** on **E4**.
- Operate the lever to control the re-entry of the support **E4**.

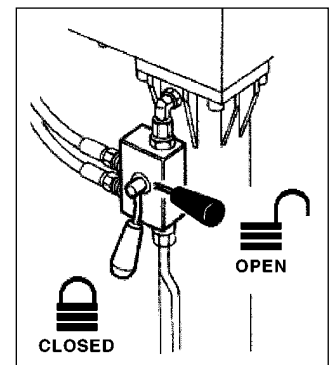

fig. 22

NB The lever, if in other positions, cannot be operated as a safety device keeps it in neutral position.

(!) Always check that the outriggers supports, once in their rest position, are locked in their seat by the safety devices, so as to assure the impossibility of accidental movement. (Fig. 23)

(!) It is compulsory to close the outriggers rams valves taps before moving the truck. (Fig. 22)

Tiltable outrigger rams (optional) (fig. 24-24a).

Outrigger rams which allow to be rested in an inclined position, when obstructions on the vehicle chassis prevent their vertical stowability. After the extension of the lateral outrigger supports, place the outrigger ram in a working condition as follows:

- Remove the check pin and then the locking pin (fig. 24) from its seat.
- Rotate the outrigger ram in a down direction, re-insert the locking pin in the new seat (fig. 24a) and lock it with the security pin.

- (!) **The locking pin is constructed from special material**
- do not replace it with a non original part
- your security depends on it



fig. 24

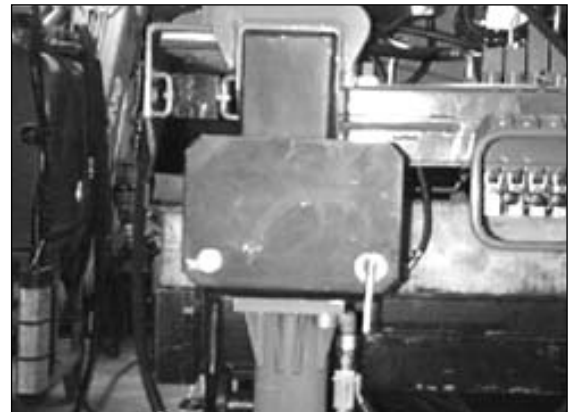

fig. 24a

(!) WARNING (!)

Before operating the crane it is compulsory to set the outriggers and to shut the safety check valve taps.

This coincides with that indicated on the plate **DE319** placed on the outriggers (fig. 25).

- (!) **Operate the levers smoothly and gradually.**
When carrying out simultaneous movements of two or more functions, also related to pump flow and lever travel, it is possible that on reaching the stroke end of a particular function, an increase in speed of the other functions will occur.

(!) WARNING (!)

While exiting and folding the crane, you must operate from the distributor side; it is forbidden to operate from the double control side because of the overall dimensions of the booms. (DE1684A fig. 30)

The symbols placed over each lever define their function in relation to their movement.

The crane and hydraulic implements can be operated with:

- manual controls (distributor and double control) placed on the base;
- manual controls (distributor) placed on the top seat;
- manual controls (distributor and double control) placed on the base and hand-cable controls placed on the top seat.

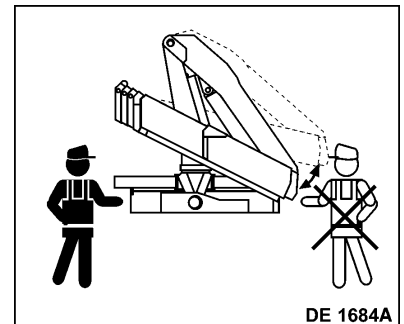

fig. 30

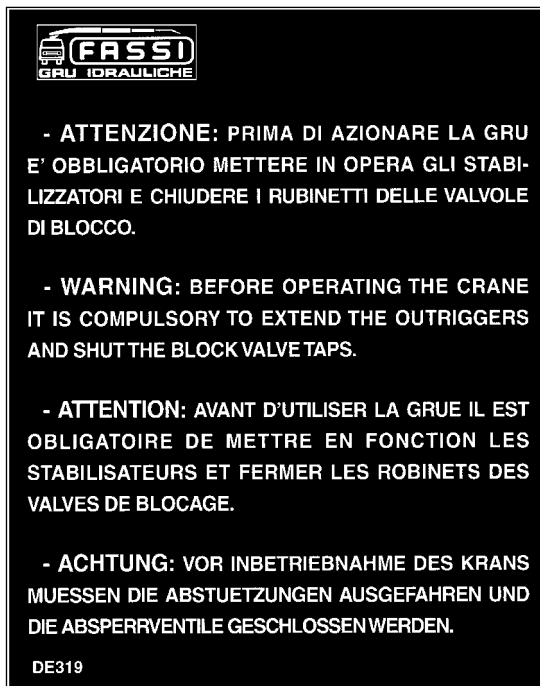

fig. 25

Crane controls - Lever function F - G - H - I (fig. 26-27-28)

- F** - Rotation control
- G** - Inner ram control
- H** - Outer ram control
- I** - Outer booms section rams control

Distributor side

fig. 26

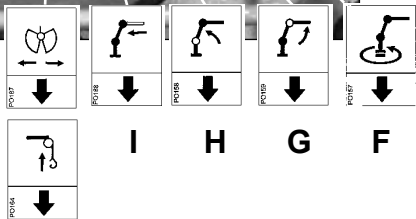
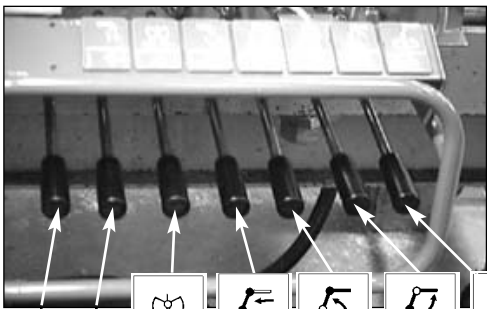

Hydraulic implements controls

Lever function

L - M - N
(fig. 26-27-28)

L — First hydraulic implement control.

M — Second hydraulic implement control.

N — Third hydraulic implement control.

Double control side

fig. 27

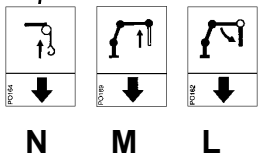
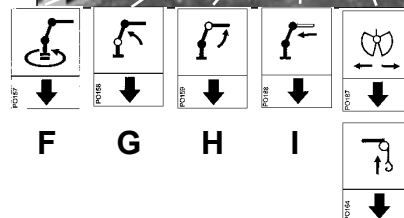
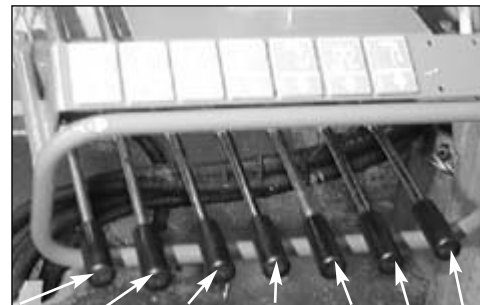

Always remember that the number of levers for hydraulic implements controls changes upon the type of fittings, as follows:

- 1 lever Winch or bucket control
- 2 levers Rotator - bucket or jib outer ram - jib extension rams control
- 3 levers Jib outer ram - jib extension rams - winch control

From top seat

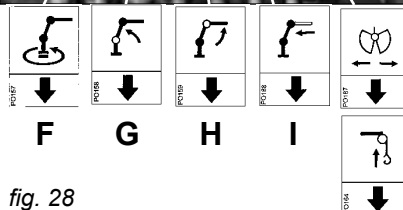
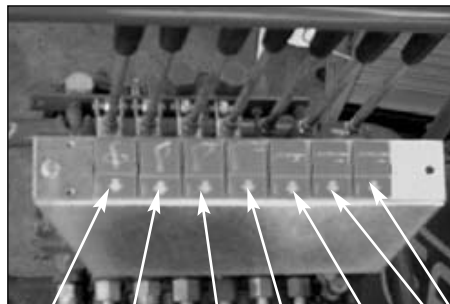

fig. 28

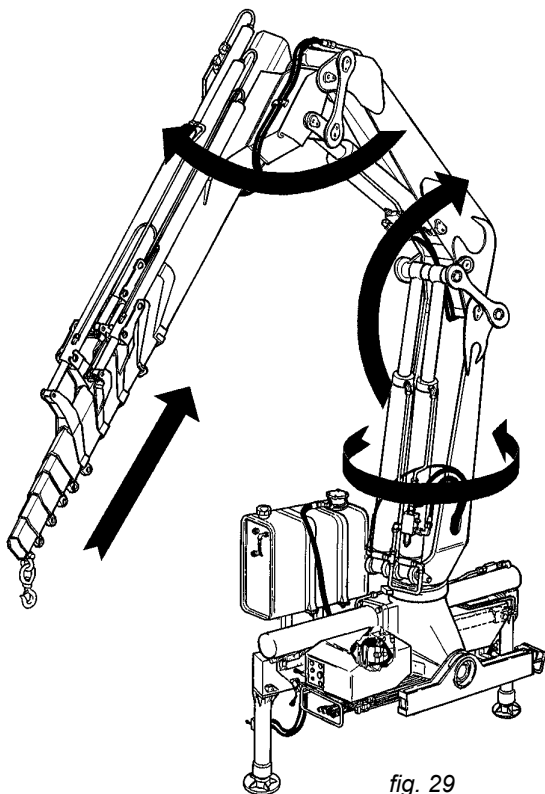
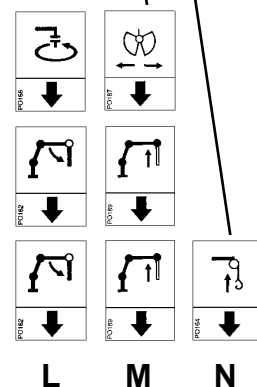

fig. 29

Manoeuvres to unfold the crane into a working condition (fig. 29)

- Engage the power take off.
- Stabilize the vehicle as described on page 16.

(!) IT IS FORBIDDEN TO OPERATE FROM THE DOUBLE CONTROL SIDE (!)

(!) Operate from ground control distributor side (!)

- Operate the lever **I** (re-entry) to ensure that the extension booms are re-entered.
- Before lifting the inner boom, be sure that the outer ram is closed (operate the lever **H** re-entry function).
- Lift the inner boom over the horizontal line, by operating lever **G** (fig. 30).
- Open the outer boom to the “horizontal” position by operating lever **H**.
- (Eventually) extend the booms of the crane by operating lever **I**.
- Position the hook on the vertical line above the load, operating lever **F** (rotation).

Manoeuvres to fold the crane into the rest condition

(!) IT IS FORBIDDEN TO OPERATE FROM THE DOUBLE CONTROL SIDE (!)

(!) Operate from ground control distributor side (!)

- Fold the extension booms to their stroke end.
- Lift the inner boom to its stroke end.
- Fold the outer boom to its stroke end.
- Operate the rotation control until the arrows placed on the base and on the column (dust cover) coincide.
- Fold the inner boom to its stroke end; the rest locating pin locates into its seat (fig. 30).
- Lift and re-enter the outriggers to within the overall vehicle width as described at page 16.

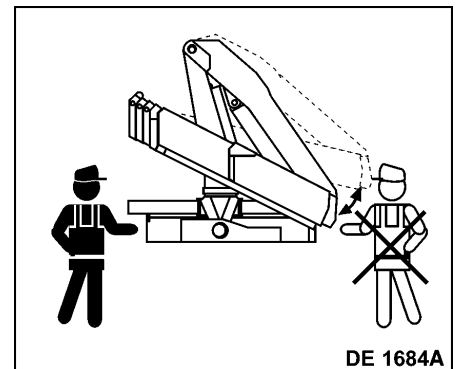

fig. 30

Load manoeuvres

- (!) Before manoeuvring the load, verify that the working area is suitable for your crane.

When a sector of the working area exists in which the stability is insufficient (for example in the area in front of the cab) the permitted arc of rotation is limited by means of an adjustable electro-hydraulic device which only allows operation within the safe area. When exceeding the "safe area" the rotation limiting device only allows manoeuvres which reverse the direction of rotation. The lifting curves of the capacity plate indicate the maximum load that the crane can lift at a certain radius and at a certain height.

To utilize the maximum capacity of the crane, it is necessary to position the inner boom as indicated on the capacity plate; the coloured symbols on the inner boom and column must coincide.

During load handling, do not exceed the reach limits given, or the load indicated on the above mentioned charts.

If the limits are exceeded, the load limiting device, allowing all manoeuvres, which reduce the lifted load within the permitted reach limits and forbid all other manoeuvres, will be immediately activated.

- (!) The presence of the lifting moment limiting device does not release the user from the observance of the capacity plates and lifting curves.

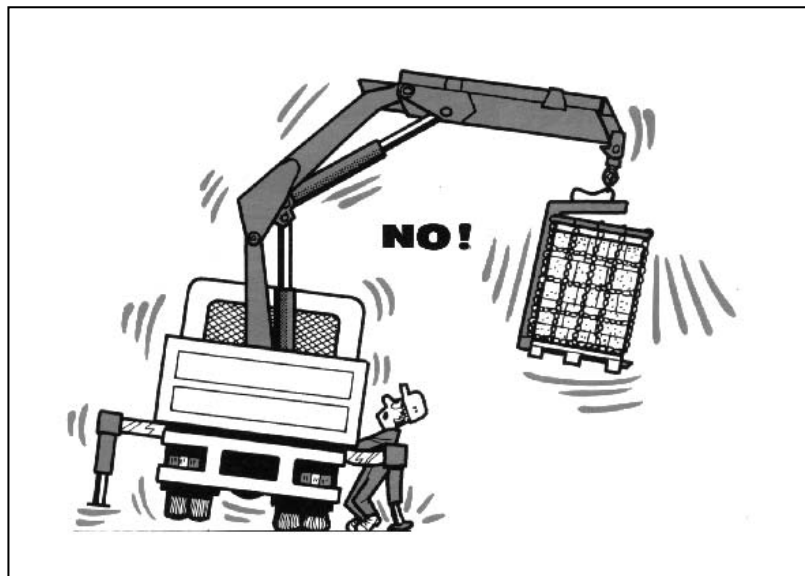

USE OF IMPLEMENTS

The crane can be provided with implements such as:

- Manual extensions
- Winches
- Hydraulic extensions
- Personnel baskets.

(!) When using an implement it is always necessary to check that its weight, dimension and capacity is matched to the crane performances.

Warning and norms for crane use also apply for hydraulic implement use.

(!) Before using a personnel basket it is necessary to provide the crane with the safety devices requested by the local norms in force. Prior to use of the crane it has to be tested and inspected in accordance with the local legal requirements.

Manual extensions

Manual extensions are additional boom sections, which are placed in the crane outer booms and secured by pins and check pins; they have a maximum capacity, indicated on the plate, independent from the crane configuration.

! WARNING !

**Manual extensions are not protected by the lifting moment limiting device.
 Before lifting the load make sure that its weight does not exceed the capacity indicated on the plate.**

Manual extensions can be extracted from the rest position and be operative, once the security pins have been removed, with the outer boom in sliding position.

(!) Verify that the area is suitable for this operation and there are no unauthorized persons in the working area.

Do not permit the extension to slide out at speed as this will damage the stroke end stops.

Do not try to align the holes (slots) for the locking pins with your fingers; always use a suitable tool.

Always remember that when operating with implements, their tare weight must be deducted from the capacity of the crane.

When manual extensions are in place, fit the check pins and secure them with the check pins to prevent accidental escape.

Winch (fig. 31)

The winch is made of a drum (pos. 1) that can rotate by means of a hydraulic motor (pos. 2), on a structure (pos. 3) fixed on the crane (i.e. under the outer boom). The rotation of the drum on which the cable winds is achieved by a hydraulic motor (pos. 2) connected to the circuit by means of hoses; in the case of fittings or hose failure the stop of the rotation is guaranteed by a safety check valve (pos. 4). A parking brake integrated into the moto-reducer group prevents the rotation of the drum (holds of the winch load in position), when the control function is not activated (lever **N** in neutral position).

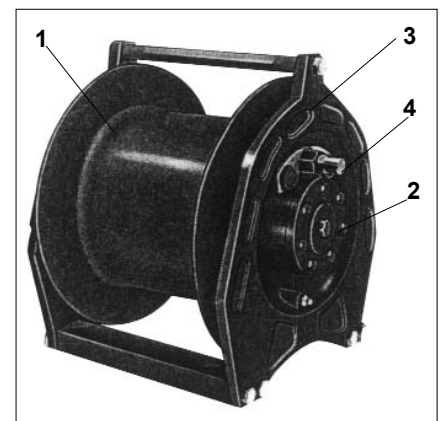
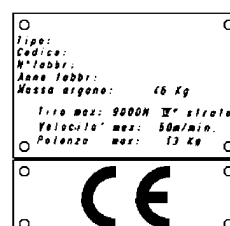

fig. 31

The winch is identified by a plate (fig. 31a) indicating the essential data and fixed by the manufacturer:

- Manufacturer mark ...
- Winch type ...
- Serial number ...
- Maximum line pull in N at the 4th layer...
- Maximum speed in m/min ...



(!) See operator winch manual supplied by the winches' manufacturer.

fig. 31a

The winch has a maximum capacity, indicated by a plate, not related to the crane capacities which can also be lower.

Consequently avoid to lift, with the winch, heavier loads than those allowed by the crane capacity plate.

The couple limiter, installed on the winch structure, prevents that on the cable, can be created a load major to the value of maximum line at the 4th layer, quiescing all the crane controls.

(!) Under no circumstances interfere with the limiter device adjustment.

Do not rotate the crane before the load is lifted, rotate slowly and with care the suspended load checking the stability of the vehicle.

The presser-cable always keeps the cable in tension easing the regular rewinding and without overlappings on the drum.

(!) On winches not equipped with presser-cable, check the rewinding of the cable on winch drum proceeds regularly and without overlapping: it is suggested not to rewind the cable if it is not sufficiently taut.

According to the actual norms the winches must be provided with a safety device. The adopted one uses electrohydraulic technology, where a signal, given by a microswitch, controls the stopping and the reactivation of crane controls through an electrovalve.

The adopted device prevents that:

- when the lifting with the winch or the exit of the extension rams (crane or hydraulic extension) the cable hook (or the block) takes contact with the pulley structure;
- when unwinding the cable is completely unwound from the winch drum (three turns must be wound at least), causing the controls to stop.

To reactivate the controls the lever (fig. 26-27-28), winch control must be activated controlling:

- the descent of the cable if the device has been operated by the lifting with the winch or in exit with the booms extension rams;
- the lifting of the load if the cable has been unwound too far.

In the phase of lifting or exit of booms extension rams, the control of the position of the cable hook (or the block), as regards the pulley structure, is obtained through a microswitch, which lever is kept in position by a chain balance weight, assembled free on the cable.

In the stopping of the crane the keeping in position of the microswitch lever becomes impossible with the constant operation of the controls.

To put the crane in the rest position it is necessary to operate in this way:

- withdraw the flying drive (it is assembled on the cable of the cable winder) from the pin placed near the microswitch, placed on the pulley, assembled on the booms extension rams.
- In case it is a crane with hydraulic extension it is necessary to detach the cable of the cable winder, placed on the crane from the pin of the second cable winder, assembled on the extension.
- Release the cable from all support rings placed on the booms letting it winds free in the cable winder.
- Insert the flying drive in the pin placed in the cable winder. (Fig. 32).

This operation activates all crane controls to complete the rest position operations.

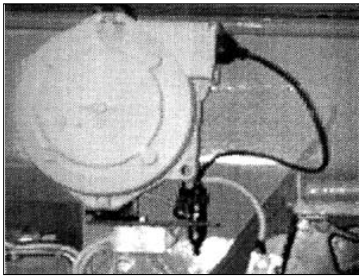

fig. 32



fig. 33

(!) Please remember that after stabilizing the vehicle and placing the crane in the working position it is compulsory to reset the functional end stroke device, otherwise the cable could be damaged.

Hydraulic connections between implements and hoses fitted on extension booms section. (Fig. 33)

(!) In case of hoses connection to implements through coupling unions it is necessary to verify that there is no trace of soil, dirt etc. on the unions and inside the seats so as to avoid the oil contamination and consequently wear of the tightening " surface of the unions.

(!) WARNING (!)

To ensure that the control corresponds to the implement movement, hydraulic connections are symmetrically fitted with coupling unions. Never invert such positions: movements inversion as well as operating difficulties could occur.

MAINTENANCE INSTRUCTIONS

To assure a long life to the crane, it is necessary to meticulously follow the instructions.

General lubrication and small repairs can be carried out by the user; repairs of a more complicated nature must be carried out by authorized service personnel.

Spare parts must be original.

Good maintenance and proper use are imperative to maintain efficient use and guarantee the safety of the crane.

At least once a year you must take the crane to a Fassi Service Center for a check.

(!) Before disconnecting any hydraulic hoses, ensure that there is no pressure in the hydraulic circuit. After removing hoses always mark them and their respective ports on the crane. Faulty replacement can cause damage to the rams and to the hydraulic circuit.

Respect the information supplied for maintenance and technical assistance.

Any maintenance operation must be carried out with the crane power source turned off. (in case of fixed mounting with hydraulic power pack, the electric motor has to be turned off).

Do not place limbs, fingers or any other parts of anatomy into areas of the crane, which present possibilities of shearing, without having blocked such parts of the crane.

Do not weld, drill or grind any part of the crane without the Manufacturer's authorization.

Do not weld the fixing rods of the crane (see plate DE1574 fig. 35).

When repairs to, or checks of, the hydraulic circuit and of the rams are carried out, it is very important not to use, or be in the proximity of, materials which can damage the circuit or contaminate the hydraulic oil eg. metal shavings, sand or dust.

Do not use the high pressure washing on the controls (deviators, distributors, double controls, hand cable controls...), on the electronic components (boxes, control panels...), on the tanks.

Never use detergents, petrolsol or inflammable liquids, always use non flammable or non toxic liquids.

To avoid down time, it is recommended to periodically carry out the following checks.

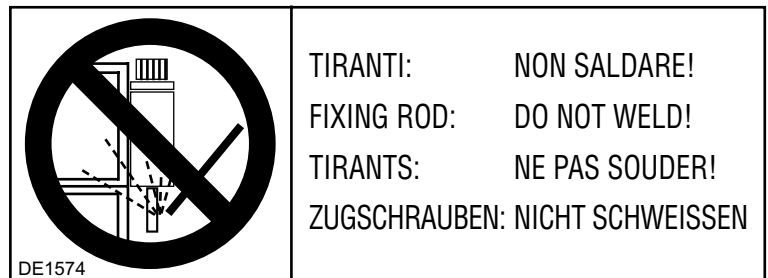

fig. 35

At the end of every working day

Check that all safety devices are efficient.

Check the level of the hydraulic oil in the tank.

Check the hoses fittings and all the components of the hydraulic circuit for possible leaks.

Check that the oil diverter levers can easily be positioned and that the multifunction control levers of the crane operate freely and return to neutral position.

Check that the control levers of the crane can easily be positioned (distributor, double controls and hand-cables) operate freely and return to neutral position.

Check the condition of shackles, hooks, wire ropes and any other lifting equipment.

After the first 40 hours use

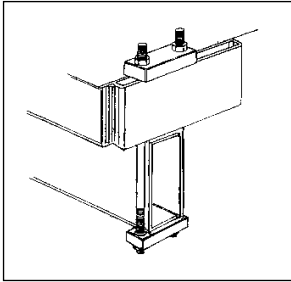

fig. 36

Check the tightening torque of the fixing rods of the crane. (Fig. 36)

Tightening torque for the rods pendulum beam side M 33x2 = 1200 Nm
Tightening torque for the rods stabilizers side M 39x3 = 1800 Nm

After every working week

Clean the oil filter placed in the oil tank of the crane and if any, on the pump section and pressure hoses.

If the hydraulic circuit of the crane is connected to a tipper a remote oil tank may be fitted, in this case the filter will be found in this tank.

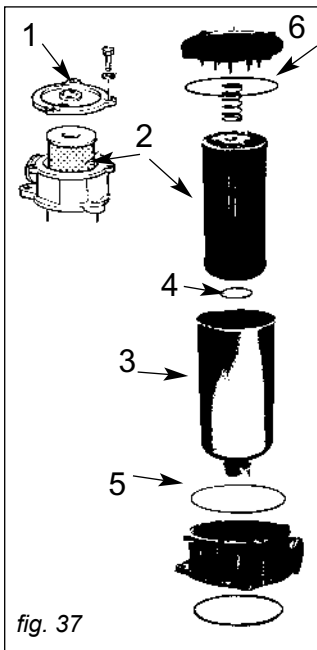

fig. 37

Cleaning of the filter on the tank (oil return from the distributor) fig. 37

- Remove the filter cover, pos. 1, by unscrewing the three security bolts. Remove the spring and extract the filter cartridge pos. 2: during this operation take care that no contaminated material passes into the tank.
- Clean the cartridge by flushing with a non flammable and non toxic solvent. Thoroughly dry the filter inside and out with compressed air.
- Remove the filter holder from the filter body pos. 3 (a hose is attached to its base); clean and reassemble checking the sealing 'O' rings pos. 4-5 (internal seal between cartridge and holder and external seal between holder and body).
- Re-assemble the filter cartridge into its holder, re-assemble the spring and the filter cover pos. 6 (check the sealing of the 'O' ring under the filter cover).
- Re-fit the three security bolts.
- Check for leaks when the pump is activated.

Check the oil level in the tank with the crane in the folded position and with the outriggers (crane and supplementary) fully re-entered. The oil level must not exceed the maximum or be lower than the minimum (fig. 38).

Top up using hydraulic oil with the same characteristics as those indicated in the table on page 41.

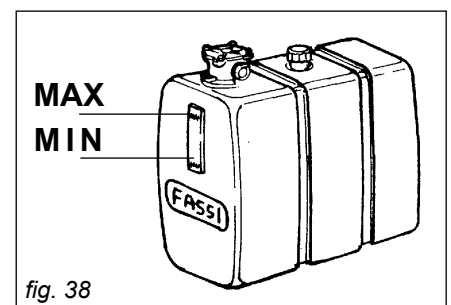
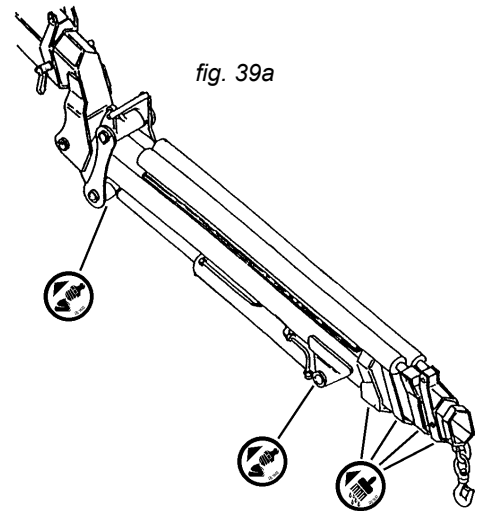
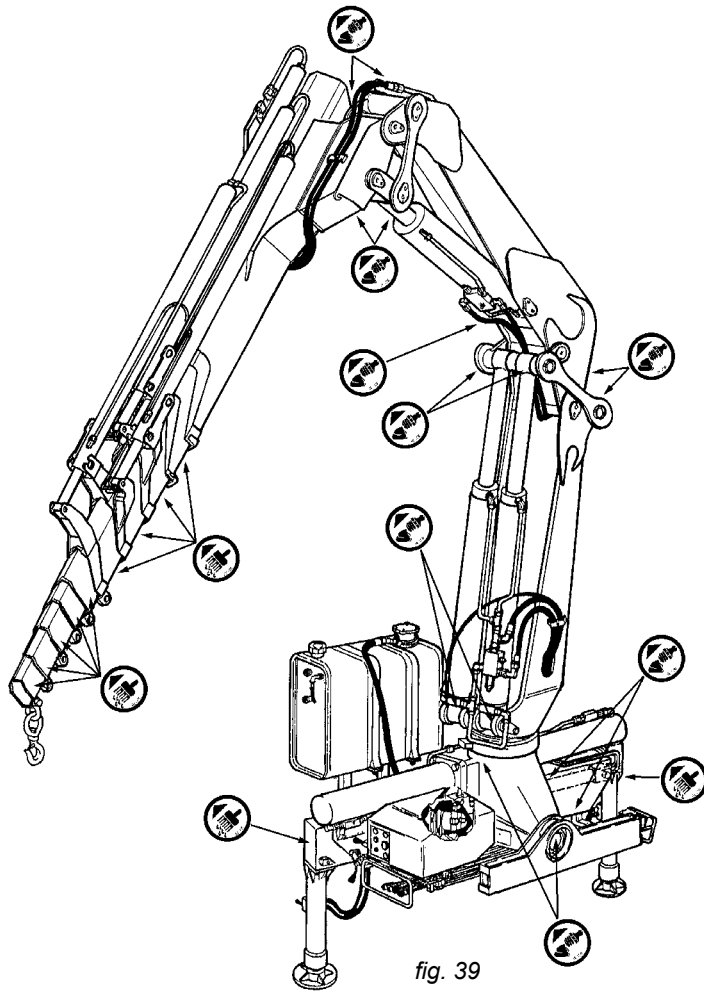

fig. 38

Periodically grease the points indicated on the crane (fig. 39) (and on the hydraulic jib, when fitted, fig. 39a) paying particular attention to the points not easily detected.



- Fig. 40 shows the guide shoe lubricator for the column rotation.
- Fig. 41-41a-41b-41c show the lubricators of the column symmetrically positioned on the column support.

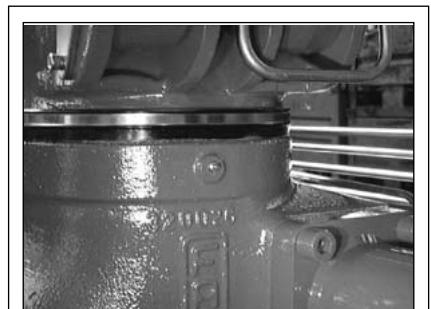

fig. 41b



- Fig. 42 shows the lubricator of the pendulum beam.
- Fig. 43-43a-43b-43c show the lubricators of the inner rams - outer ram and of fork / connecting rod assemblies.

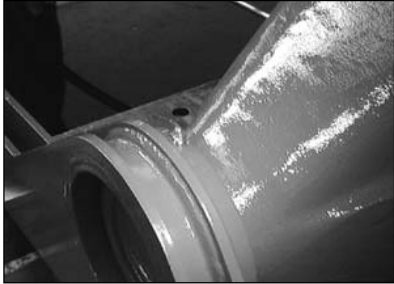

fig. 42

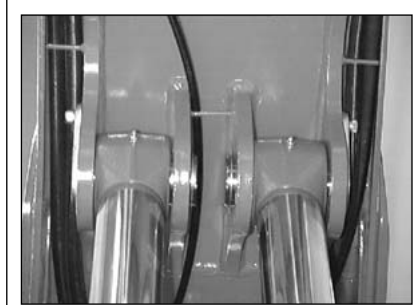

fig. 43a

fig. 43

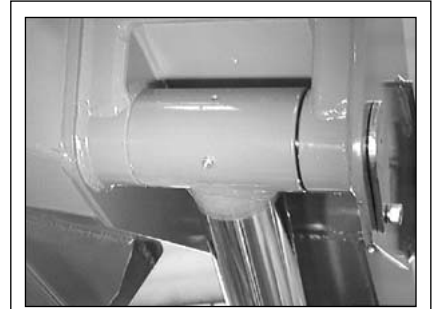

fig. 43c

fig. 43b

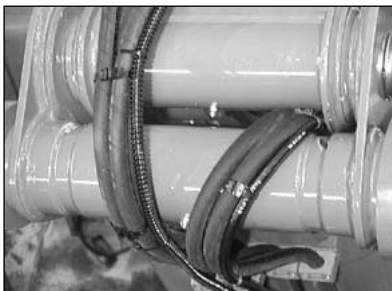
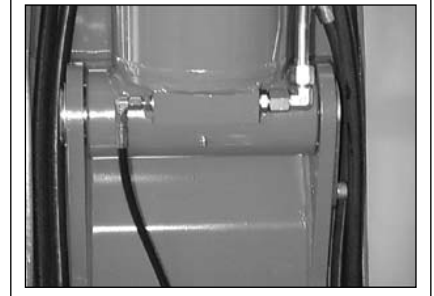

fig. 44

- Fig. 44-44a show the lubricators of the pin articulation column - inner boom and inner boom - outer boom.
 - Fig. 45-45a show the lubricator of the multifunction return deviator.
- Smear a light film of grease on the universal joints of the transmission rod.



fig. 44a

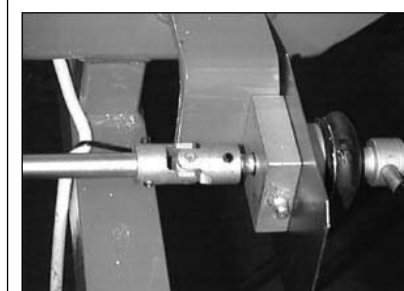

fig. 45



fig. 45a

When the hydraulic jib is fitted

- Fig. 46-46a show the lubricators of the articulation pins for connecting boom - jib outer boom and fork.

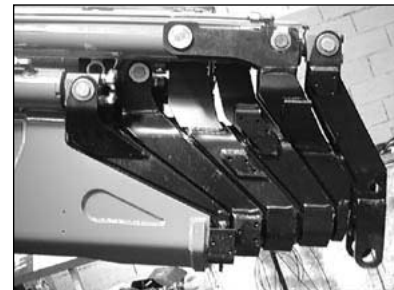
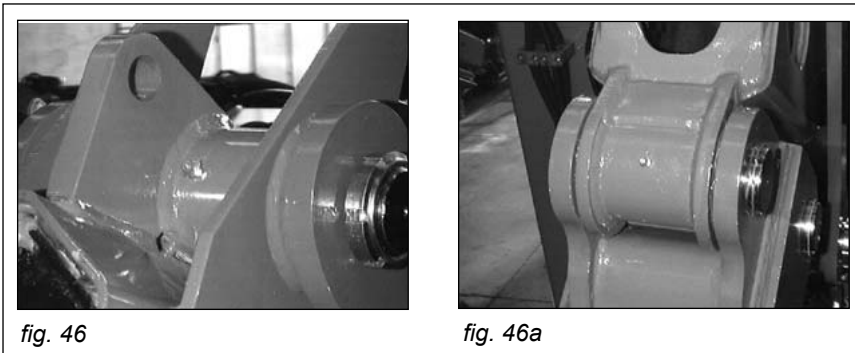

fig. 48

- Fig. 47-47a show the lubricators of the jib outer boom and of the fork.

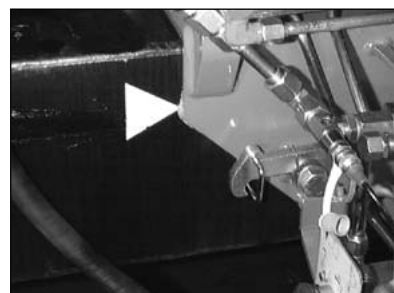
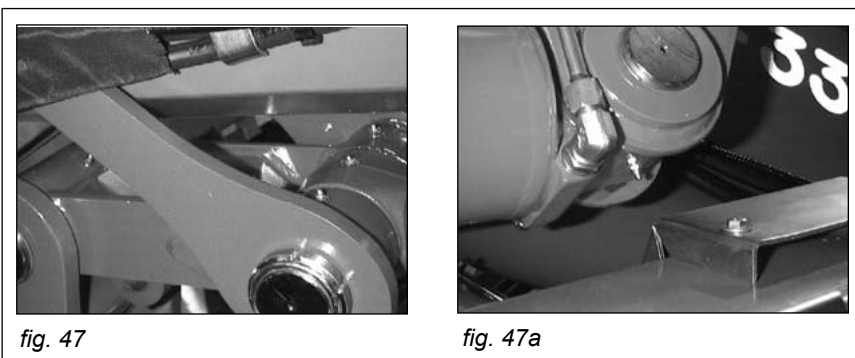

fig. 48a

For the sliding sections of the extension booms of the crane (fig. 48) and of the hydraulic jib (fig. 48b) and of the outrigger supports (fig. 48a) guide shoes made from a special material have been fitted: to ease their movement it is recommended to smear a light film of grease on them, taking care that the surfaces of the extension booms are free from impurities such as sand etc.



fig. 48b

Use a grease with the same characteristics indicated in the table on page 41.

After every 500 working hours

Check the tightening torque of the tie rods fixing the crane to the vehicle frame.

Check the tightening torque of the securing bolts for the ram pins.

Check the guide shoe wear as it affects the sliding section tolerances; if the clearances are considerable, damage to the rams and the structure may occur.

Replace the oil filter cartridges.

Clean the air filter placed in the top of the oil tank filter cap.

Completely replace the hydraulic oil.

(!) The waste oil must be disposed of by authorized persons.

POSSIBLE FAULTS

Many years experience of our product has allowed us to identify and classify the most common faults which occur. In most cases it requires accurate hydraulic and electric troubleshooting and simple rectification. In the following table we report the most frequent inconveniences and our suggested remedies.

(!) Checking and adjustment of oil pressures of valve settings must be carried out by an authorized service agent, otherwise warranty will be invalidate.

Operations which can be carried out by the user.

Faults	Cause	Remedies
The crane does not rotate properly	<i>Vehicle not in level position</i>	Stabilize the vehicle
	<i>Lack of lubrication</i>	Grease the bushes of the column and the guide shoe
The extension booms do not completely extend or work jerkily	<i>Lack of lubrication of the guide shoes</i>	Grease the guide shoes
Crane controls are not active	<i>Lack of electric energy</i>	Check the fuse, the battery and electric circuit
	<i>Winch end stroke active</i>	See Chapter XI
	<i>The rotation limiting device is activated</i>	See Chapter VIII
Vibrations in crane operations	<i>Shortage of oil</i>	Check the level and top up if necessary
	<i>Obstructed filters</i>	Clean or replace the filter cartridge
Noteable decrease in movement speed	<i>Obstructed filters</i>	Clean or replace the filter cartridge

Operations to be carried out by a service center.

Faults	Cause	Remedies
The crane does not lift the loads indicated on the capacity plate	<i>Non efficiency of the pump</i>	Replace the pump
	<i>Main pressure valve not properly adjusted, blocked or out of service</i>	Check the pressure, adjust the valve
	<i>Ram seals are not properly fitted</i>	Replace the seals
A boom of the crane does not hold up the load and visually lowers	<i>The safety check valve of the ram is open</i>	Replace the valve
	<i>Oil leaks inside the ram</i>	Defective seals, replace them
The crane does not rotate properly	<i>Valves controlling the rotation not adjusted</i>	Adjust the valves
	<i>Wear of the seals of the rotation cylinder</i>	Replace the seals
The extension booms do not completely extend or work jerkily	<i>Wear of guide shoes</i>	Check the guide shoes wear, replace if necessary
Vibrations in crane operations	<i>Non efficient pump</i>	Check the pump
Noteable decrease in movement speed	<i>Non efficient pump</i>	Check the pump

HYDRAULIC AND ELECTRIC SCHEMATICS

Hydraulic schematic for crane with HCD4 distributor - ground controls - lifting moment limiting device "intelligent type"

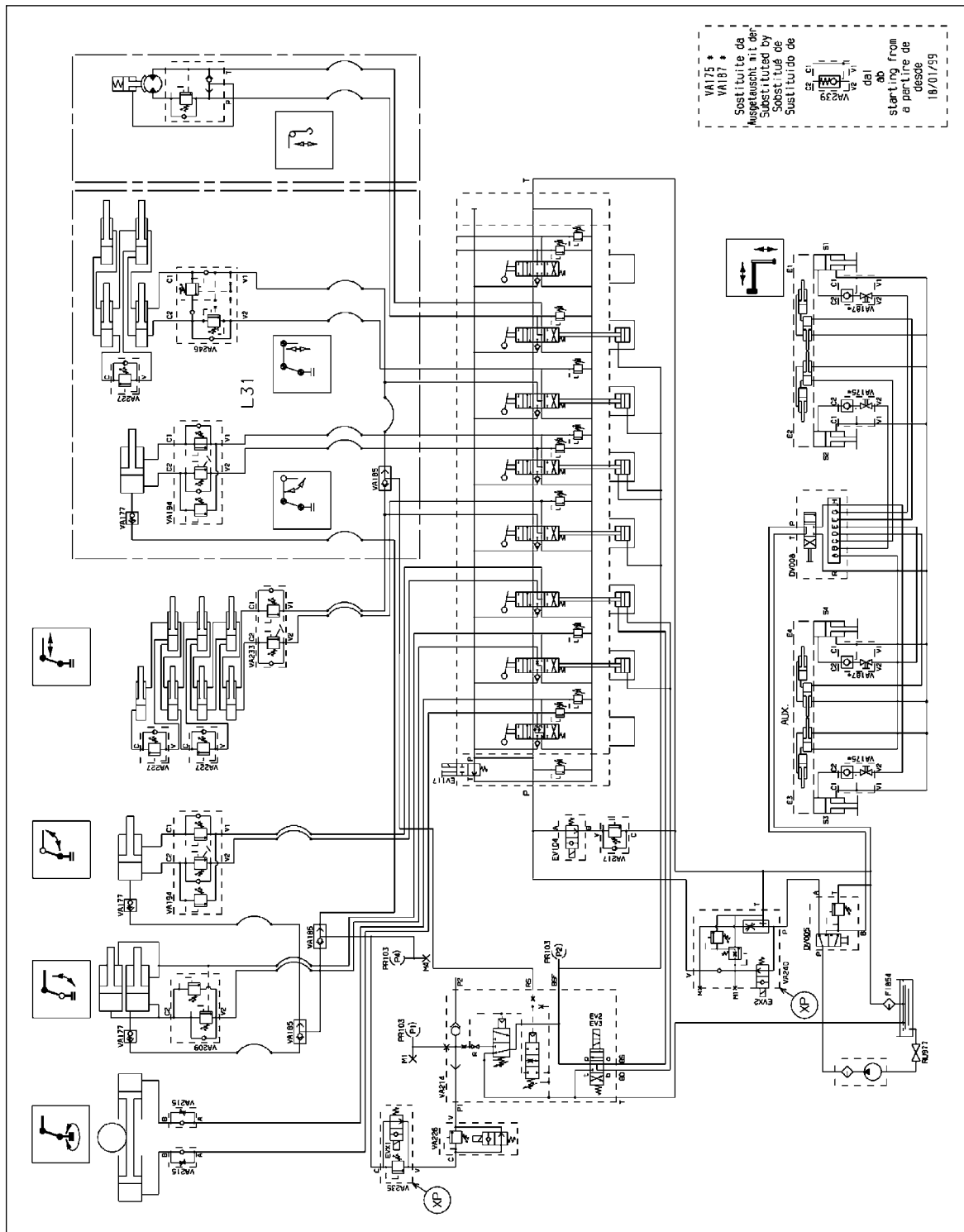

CODE	DESCRIPTION
DV005	DEVIATOR
DV008	DEVIATOR
EV104	ELECTROVALVE
EV117	ELECTROVALVE
FI870	FILTER
M1/M4	GAUGE QUICK CONNECTION
PR103	PRESSURE SWITCH
RU975	FAUCET
VA175	BLOCK VALVE + FAUCET
VA177	ANTIBURST VALVE FOR LIFTING RAMS
VA185	SELECTOR VALVE
VA187	BLOCK VALVE + FAUCET
VA194	DOUBLE EFFECT BLOCK VALVE

VA209	SIMPLE EFFECT BLOCK VALVE
VA215	OIL FLOW CHECK VALVE
VA217	SEQUENCE VALVE
VA224	LIFTING MOMENT LIMITING DEVICE VALVE
VA226	ELECTRIC MAIN WITH BY PASS VALVE
VA227	SEQUENCE VALVE
VA232	DOUBLE EFFECT BLOCK VALVE
VA239	SIMPLE EFFECT BLOCK VALVE
VA246	REGENERATIVE VALVE
XP	
VA235	ELECTRIC MAIN WITH BY PASS VALVE
VA240	"XP" VALVE

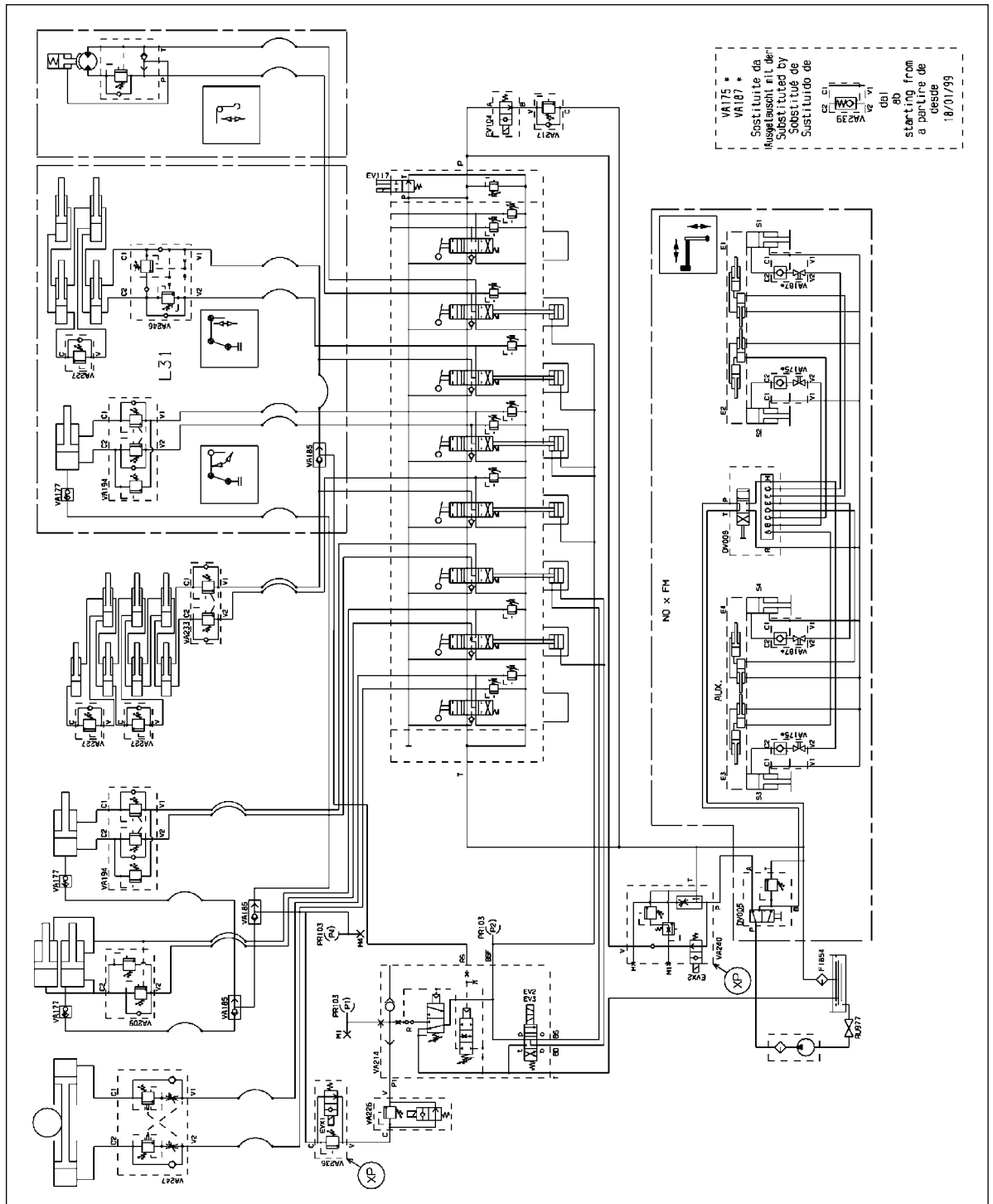

CODE	DESCRIPTION		
DV005	DEVIATOR	VA209	SIMPLE EFFECT BLOCK VALVE
DV008	DEVIATOR	VA214	LIFTING MOMENT LIMITING DEVICE VALVE
EV104	ELECTROVALVE	VA217	SEQUENCE VALVE
EV117	ELECTROVALVE	VA226	ELECTRIC MAIN WITH BY PASS VALVE
FI870	FILTER	VA227	SEQUENCE VALVE
M1/M4	GAUGE QUICK CONNECTION	VA232	DOUBLE EFFECT BLOCK VALVE
PR103	PRESSURE SWITCH	VA239	SIMPLE EFFECT BLOCK VALVE
RU975	FAUCET	VA246	REGENERATIVE VALVE
VA175	BLOCK VALVE + FAUCET	VA247	OIL FLOW REGULATOR VALVE FOR ROTATION CYLINDER
VA177	ANTIBURST VALVE FOR LIFTING RAMS		
VA185	SELECTOR VALVE	XP	
VA187	BLOCK VALVE + FAUCET	VA235	ELECTRIC MAIN WITH BY PASS VALVE
VA194	DOUBLE EFFECT BLOCK VALVE	VA240	"XP" VALVE

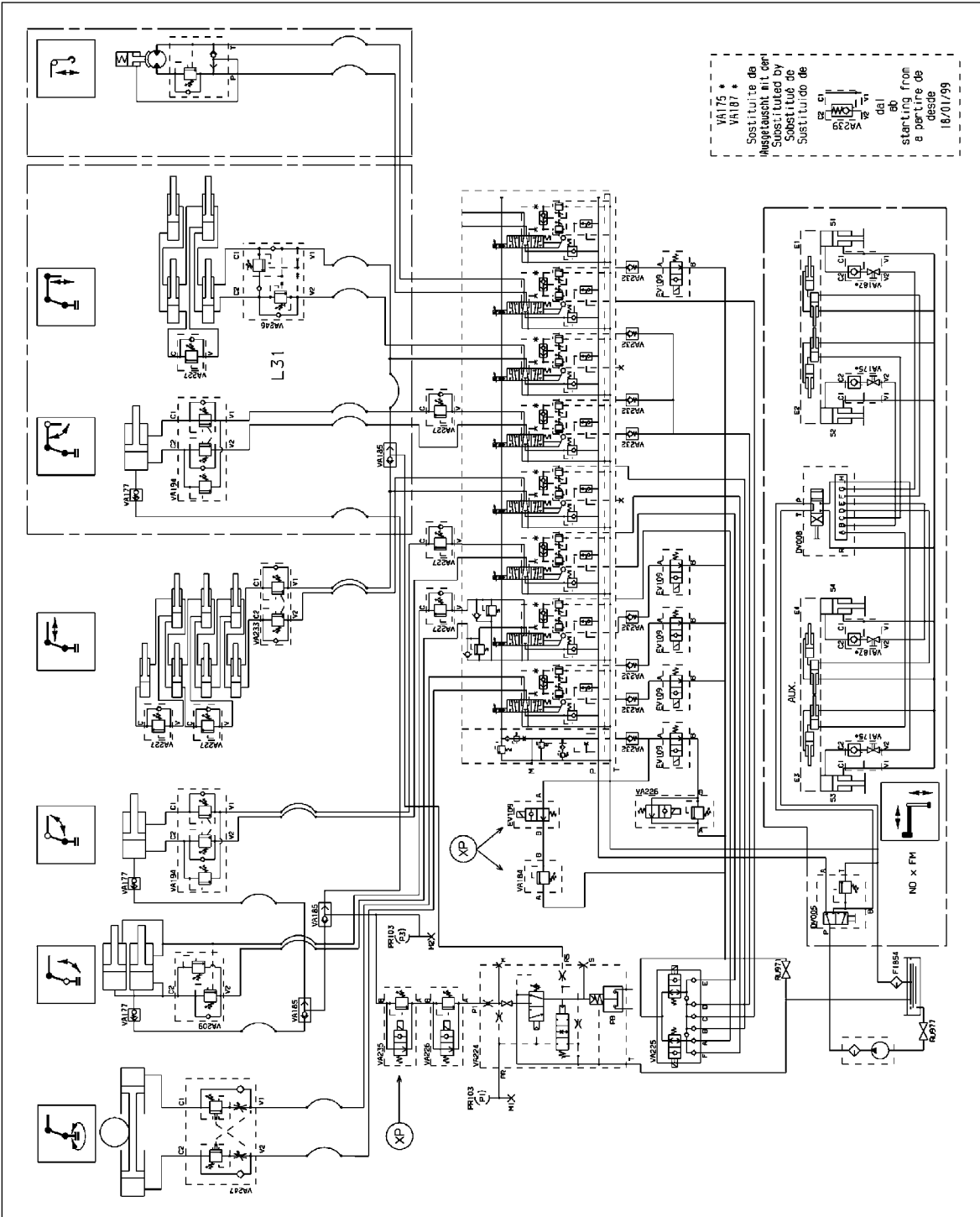

CODE DESCRIPTION

DV005	DEVIATOR
DV008	DEVIATOR
EV109	ELECTROVALVE
FI870	FILTER
M1/M4	GAUGE QUICK CONNECTION
PR103	PRESSURE SWITCH
RU971	FAUCET
RU975	FAUCET
VA102	DOUBLE EFFECT BLOCK VALVE
VA175	BLOCK VALVE + FAUCET
VA177	ANTIBURST VALVE FOR LIFTING RAMS
VA184	SENSOR VALVE
VA185	SELECTOR VALVE
VA187	BLOCK VALVE + FAUCET
VA194	DOUBLE EFFECT BLOCK VALVE

VA209	SIMPLE EFFECT BLOCK VALVE
VA224	LIFTING MOMENT LIMITING DEVICE VALVE
VA225	LEVEL SENSOR VALVE
VA226	ELECTRIC MAIN WITH BY PASS VALVE
VA227	SEQUENCE VALVE
VA232	UNIDIRECTIONAL VALVE
VA234	ELECTRIC MAIN WITH BY PASS VALVE
VA235	REGENERATIVE VALVE
VA239	SIMPLE EFFECT BLOCK VALVE
VA247	OIL FLOW REGULATOR VALVE FOR ROTATION CYLINDER
XP	
VA235	ELECTRIC MAIN WITH BY PASS VALVE
VA240	"XP" VALVE

FASSI

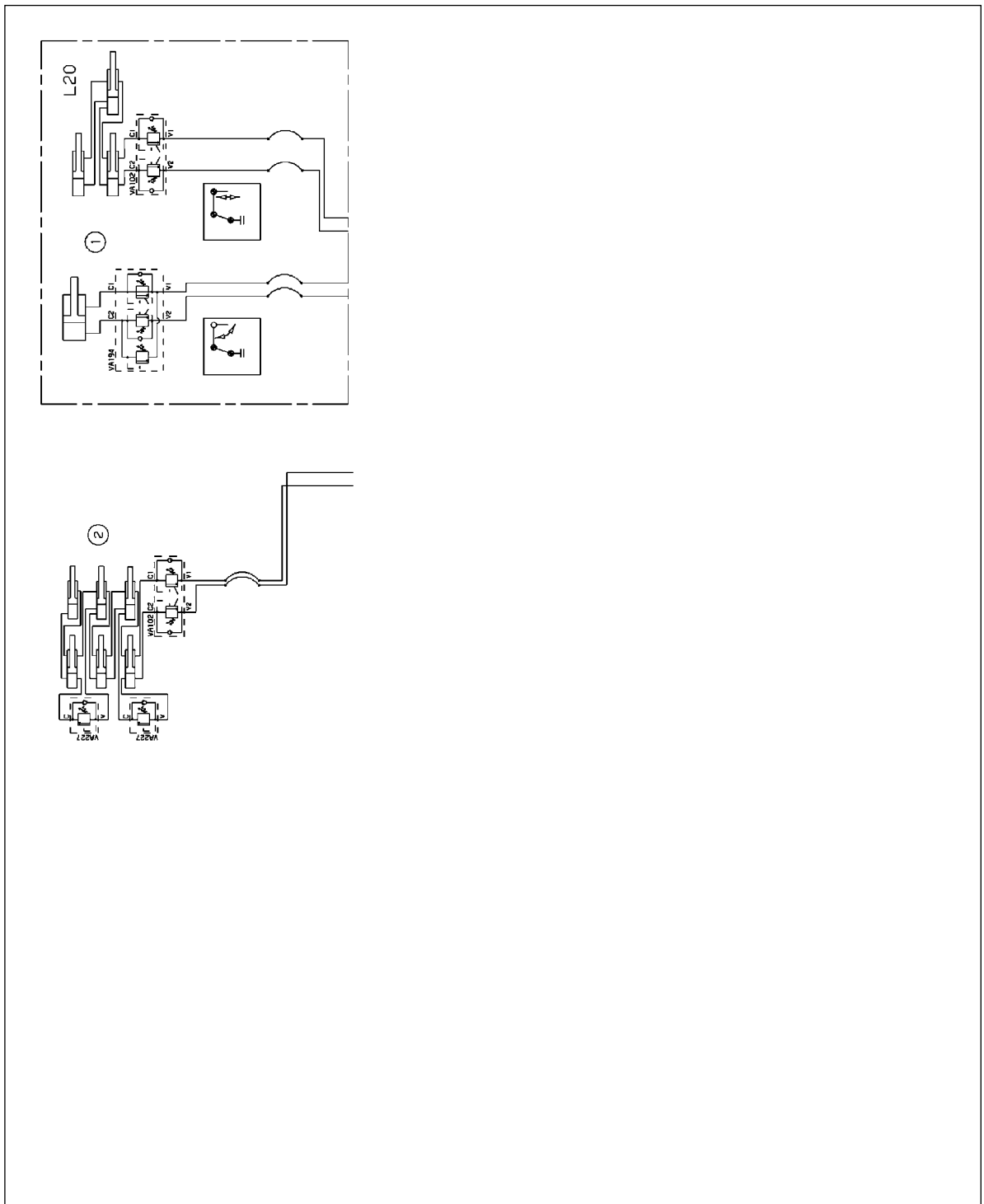

CODE	DESCRIPTION
VA102	DOUBLE EFFECT BLOCK VALVE
VA194	DOUBLE EFFECT BLOCK VALVE
VA227	SEQUENCE VALVE

Electric schematic for crane - arc of free rotation

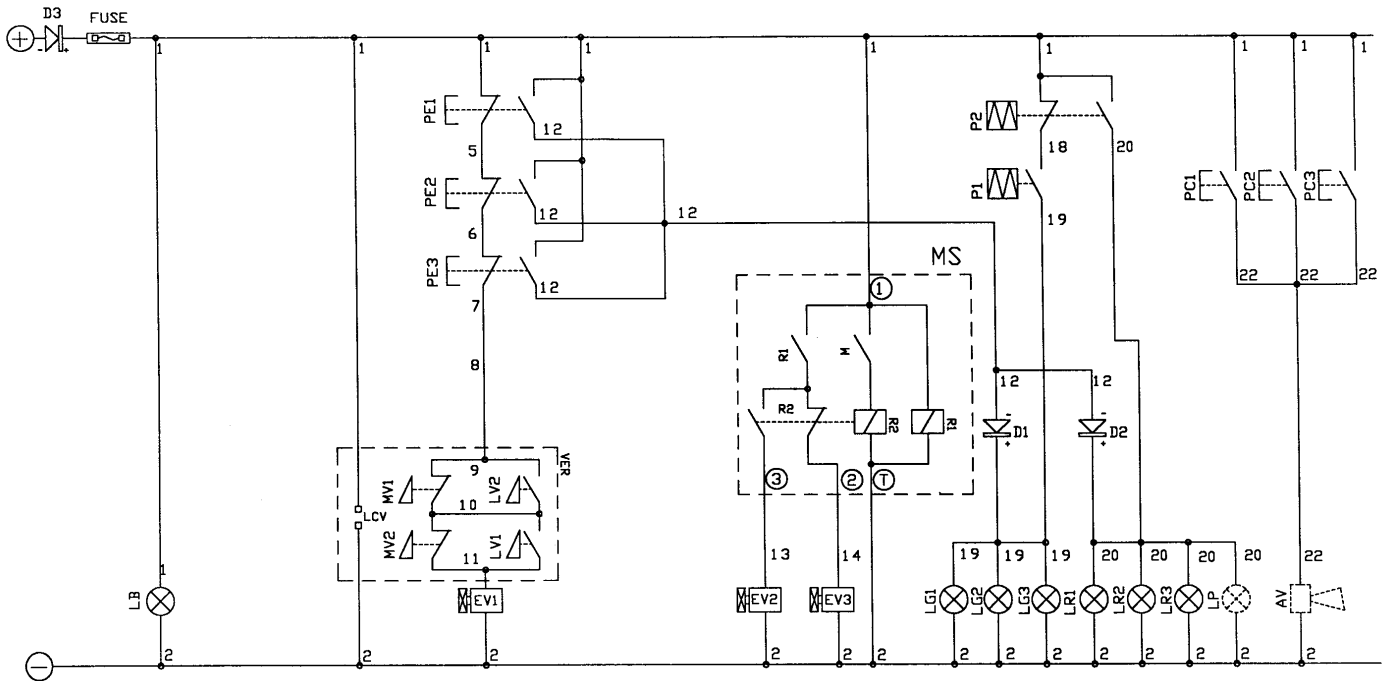

fig. 49

CODE	DESCRIPTION
ALIM	FEED MAIN CONTROL PANEL
AV	ACOUSTIC ALARM
LP	ADDITIONAL FLASHING
FUSE	PROTECTION FUSE 10 A.
D1-D2	LAMPS TEST DIODES
D3	POLARITY PROTECTION DIODE
EV1	EMERGENCY ELECTROVALVE
EV2	ELECTROVALVE FOR CRANE LIFTING BLOCK
EV3	ELECTROVALVE FOR CRANE DESCENTS BLOCK
MS	MERCURY SLOPE SENSOR ON OUTER BOOM
P1	LOAD PRESSURE 90% DETECTOR
P2	BLOCK PRESSURE DETECTOR
LB	WHITE WARNING LIGHT
LG1	YELLOW WARNING LIGHT FOR MAIN CONTROL PANEL 90% LOAD REACHING
LG2	YELLOW WARNING LIGHT FOR DOUBLE CONTROL SATELLITE 90% LOAD REACHING
LG3	YELLOW WARNING LIGHT FOR ADDITIONAL SATELLITE 90% LOAD REACHING
LR1	RED WARNING LIGHT FOR MAIN CONTROL PANEL BLOCK
LR2	RED WARNING LIGHT FOR DOUBLE CONTROL SATELLITE BLOCK
LR3	RED WARNING LIGHT FOR ADDITIONAL SATELLITE BLOCK
PE1	MAIN CONTROL PANEL STOP BUTTON
PE2	DOUBLE CONTROL SATELLITE STOP BUTTON
PE3	ADDITIONAL SATELLITE STOP BUTTON
PC1	ACOUSTIC WARNING BUTTON FOR MAIN CONTROL PANEL
PC2	ACOUSTIC WARNING BUTTON FOR DOUBLE CONTROL SATELLITE
PC3	ACOUSTIC WARNING BUTTON FOR ADDITIONAL SATELLITE
SAT2	DOUBLE CONTROL SIDE SATELLITE
SAT3	ADDITIONAL SATELLITE
AR1	CRANE WINDING
AR2	EXTENSION WINDING
LCV	WINCH LOAD LIMITING DEVICE
MV1	PULLEY MICRO WINCH
MV2	DRUM MICRO WINCH
LV1	MICRO LEVER FOR CABLE WINDING REACTIVATION
LV2	MICRO LEVER FOR CABLE UNWINDING REACTIVATION

Electric schematic for crane - limited arc rotation

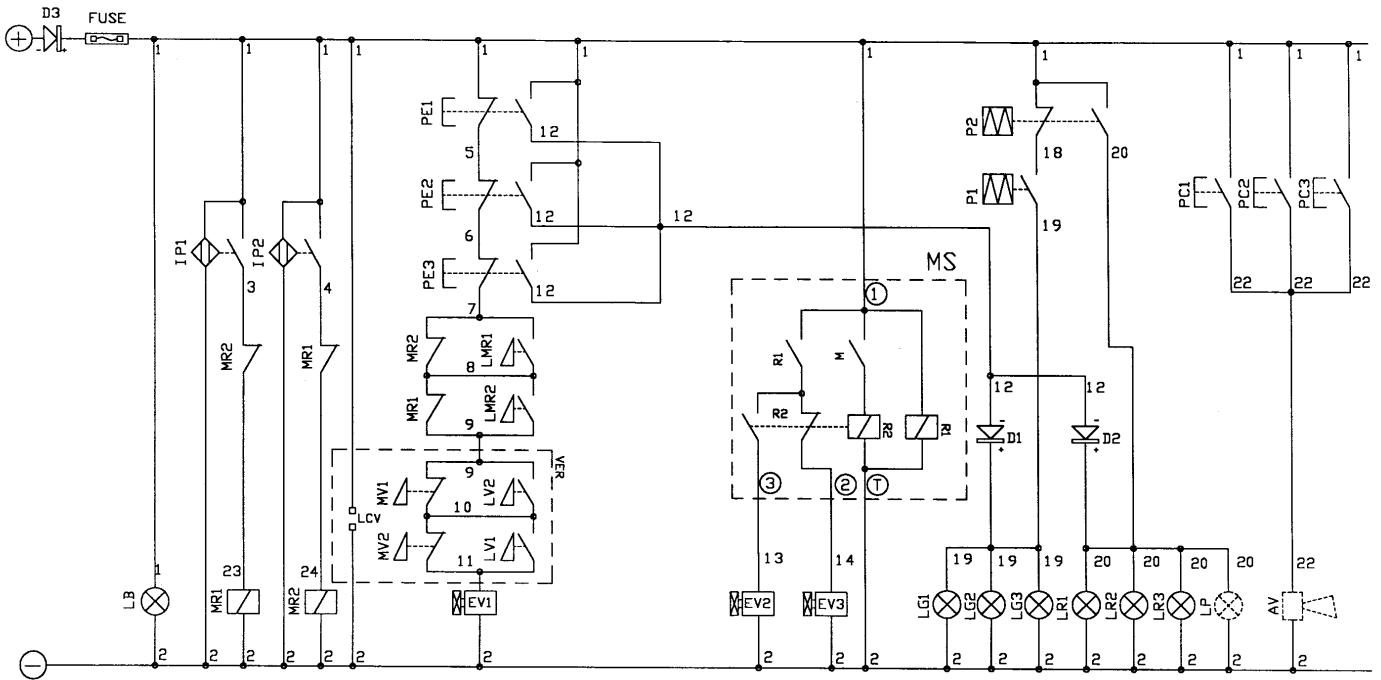

fig. 50

CODE	DESCRIPTION
ALIM	FEED MAIN CONTROL PANEL
AV	ACOUSTIC ALARM
LP	ADDITIONAL FLASHING
FUSE	PROTECTION FUSE 10 A.
D1-D2	LAMPS TEST DIODES
D3	POLARITY PROTECTION DIODE
EV1	EMERGENCY ELECTROVALVE
EV2	ELECTROVALVE FOR CRANE LIFTING BLOCK
EV3	ELECTROVALVE FOR CRANE DESCENTS BLOCK
IP1	CLOCKWISE ROTATION PROXIMITY
IP2	ANTICLOCKWISE ROTATION PROXIMITY
SDP	SEAT PROXIMITY SHUNT BOX
MR1	CLOCKWISE ROTATION RELAY
MR2	ANTICLOCKWISE ROTATION RELAY
LMR1	CLOCKWISE ROTATION MICRO REACTIVATION
LMR2	ANTICLOCKWISE ROTATION MICRO REACTIVATION
MS	MERCURY SLOPE SENSOR ON OUTER BOOM
P1	LOAD PRESSURE 90% DETECTOR
P2	BLOCK PRESSURE DETECTOR
LB	WHITE WARNING LIGHT
LG1	YELLOW WARNING LIGHT FOR MAIN CONTROL PANEL 90% LOAD REACHING
LG2	YELLOW WARNING LIGHT FOR DOUBLE CONTROL SATELLITE 90% LOAD REACHING
LG3	YELLOW WARNING LIGHT FOR ADDITIONAL SATELLITE 90% LOAD REACHING
LR1	RED WARNING LIGHT FOR MAIN CONTROL PANEL BLOCK
LR2	RED WARNING LIGHT FOR DOUBLE CONTROL SATELLITE BLOCK
LR3	RED WARNING LIGHT FOR ADDITIONAL SATELLITE BLOCK
PE1	MAIN CONTROL PANEL STOP BUTTON
PE2	DOUBLE CONTROL SATELLITE STOP BUTTON
PE3	ADDITIONAL SATELLITE STOP BUTTON
PC1	ACOUSTIC WARNING BUTTON FOR MAIN CONTROL PANEL
PC2	ACOUSTIC WARNING BUTTON FOR DOUBLE CONTROL SATELLITE
PC3	ACOUSTIC WARNING BUTTON FOR ADDITIONAL SATELLITE
SAT2	DOUBLE CONTROL SIDE SATELLITE
SAT3	ADDITIONAL SATELLITE
AR1	CRANE WINDING
AR2	EXTENSION WINDING
LCV	WINCH LOAD LIMITING DEVICE
MV1	PULLEY MICRO WINCH
MV2	DRUM MICRO WINCH
LV1	MICRO LEVER FOR CABLE WINDING REACTIVATION
LV2	MICRO LEVER FOR CABLE UNWINDING REACTIVATION

Electric schematic for crane - diversified arc rotation

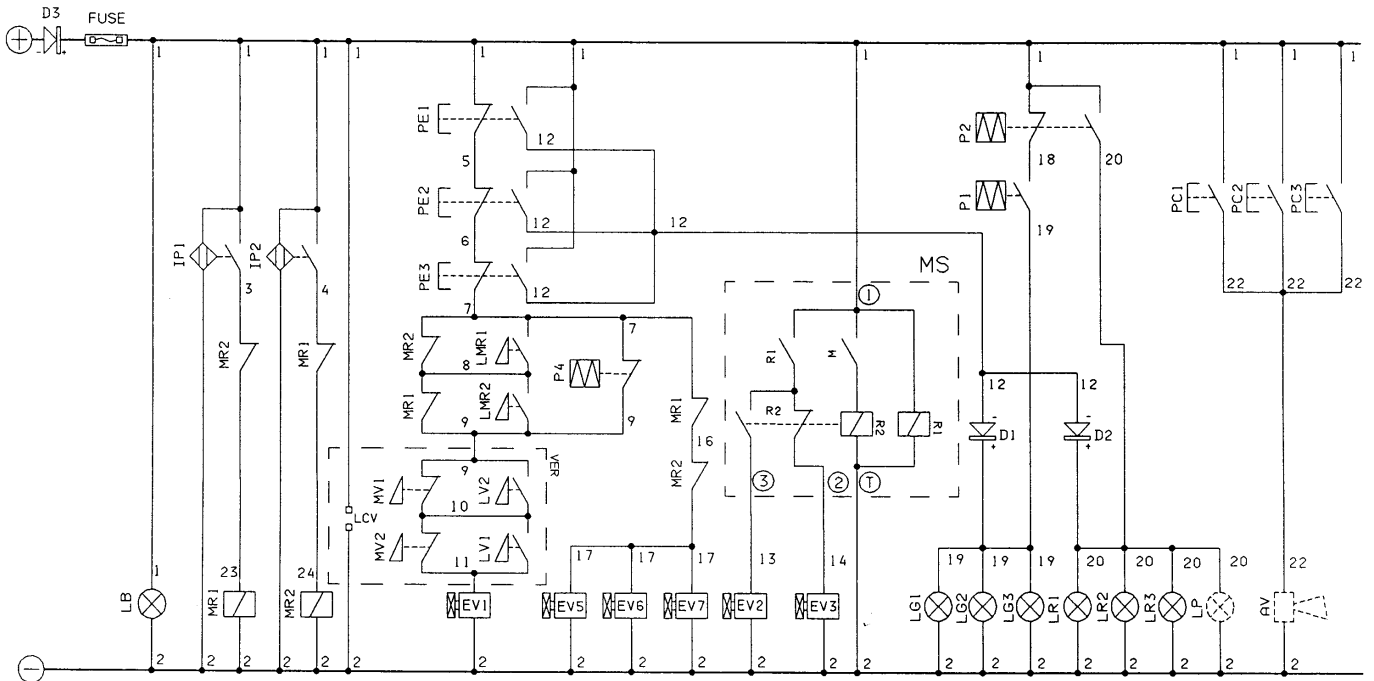

fig. 51

CODE	DESCRIPTION
ALIM	FEED MAIN CONTROL PANEL
AV	ACOUSTIC ALARM
IP	ADDITIONAL FLASHING
FUSE	PROTECTION FUSE 10 A
D1-D2	LAMPS TEST DIODES
D3	POLARITY PROTECTION DIODE
EV1	EMERGENCY ELECTROVALVE
EV2	ELECTROVALVE FOR CRANE LIFTING BLOCK
EV3	ELECTROVALVE FOR CRANE DESCENTS BLOCK
EV6	ELECTROVALVE FOR CRANE LIFTING MOMENT LIMITING DEVICE OF THE TWO WORKING ZONES
EV7	ELECTROVALVE FOR LIMITING GENERAL PRESSION
IP1	CLOCKWISE ROTATION PROXIMITY
IP2	ANTICLOCKWISE ROTATION PROXIMITY
SDP	SEAT PROXIMITY SHUNT BOX
MR1	CLOCKWISE ROTATION RELAY
MR2	ANTICLOCKWISE ROTATION RELAY
LMR1	CLOCKWISE ROTATION MICRO REACTIVATION
LMR2	ANTICLOCKWISE ROTATION MICRO REACTIVATION
MS	MERCURY SLOPE SENSOR ON OUTER BOOM
P1	LOAD PRESSURE 90% DETECTOR
P2	BLOCK PRESSURE DETECTOR
P4	ROTATION CONTROL PRESSURE DETECTOR
LB	WHITE WARNING LIGHT
LG1	YELLOW WARNING LIGHT FOR MAIN CONTROL PANEL 90% LOAD REACHING
LG2	YELLOW WARNING LIGHT FOR DOUBLE CONTROL SATELLITE 90% LOAD REACHING
LG3	YELLOW WARNING LIGHT FOR ADDITIONAL SATELLITE 90% LOAD REACHING
LR1	RED WARNING LIGHT FOR MAIN CONTROL PANEL BLOCK
LR2	RED WARNING LIGHT FOR DOUBLE CONTROL SATELLITE BLOCK
LR3	RED WARNING LIGHT FOR ADDITIONAL SATELLITE BLOCK
PE1	MAIN CONTROL PANEL STOP BUTTON
PE2	DOUBLE CONTROL SATELLITE STOP BUTTON
PE3	ADDITIONAL SATELLITE STOP BUTTON
PC1	ACOUSTIC WARNING BUTTON FOR MAIN CONTROL PANEL
PC2	ACOUSTIC WARNING BUTTON FOR DOUBLE CONTROL SATELLITE
PC3	ACOUSTIC WARNING BUTTON FOR ADDITIONAL SATELLITE
SAT2	DOUBLE CONTROL SIDE SATELLITE
SAT3	ADDITIONAL SATELLITE
AR1	CRANE WINDING
AR2	EXTENSION WINDING
LCV	WINCH LOAD LIMITING DEVICE
MV1	PULLEY MICRO WINCH
MV2	DRUM MICRO WINCH
LV1	MICRO LEVER FOR CABLE WINDING REACTIVATION
LV2	MICRO LEVER FOR CABLE UNWINDING REACTIVATION

CONTROL PANELS

control panel cover

fig. 52

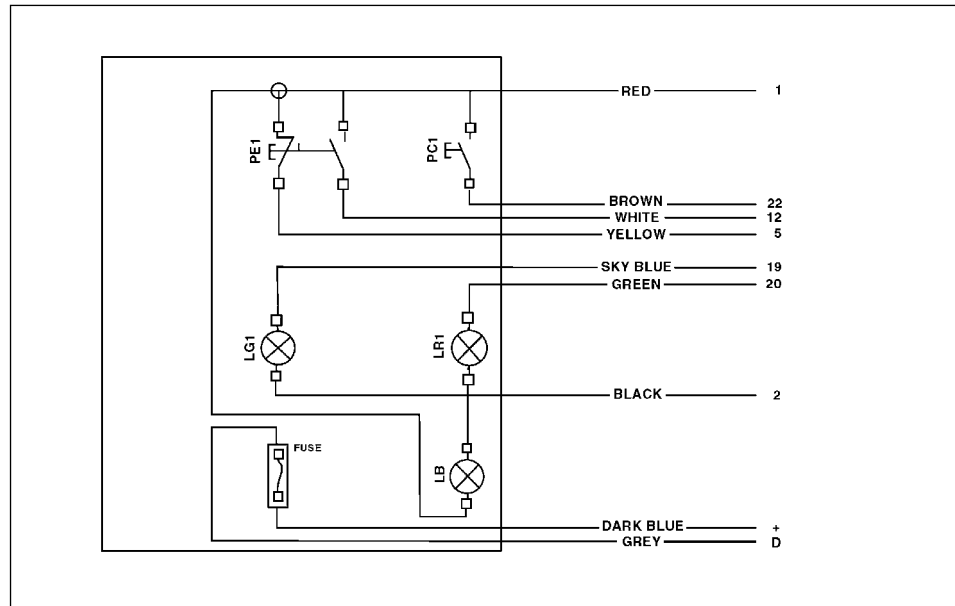

top seat satellite

fig. 53

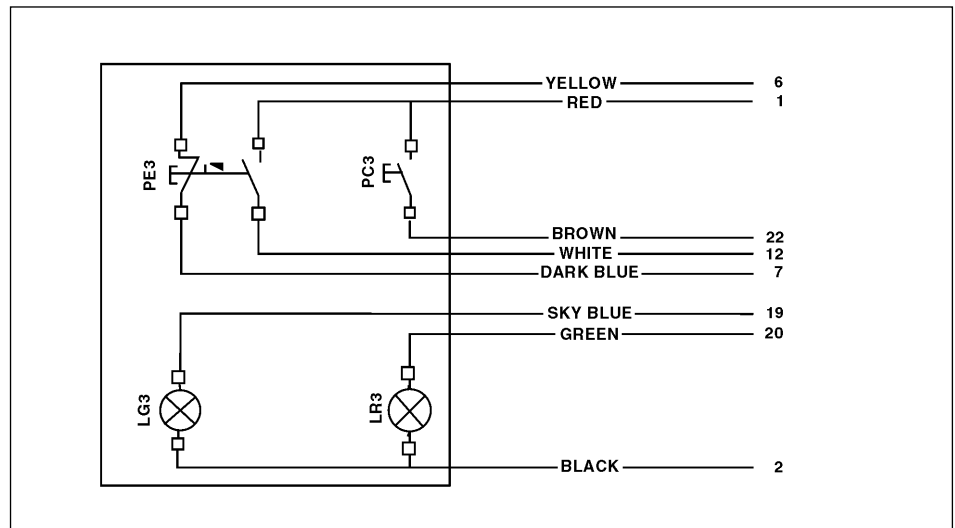

double control satellite

fig. 54

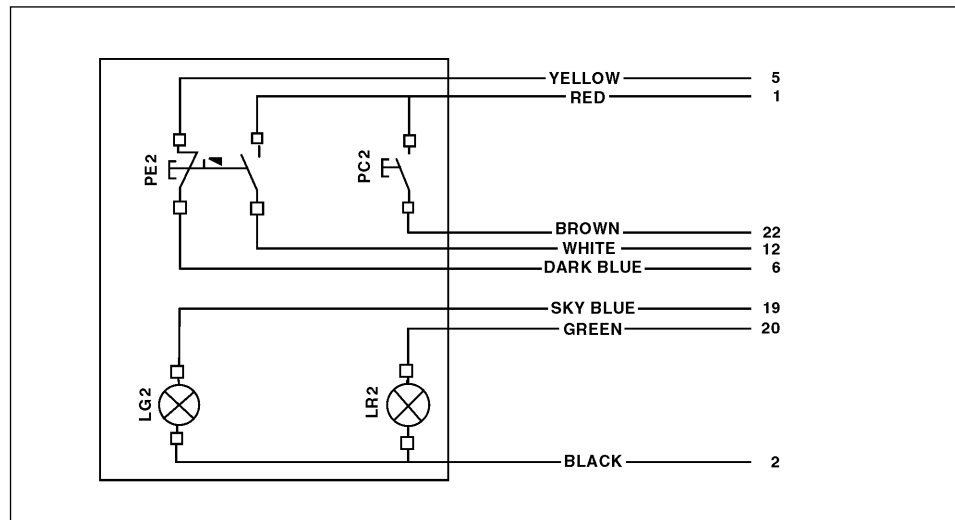

HYDRAULIC OIL WITH HIGH VISCOSITY: ISO-L-HV

Minimal external temperature :	maximal oil temperature:		
- 35 C	+45 C	Gradation	ISO VG 32
- 20 C	+75 C	Gradation	ISO VG 46

HYDRAULIC OIL WEAR RESISTANT: ISO-L-HM

Minimal external temperature :	maximal oil temperature:		
-10 C	+ 60 C	Gradation	ISO VG 32
+ 0 C	+ 75 C	Gradation	ISO VG 46
+ 5 C	+ 85 C	Gradation	ISO VG 68
+10 C	+ 90 C	Gradation	ISO VG 100

GREASE

Consistency: NLGI BEACON EP 2 - BEACON 3

(!) WARNING (!)

Don't use greases with solid particles as "Bisulphide of Molybdenum".

LUBRICATING OIL (for winch cable)

The most suitable here is a general-purpose lubricating oil with about SAE 30 viscosity. A lubricating oil containing non-stick additives is recommended if the cables are expected to move quickly through the pulleys.

BRILUBE 50 (BRITISH ROPES - BRINDON)

	<p>FASSI GRU IDRAULICHE SpA 24021 ALBINO (BG) ITALY - Via dei Carmelitani, 2 Tel. + 39 35 77.64.00 - Fax + 39 35 75.50.20</p>	<h2>INSTRUCTIONS FOR SAFE USE OF THE CRANE</h2>	DE1771
<ol style="list-style-type: none"> 1 Only authorized persons are permitted to operate the crane. 2 The crane must be used on firm, level ground. 3 Check that the vehicle hand brake is on and that the wheels are chocked. 4 Before operation make sure that: <ul style="list-style-type: none"> - no-one is within the working area of the crane; - the safety devices are in place and operative; - the minimum safe working distances from power lines are observed; - the load is correctly slung and hooked. 5 Stabilize the vehicle with the outriggers, making sure that: <ul style="list-style-type: none"> - the lateral supports are fully extended; - the wheels are in contact with the ground and the suspension is not completely unloaded; - the outriggers safety taps are closed. 6 Use the crane in accordance with the use and maintenance manual, making sure that: <ul style="list-style-type: none"> - the load and radius are within the maximum limits shown on the crane capacity plate; - the crane is used progressively avoiding sudden load movements; - swinging or dragging of the load is avoided; - the load is lifted before rotating. 7 When using implements protect the working area with a barrier. 8 The vehicle/crane are not left unless the power take off is disengaged and the load is on the ground. 9 Before driving the vehicle ensure that the outriggers are fully retracted and re-entered, the safety taps closed and the crane is in the folded position. 			

DE 1771 Instruction plate and safety norms

FASSI
GRU IDRAULICHE

- **ATTENZIONE:** PRIMA DI AZIONARE LA GRU E' OBBLIGATORIO METTERE IN OPERA GLI STABILIZZATORI E CHIUDERE I RUBINETTI DELLE VALVOLE DI BLOCCO.

- **WARNING:** BEFORE OPERATING THE CRANE IT IS COMPULSORY TO EXTEND THE OUTRIGGERS AND SHUT THE BLOCK VALVETAPS.

- **ATTENTION:** AVANT D'UTILISER LA GRUE IL EST OBLIGATOIRE DE METTRE EN FONCTION LES STABILISATEURS ET FERMER LES ROBINETS DES VALVES DE BLOCCAGE.

- **ACHTUNG:** VOR INBETRIEBNAHME DES KRANS MUESSEN DIE ABSTUETZUNGEN AUSGEFAHREN UND DIE ABSPERRVENTILE GESCHLOSSEN WERDEN.

DE319

DE 319

Warning plate to stabilize the vehicle before using the crane

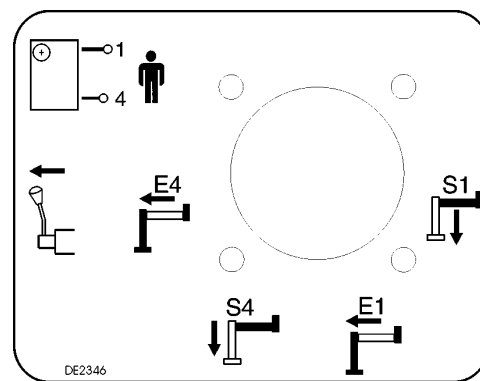
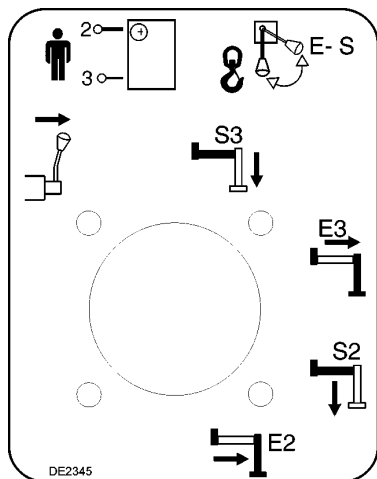

Instruction plates
to stabilize the vehicle

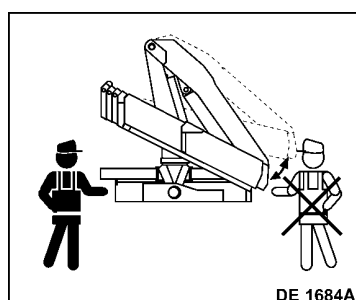

DE 1684A

Do not operate from the double control side to unfold or fold the crane



DE 1681
Greasing points with brush



DE 1682
Greasing points at pressure

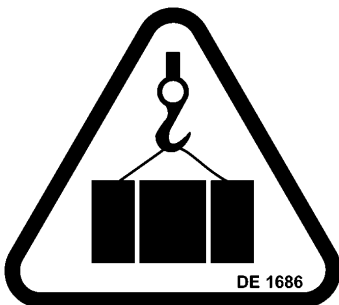

DE 1686
Do not walk or stop under a suspended load

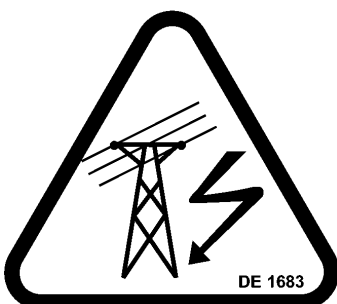

DE 1683
Do not operate in proximity of electric high-tension lines

**DE 1679**

Do not walk on...

**DE 1680**

Do not use water to extinguish fire

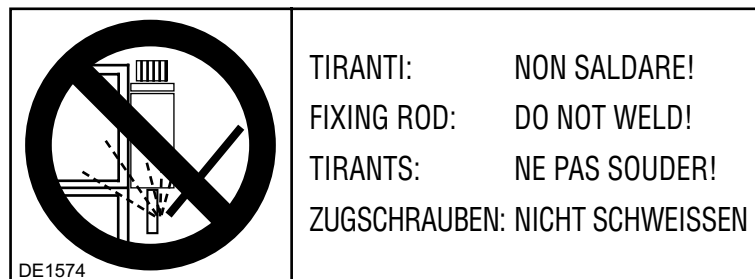
**DE 1574**

Do not weld the fixing rods

CAPACITY PLATES

For cranes and manual extensions.

The represented plates refer to the nominal design capacities.

! WARNING !

If the capacities are downgraded or partially reduced (e.g. sector in front of vehicle cab) capacity plates must be applied in line with the final test figures.

