

## Specifications

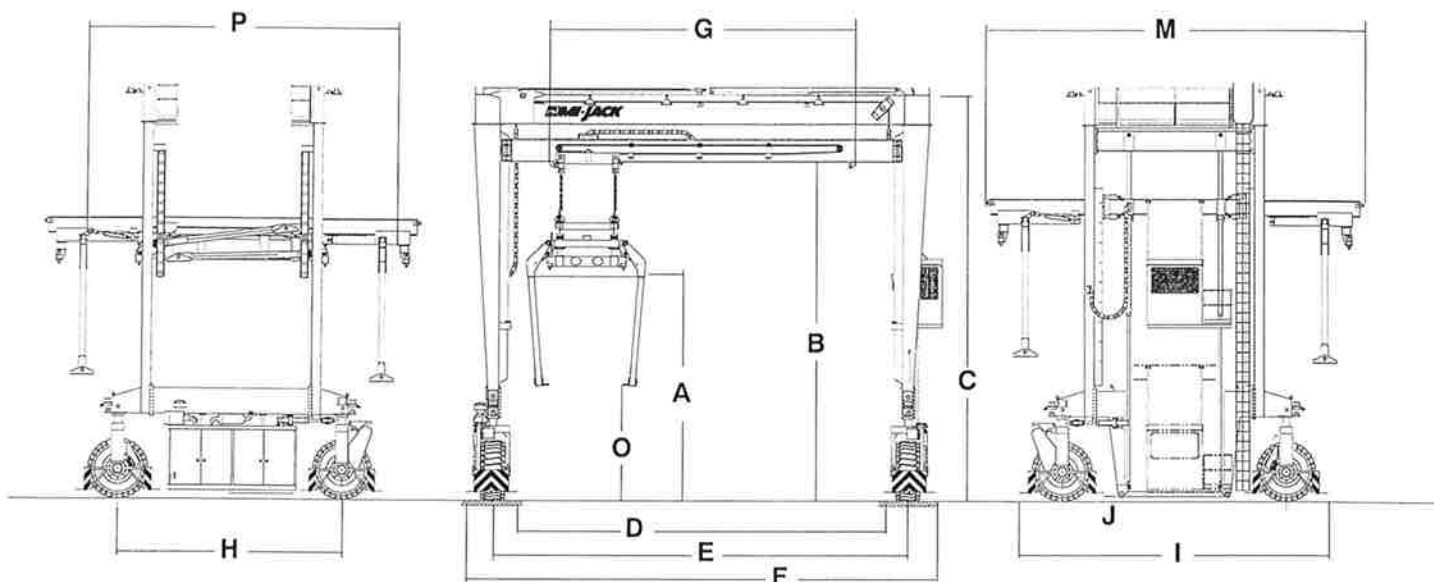

**DIMENSION DATA**

DIMENSION DATA			
A. Height to Twistlocks	23'10"	23'10"	23'10"
B. Height to Bottom of Stabilizing Beam (max.)	31'10"	31'10"	31'10"
C. Overall Height of Machine	39'11"	39'11"	42'9"
D. Inside Clear Width*	38'10"	43'6"	50'3"
E. Wheel Tread C/L to C/L	42'6"	50'	55'
F. Overall Width	48'1"	54'6"	59'6"
G. Lateral Travel of Trolley	23'10"	29'6"	34'6"
H. Wheel Base	23'0"	23'0"	23'0"
I. Length to Outside of Wheel Guards	29'10"	29'10"	29'10"
J. Cab to Ground	20"	20"	20"
M. Overall Length of Grappler "B" Series	41'5"	41'5"	41'5"
O. Maximum Height of Grappler Shoes	12'2"	12'2"	12'2"
P. Grappler Arm Adjustment Range	(min.)	14'3"	14'3"
	(max.)	34'3"	34'3"

Tire Deflection is not included in these measurements.

\*Other Machine sizes are available. Please call the factory for more information.

### OPTIONAL SPECIFICATIONS & EQUIPMENT

- 20' - 40' universal grappler
- Detroit Diesel Series 50 engine; 300 hp @ 2200RPM
- Special sound package
- Soft touch/Side shift
- Wheel guards with automatic shutdown
- Air conditioner
- 300 gallon fuel tank
- Camera system
- Auto guidance
- Scale system
- Tool box
- Hi-speed hoist package
- Elevating hydraulic cab, 6'4" to 21'
- Automatic spreader extent/retract
- Automatic side shift restore

3111 W. 167th Street, Hazel Crest, IL 60429 • (708) 596-5200 • Fax (708) 225-2312



## Specifications

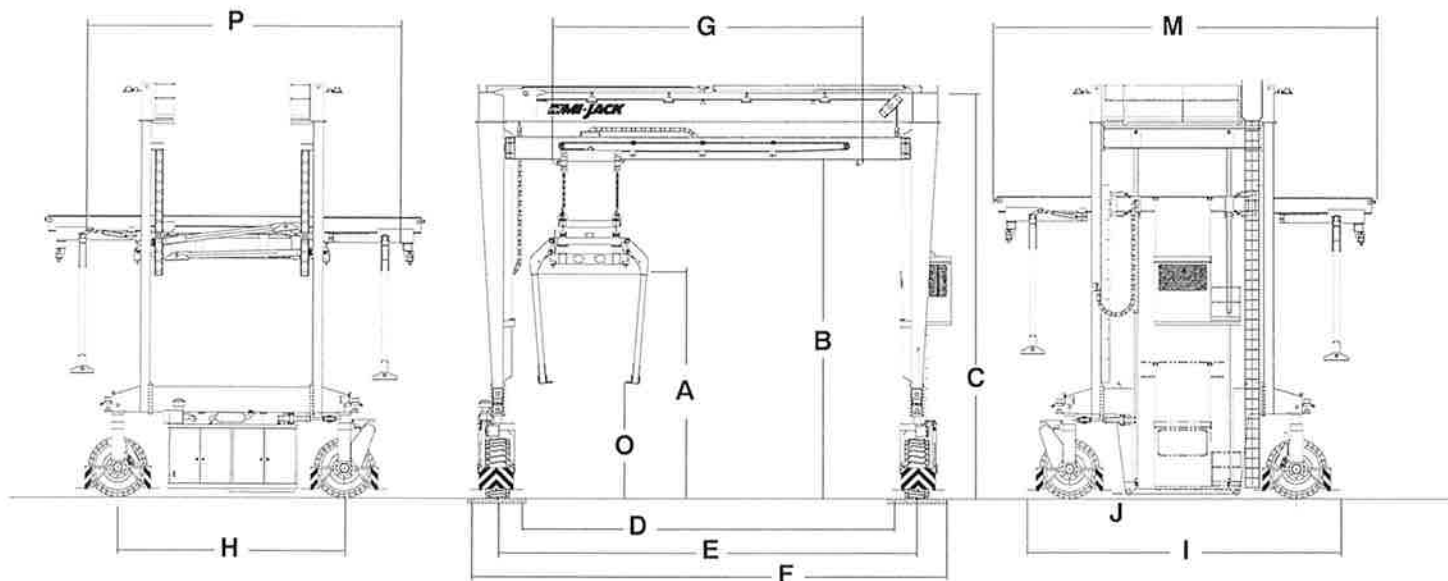

**DIMENSION DATA**

A. Height to Twistlocks	23'10"	23'10"	23'10"
B. Height to Bottom of Stabilizing Beam (max.)	31'10"	31'10"	31'10"
C. Overall Height of Machine	39'11"	39'11"	42'9"
D. Inside Clear Width*	38'10"	43'6"	50'3"
E. Wheel Tread C/L to C/L	42'6"	50'	55'
F. Overall Width	48'1"	54'6"	59'6"
G. Lateral Travel of Trolley	23'10"	29'6"	34'6"
H. Wheel Base	23'0"	23'0"	23'0"
I. Length to Outside of Wheel Guards	29'10"	29'10"	29'10"
J. Cab to Ground	20"	20"	20"
M. Overall Length of Grappler "B" Series	41'5"	41'5"	41'5"
O. Maximum Height of Grappler Shoes	12'2"	12'2"	12'2"
P. Grappler Arm Adjustment Range	(min.)	14'3"	14'3"
	(max.)	34'3"	34'3"

Tire Deflection is not included in these measurements.

\*Other Machine sizes are available. Please call the factory for more information.

### OPTIONAL SPECIFICATIONS & EQUIPMENT

- 20' - 40' universal grapple
- Detroit Diesel Series 50 engine; 300 hp @ 2200RPM
- Special sound package
- Soft touch/Side shift
- Wheel guards with automatic shutdown
- Air conditioner
- 300 gallon fuel tank
- Camera system
- Auto guidance
- Scale system
- Tool box
- Hi-speed hoist package
- Elevating hydraulic cab, 6'4" to 21'
- Automatic spreader extent/retract
- Automatic side shift restore

3111 W. 167th Street, Hazel Crest, IL 60429 • (708) 596-5200 • Fax (708) 225-2312

