

FASSI
GRU IDRAULICHE
F330.23
❖ = Mmax 232491 lbs.ft
⚙ = Pmax 27558 lbs

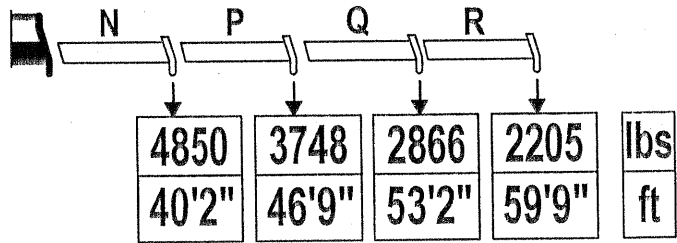
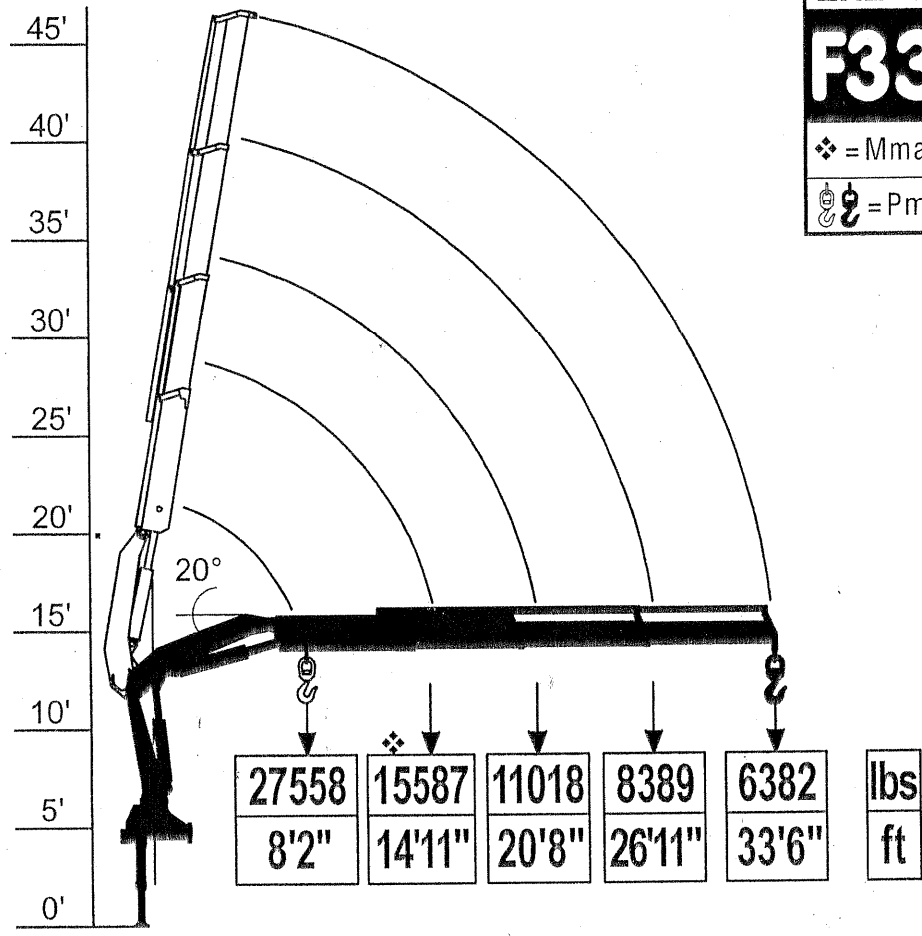

lbs N (275) P (185) Q (163) R (123)

DE 1963

F330.23

use and maintenance

Edition CE 95.06.26

INDEX

Chapter	I	INTRODUCTION	Page	2
	II	SAFETY NORMS	Page	3
	III	INSTRUCTIONS FOR CRANE USE	Page	6
	IV	IDENTIFICATION OF THE CRANE MODEL	Page	7
	V	TECHNICAL DATA	Page	8
	VI	CRANE NOMENCLATURE	Page	10
	VII	SAFETY AND PROTECTION DEVICES	Page	12
	VIII	LIFTING MOMENT LIMITING DEVICE AND CONTROL PANELS	Page	14
	IX	ROTATION LIMITING DEVICE	Page	18
	X	CONTROLS TO STABILIZE THE VEHICLE	Page	19
	XI	CONTROLS TO OPERATE THE CRANE	Page	23
	XII	USE OF IMPLEMENTS	Page	26
	XIII	MAINTENANCE INSTRUCTIONS	Page	29
	XIV	POSSIBLE FAULTS	Page	32
	XV	HYDRAULIC AND ELECTRIC SCHEMATICS	Page	33
	XVI	OIL AND LUBRICANT CHARACTERISTICS	Page	39
	A	INSTRUCTION AND WARNING PLATES	Page	40
	B	CAPACITY PLATES	Page	43

FASSI CRANE

F330.23

use and maintenance

INTRODUCTION

This instruction manual describes the FASSI CRANE F330.23.

The crane, which conforms to the Machines Directive 89/392, 91/368 and 93/44 must not be put into service within the European Community unless the machine on which it is mounted also conforms with the prescribed Directive.

The fitment must be carried out at an authorized Fassi Centre in accordance with the instructions given by the Manufacturer in the manual for hydraulic crane fitting.

The Manufacturer declines all responsibility and guarantee if the fitting is entrusted to workshops without sufficient technical capability to carry out the work in conformity.

Every change of use, modification or addition of accessories, away from the original crane specification must be affixed with a new CE mark in accordance with the Machinery Directive.

As well as the principal safety norms, this manual contains a description of the crane and the instructions for use and maintenance.

Equipment other than Fassi must be supplied with its own use manual.

The crane must only be operated by responsible persons, previously instructed and authorized.

THANK YOU FOR SELECTING ONE OF OUR CRANES.

(!) This symbol draws your attention on the points concerning safety.
It means: **WARNING! BE CAREFUL!**
IT CONCERNS YOUR SAFETY!

!ATTENTION!

READ THIS MANUAL CAREFULLY prior to use of the crane or any maintenance.

A few minutes spent now could save time and labour later.

Be sure that the unit has been installed, inspected and tested in accordance with the local legal requirements.

To operate the crane it is necessary to fully understand its working, safety and warranty norms.

Warning plates, as well as instruction and operation plates must be replaced when no longer readable or missing.

Check that protections are in their place and that all safety devices are fitted and active.

Do not run the engine in a indoor area without first making sure there is adequate ventilation.

Stabilize the vehicle by means of the outrigger rams, checking that they rest on a solid base; if in doubt use special larger outrigger base plates (available on request).

Level the crane so as it is always operated on a horizontal plane.

Check that the taps of the outrigger rams safety check valves are closed. Never operate the outriggers when the crane is loaded.

Remember that the stability of the unit (crane-vehicle) is only guaranteed by the maximum lateral extension of the outriggers.

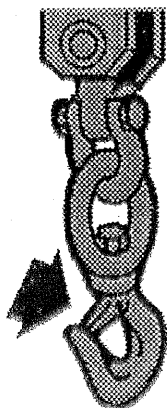
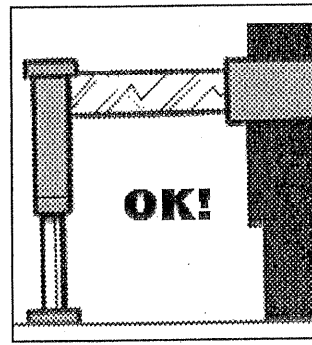
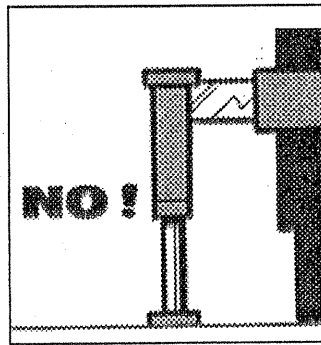
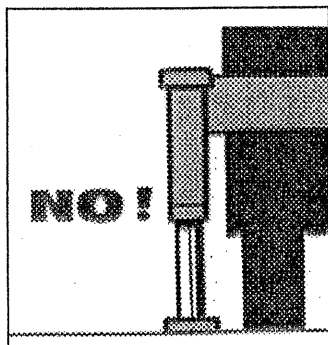
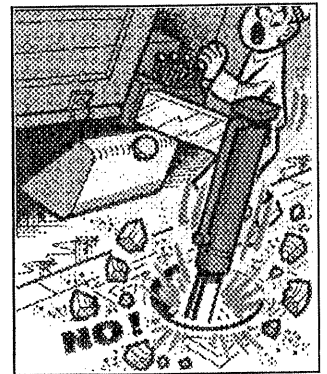

Should visibility be insufficient, make sure that control stations are properly lighted so as to ensure safety while operating control functions and allow reading of the plates.

Before manoeuvring a load check that the working area is adequate and properly lighted for your crane.

Make sure that the hook is always free to rotate on its pin and that nothing obstructs its vertical positioning. Check the efficiency of the hook safety catch.

Carefully inspect the load rigging and the condition of ropes or chains. Make sure that the lifted load is balanced.

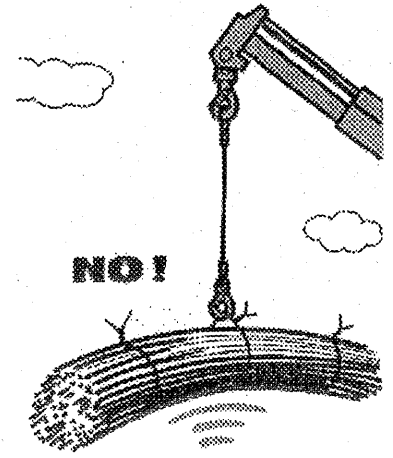
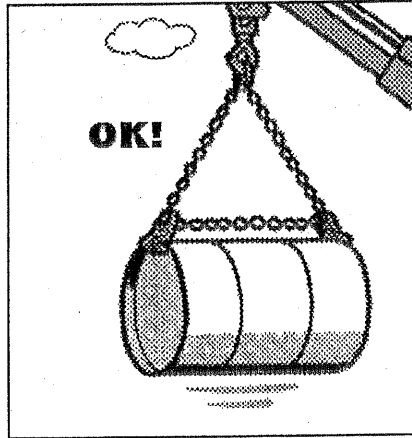
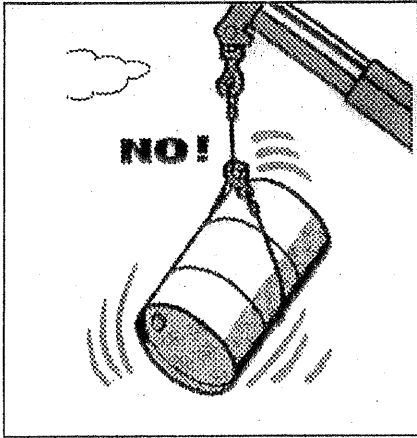

The pallet fork must be connected to the crane hook by means of a chain having at least 3 rings.

Hook up the load, checking that it does not exceed the capacity indicated on the lifting diagram specific to each load configuration.

It is absolutely prohibited to walk or stop under a suspended load and for unauthorized persons to be within the working area.

Avoid swinging the load above the control station.

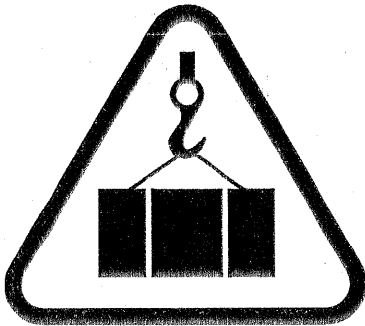
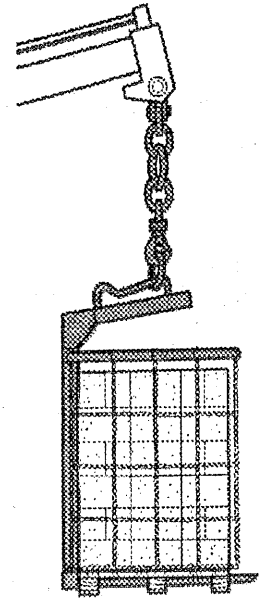

It is absolutely prohibited to load or unload under or in proximity of electric lines.

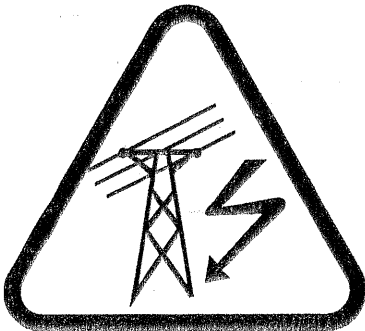

(!) The minimum distance from electric lines is, according to CEN norms, **5 meters**, except for otherwise prescribed by national norms.

For cranes with top seat controls, it is necessary to use a ladder to reach the control station.

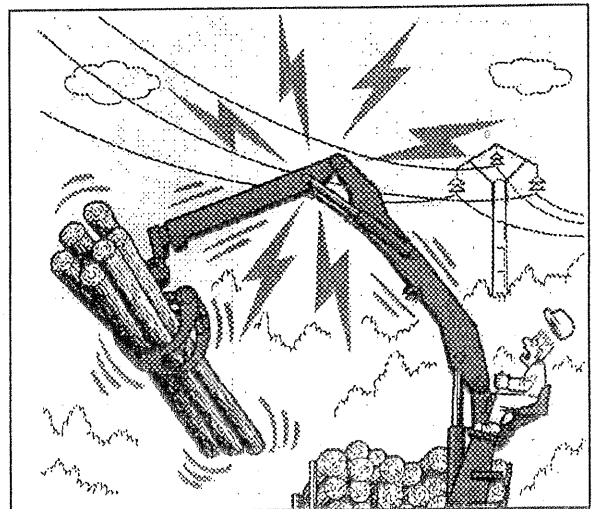

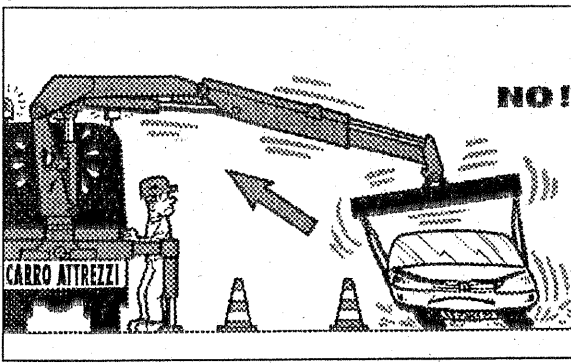

Do not rotate the crane before the load is lifted, do not operate with sudden movements, activate the controls with slow and progressive movements. Rotate slowly and with care paying attention to the stability of the vehicle. With vertical lift, on hydraulic and mechanical extension, rotate slowly in order to avoid side-skidding.

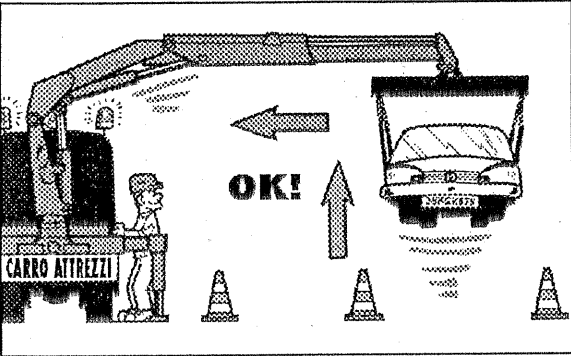

Do not move the vehicle if a load is suspended on the crane.

Do not utilize the crane for pull or push operations.

Under no circumstances interfere with the safety and protection devices.

At the end of the job and prior to driving the vehicle the crane must be folded. If the booms are to be laid on the body or on the load, they must be blocked to prevent possible sideways movements. Outrigger rams must be lifted and re-entered within the overall width of the truck and safety devices locked.

Check that the taps of the outrigger rams safety check valves are closed.

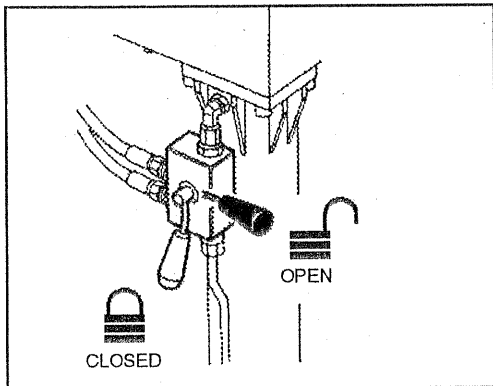

Disengage the power take off.

To avoid hitting bridges or tunnels check and record the overall height of your crane in the folded position or in laid position in the body or on the load. Always respect and pay proper attention to road signs placed in proximity of such obstacles.

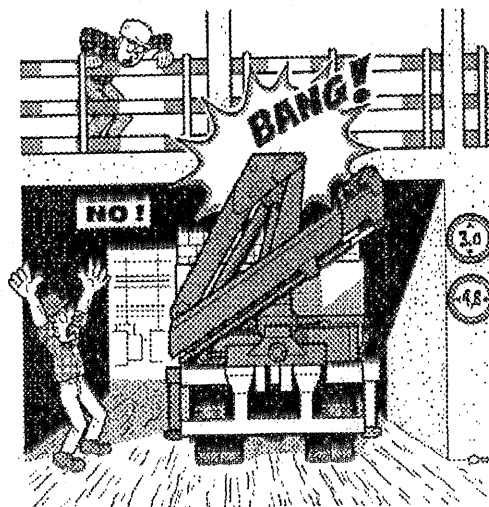
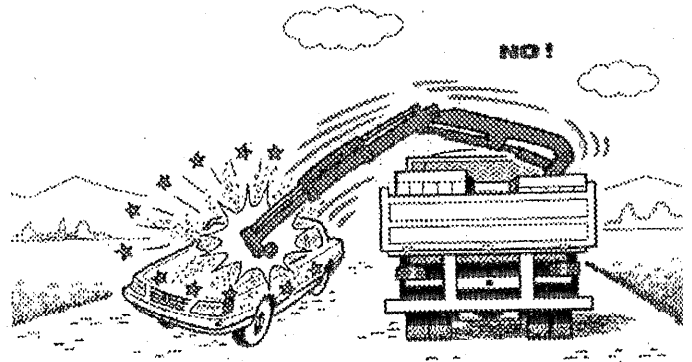

INSTRUCTIONS FOR CRANE USE

The use of the crane is reserved to authorized personnel, instructed in advance, who has to strictly conform to the safety norms and instructions contained in the instruction manual supplied with the crane.

- 1 — Only authorized persons are allowed to operate the crane.
- 2 — The crane must be used on firm, level ground.
- 3 — Check that the vehicle hand brake is on and that the wheels are chocked.
- 4 — Before every operation make sure that:
 - no-one is within the working area of the crane
 - the safety devices are in place and operative
 - the minimum safe working distances from power lines are observed.
- 5 — Stabilize the vehicle by the outrigger rams, making sure that:
 - the lateral supports are fully extended
 - the wheels are in contact with the ground and the suspension is not completely unloaded
 - the outriggers safety taps are closed.
- 6 — Use the crane in accordance with the use and maintenance manual, making sure that:
 - the load and radii are within the maximum limits shown on the crane capacity plate
 - the crane is used progressively avoiding sudden load movements
 - swinging or dragging of the load is avoided
 - the load is lifted before rotating.
- 7 — When using implements protect the crane working area with a barrier.
- 8 — The vehicle/crane are not left unless the power take off is disengaged and the load is on the ground.
- 9 — Before driving the vehicle make sure that the outriggers are fully retracted and re-entered, the safety taps closed and the crane is in folded position.

fig. 1

	FASSI GRU IDRAULICHE SpA 24021 ALBINO (BG) ITALY - Via dei Cornoliani, 2 Tel. + 39 35 77.40.00 - Fax + 39 35 75.50.20	INSTRUCTIONS FOR SAFE USE OF THE CRANE	DE1771
<ol style="list-style-type: none">1 Only authorized persons are permitted to operate the crane.2 The crane must be used on firm, level ground.3 Check that the vehicle hand brake is on and that the wheels are chocked.4 Before operation make sure that:<ul style="list-style-type: none">- no-one is within the working area of the crane;- the safety devices are in place and operative;- the minimum safe working distances from power lines are observed.5 Stabilize the vehicle with the outriggers, making sure that:<ul style="list-style-type: none">- the lateral supports are fully extended;- the wheels are in contact with the ground and the suspension is not completely unloaded;- the outriggers safety taps are closed.	<ol style="list-style-type: none">6 Use the crane in accordance with the use and maintenance manual, making sure that:<ul style="list-style-type: none">- the load and radii are within the maximum limits shown on the crane capacity plate;- the crane is used progressively avoiding sudden load movements;- swinging or dragging of the load is avoided;- the load is lifted before rotating.7 When using implements protect the working area with a barrier.8 The vehicle/crane are not left unless the power take off is disengaged and the load is on the ground.9 Before driving the vehicle ensure that the outriggers are fully retracted and re-entered, the safety taps closed and the crane is in the folded position.		

THESE INSTRUCTIONS FOR THE USE OF THE CRANE COINCIDE WITH THOSE OF THE PLATE DE1771 (FIG. 1) PLACED NEXT TO THE CRANE CONTROLS.

IDENTIFICATION OF THE CRANE MODEL

Essential data for the identification of the crane are given on the plate DE1661 used for the CE mark and fixed to the base. (Fig. 2)

- 1 — Crane model
- 2 — Serial Number
- 3 — Year of manufacturing

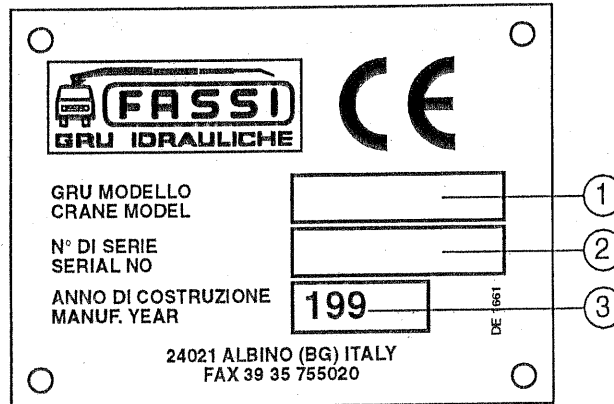
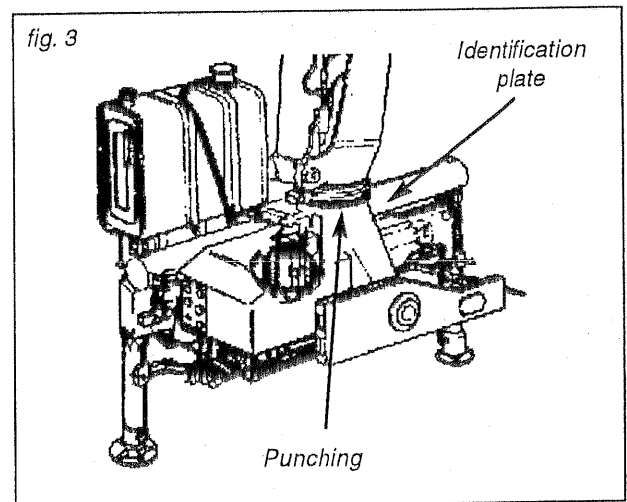
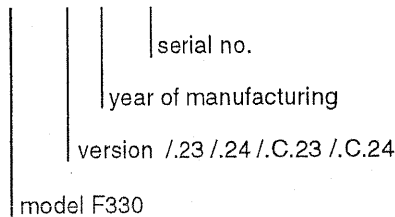

fig. 2

The model, the version of the crane, the year of manufacturing and the serial number are stamped on the base in the following sequence:

F330.22*2*0002



(!) UNDER NO CIRCUMSTANCES SHOULD THE DATA MARKED ON THE PLATE AND PUNCHED ON THE BASE BE ALTERED.

It is essential to give the correct **crane model** and **serial number**, when you contact the Service and Parts Department.

The exact **crane model**, **serial number** and description of **implements** will enable FASSI Service Department to give a rapid and efficient response.

A further metallic plate (fig.4) fixed to the crane by the installer, quotes the identifying data of the equipment and the final CE mark.

- 1 Name of the installer who applied the final CE mark
- 2 Crane mark, model and serial number
- 3 Vehicle mark, model and chassis number
- 4 Year of mounting

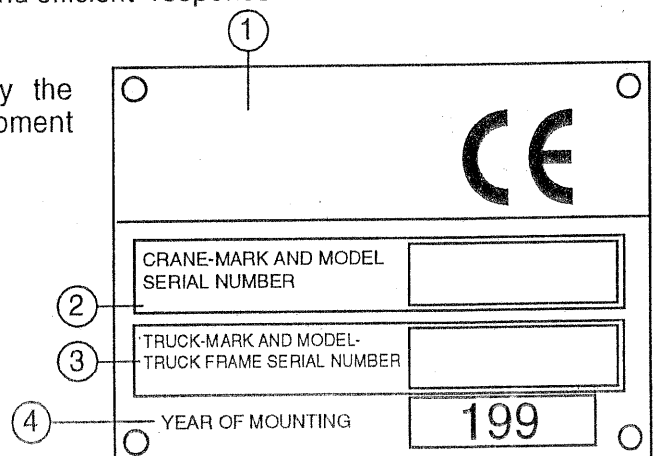

fig. 4

TECHNICAL DATA

The design of this crane has been carried out in respect of DIN 15018 norms, fatigue test classification H1B3 .

The crane can operate, intermittently, with lifting devices other than the hook. The dimensions and the capacity of the implements must be proportioned with crane performances.

F330.23

Lifting capacity	Standard reach	Hydraulic extension	Rotation arc	Rotation torque	Working pressure	Pump capacity	Oil tank capacity	Crane weight
tm 32,7	m 10,40	m 5,85	400°	KNm 52	Mpa 29	l/min 50	l180	Kg 3700

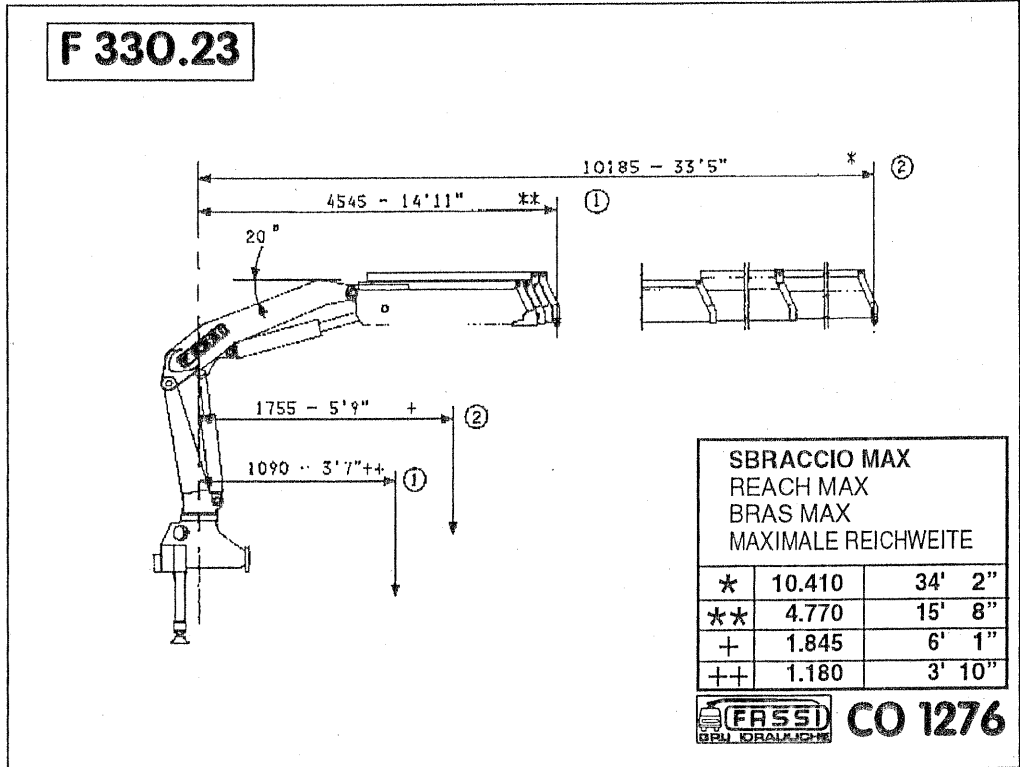

EXTRA			
A	2.300	7'	7"
B	2.300	7'	7"
C	2.268	7'	5"
D	6.868	22'	6"

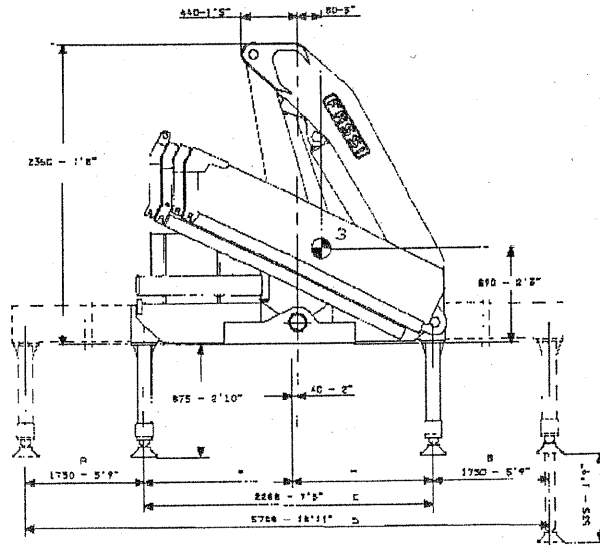

- MEZZERIA TIRANTI
 - FIXING ROD CENTER DISTANCE
 - LIGNE MEDIANE TIRANTS
 - ABMESSUNG DER BEFESTIGUNGSBRIDEN
- M39 x 3

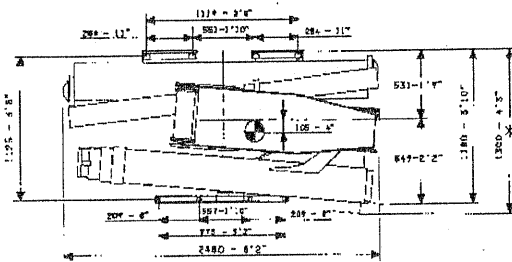

- PESI, DIMENSIONI E POSIZIONE BARYCENTRO.
- WEIGHT, DIMENSIONS AND BARYCENTRE POSITION.
- POIDS, DIMENSIONS ET POSITION DU BARYCENTRE.
- GEWICHTE, ABMESSUNG UND POSITION DES KRANSCHWERPUNKTE.

- * CON TUBAZIONI SUPPLEMENTARI
- * WITH SUPPLEMENTARY HOSES
- * AVEC TOUYAUTERIE SUPPLEMENTAIRE
- * MIT ZUSAEZTLICHEN SCHLAEUCHEN

F 330.23



CO 1271

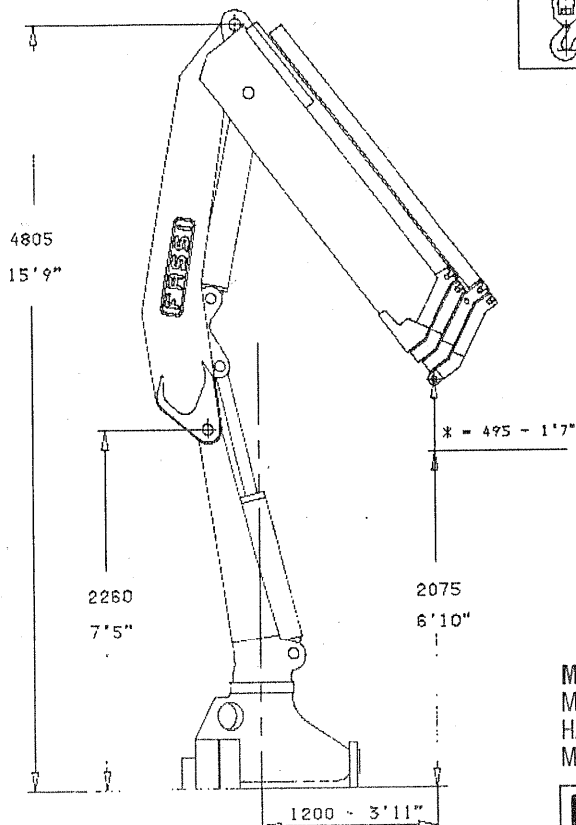
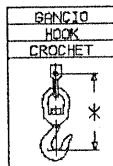

MASSIMA ALTEZZA SOTTOGANCIO.
MAXIMUM HOOKING POSITION.
HAUTEUR MAXIMUM SOUS CROCHET.
MAXIMALHOEHE BIS KRANHAKEN.

F 330.23 CO 1279



CRANE NOMENCLATURE

Version with ground controls for crane and outriggers and top seat controls for crane by hand cables (optional) (fig.5)

- | Pos. | Description |
|------|---|
| 1 | — Outrigger rams |
| 2 | — Outrigger supports with lateral hydraulic extension |
| 3 | — Base |
| 4 | — Rotation cylinders |
| 5 | — Distributor bank for crane |
| 6 | — Double control for crane |
| 7 | — Column |
| 8 | — Inner ram |
| 9 | — Inner boom |
| 10 | — Outer ram |
| 11 | — Outer boom |
| 12 | — Booms extension rams |
| 13 | — Extension boom sections |
| 14 | — Lifting hook |
| 15 | — Oil tank |
| 16 | — Manual extensions (optional) |
| 17 | — Seat (optional) |
| 18 | — Hand-cables for crane (optional) |

Version with ground controls for outriggers and top seat controls for crane (fig.6)

- | Pos. | Description |
|------|-----------------------------------|
| 1 | — Outrigger rams |
| 2 | — Outrigger supports |
| 3 | — Base |
| 4 | — Rotation cylinders |
| 5 | — Distributor bank for outriggers |
| 6 | — Double control for outriggers |
| 7 | — Column |
| 8 | — Seat |
| 9 | — Distributor bank for crane |
| 10 | — Inner ram |
| 11 | — Inner boom |
| 12 | — Outer ram |
| 13 | — Outer boom |
| 14 | — Booms extension rams |
| 15 | — Extension boom sections |
| 16 | — Lifting hook |
| 17 | — Oil tank |
| 18 | — Manual extensions (optional) |

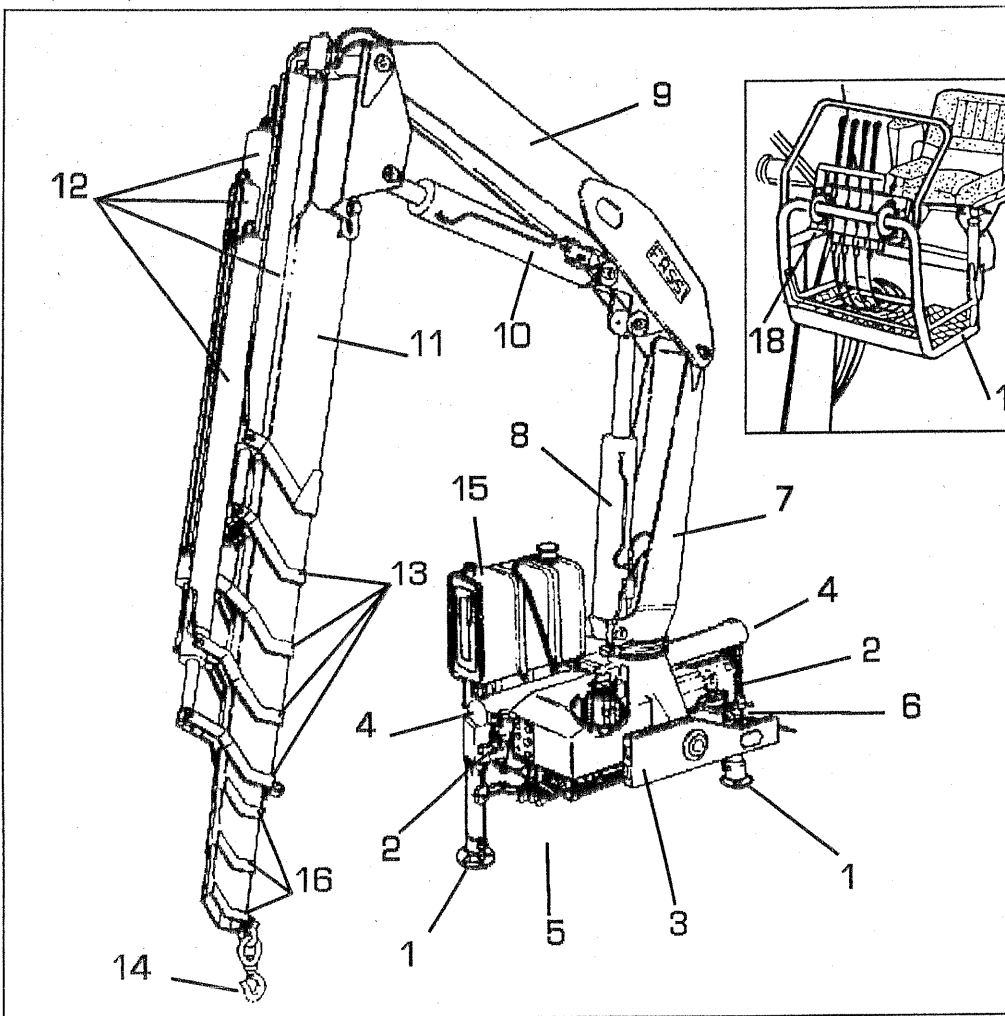

fig. 5

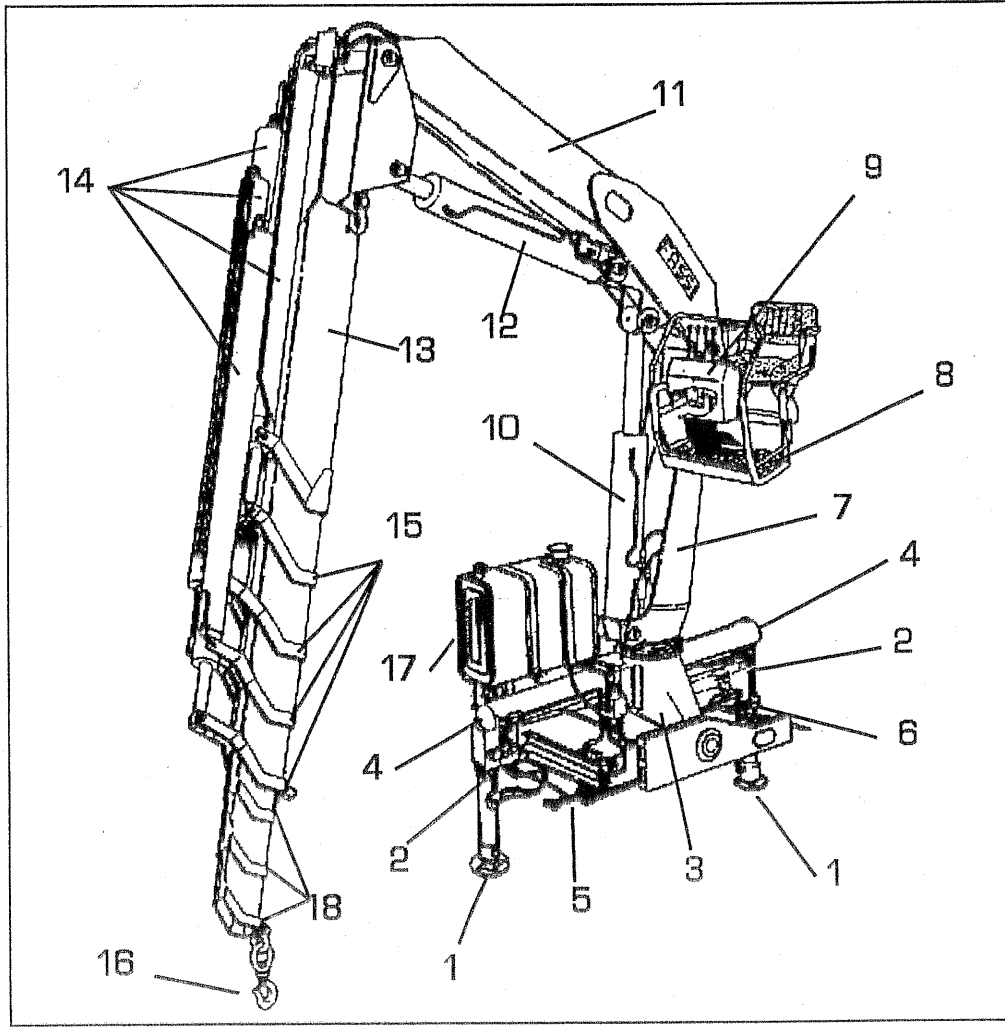

fig. 6

SAFETY AND PROTECTION DEVICES

Version with ground controls for crane and outriggers and top seat controls for crane by hand-cables (optional) (fig.7)

Pos.	Description
1	— Tap and check valve for outrigger rams
2	— Check valves for rotation control (flow regulators)
3	— Check valve for inner ram
4	— Check valve for outer ram
5	— Check valve for booms extension rams
6	— Lifting moment limiting device assembly
7	— Control panels
8	— Parachute valves
9	— Rotation limiting device
10	— Main pressure valve (crane)
11	— Auxiliary valves (crane)
12	— Levers guard
13	— Hook safety device
14	— Safety device for outriggers supports

Version with ground controls for outriggers and top seat controls for crane (fig.8)

Pos.	Description
1	— Tap and check valve for outrigger rams
2	— Check valves for rotation control (flow regulators)
3	— Check valve for rotation control
4	— Check valve for inner ram
5	— Check valve for outer ram
6	— Check valve for booms extension rams
7	— Lifting moment limiting device assembly
8	— Control panels
9	— Parachute valves
10	— Rotation limiting device
11	— Main pressure valve (outriggers)
12	— Main pressure valve (crane)
13	— Auxiliary valves (crane)
14	— Levers guard
15	— Hook safety device
16	— Safety device for outriggers supports

(!) Before crane use check that safety and protection devices are fitted and active.

(!) Under no circumstances interfere with the safety and protection devices.

(!) Interference with the check valves and removal of the lead seals remove the Manufacturer and invalidate the warranty.

(!) Use the ladder for the access to the top seat.

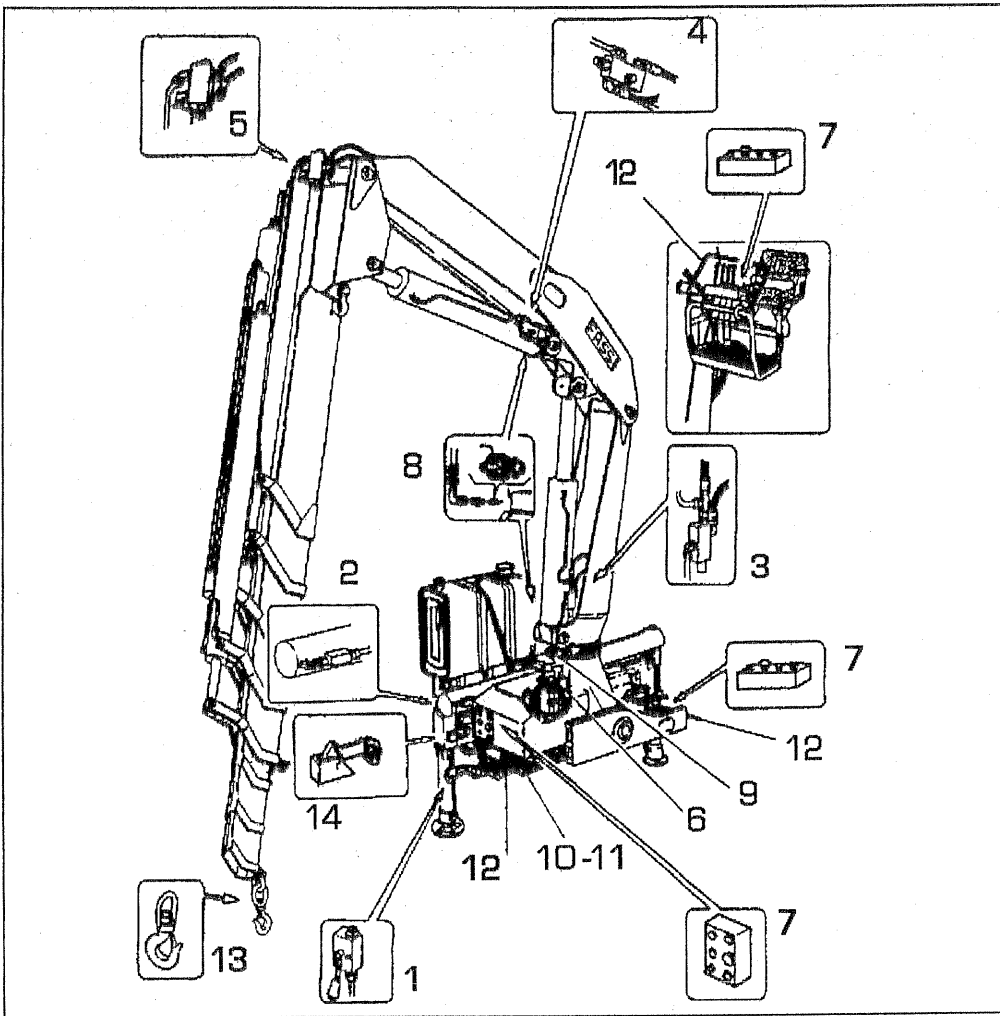

fig. 7

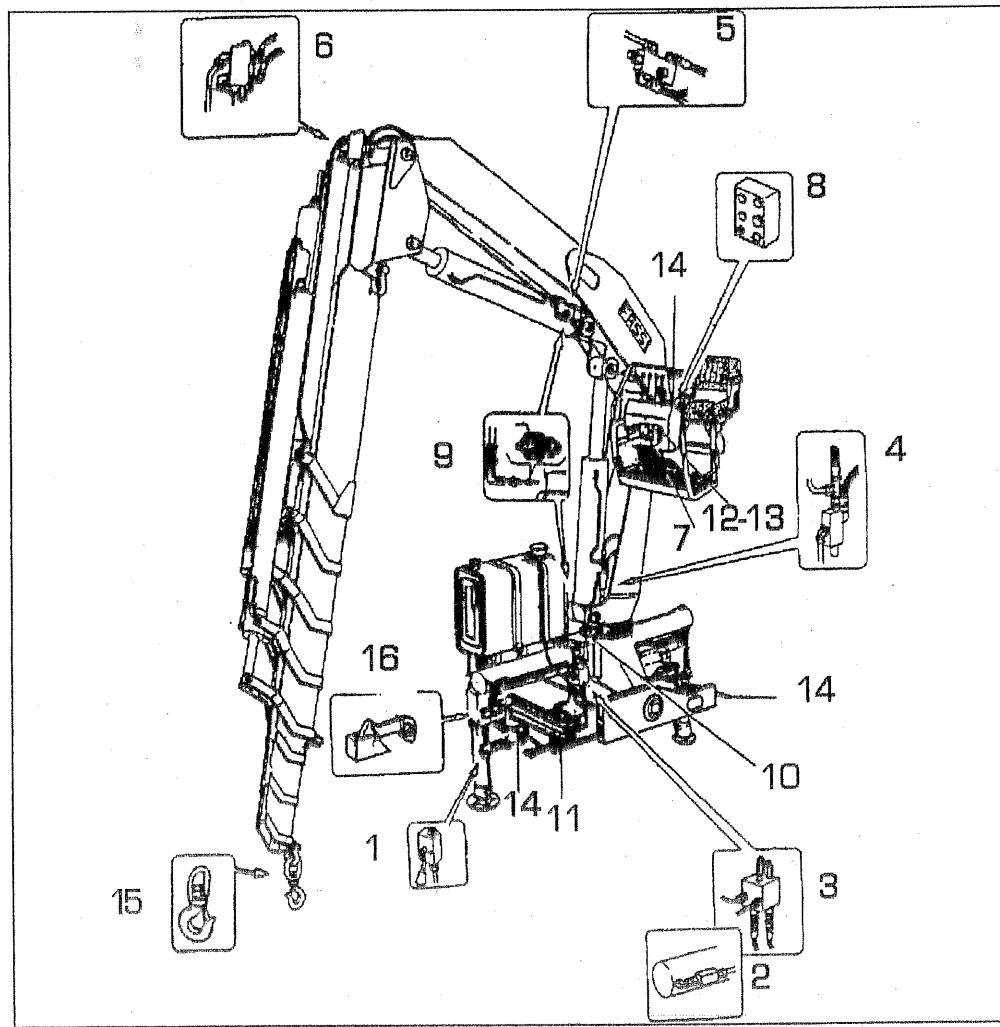

fig. 8

LIFTING MOMENT LIMITING DEVICE AND CONTROL PANELS

A characteristic which permits the classification of cranes is their lifting capacity or maximum lifting moment. The moment is defined by the value obtained from the product of the load to be lifted (in Kg) by its distance (in meters) from the centerline of the crane rotation.

The device called "lifting moment limiting device" preserves the crane structure from overloads, as it prevents any movement which increases the value of the moment.

Lifting moment limiting device "INTELLIGENT TYPE"

This device is fitted close to the distributor, whose specific functions it uses. It utilises an electrohydraulic technology, preventing any movement which causes an increase in the pressure induced by the load in the inner and outer rams of the crane (and in the outer ram for the hydraulic extension if fitted), up to the "critical values" which have been established in the structural test. These values, which are non-exceedable, determine the intervention levels and provide the data for setting the device.

The lifting moment limiting device concerns the following manoeuvres:

- Inner boom descent; the inner boom lift is controlled by the general main pressure valve of the distributor.
- Outer boom lift.
- Outer boom descent.
- Extension of extension boom sections.
- Winch rope lift (if fitted).
- If hydraulic extension is fitted: extension outer boom lift.
- Extension outer boom descent.
- Extension of the jib extension booms section.

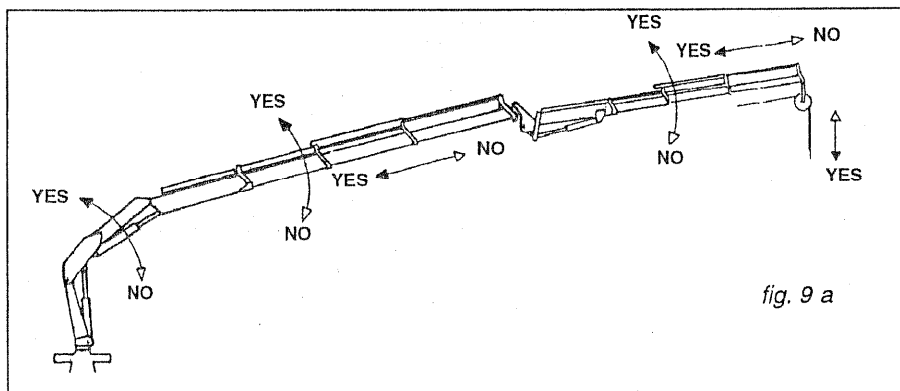

fig. 9 a

The device is based on hydraulic controls which are activated when the intervention value is reached and block the movements of the relevant distributor levers in one or both directions. Please remember that the device will return the lever of the element being used to neutral position. The condition of intervention is operated by the position of the outer boom (or, if

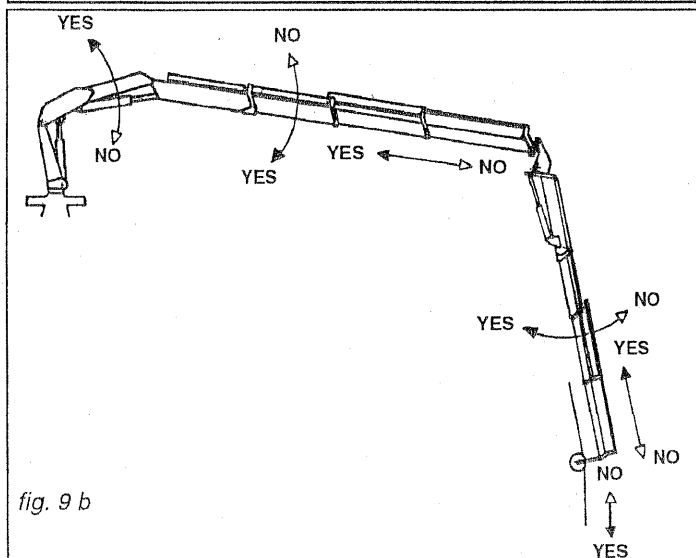
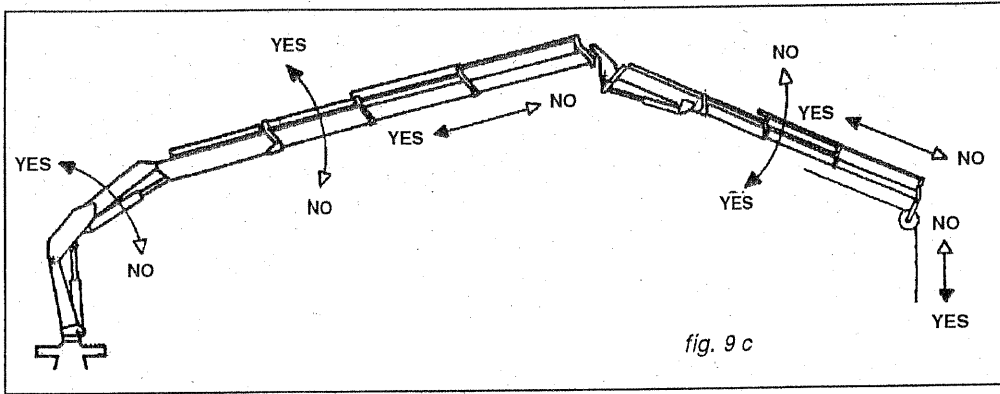

fig. 9 b

hydraulic extension is fitted, the position of the extension outer boom), on which the electronic signal position (mercury level switch) is read by a special electrovalve. This determines the controls of the locking or unlocking (resetting) of the controls concerned.

The crane configurations (fig. 9 a-b-c) (and the eventual hydraulic extension) indicate the manoeuvres which are allowed and not allowed by the device, in connection with the horizontal position of the crane and extension outer booms.



Control panels

The electric control panels are placed next to each control station.

Layout of the control panel (fig.10), positioned over the distributor.

- pos. 1 — Emergency stop button
- 2 — Audible alarm push button (danger)
- 3 — Orange warning light (90% of the capacity has been reached)
- 4 — Red warning light (activation of the limiting device)
- 5 — White warning light (power on)
- 6 — Fuse (10A)

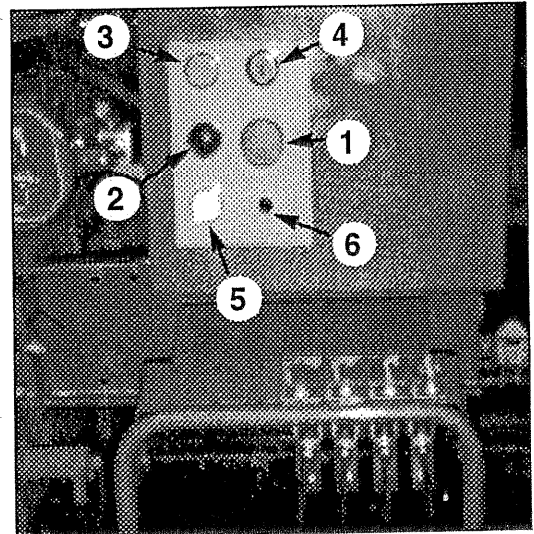

GROUND DISTRIBUTOR

fig. 10

Layout of the control panel (fig.11) positioned at the double control side (and at top seat in case of hand-cable controls)

- pos. 1 — Emergency stop button
- 2 — Audible alarm push button (danger)
- 3 — Orange warning light (90% of the capacity has been reached)
- 4 — Red warning light (activation of the limiting device)

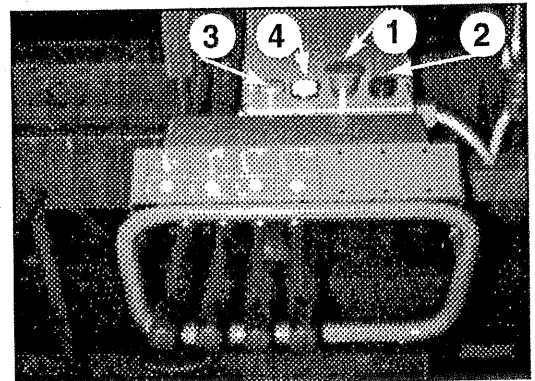

DOUBLE CONTROL SIDE

fig. 11

If the white warning light 5 comes on, it confirms that the electric circuit is active.

!NOTE! In the absence of electric power all crane functions will be de-activated.

If the orange warning light 3 comes on during load handling, 90% of the capacity (lifting moment) has been reached.

If during operation the red warning light 4 comes on, the activation value of the lifting moment limiting device has been reached.

The danger situation for persons must be audibly alarmed by pressing the push button 2.

When there are dangerous conditions for persons and things during load handling, operate on the emergency stop button 1, which isolates all crane functions.

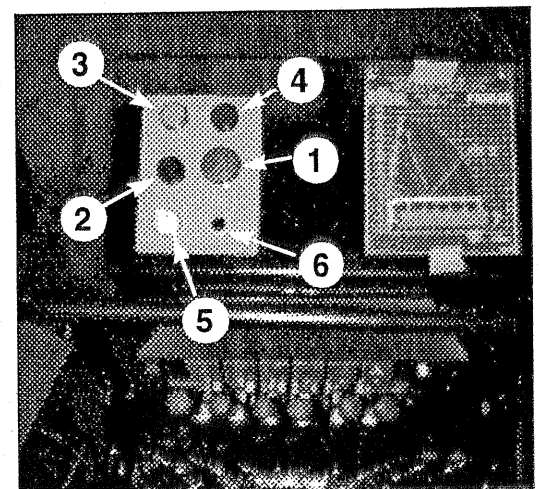

fig. 12
SEAT DISTRIBUTOR

(!) Every device is installed with an exclusion tap (fig. 13 and 14), which permits the re-activation of all crane functions in the event of loss of electric power supply. Only in these situations it is permitted to remove the lead seals which protect the tap lever in the closed position.

Crane with ground distributor

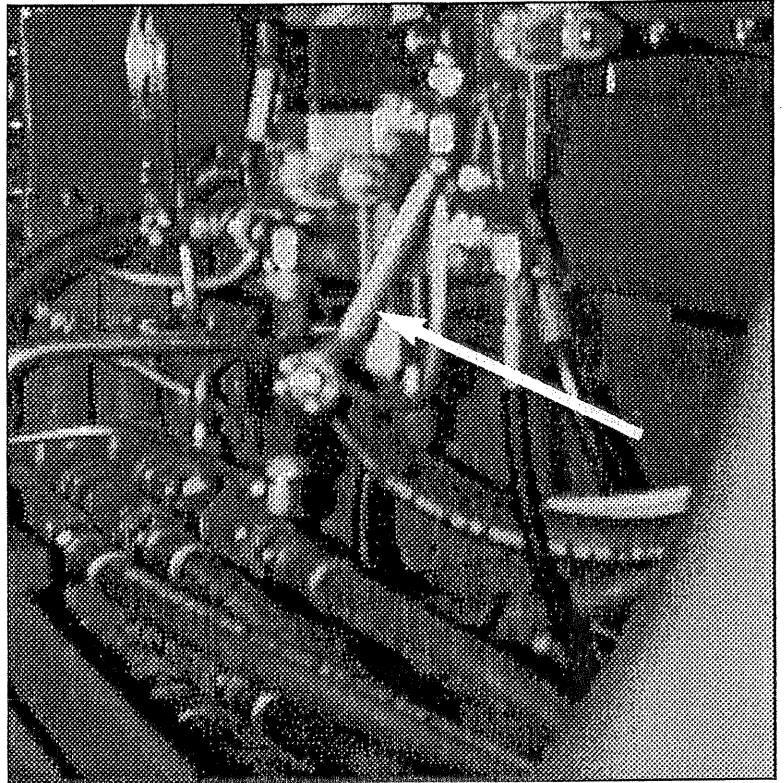

fig. 13

Crane with seat distributor

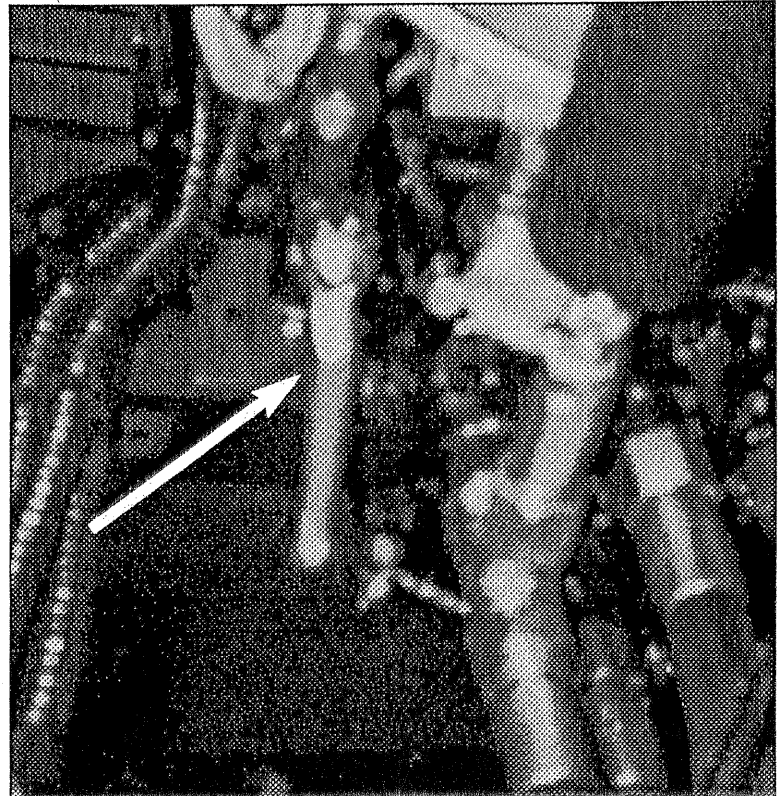

fig. 14

EMERGENCY exclusion tap

Every electrovalve is installed with a screwed tap (emergency exclusion tap), which must only be used in case of emergency, testing or other abnormal situations when it is not possible to carry out any of the movements allowed by the device. Only in these situations it is permitted to remove the lead seals which protect the device. Firstly remove the protection guard. Then unscrew the three base fixing screws and the four seat fixing screws (13 mm hexagonal spanner). Slacken the lock nut of the screwed tap (fig. 15 e 16) (14 mm hexagonal spanner), completely screw in the tap (5 mm allen key) and re-tighten the lock nut.

After such emergency operations and prior to re-use of the crane, you must immediately go to FASSI authorised Agent for testing the structure and re-sealing of the device.

(!) Interferences with the valves or removal of the lead seals release the Manufacturer from any responsibility and invalidate the warranty.

(!)ATTENTION(!)

The presence of the lifting moment limiting device does not release the user from the obligation to respect what is indicated on capacity plates and lifting curves.

Crane with ground distributor

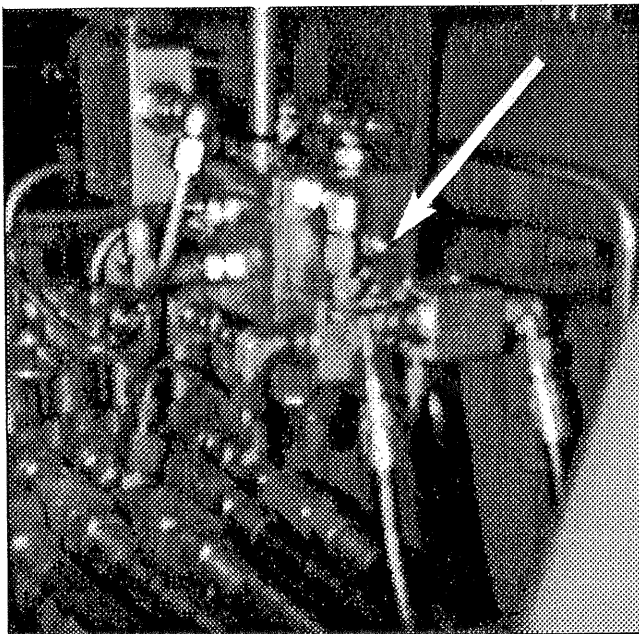

fig. 15

Crane with top seat distributor

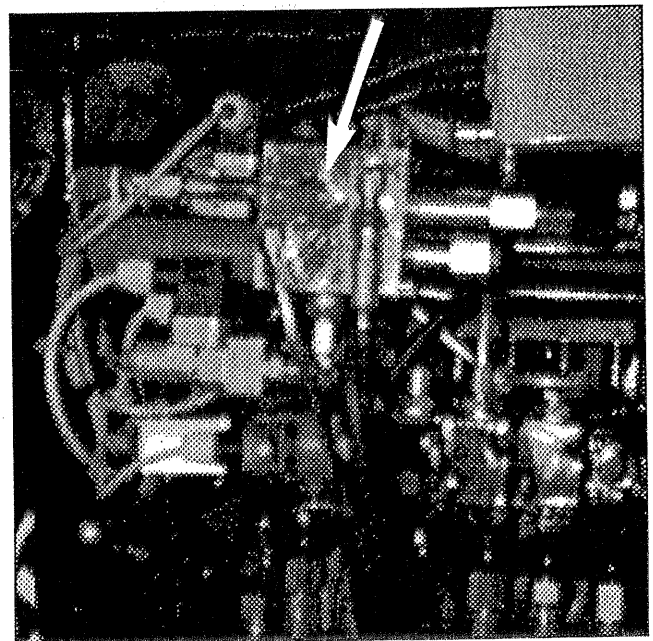

fig. 16

ROTATION LIMITING DEVICE

When a sector of the working area exists in which the stability is insufficient (for example in the area in front of the cab) the permitted arc of rotation is limited by means of an adjustable electro-hydraulic device which only allows operation within the safe area.

When exceeding the "safe area" the rotation limiting device only allows manoeuvres which reverse the direction of rotation.

If a reduction of capacity is necessary because of insufficient stability of the complete unit, new capacity plates must be fixed giving the derated capacity in accordance with the final stability test.

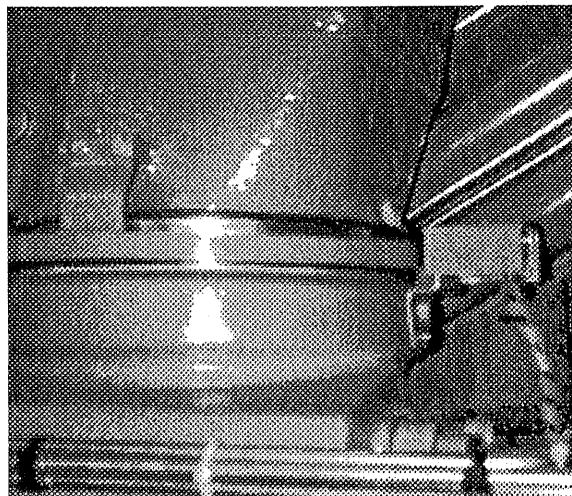

fig. 16 a