



# series 3500

## BOOM TRUCKS

### features

- 35 Ton (31,8 mton) Capacity
- 5-Section 124' (37,8 m) Proportional Boom
- 4-Section 100' (30,5 m) Proportional Boom
- 3-Section 77' (23,5 m) Proportional Boom
- 1 and 2-Section 30' 6" (9,3 m) to 55' (16,8 m) Jib
- 165' 11" (50,6 m) Maximum Tip Height
- 22', 1.25" (6,7 m) Out-and-Down Outriggers at Full Extension
- Intermediate and Fully Extended Outrigger Charts are Standard
- FirstUp for Optional Front Stabilizer Auto Retract
- 2-Speed Planetary Hoist with Grooved Drum and Negative Draft Flange
- Load Moment Indicator with Digital Display, CAN Bus, Overload Shutdown and Internal Boom Length Cable
- Radio ATB
- Rugged, Weatherproof Electrical System with Circuit Status LEDs
- Removable Boom Rest
- System Pressure Gauge
- Clamp-On Mounting
- Aeroquip STC (Snap to Connect) Hydraulic Fittings
- ManiTex UPTIME Comprehensive Support



product guide

# series 3500

## GENERAL SPECIFICATIONS

### BOOM

**Booms** – Inverted T-cross section, 3, 4, or 5-section telescoping type, extended and retracted proportionally by a double-acting hydraulic cylinder and cable-crowd system. **35100** – 4-Section 30' 6" (9,3 m) to 100' 0" (30,5 m). 2-section, 31' (9,5 m) to 55' (16,8 m) jib. **35124C** – 5-section 31' 5/8" (9,5 m) to 123' 8 5/8" (37,7 m). 1-section, 31' (9,5 m) jib. **3577C** – 3-section, 29' 5" (9 m) to 77' (23,5 m).

**Quick Reeve Boom Point** – Three high-density nylon load sheaves mounted on heavy-duty roller bearings. Two removable pin-type rope guards.

**Boom Elevation** – Double-acting hydraulic cylinder. Working range from 10 $\uparrow$  below horizontal to 80 $\uparrow$  above.

**Load Hook** – 5-ton (4,5 mton) capacity hook with heavy-duty swivel and weight is provided for single-line operation.

### HOIST

**Hoist** – Maximum theoretical line speed 453 fpm (138 mpm). Maximum theoretical bottom-layer line pull 14,500 lb (6 577 kg). Two-speed planetary reducer. Wet multi-disc internal brake is spring-applied, pressure-released.

**Wire Rope** – 380' (115,8 m) of 5/8" (16 mm) rotation resistant type.

### SWING SYSTEM

Externally mounted, double-reduction planetary driven by hydraulic motor. Maximum theoretical swing speed 1.5 rpm. Wet multi-disc internal brake is spring-applied, pressure-released. Oversized diameter ball-bearing swing circle with external gear. 372 $\uparrow$  non-continuous rotation.

### OUTRIGGERS

Out-and-down style outriggers, operated independently for precise leveling. 22' 1 1/4" (6,8 m) spread at full extension and 13' 4" (4,1 m) spread at intermediate extension. 16" (406 mm) diameter floats. Bubble level located near outrigger controls.

### STABILIZERS

8' (2,4 m) retracted; 18' 6" (5,6 m) extended. Operated independently for precise leveling. Double-acting hydraulic cylinders. Fixed pad size is 12" (305 mm) diameter.

### MOUNTING

**Mounting** – Pedestal and subframe are mounted to chassis by threaded rods and clamp plates. No welding, drilling, or bolting to truck frame is required.

**Subframe** – Torsionally resistant, rigid 4-plate design. Mounted under crane full length of truck frame.

**Rear Underride Protection** – Supplied on factory-mounted cranes. Fabricated structure mounted under rear of bed. Complies with Bureau Motor Carrier Safety Standard 393.86.

**Boom Rest** – Heavy-duty fabrication. Easily removed to simplify loading and unloading truck deck.

### CONTROL SYSTEM

Dual operator platforms are equipped with four single-lever crane controls arranged to ANSI B30.5 standards. Fully proportional control valves and system pressure gauge. Each station also includes outrigger and stabilizer controls, engine start/stop, foot throttle, signal horn, boom-angle indicator, bubble levels, beverage container, load chart and range diagram.

### HYDRAULICS

**Hydraulic System** – A 3-section vane pump direct-mounted to power take-off on truck transmission provides 38 gpm (145 lpm) to the hoist, 27 gpm (102 lpm) to the boom hoist and telescope circuit, and 11 gpm (45 lpm) to the swing and outrigger circuit. 100-gallon (379-liter) baffled reservoir includes suction ball valve with strainer two 25-micron filters in the return line. Use of SAE O-ring and face seal O-ring hydraulic fittings throughout system. Aeroquip STC (Snap-to-Connect) on all hoses up to 1" virtually

eliminates leaks.

**Hydraulic Cylinders** – All load-holding cylinders are equipped with integral holding valves.

### WARNING SYSTEMS

**Load Moment Indicator** – CAN bus system maximizes expansion capabilities. Senses boom hoist cylinder pressure, boom length and boom angle. Audio-visual warning indicated overload conditions and overload shutoff feature prevents continuing overload. Operator can access all relative crane configuration and load conditions via display at the operator station. Internal boom length cable.

**Radio Anti-Two-Block System** – Audible warning and shutoff functions prevent hook from contacting boom point. Switch is potted to ensure reliability.

**Back-Up Alarm** – Supplied on factory-mounted cranes, electronic audible motion alarm activated when truck transmission is in reverse gear.

### GENERAL

**Electrical** – State-of-the-art, weather-resistant components throughout. Hermetically sealed power in relays. Enclosure includes power in relays and circuit status LEDs. Designed to withstand high pressure washing and varying climates.

**Design/Welding** – Design conforms to ANSI B30.5. Welding conforms to AWS D1.1. Tested to SAE 1063 and SAE 765.

**Manuals** – Operator, service and parts manuals depict correct crane operation, maintenance procedures and parts listing.

**Warranty** – 12-month warranty covers parts and labor resulting from defects in material and workmanship.

\* In order to ensure continuous improvement, specifications may change without notice.

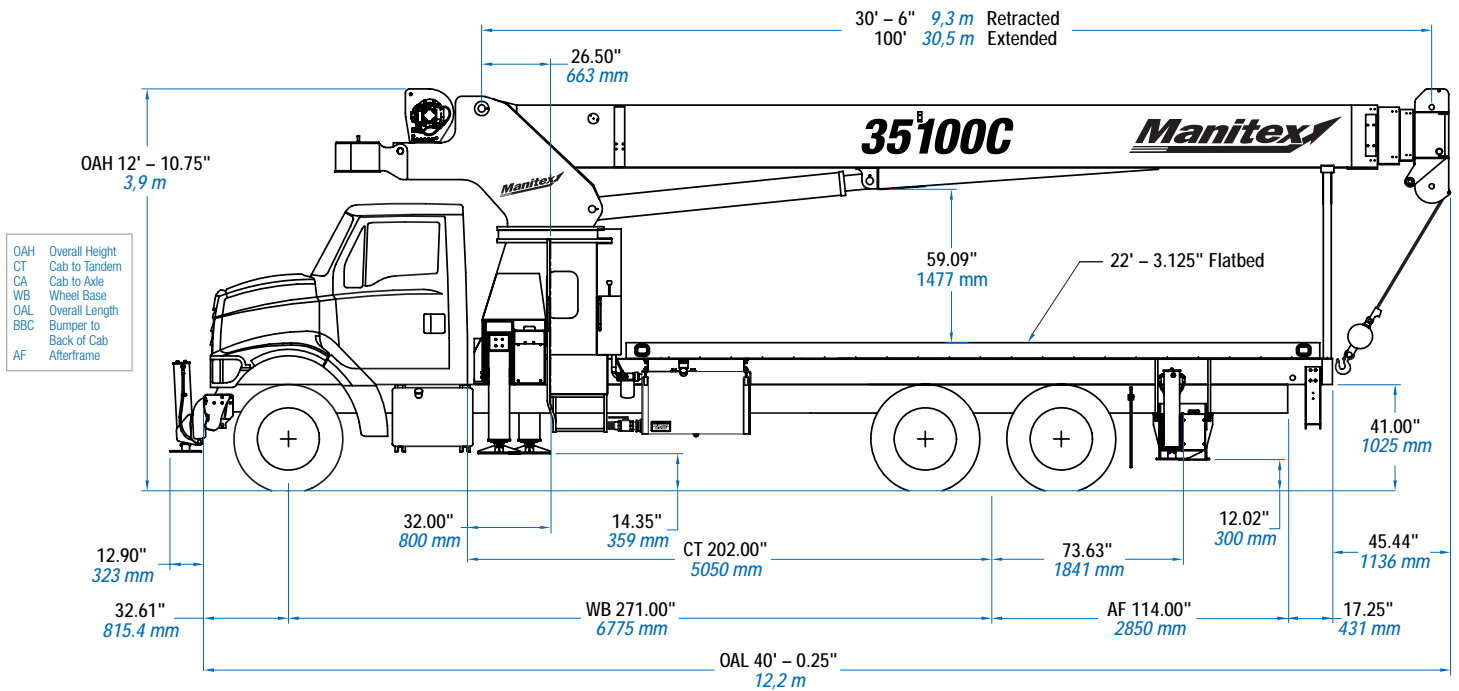

| CHASSIS DATA                                    | 35100C/35124C  |
|---|--|
| Wheelbase (WB)                                  | <b>271"</b><br><b>6 883 mm</b>   |
| Cab to Tandem (CT)                              | <b>202"</b><br><b>4 877 mm</b>   |
| After Frame (AF)                                | <b>114"</b><br><b>2 896 mm</b>   |
| Frame Section Modulus at 180° Area of Operation | <b>30.0 in<sup>3</sup></b><br><b>125,000 psi</b><br><b>861 875 kPa</b> |
| Frame Section Modulus at 360° of Operation      | <b>30.0 in<sup>3</sup></b><br><b>125,000 psi</b><br><b>861 875 kPa</b> |
| Front Axle Gross Weight Rating                  | <b>20,000 lb</b><br><b>8 165 kg</b>                                    |
| Rear Axle Gross Weight Rating                   | <b>40,000 lb</b><br><b>18 144 kg</b>                                   |
| Minimum Truck Axle Weight - Front**             | <b>8,450 lb</b><br><b>3 674 kg</b>                                     |
| Minimum Truck Axle Weight - Back**              | <b>8,300 lb</b><br><b>3 765 kg</b>                                     |
| Nominal Frame Width                             | <b>34"</b><br><b>864 mm</b>  |

\*Frame section modulus at 360P area of operation requires front bumper stabilizer.  
 \*\*Minimum chassis weight is required to meet 85% stability requirements.  
 Chassis data is general – not for engineering. Some dimensions depend on truck selection.

| MAXIMUM TIP HEIGHT     | 35100C                            | 35124C                            |
|------------------------|-----------------------------------|-----------------------------------|
| Configuration          | <b>Boom 100'</b><br><b>30,5 m</b> | <b>Boom 124'</b><br><b>37,8 m</b> |
| Extended Boom          | <b>111' 4"</b><br><b>33,9 m</b>   | <b>134' 8"</b><br><b>41,1 m</b>   |
| Fixed or Retracted Jib | <b>142' 1"</b><br><b>43,3 m</b>   | <b>165' 11"</b><br><b>50,6 m</b>  |
| Extended Jib           | <b>166' 8"</b><br><b>50,8 m</b>   | —                                 |

| WEIGHTS  | 35100C                               | 35124C                               |
|--|--------------------------------------|--------------------------------------|
| Total Crane - Out-and-Down Outriggers          | <b>29,706 lb</b><br><b>13 502 kg</b> | <b>31,126 lb</b><br><b>14 148 kg</b> |
| 22' (6,71 m) Flat Bed                          | <b>2,000 lb</b><br><b>907 kg</b>     | <b>2,000 lb</b><br><b>907 kg</b>     |
| 30' 6" (9,30 m) Fixed Length Jib               | <b>1,126 lb</b><br><b>511 kg</b>     | —                                    |
| 31' (9,45 m) Fixed Length Jib                  | —                                    | <b>850 lb</b><br><b>386 kg</b>       |
| 30' 6" – 55' (9,30 m – 16,80 m) Telescopic Jib | <b>1,754 lb</b><br><b>796 kg</b>     | —                                    |

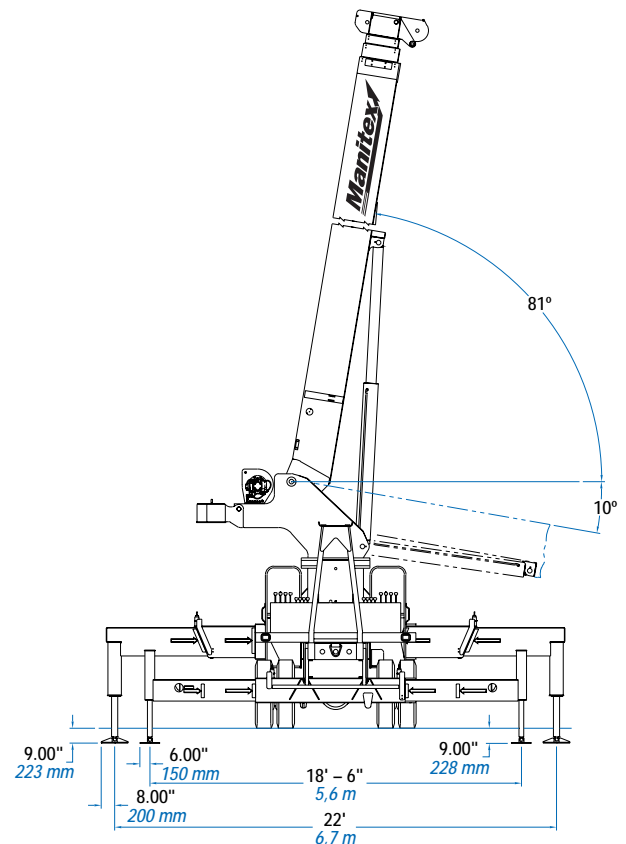

USE THIS CHART ONLY WHEN  
OUTRIGGERS AND STABILIZERS ARE  
FULLY EXTENDED.

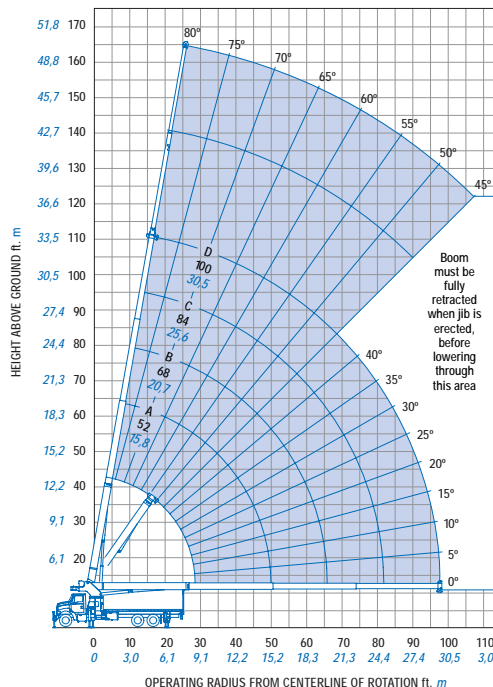
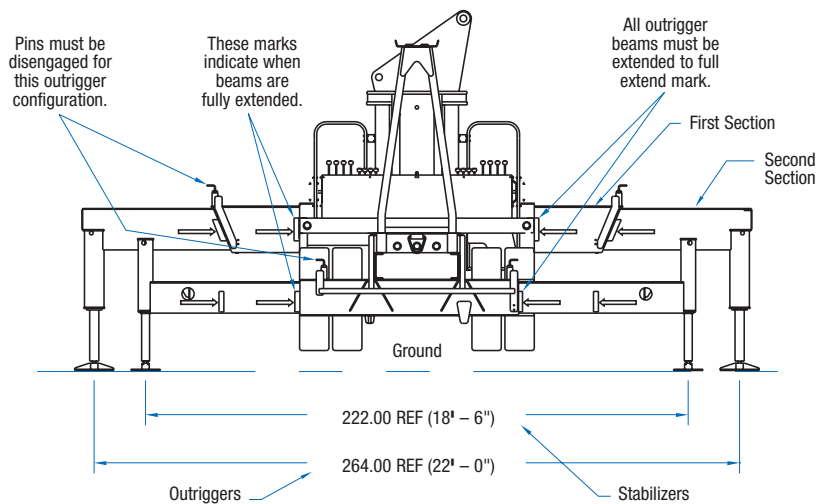

### FULLY EXTENDED OUTRIGGER SPREAD: MODEL 35100C

#### MAIN BOOM LOAD RATINGS

#### JIB LOAD RATINGS

| Operating Radius | Boom Length              |        | A                       |        | B                       |        | C                       |     | D                        |        | Fixed Jib                |        | Telescopic Jib                    |     |                         |       |     |     |
|------------------|--------------------------|--------|-------------------------|--------|-------------------------|--------|-------------------------|-----|--------------------------|--------|--------------------------|--------|-----------------------------------|-----|-------------------------|-------|-----|-----|
|                  | 30.5 Feet<br>9,29 Meters |        | 52 Feet<br>15,84 Meters |        | 68 Feet<br>20,72 Meters |        | 84 Feet<br>38,18 Meters |     | 100 Feet<br>30,48 Meters |        | 30.5 Feet<br>9,29 Meters |        | 30.5 Feet<br>9,29 Meters          |     | 55 Feet<br>16,76 Meters |       |     |     |
|                  | Feet                     | Meters | lb.                     | kg.    | lb.                     | kg.    | lb.                     | kg. | lb.                      | kg.    | lb.                      | kg.    | lb.                               | kg. | lb.                     | kg.   |     |     |
| 6                | 1,82                     | 80°    | 70,000                  | 31 818 |                         |        |                         |     |                          |        |                          |        |                                   |     |                         |       |     |     |
| 8                | 2,43                     | 76°    | 53,500                  | 24 318 |                         |        |                         |     |                          |        |                          |        |                                   |     |                         |       |     |     |
| 10               | 4,04                     | 72°    | 45,670                  | 20 759 |                         |        |                         |     |                          |        |                          |        |                                   |     |                         |       |     |     |
| 12               | 3,65                     | 68°    | 39,830                  | 18 104 | 78                      | 31,500 | 14 318                  |     |                          |        |                          |        |                                   |     |                         |       |     |     |
| 15               | 4,57                     | 61°    | 33,660                  | 15 300 | 75                      | 30,330 | 13 786                  | 79  | 28,500                   | 12 954 |                          |        |                                   |     |                         |       |     |     |
| 20               | 6,09                     | 49°    | 24,380                  | 11 036 | 69                      | 23,790 | 10 813                  | 75  | 22,580                   | 10 263 | 79                       | 21,780 | 9 900                             | 80  | 14,000                  | 6 363 |     |     |
| 25               | 7,62                     | 33°    | 18,310                  | 8 322  | 62                      | 18,810 | 8 550                   | 70  | 18,470                   | 8 395  | 75                       | 17,690 | 8 040                             | 78  | 13,500                  | 6 136 |     |     |
| 30               | 9,14                     |        |                         |        | 56                      | 14,700 | 6 681                   | 65  | 14,850                   | 6 750  | 71                       | 14,760 | 6 709                             | 75  | 13,000                  | 5 909 |     |     |
| 35               | 10,66                    |        |                         |        | 48                      | 11,350 | 5 159                   | 60  | 11,530                   | 5 240  | 67                       | 11,630 | 5 286                             | 72  | 11,700                  | 5 318 |     |     |
| 40               | 12,19                    |        |                         |        | 40                      | 8,910  | 4 050                   | 55  | 9,070                    | 4 122  | 63                       | 9,170  | 4 168                             | 69  | 9,240                   | 4 200 |     |     |
| 45               | 13,71                    |        |                         |        | 29                      | 7,120  | 3 236                   | 50  | 7,290                    | 3 313  | 59                       | 7,380  | 3 354                             | 66  | 7,440                   | 3 381 |     |     |
| 50               | 15,24                    |        |                         |        |                         |        |                         | 43  | 5,930                    | 2 695  | 55                       | 6,020  | 2 736                             | 62  | 6,080                   | 2 763 |     |     |
| 55               | 16,76                    |        |                         |        |                         |        |                         | 36  | 4,860                    | 2 209  | 51                       | 4,950  | 2 250                             | 59  | 5,000                   | 2 272 |     |     |
| 60               | 18,28                    |        |                         |        |                         |        |                         | 27  | 3,990                    | 1 813  | 46                       | 4,080  | 1 854                             | 55  | 4,140                   | 1 881 |     |     |
| 65               | 19,81                    |        |                         |        |                         |        |                         | 12  | 3,280                    | 1 490  | 40                       | 3,370  | 1 531                             | 51  | 3,430                   | 1 559 |     |     |
| 70               | 21,33                    |        |                         |        |                         |        |                         |     |                          |        | 34                       | 2,770  | 1 259                             | 47  | 2,830                   | 1 286 |     |     |
| 75               | 22,86                    |        |                         |        |                         |        |                         |     |                          |        | 27                       | 2,270  | 1 031                             | 43  | 2,320                   | 1 054 |     |     |
| 80               | 24,38                    |        |                         |        |                         |        |                         |     |                          |        | 15                       | 1,830  | 831                               | 38  | 1,880                   | 854   |     |     |
| 85               | 25,90                    |        |                         |        |                         |        |                         |     |                          |        |                          | 33     | 1,500                             | 681 | 52                      | 1,680 | 763 |     |
| 90               | 27,43                    |        |                         |        |                         |        |                         |     |                          |        |                          | 26     | 1,170                             | 531 | 49                      | 1,350 | 613 |     |
| 95               | 28,96                    |        |                         |        |                         |        |                         |     |                          |        |                          | 17     | 870                               | 395 | 45                      | 1,050 | 477 |     |
| 100              | 30,48                    |        |                         |        |                         |        |                         |     |                          |        |                          |        |                                   |     | 42                      | 790   | 359 |     |
| 105              | 32,00                    |        |                         |        |                         |        |                         |     |                          |        |                          |        |                                   |     | 38                      | 550   | 250 |     |
| 110              | 33,52                    |        |                         |        |                         |        |                         |     |                          |        |                          |        |                                   |     |                         | 47    | 560 | 254 |
|                  |                          |        | 600                     | 273    | 350                     | 159    | 270                     | 123 | 220                      | 100    | 180                      | 82     | Deductions: Stowed Fixed Jib      |     |                         |       |     |     |
|                  |                          |        | 900                     | 409    | 530                     | 241    | 400                     | 182 | 330                      | 150    | 290                      | 132    | Deductions: Stowed Telescopic Jib |     |                         |       |     |     |

Meets ANSI B30.5 Requirements - Do not operate crane or accessories within 10' (3,05m) of live power lines.

NOTICE: This chart is for reference only and must not be used for lifting purposes. Consult factory for other boom options.

## AREA OF OPERATION

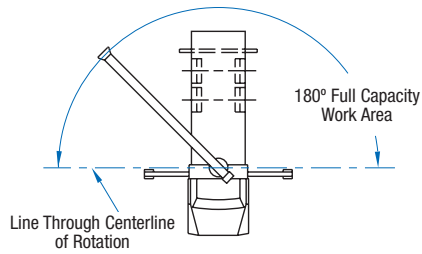

## DEDUCTIONS

|                            |   |
|----------------------------|---|
| Auxiliary Block            | <b>50 lb</b><br><b>22.72 kg</b>                 |
| Load Block                 | <b>See block manufacturer nameplate</b>         |
| Overhaul Ball              | <b>See overhaul ball manufacturer nameplate</b> |
| Hose Reel                  | <b>260 lb</b><br><b>118.18 kg</b>               |
| Swing Around Jib* (Stowed) | <b>See load rating chart</b>                    |

## WEIGHTS

| 1 Part Line                        | 2 Part Line                         | 3 Part Line                          | 4 Part Line                          | 5 Part Line                          | 6 Part Line                          | 7 Part Line                          | 8 Part Line                          | <b>WARNING</b>   |
|------------------------------------|-------------------------------------|--------------------------------------|--------------------------------------|--------------------------------------|--------------------------------------|--------------------------------------|--------------------------------------|--|
|                                    |                                     |                                      |                                      |                                      |                                      |                                      |                                      | <p>Anti-two-block system must be in good operating condition before operating crane. Refer to the owner's manual. Keep at least three wraps of load line on the drum at all times.</p> <p>.625" rot resistant (5.0:1 SF) - 45400 lb. min. breaking strength</p> <p>.625" 6 x 25 IWRC (3.5:1 SF) - 33250 lb. min. breaking strength</p> |
| <b>9,080 lb</b><br><b>4 127 kg</b> | <b>18,160 lb</b><br><b>8 254 kg</b> | <b>27,240 lb</b><br><b>1 238 kg</b>  | <b>36,320 lb</b><br><b>16 509 kg</b> | <b>45,400 lb</b><br><b>20 636 kg</b> | <b>54,480 lb</b><br><b>24 763 kg</b> | <b>63,560 lb</b><br><b>28 890 kg</b> | <b>70,000 lb</b><br><b>31 818 kg</b> |  |
| <b>9,500 lb</b><br><b>4 318 kg</b> | <b>19,000 lb</b><br><b>8 636 kg</b> | <b>28,500 lb</b><br><b>12 954 kg</b> | <b>38,000 lb</b><br><b>17 272 kg</b> | <b>47,500 lb</b><br><b>21 590 kg</b> | <b>57,000 lb</b><br><b>25 909 kg</b> | <b>66,500 lb</b><br><b>30 227 kg</b> | <b>70,000 lb</b><br><b>31 818 kg</b> |  |

## BOOM AND JIB COMBINATIONS

|        |             |                |                          |
|--------|-------------|----------------|--------------------------|
| 3577C  | 77' Powered | 3 Section Boom |                          |
|        |             |                |                          |
| 35100C | 100'        | 4 Section Boom | 31' - 55' 2- Section Jib |
|        |             |                |                          |
| 35124C | 124'        | 5 Section Boom | 31' 1- Section Jib       |
|        |             |                |                          |

**UPTime is the Manitex commitment to complete support of thousands of units working every day.**

## ***UPTime***

- Includes 24-7-365 parts shipments.
- Utilizes the efficiency of UPNet online parts order system.
- Relies on Manitex's UPTrak support tracking system for performance analysis and resource allocation.
- Features REMan, Manitex's cost effective rebuild/exchange program.
- Provides expert service technicians for troubleshooting and site visits.
- Mandates training; at our facility and yours. It includes coordinated support from all component suppliers.
- Involves every Manitex team member in the support of every Manitex customer.

### **What does UPTime mean to Manitex customers?**

***UPTime*** means reliability.

***UPTime*** means utilization.

***UPTime*** means profitability.



Manitex  
3000 South Austin Avenue  
P.O. Box 1609  
Georgetown, TX, USA 78627-1609  
Telephone 512-942-3000  
Facsimile 512-863-3776  
[www.manitex.com](http://www.manitex.com)

MTX 3500 • 09.03 • TG • 2,000