

**B1**

STABILIZZATORE REGOLABILE  
CON BLOCCO DI APPOGGIO  
regolable stabilizator  
with concrete pad

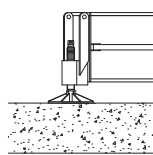

**B2**

STABILIZZATORE REGOLABILE  
regolable stabilizator

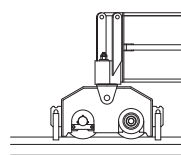

**B3**

TRASLAZIONE MOTORIZZATA  
motorized translation

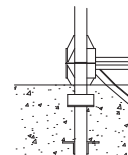







**T4**

TRONCHETTO DI FONDAZIONE  
expendable foundation element



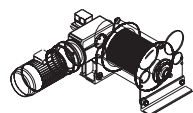

## MECCANISMI MECHANISMS ANTRIEBE MÉCANISMES MECANISMOS

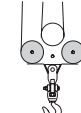
	giri/min	m/min	Nm	Kw
	0,67	-	50	-
	-	8/24/48	-	3
	-	16	-	2x2,2





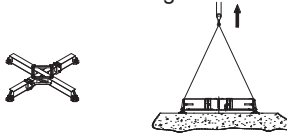
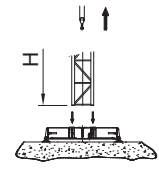
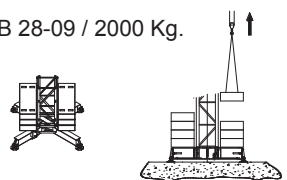
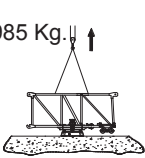
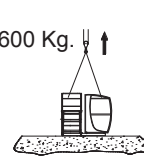
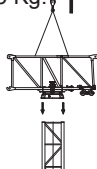
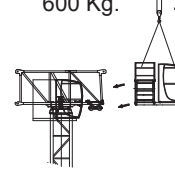
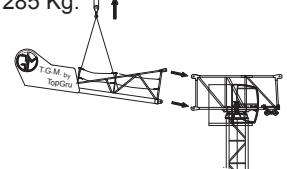
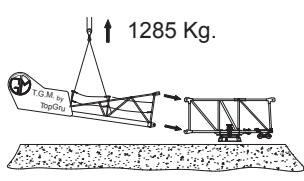
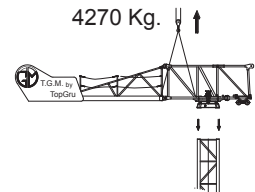
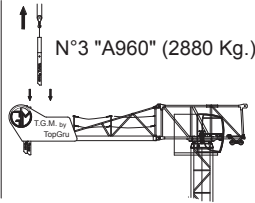

								
	CV - ch PS - hp	KW				m	marcia - step vitesse - gang velocidades	m/min
11 FV3 25 3 velocità 3 speed	15	11	160	1 2 3	5 20 40	2,5 2,5 1,25	2,5 10 20	5,0 5,0 2,5

Potenza totale richiesta - Total installed power Geforderte Stromstärke - Puissance totale nécessaire Potencia necesaria	11 FV3 25 - 27 kVA	400 V - 50 Hz
--	--------------------	---------------

## MONTAGGIO ASSEMBLY VERSAMMEWNG MONTAGE ASAMBLEA

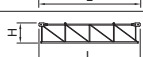
<p>B 3.2x3.2m Tot. 2465 Kg.</p> 		<p>H=11.8 / 2540 Kg. H=5.9 / 1320 Kg. H=2.36 / 575 Kg.</p> 		<p>B 28-09 / 2000 Kg.</p> 	
<p>2985 Kg.</p> 	<p>600 Kg.</p> 	<p>2985 Kg.</p> 	<p>600 Kg.</p> 	<p>1285 Kg.</p> 	
<p>1285 Kg.</p> 		<p>4270 Kg.</p> 	<p>N°3 "A960" (2880 Kg.)</p> 		<p>3423 Kg. (46 m.)</p> 

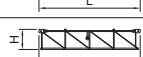
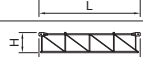
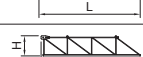
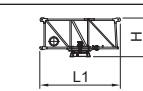
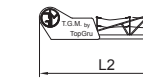
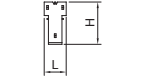
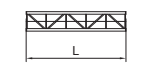
## LISTA DEI PESI PACKING LIST KOLLI-LISTE LISTE DE COLLISAGE LISTA DE PESOS

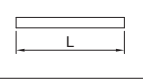
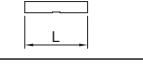
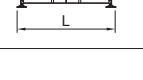
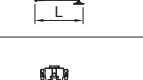
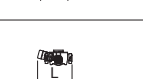
Pos. Item	Pezzi Pieces	Denominazione Description	Schizzo Sketch	Dimensioni Dimensions			Peso Weight (Kg)		
				L	W	H	Unit.	Total.	
1	1	<b>Elemento di freccia</b> Jib element Ausleger Elément de flèche Elemento de flecha	N°9 	4.580	0.790	1.830	*	795	
	1		N°8 	6.050	0.790	1.830	*	526	
	1		N°7 	6.020	0.790	1.840	*	520	
	1		N°2 	5.985	0.790	1.190	*	433	
	1		N°3 	5.985	0.790	1.190	*	321	
	1		N°4 	5.985	0.790	1.190	*	297	
	1		N°5 	5.985	0.790	1.190	*	263	
	1		N°6 	5.860	0.790	1.190	*	238	
2	1	<b>Gruppo Controfreccia girevole</b> Group Counterjib-turntable Groupe Gegenausleger Groupe Contreflèche tournante Contreflecha giratorio		4.76	1.2	2.285	*	2770	
3	1	<b>Elemento controfreccia esterno</b> External counterjib Externes Gegenausleger Contreflèche extérieure Elemento de controflecha externo		7.23	1.07	1.9	*	1285	
4	10	<b>Blocchi di contrappeso</b> Counterweight block Gegengewichtsböcke Contre-poids Bloques de contrapeso		A 960	1.30	0.185	960	9600	
5	1	<b>Elemento di torre</b> Tower element Turmstück Elément de mature Elemento de torre		11.8	1.15	1.15	*	2540	
	1			5.9	1.15	1.15	*	1320	
	1			2.36	1.15	1.15	*	575	
6	1	<b>Tronchetto di fondazione</b> Expendable foundation element Fundamentanker Elément a sceller Tronco de fundacion		1.39	1.37	1.37	*	580	
7	28	<b>Blocco di zavorra</b> Base ballast block Grundballastblöcken Lest de base Bloque de lastre		3,2x3,2m	2.800	0.900	0.360	2000	56000
	-			-	-	-	-	-	-
8	4	<b>Blocco di appoggio</b> Concrete pad Betonfuss Sabot en béton Bloque de apoyo		3.000	0.600	0.600	2465	9860	
9	1	<b>Trave principale di base</b> Base main beam Hauptträger für Kreuzgelenk Poutre de chassis de base Viga principal de la base		3,2x3,2m	5.06	0.67	0.73	-	1235
				-	-	-	-	-	-
10	1	<b>Semi-trave di base</b> Half base beam Hauptträger für Kreuzgelenk Semipoutre de chassis de base Mediaviga de la base		3,2x3,2m	2.45	0.54	0.78	615	1230
11	2	<b>Bilancino di traslazione folle / motorizzato</b> Driven boige Fahrschemel ohne/mit motorantrieb Boggie fou/motorisee Eslinga de viajes motorizados/loco		0.805	0.28	0.450	275	550	
				1.06	0.59	0.450	375	750	
12	2		