



GROVE®
worldwide

**LOADCHARTS
AT425**

**85% STABILITY
ON OUTRIGGERS
75% STABILITY
ON RUBBER**

82643

SERIAL NUMBER

NOTES FOR LIFTING CAPACITIES

GENERAL:

1. Rated loads as shown on lift chart pertain to this machine as originally manufactured and equipped. Modifications to the machine or use of optional equipment other than that specified can result in a reduction of capacity.
2. Construction equipment can be hazardous if improperly operated or maintained. Operation and maintenance of this machine shall be in compliance with the information in the Operator's and Safety Handbook, Service Manual, and Parts Manual supplied with this machine. If these manuals are missing, order replacements from the manufacturer through the distributor.
3. The operator and other personnel associated with machine shall fully acquaint themselves with the latest American National Standards Institute (ANSI) Safety Standards for cranes.

SETUP:

1. The machine shall be leveled on a firm supporting surface. Depending on the nature of the supporting surface, it may be necessary to have structural supports under the outrigger floats or tires to spread the load to a larger bearing surface.
2. For outrigger operation, outriggers shall be properly extended with tires raised free of crane weight before operating the boom or lifting loads.
3. If machine is equipped with front jack cylinder, the front jack cylinder shall be set in accordance with written procedure.
4. When equipped with extendable counterweight, the counterweight shall be fully extended before operation.
5. Tires shall be inflated to the recommended pressure before lifting on rubber.
6. With certain boom and hoist tackle combinations, maximum capacities may not be obtainable with standard cable lengths.
7. Do not travel with crane boom extension or jib erected.

OPERATION:

1. Rated loads at rated radius shall not be exceeded. Do not tip the machine to determine allowable loads. For clamshell or concrete bucket operation, weight of bucket and load must not exceed 80% of rated lifting capacities.
2. All rated loads have been tested to and meet minimum requirements of SAE J1063 OCT80 - Cantilevered Boom Crane Structures - Method of Test, and do not exceed 85% of the tipping load on outriggers as determined by SAE J765 OCT80 Crane Stability Test Code.
3. Rated loads include the weight of hookblock, slings and auxiliary lifting devices and their weights shall be subtracted from the listed rating to obtain the net load to be lifted. When more than the minimum required hoist reeving is used, the additional rope weight shall be considered part of the load to be handled.
4. Load ratings are based on freely suspended loads. No attempt shall be made to move a load horizontally on the ground in any direction.
5. Rated loads do not account for wind on lifted load or boom. It is recommended when wind velocity is above 20 m.p.h. (32km/h), rated loads and boom lengths shall be appropriately reduced.
6. Rated loads are for lift crane service only.
7. Do not operate at a radius or boom length where capacities are not listed. At these positions, the machine may overturn without any load on the hook.
8. The maximum load which can be telescoped is not definable because of variations in loadings and crane maintenance, but it is safe to attempt retraction and extension within the limits of the capacity chart.
9. When either boom length or radius or both are between values listed, the smallest load shown at either the next larger radius or next longer or shorter boom length shall be used.
10. For safe operation, the user shall make due allowances for his particular job conditions, such as: soft or uneven ground, out of level conditions, high winds, side loads, pendulum action, jerking or sudden stopping of loads, hazardous conditions, experience of personnel, two machine lifts, traveling with loads, electric wires, etc. Side pull on boom or jib is extremely dangerous.
11. If machine is equipped with individually controlled powered boom sections, the boom sections must be extended equally at all times.
12. Never handle personnel with this machine without written approval from Grove North America.
13. Keep load handling devices a minimum of 18 inches (45.7 cm) below boom head at all times.
14. The boom angle before loading should be greater than the loaded boom angle to account for deflection.
15. Capacities appearing above the bold line are based on structural strength and tipping should not be relied upon as a capacity limitation.
16. Capacities for the 27 ft. (8.3 m) boom length shall be lifted with boom fully retracted. If boom is not fully retracted, capacities shall not exceed those shown for the 40 ft. (12.2 m) boom length.
17. For boom lengths less than 95 ft. (29.0 m) with the 25 ft. (7.6 m) boom extension erected, the rated loads are determined by boom angle in the column headed by 95 ft. (29.0 m). For boom angles not shown, use rating of next lower boom angle. For this load column, the 25 ft. (7.6 m) boom extension operational mode is to be selected on the LMI.

DEFINITIONS:

1. Operating Radius: Horizontal distance from a projection of the axis of rotation to the supporting surface before loading to the center of the vertical hoist line or tackle with load applied.
2. Loaded Boom Angle (Shown in Parentheses on Main Boom Capacity Chart): is the angle between the boom base section and the horizontal, after lifting the rated load at the rated radius with the rated boom length.
3. Working Area: Areas measured in a circular arc about the center line of rotation as shown on the working area diagram.
4. Freely Suspended Load: Load hanging free with no direct external force applied except by the lift cable.
5. Side Load: Horizontal force applied to the lifted load either on the ground or in the air.

RATED LIFTING CAPACITIES IN POUNDS
27 FT. - 70 FT. BOOM
ON OUTRIGGERS FULLY EXTENDED - 360°

Radius in Feet	#0001 or #01					#0003 or #03
	Main Boom Length in Feet					25 ft. Ext. to 0 ft.
	27	40	50	60	70	95
6	50,000 (68.5)					
8	44,000 (64)	43,650 (73)	42,450 (76.5)			See Note 17
9	41,000 (61.5)	41,000 (71.5)	39,850 (75.5)			
10	40,000 (59)	38,000 (70)	37,550 (74)			
12	31,450 (54)	31,450 (66.5)	31,450 (71.5)	31,450 (75.5)		
15	24,300 (45)	24,300 (61.5)	24,300 (68)	24,300 (72)	22,700 (76.5)	
20	18,000 (23)	17,650 (52.5)	17,650 (61.5)	17,650 (67)	17,650 (72)	12,500 (78)
25		13,300 (42)	13,300 (54.5)	13,300 (61.5)	13,300 (67)	10,750 (74.5)
30	See Note 16	10,400 (28.5)	10,400 (41.5)	10,400 (55.5)	10,400 (62.5)	9,810 (71)
35			8,580 (37.5)	8,580 (49.5)	8,580 (57.5)	8,930 (67.5)
40			7,000 (25)	7,000 (42.5)	7,000 (52)	8,090 (64)
45				5,840 (34)	5,840 (46)	6,720 (60.5)
50				4,800 (23.5)	4,800 (39.5)	5,490 (57)
55					3,900 (31.5)	4,520 (52.5)
60					3,200 (21.5)	3,740 (48.5)
65						3,100 (44)
70						2,560 (39)
75						2,090 (33.5)
80						1,700 (27)
85						1,350 (18.5)
Minimum boom angle (deg.) for indicated length (no load)					0	0
Maximum boom length (ft.) at 0 deg. boom angle (no load)					70	95

Note: () Boom angles are in degrees.

829-008798

#LMI operating code. Two or four digit code depends on LMI system. Refer to LMI manual for instructions.

ON RUBBER CAPACITIES WITH 7.5R 5 XLB** OR XHC** MICHELIN TIRES

STATIONARY CAPACITIES - 360°

Radius in Feet	#9005 or #05				
	Main Boom Length in Feet				
	27	40	50	60	70
8	22,350 (64)				
9	18,050 (61.5)				
10	15,050 (59)				
12	11,100 (54)	10,000 (66.5)			
15	7,720 (45)	7,500 (68)	7,500 (72)	7,500 (72)	
20	4,760 (23)	4,760 (52.5)	4,760 (61.5)	4,760 (67)	4,760 (72)
25		3,130 (42)	3,130 (54.5)	3,130 (61.5)	3,130 (67)
30		2,110 (28.5)	2,110 (46.5)	2,110 (55)	2,110 (62.5)
35			1,410 (37.5)	1,410 (49.5)	1,410 (57.5)
40			900 (25)	900 (42.5)	900 (52)

STATIONARY CAPACITIES - DEFINED ARC OVER REAR (SEE NOTE 3)

Radius in Feet	#9005 or #05				
	Main Boom Length in Feet				
	27	40	50	60	70
8	27,550 (64)				
9	25,000 (61.5)				
10	23,050 (59)				
12	18,550 (54)	16,000 (66)			
15	12,700 (45)	12,700 (61.5)	12,700 (68)	11,000 (72)	
20	7,650 (23)	7,650 (52.5)	7,650 (61.5)	7,650 (67)	7,650 (72)
25		5,250 (42)	5,250 (54.5)	5,250 (61.5)	5,250 (67)
30		3,820 (28)	3,820 (46.5)	3,820 (55.5)	3,820 (62.5)
35			2,850 (37.5)	2,850 (49.5)	2,850 (57.5)
40			2,140 (25)	2,140 (42.5)	2,140 (52)
45				1,600 (34)	1,600 (46)
50				1,180 (23.5)	1,180 (39.5)

A6-829-009105C & -009104C

ON RUBBER CAPACITIES WITH 17.5R25 TIRES (cont'd.)

**PICK & CARRY CAPACITIES - UP TO 2.5 MPH
BOOM CENTERED OVER REAR (SEE NOTE 7)**

Radius in Feet	#9006 or #06			
	Main Boom Length in Feet			
	27	40	50	60
8	24,550 (64)			
9	22,650 (61.5)			
10	20,950 (59)			
12	18,150 (54)	18,150 (66.5)		
15	12,700 (45)	12,700 (61.5)	12,700 (68)	
20	7,650 (23)	7,650 (52.5)	7,650 (61.5)	7,650 (67)
25		5,250 (42)	5,250 (54.5)	5,250 (61.5)
30		3,820 (28.5)	3,820 (46.5)	3,820 (55.5)
35			2,850 (37.5)	2,850 (49.5)
40			2,140 (25)	2,140 (42.5)
45				1,600 (34)
50				1,180 (23.5)

Note: () Boom angles are in degrees.

A6-829-009106C

#LMI operating code. Two or four digit code depends on LMI system. Refer to LMI manual for instructions.

1. Capacities are in pounds and do not exceed 75% of tipping loads as determined by test in accordance with SAE J765 OCT80.
2. Capacities are applicable to machines equipped with 17.5R25 XLB** or 17.5R25 XHC** radial tires, at 102 psi cold inflation pressure.
3. Defined Arc - Over rear includes 6° on either side of longitudinal centerline of machine.
4. Capacities appearing above the bold line are based on structural strength and tipping should not be relied upon as a capacity limitation.
5. Capacities are applicable only with machine on firm level surface.
6. On rubber lifting with boom extensions not permitted.
7. For pick and carry operation, boom must be centered over rear of machine, mechanical swing lock engaged and load restrained from swinging. When handling loads in the structural range with capacities close to maximum ratings, travel should be reduced to creep speeds.
8. Axle lockouts must be functioning when lifting on rubber.
9. All lifting depends on proper tire inflation, capacity and condition. Capacities must be reduced for lower tire inflation pressures. See lifting capacity chart for tire used. Damaged tires are hazardous to safe operation of crane.
10. Creep - not over 200 ft. of movement in any 30 minute period and not exceeding .1 mph.

	No Load Stability Data	Main Boom 70 ft.
Rear (No Load)	Min. boom angle (deg.) for indicated length	24
	Max. boom length (ft.) at 0 deg. boom angle	60
360 Deg. (No Load)	Min. boom angle (deg.) for indicated length	43
	Max. boom length (ft.) at 0 deg. boom angle	50

25 FT. - 43 FT. TELE EXTENSION ON OUTRIGGERS FULLY EXTENDED - 360°

Radius in Feet	25 ft. LENGTH			34 ft. LENGTH			43 ft. LENGTH		
	#0021 or #21	#0022 or #22	#0023 or #23	#0031 or #31	#0032 or #32	#0033 or #33	#0041 or #41	#0042 or #42	#0043 or #43
	0° OFFSET	15° OFFSET	30° OFFSET	0° OFFSET	15° OFFSET	30° OFFSET	0° OFFSET	15° OFFSET	30° OFFSET
20	*12,500 (78.0)			*8,500 (78.0)			*5,000 (78.0)		
25	10,750 (75.0)	7,500 (78.0)		8,030 (77.0)			4,750 (77.5)		
30	9,810 (71.5)	6,870 (74.5)	*5,500 (78.0)	7,170 (74.0)	*5,500 (78.0)		4,360 (75.0)		
35	8,930 (68.0)	6,330 (71.0)	5,110 (74.5)	6,390 (71.0)	4,910 (75.5)	*3,600 (78.0)	4,020 (72.0)	3,000 (78.0)	
40	7,860 (64.5)	5,860 (67.5)	4,770 (71.0)	5,680 (68.0)	4,540 (72.5)	3,290 (76.0)	3,710 (69.5)	2,800 (75.5)	*2,300 (78.0)
45	6,220 (61.0)	5,450 (64.0)	4,490 (67.5)	5,040 (65.0)	4,180 (69.0)	2,930 (72.5)	3,420 (66.5)	2,650 (72.5)	2,210 (76.5)
50	4,960 (57.0)	4,960 (60.0)	4,260 (63.5)	4,590 (61.5)	3,840 (66.0)	2,650 (69.5)	3,170 (64.0)	2,510 (70)	2,160 (73.5)
55	3,970 (53.0)	3,970 (56.0)	3,970 (59.5)	4,200 (58.5)	3,510 (62.5)	2,430 (66.0)	2,940 (61.0)	2,400 (67.0)	2,100 (70.5)
60	3,170 (49.0)	3,170 (52.0)	3,170 (55.5)	3,520 (55.0)	3,200 (59.0)	2,250 (62.0)	2,730 (58.0)	2,300 (64.0)	2,030 (67.0)
65	2,510 (44.0)	2,510 (47.0)	2,510 (50.5)	2,910 (51.0)	2,900 (55.5)	2,100 (58.5)	2,540 (54.5)	2,210 (60.5)	1,970 (63.5)
70	1,960 (39.5)	1,960 (42.5)	1,960 (45.5)	2,390 (47.5)	2,390 (51.5)	1,970 (54.0)	2,360 (51.5)	2,130 (57.5)	1,890 (60.0)
75	1,480 (33.5)	1,480 (36.5)	1,480 (40)	1,960 (43)	1,960 (47)	1,850 (49.5)	2,140 (48.0)	2,060 (54.0)	1,820 (56.5)
80	1,080 (27)	1,080 (30)	1,080 (32.5)	1,580 (38.5)	1,580 (42.5)	1,580 (44.5)	2,010 (44.0)	2,000 (50.0)	1,730 (52.0)
85				1,250 (33)	1,250 (37)	1,250 (39)	1,670 (40)	1,670 (46)	1,640 (48)
90							1,370 (35.5)	1,370 (41.5)	1,370 (42.5)
95							1,100 (30.5)	1,100 (36.5)	

NOTE: () Boom angles are in degrees.

A6-829-008810

*This capacity is based upon maximum boom angle.

#LMI operating code. Two or four digit code depends on LMI system. Refer to LMI manual for instructions.

1. All capacities above the bold line are based on structural strength of boom extension.
2. 25 ft., 34 ft., and 43 ft. boom extension lengths may be used for double or single line lifting service.
3. Radii listed are for a fully extended boom with the boom extension erected. For main boom lengths less than fully extended, the rated loads are determined by boom angle. Use only the column which corresponds to the boom extension length and offset for which the machine is configured. For boom angles not show, use the rating of the next lower boom angle.
4. WARNING: Operation of this machine with heavier loads than the capacities listed is strictly prohibited. Machine tipping with boom extension occurs rapidly and without advance warning.
5. Boom angle is the angle above or below horizontal of the longitudinal axis of the boom base section after lifting rated load.
6. Capacities listed are with outriggers fully extended and vertical jacks set only.
7. 43 FT. BOOM EXTENSION WARNING: For main boom length greater than 60 ft. with 43 ft. tele. boom extension in working position, the boom angle must not be less than 30° since loss of stability will occur causing a tipping condition. The boom angle is not restricted for main boom length equal to or less than 60 ft. This warning also applies for boom extension erection purposes.
8. NO LOAD STABILITY WITH 25 FT. AND 34 FT. BOOM EXTENSION ERECTED: With no load, the length or angle of the main boom is not restricted.

LIFTING ON TRIGGERS
6-829-008031

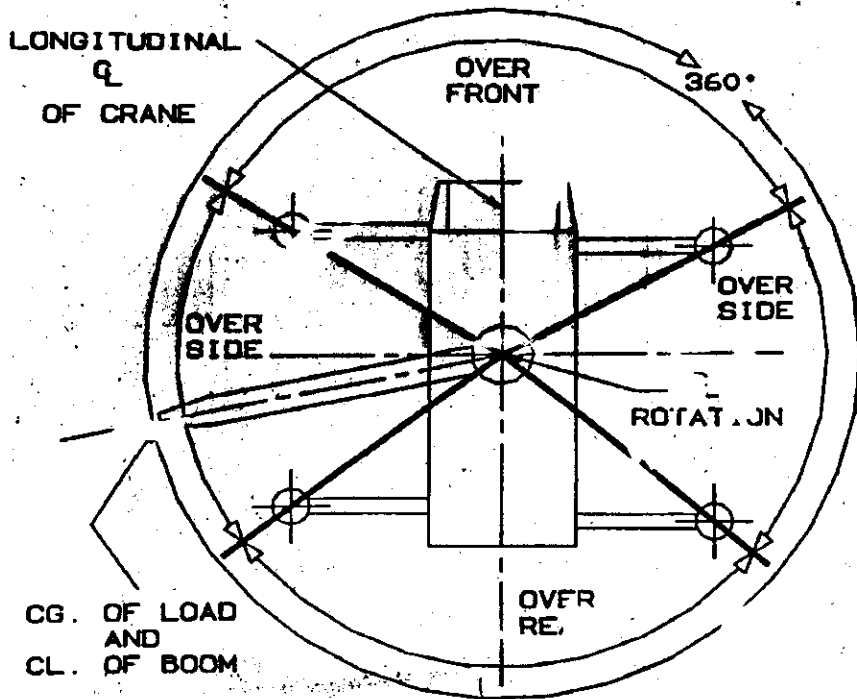

LIFTING ON RUBBER
6-829-008030

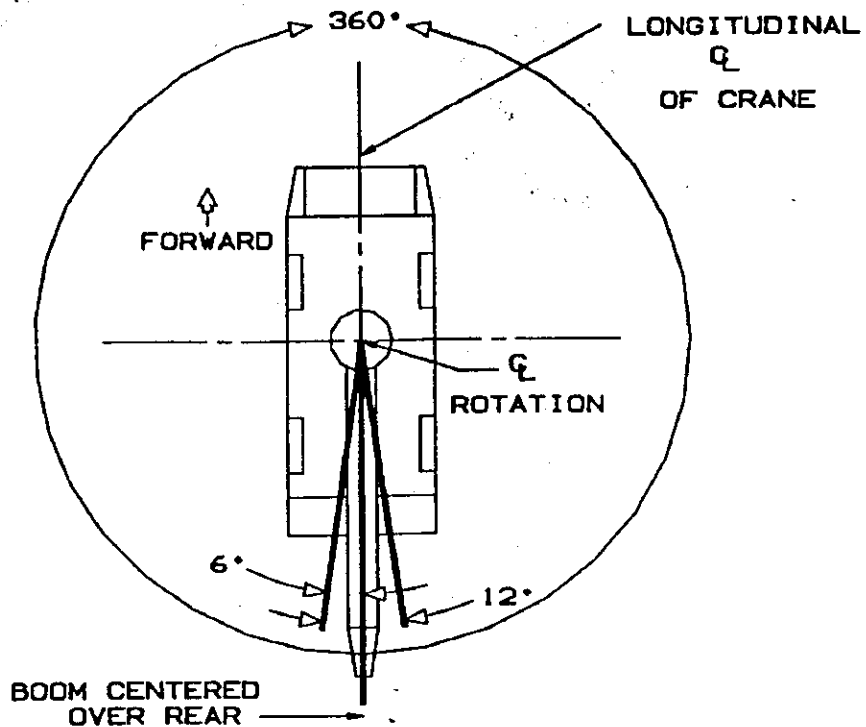

BOLD LINES DETERMINE THE LIMITING POSITION OF ANY
LOAD FOR OPERATION WITHIN WORKING AREAS INDICATED
WORKING AREA DIAGRAM

LINE PULLS AND REEVING INFORMATION

HOISTS	CABLE SPECS.	PERMISSIBLE LINE PULLS
Main & Aux. Model 15	5/8" (16 mm) 18x19 Class or 35x7 Rotation Resistant Min. Breaking Str. 45,400 lbs.	8,074 lbs.
Main & Aux. Model 15	5/8" (16 mm) 6x37 EIPS, IWRC Min. Breaking Str. 41,200 lbs.	8,074 lbs.

WEIGHT REDUCTIONS FOR LOAD HANDLING DEVICES

25 FT. BOOM EXTENSION	
*Stowed -	293 lbs.
*Erected -	1,563 lbs.
25 FT. - 43 FT. TELE. BOOM EXTENSION	
*Stowed -	535 lbs.
*Erected (Retracted) -	3,906 lbs.
*Erected (Extended) -	4,995 lbs.

*Reduction of main boom capacities

AUXILIARY BOOM HEAD	145 lbs.
HOOKBLOCKS and HEADACHE BALLS:	
22 Ton, 3 Sheave	498 lbs.+
15 Ton, 2 Sheave	462 lbs.+
12 Ton, 1 Sheave	360 lbs.+
5 Ton Headache Ball	172 lbs.+

+Refer to rating plate for actual weight.

When lifting over swingaway and/or jib combinations, deduct total weight of all load handling devices reeved over main boom nose directly from swingaway or jib capacity.

NOTE: All load handling devices and boom attachments are considered part of the load and suitable allowances MUST BE MADE for their combined weights. Weights are for Grove furnished equipment.

RANGE DIAGRAM (UNLADEN BOOM) D6-829-008719

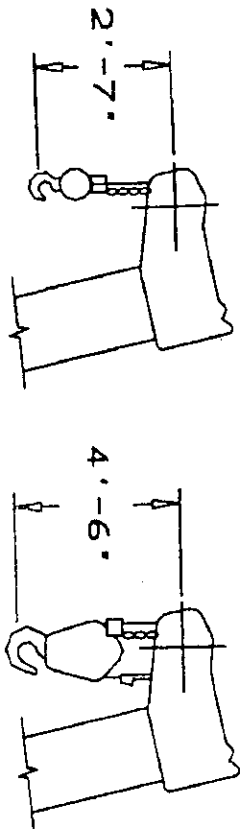
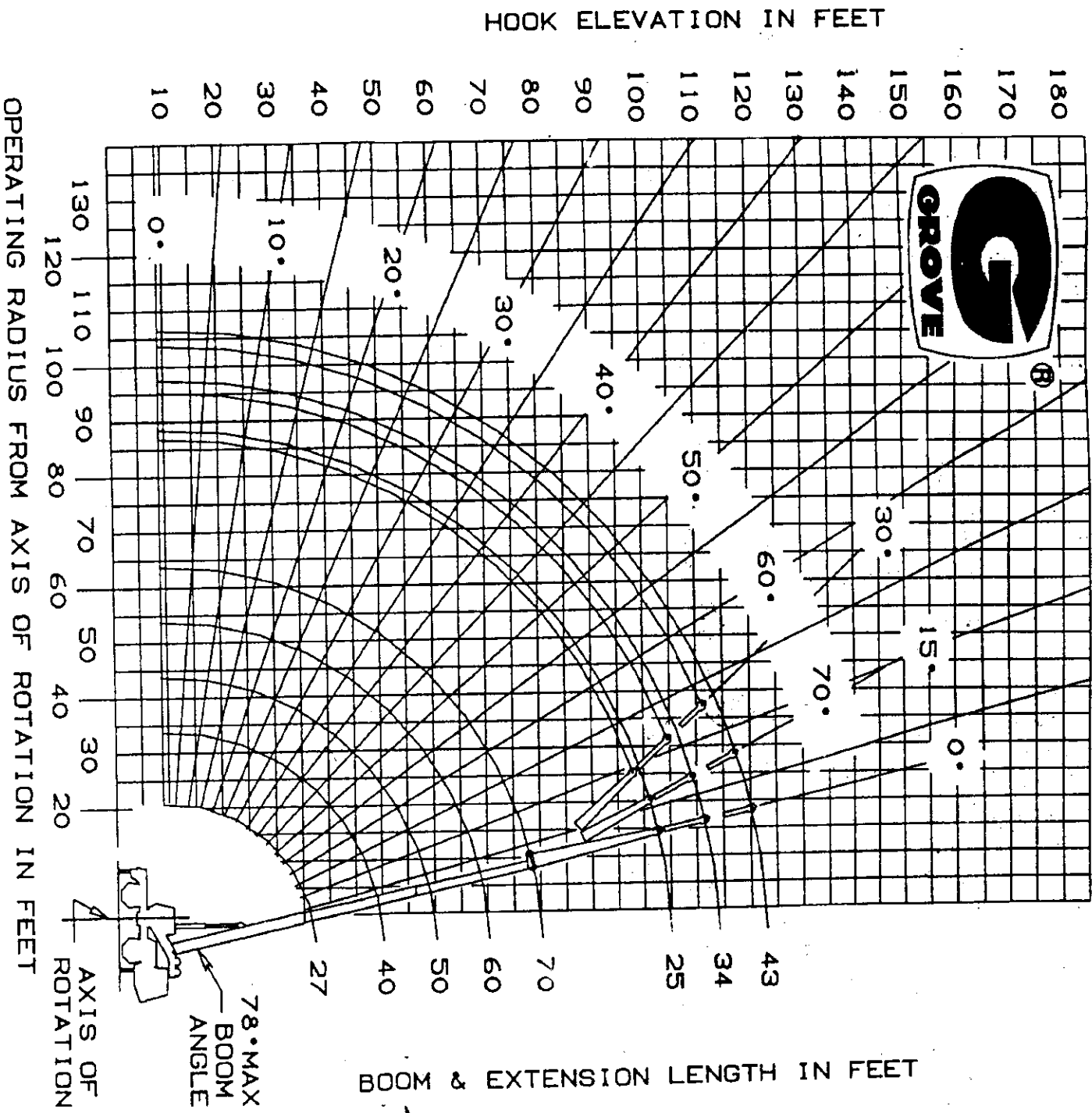

DIMENSIONS ARE FOR LARGEST GROVE FURNISHED HOOK BLOCK AND HEADACHE BALL WITH ANTI-TWO BLOCK ACTIVATED.

ZERO DEGREE BOOM ANGLE CHARTS

ON OUTRIGGERS FULLY EXTENDED - 360°

Boom Angle	Main Boom Length in Feet				
	27	40	50	60	70
0°	13,050 (21.1)	7,920 (33.7)	5,700 (43.7)	4,190 (53.7)	2,930 (63.8)

ON RUBBER 17.5R25 XLB** OR XHC** MICHELIN TIRES

Stationary Capacities Defined Arc Over Rear and
Pick & Carry Capacities Up to 2.5 MPH Boom Centered Over Rear

Boom Angle	Main Boom Length in Feet				
	27	40	50	60	
0°	6,910 (21.1)	3,060 (33.7)	1,720 (43.7)	920 (53.7)	

Stationary Capacity 360° Arc

Boom Angle	Main Boom Length in Feet		
	27	40	50
0°	4,330 (21.1)	1,560 (33.7)	600 (43.7)

A6-829-009104 & -009105 & -009106

Note: () Reference radii in feet.