

# ETC 37 IH

Articulated / Telescopic Insulated



## Insulated versatility

This ETC model is one of the most popular products offered by ETI and with good reason. The ETC 37 IH is an insulated unit that offers an articulating and telescoping aerial with a working height of 42 feet. Its many standard options include boom tip covers, single handle controls, continuous rotation, full pressure hydraulic controls, emergency lowering valve and more. It can be fully customized to a customer's individual need by adding a host of options including increased bucket capacity, tool circuit, outriggers and others. This model is built to satisfy customer demand for power, reach, and innovative design.

**ETI.**  
A PALFINGER Company

Equipment Technology LLC is a full service solution provider of the highest quality design, manufacturing, and post sale service.

Equipment Technology LLC  
 341 NW 122nd  
 Oklahoma City, OK 73114  
 Toll-Free: 1-888-748-3841  
 Fax: 1-405-755-6829  
 www.eti1.com

### ETC 37 IH

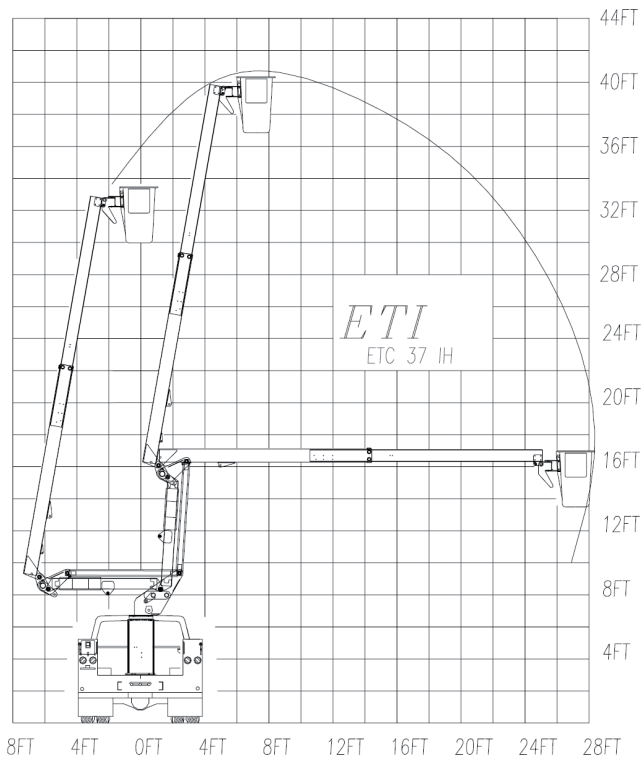

### General Specifications\*

Height to bottom of bucket	37 ft. - 1 in.
Working height	42 ft. - 1 in.
Side reach, End mount	28 ft. - 0 in.
Rotation	Continuous
Lower boom articulation	0° to 93° degrees
Upper boom travel	-17° to 75° degrees
Rated bucket capacity	350 lbs.

### Hydraulic System

Operating pressure (min)	2,250 psi.
Operating volume	5 gpm



### Minimum Vehicle Specifications

- GVWR 16,000 lbs.
- C.A. 60 in

### Options

- Emergency hydraulic power (12VDC)
- Engine start/stop at bucket
- Hydraulic tool circuit
- Two speed throttle
- Bucket liner
- Bucket cover
- Lower boom and compensating link inserts
- Electric tool circuit (non-insulated units)
- Oversized bucket (24" x 30" x 42")
- Splicer bucket (non-insulated units)
- Hydraulic bucket rotator
- Outriggers
- APU - Auxiliary power unit to operate aerial unit & heat/cool cab

### Standard Features

- Boom tip covers.
- Single handle control.
- Continuous rotation is standard on all ETC units providing unrestricted rotation.
- Lower boom compensating link.
- Full pressure hydraulic controls located at basket and turret with full feathering capabilities from both upper and lower controls.
- Hydraulic leveling via master/slave system providing a bucket dump for clean out and operator rescue.
- Shear ball rotation gear driven by external drive gear box. Gear box has an extended shaft for manual rotation.
- Internally mounted holding valve (integral part of cylinder) locks cylinder in place in event of hydraulic failure.
- All pins turn on replaceable bushings.
- Inner boom extends with double acting hydraulic cylinder for safety and performance.
- Emergency lowering valve.