

ATF 400G-6

400 METRISCHE TONNEN TRAGLAST / 400 METRIC TON CAPACITY

**ALL
TERRAIN
CRANE**



Highlights

Highlights des ATF 400G-6:

- Einhaltung der 12 t Achslasten inkl. Antrieb 12 x 8 x 12, Bereifung 445/95 R 25 (16.00 R 25).
- Leistungsstärkstes Antriebspaket seiner Klasse mit sparsamen Mercedes Benz BlueTec Motor, 480 kW Leistung und 3000 Nm Drehmoment sowie einem hochtechnisiertem ZF-TC-Tronic HD Getriebe in "Heavy Duty" Ausführung.
- Separater Oberwagenmotor von Mercedes Benz mit BlueTec Technologie und 195 kW Leistung und 1100 Nm Drehmoment.
- Der 60 m Hauptausleger erreicht die höchsten Traglastwerte seiner Klasse. Zum Vergrößern der Traglasten kann er zusätzlich mit einem "Power System" ausgerüstet werden.
- Vollhydraulisch abwinkelbare und teleskopierbare Auslegerverlängerung (HTLJ) für effizientes Arbeiten und Montage auf engstem Raum (Funktion wie zusätzlicher Teleskopausleger).
- Fahrzeugbreite innerhalb von 3 m bei einem Gegengewicht bis zu 25 t.
- Das Sicherheitsprogramm 'Lift- und Release Adjuster' unterbindet das gefährliche Pendeln der Last, bzw. des Hakens und sorgt somit für höchste Sicherheit und äußerst kontrollierbare Hubbewegungen bei jedem Einsatz.
- Effiziente Serviceplanung sowie Durchführung von Fehlerferndiagnosen/-behebungen mit Unterstützung der Online-Kommunikation zwischen Kranhersteller, Kranbetreiber und Kran (Hello-Net).

Points forts de l' ATF 400G-6:

- 12 t par essieu avec entraînement 12 x 8 x 12, pneus 445/95 R 25 (16.00 R 25).
- La chaîne d'entraînement la plus performante de sa catégorie avec le dernier développement et un moteur Mercedes Benz Blue Tec sophistiqué qui économise le plus la consommation de gazole, puissance 480 kW et 3000 Nm couple ainsi qu'une transmission haute technologie ZF-TC-Tronic HD transmission en version « poids lourds ».
- Moteur Mercedes Benz BlueTec pour la superstructure, puissance 195 kW et 1100 Nm couple.
- La flèche principale de 60 m atteint la plus grande capacité dans sa classe. La flèche principale peut être équipée en supplément avec le « Power System » pour augmenter la capacité de levage.
- Le système de la fléchette avec inclinaison et télescopage hydraulique (HTLJ) est conçu pour les opérations dans des espaces limités. (comme une flèche additionnelle au bout de la flèche télescopique).
- Jusqu'à 25 t de contrepoids la largeur du véhicule n'est pas dépassé.
- Les dispositifs de sécurité 'Lift- et Release Adjuster' évitent le balancement dangereux de la charge et du moufle et garantissent une sécurité supérieure et mouvement de levage qui sont contrôlables sur chaque levage.
- Planning du service efficient ainsi qu'un diagnostic de dysfonctionnement, ajustement et corrections peuvent être opérés par communication en ligne (Hello-Net) entre le fabricant, le client et la grue.

Highlights of the ATF 400G-6:

- 12 t axle load including drive 12 x 8 x 12, tyres 445/95 R 25 (16.00 R 25).
- The most powerful drive system in his class with the latest state of the art fuel saving Mercedes Benz BlueTec engine, 480 kW engine power and 3000 Nm torque as well as a high technology ZF-TC-Tronic HD transmission in "heavy duty" version.
- Separate superstructure engine Mercedes Benz BlueTec engine, 195 kW engine power and 1100 Nm torque.
- The 60 m main boom achieves the highest capacity in his class. The main boom can be additionally equipped with the "Power System" to increase the lifting capacity.
- The Hydraulic Telescopic Luffing Jib (HTLJ) is made to be fitted and operate in narrow areas (like an additional telescopic boom on top of the main telescopic boom).
- With up to 25 t counterweight the vehicle width is not exceeded.
- The safety features 'Lift- and Release Adjuster' avoiding of dangerous swing of the load and the hook block and providing highest safety and controllable lifting motions on each job.
- Efficient Service planning as well as malfunction diagnostic, adjustment and corrections can be made via online-communication (Hello-Net) between the manufacturer, the client and the crane.

Highlights del ATF 400G-6:

- Peso por eje de 12 t incluido, tracción 12 x 8 x 12, neumáticos 445/95 R 25 (16.00 R 25).
- Paquete de potencia con motor Mercedes Benz BlueTec 480 kW y 3000 Nm de par motor. Caja de cambios de alta tecnología modelo ZF-TC en versión "heavy duty".
- Motor independiente de grúa Mercedes Benz Blue Tec de 195 kW y 1100 Nm de par motor.
- Longitud de pluma de 60 m. Con las mejores tablas de carga en su categoría. Mejora de tablas de carga con el montaje adicional del "Power System".
- Plumin adicional con funciones hidráulicas de telescopaje y angulación (HTLJ). Optimización de espacios en zonas reducidas (funciona como pluma adicional tipo JIB).
- Ancho de maquina de 3 m incluido contrapeso de hasta 25 t.
- Programa de seguridad 'Lift- and Release Adjuster', controla los posibles movimientos oscilantes del gancho, asegurado en cada movimiento el máximo control de la carga.
- Planificación eficiente de servicio técnico mediante un servicio de diagnosis de averías Online de comunicación creando una red entre Fabricante – Usuario – Grúa (Hello-Net).

Seite / Page Page / Pagina	Gegengewicht / Counterweight Contrepoids / Contrapeso	Systemübersicht / General survey of the system Vue d'ensemble du système / Sistema de vigilancia	
4-7		Auslegerverlängerungen / Boom extensions / Fléchette / Plumin	1
8-9		Gegengewichtvarianten / Counterweight versions / Variations des contrepoids / Variaciones de contrapeso	
10-11		Maße + Gewichte / Geschwindigkeiten / Dimensions + Weights / Working speeds / Dimensiones + Poids / Vitesses / Dimensiones + Pesos / Velocidades de trabajo	
12-15	98 t / 78 t / 58 t	MB	2
16-18	47 t / 36 t / 25 t / 16.5 t / 7.5 t	Teleskopausleger / Telescopic boom / Flèche télescopique / Pluma telescópica	
19	0 t		
20-21	98 t	MB + LFJ	3
22	58 t	Teleskopausleger / Telescopic boom / Flèche télescopique / Pluma telescópica + Light fixed jib	
24-25	98 t / 58 t Heavy Duty	MB + Heavy Duty	4
		Teleskopausleger / Telescopic boom / Flèche télescopique / Pluma telescópica + Heavy Duty	
26-33	98 t / 58 t	MB + FJ	5
		Teleskopausleger / Telescopic boom / Flèche télescopique / Pluma telescópica + Fixed jib	
34-39	98 t / 58 t	MB + HTLJ	6
		Teleskopausleger / Telescopic boom / Flèche télescopique / Pluma telescópica + Hydraulic telescopic luffing jib	
40		Anmerkungen zu den Traglasttabellen / Remarks relating to the rating charts / Remarques relatives aux tableaux des charges / Notas relativas a los graficos de carga	7
42-45		Ausrüstung / Equipment / Equipement / Equipo	
46		Symbolerklärung / Symbols / Glossaire des symboles / Glosario de simbolos	



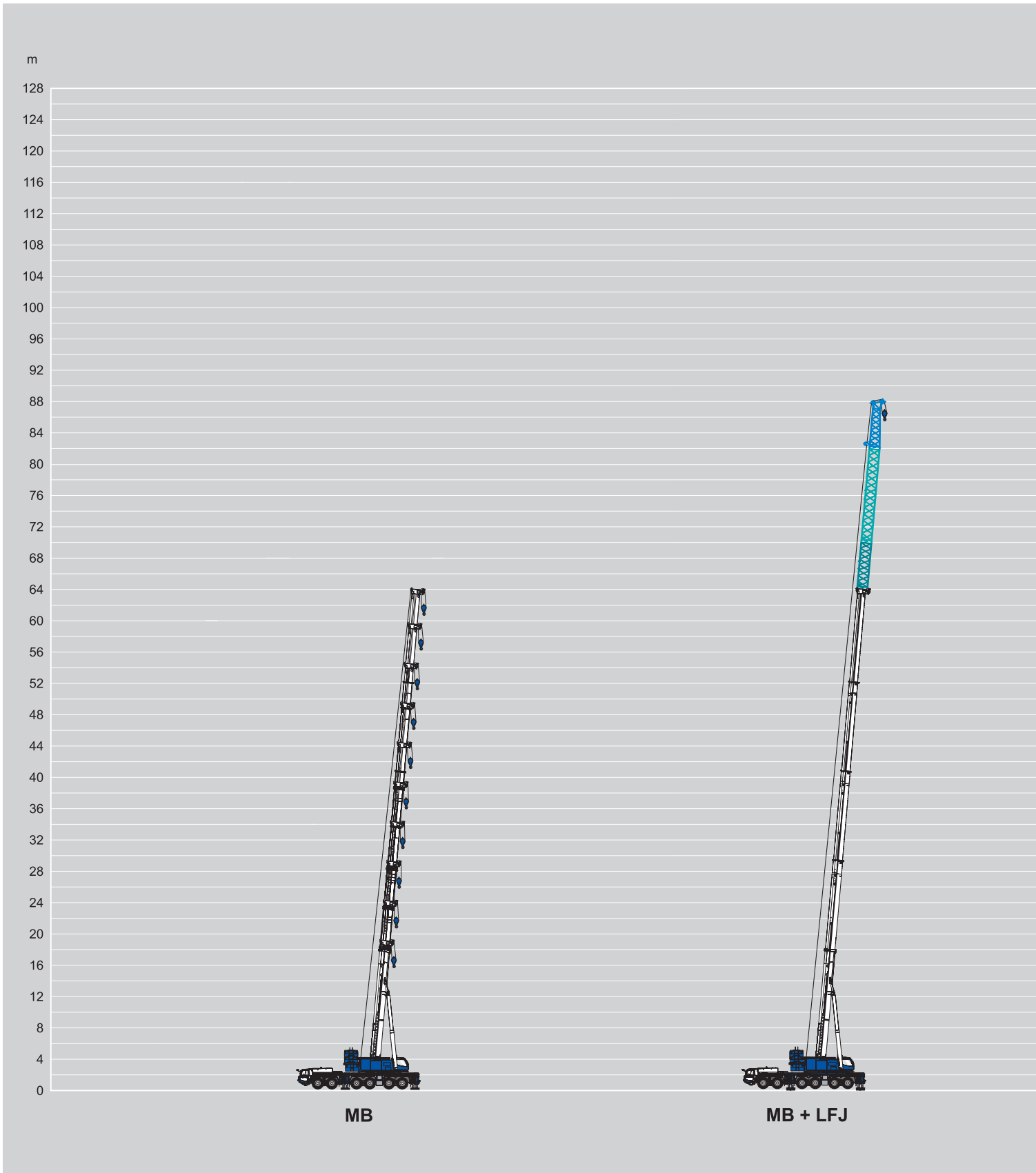

Hubhöhen + Anbauteile
 Lifting heights + Attachment
 Hauteurs de levage + Attachement
 Alturas de elevación + Elemento de construcción

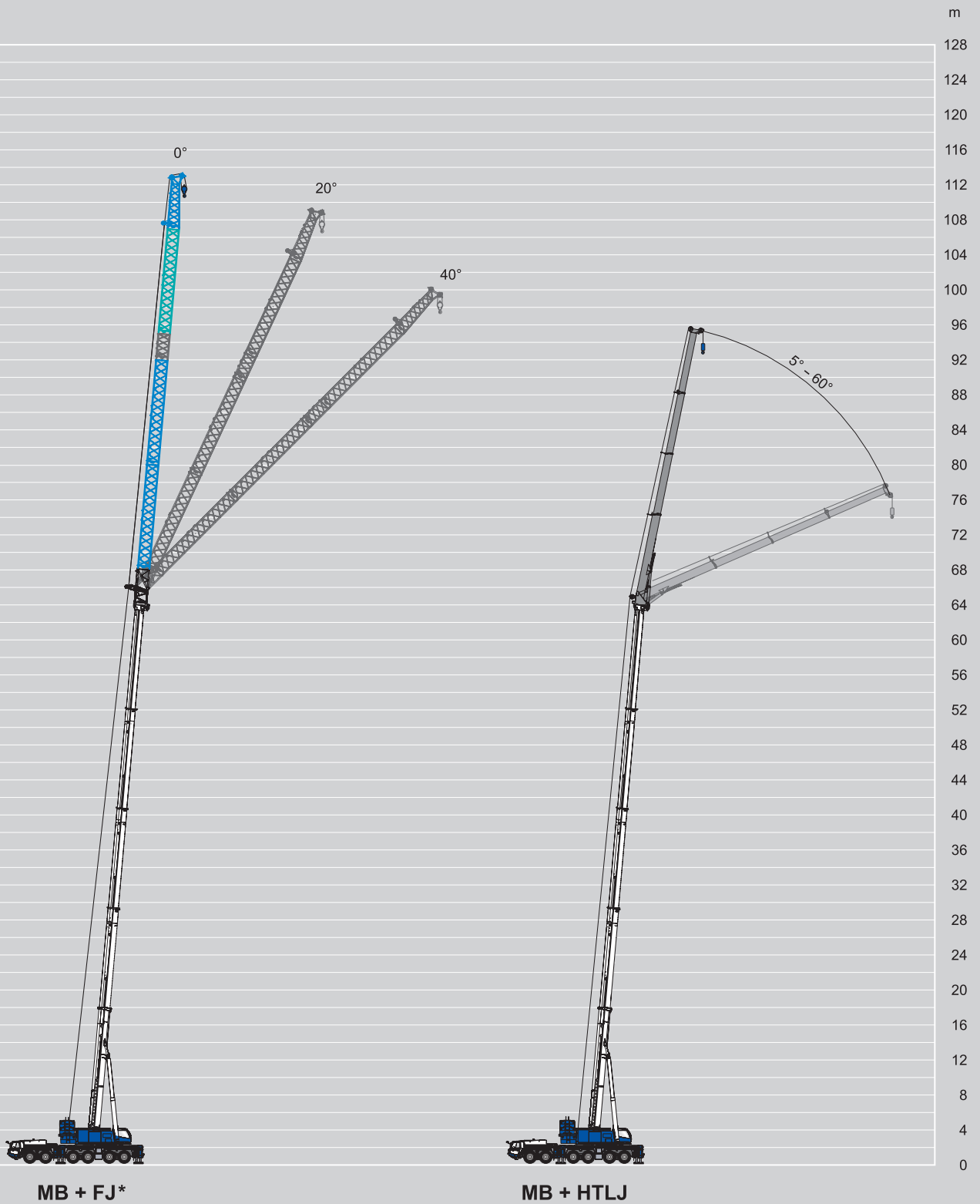









DIN/ISO/EN



Übersicht
 General survey
 Vue d'ensemble
 Sistema de vigilancia

	
6 m	
12 m	
18 m	
24 m	

	
Heavy Duty 2.0 m + 3.5 m (5.5 m)	

	
2.0 m + 11.5 m (13.5 m)	
2.0 m + 17.5 m (19.5 m)	
2.0 m + 23.5 m (25.5 m)	
2.0 m + 29.5 m (31.5 m)	
2.0 m + 35.5 m (37.5 m)	
2.0 m + 41.5 m (43.5 m)	
2.0 m + 47.5 m (49.5 m)	

Übersicht + Teile
 General survey + parts
 Vue d'ensemble + parts
 Sistema de vigilancia + parte

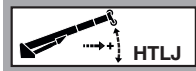

2.3 m + 10.3 m
 (12.6 m)

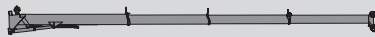

2.3 m + 31 m
 (33.3 m)

Abmessungen + Gewichte / Dimensions + Weights / Dimensiones + Poids / Dimensiones + Pesos

3



Zwischenstück / Intermediate section / Section intermédiaire / Tramo intermedio 12 m

Länge / Length / Longueur / Largo : 12.162 m
 Breite / Width / Large / Ancho : 1.836 m
 Höhe / Height / Hauteur / Altura : 1.520 m
 Gewicht / Weight / Poids / Peso : 2047 kg

4



Reduzierstück / Reducer / Adaptateur / Adaptador conico de "LJ a FJ" 3 m

Länge / Length / Longueur / Largo : 3.162 m
 Breite / Width / Large / Ancho : 1.836 m
 Höhe / Height / Hauteur / Altura : 1.506 m
 Gewicht / Weight / Poids / Peso : 710 kg

6



Zwischenstück / Intermediate section / Section intermédiaire / Tramo intermedio 6 m

Länge / Length / Longueur / Largo : 6.162 m
 Breite / Width / Large / Ancho : 1.081 m
 Höhe / Height / Hauteur / Altura : 1.475 m
 Gewicht / Weight / Poids / Peso : 900 kg

7



Zwischenstück / Intermediate section / Section intermédiaire / Tramo intermedio 12 m

Länge / Length / Longueur / Largo : 12.162 m
 Breite / Width / Large / Ancho : 1.081 m
 Höhe / Height / Hauteur / Altura : 1.475 m
 Gewicht / Weight / Poids / Peso : 1550 kg

8



Auslegerspitze / Jib top section / Flèche / Punta de plumin 6 m

Länge / Length / Longueur / Largo : 6.515 m
 Breite / Width / Large / Ancho : 1.128 m
 Höhe / Height / Hauteur / Altura : 2.021 m
 Gewicht / Weight / Poids / Peso : 1386 kg

9



Abwinkelstück / Adapter fixed jib / Adaptateur de flèche / Adaptador de pluma 4.15 m

Länge / Length / Longueur / Largo : 4.312 m
 Breite / Width / Large / Ancho : 2.045 m
 Höhe / Height / Hauteur / Altura : 2.798 m
 Gewicht / Weight / Poids / Peso : 2164 kg

10



Schwerlastkopf / Heavy duty top section / Tête d'élément pour levage lourd / Cabezal 1 m

Länge / Length / Longueur / Largo : 1.473 m
 Breite / Width / Large / Ancho : 1.747 m
 Höhe / Height / Hauteur / Altura : 2.595 m
 Gewicht / Weight / Poids / Peso : 579 kg



HTLJ

Länge / Length / Longueur / Largo : 12.712 m
 Breite / Width / Large / Ancho : 1.568 m
 Höhe / Height / Hauteur / Altura : 2.362 m
 Gewicht / Weight / Poids / Peso : 10150 kg

Gegengewichtvarianten
 Counterweight versions
 Variations des contrepoids
 Variaciones de contrapeso

Gesamtgewicht Total weight Poids total Peso total	Gegengewicht / Counterweight / Contrepoids / Contrapeso					
	7.5 t ①	9 t ②	8.5 t ③	11 t ④	11 t ⑤	10 t ⑥
98 t	1	1	1	2	1	4
78 t	1	1	1	2	1	2
58 t	1	1	1	2	1	
47 t	1	1	1	2		
36 t	1	1	1		1	
25 t	1	1	1			
16.5 t	1	1				
7.5 t	1					

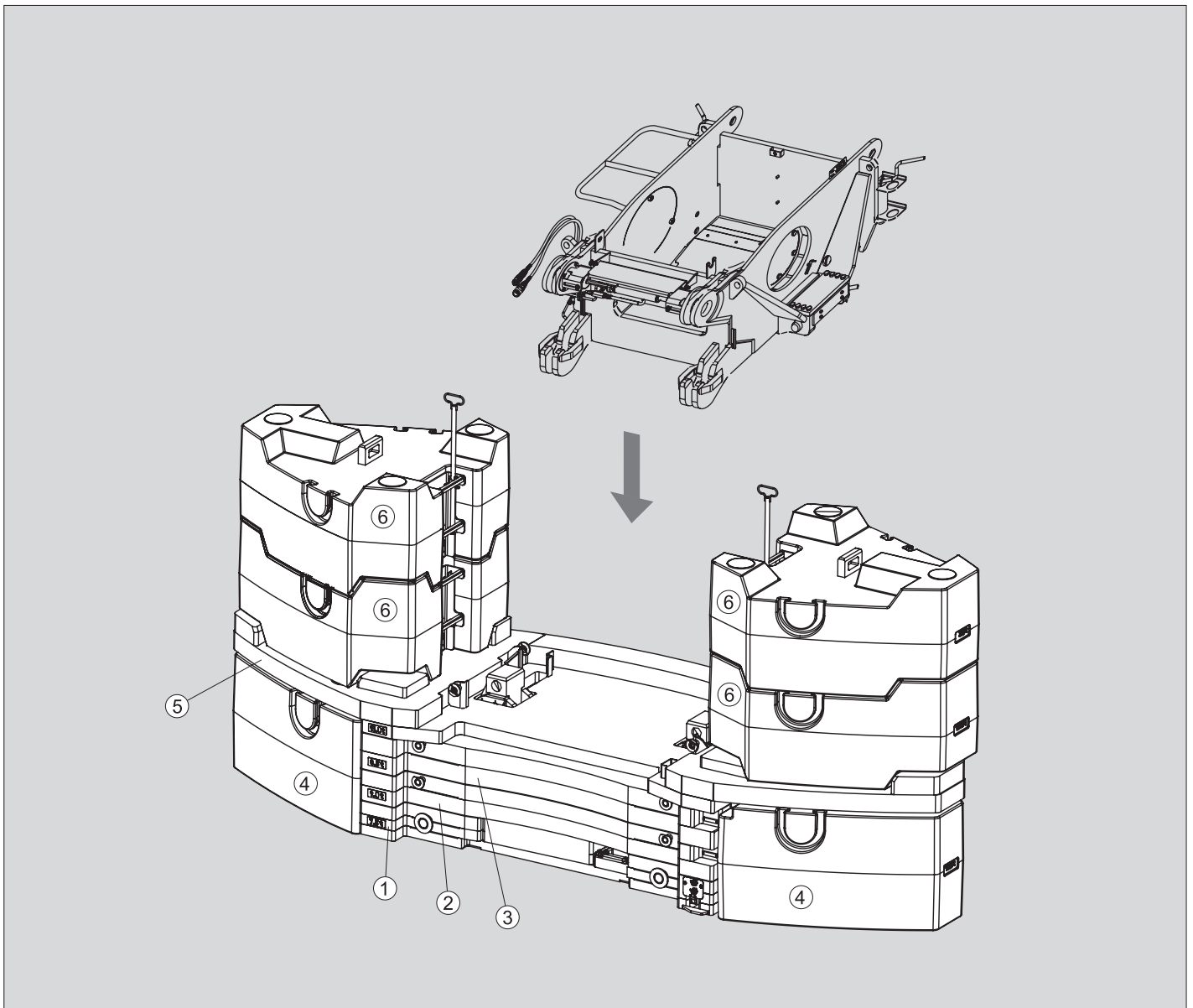
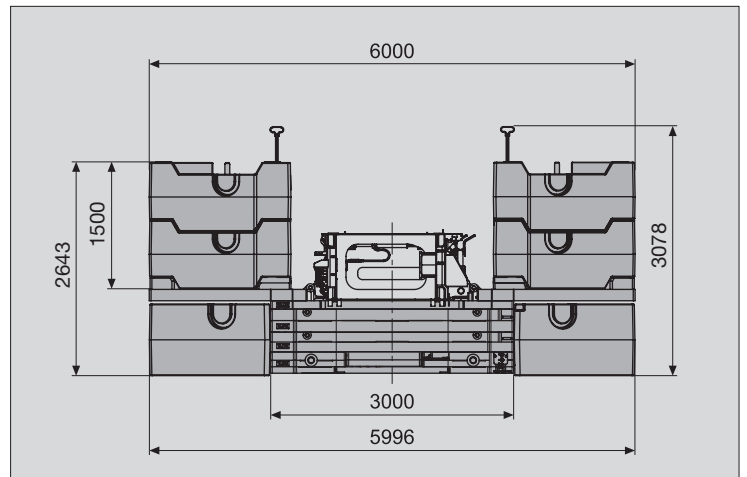

Gegengewichtvarianten
Counterweight versions
Variations des contrepoids
Variaciones de contrapeso

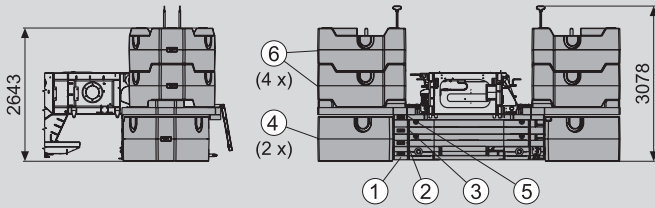
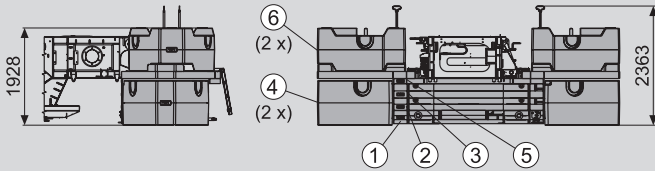
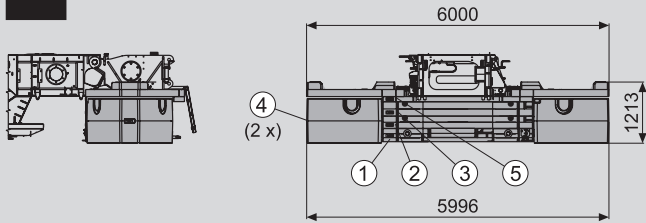
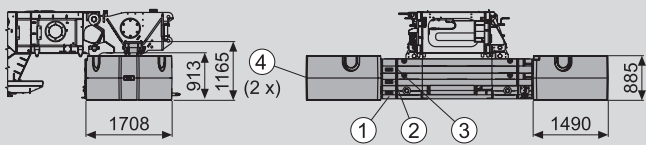
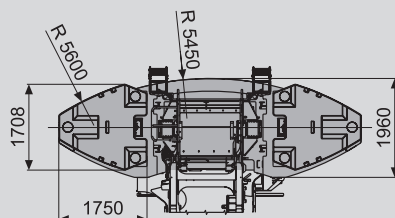
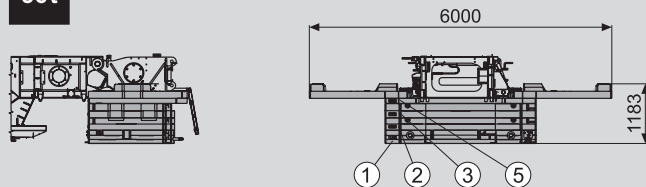
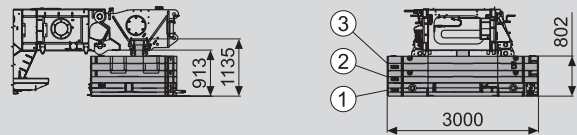
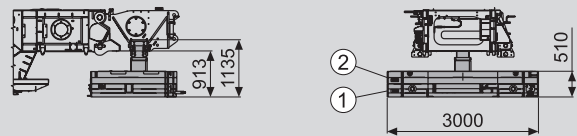
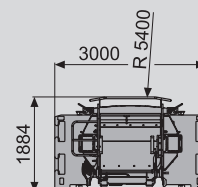
98t

78t

58t

47t

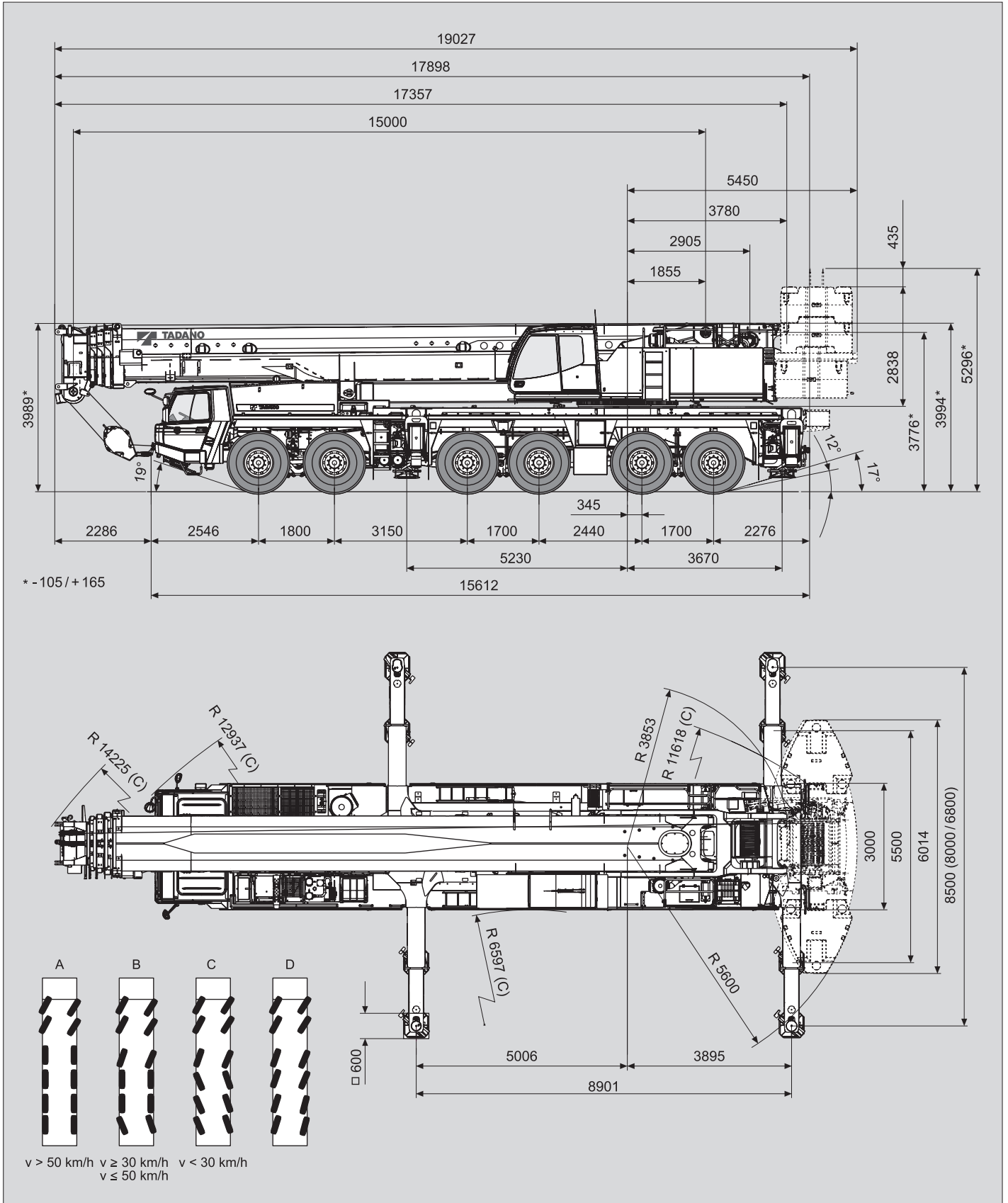
36t

25t

16.5t

7.5t

Maße (mm)
 Dimensions (mm)
 Dimensiones (mm)

445/95 R 25
 (16.00 R 25)

DIN/ISO/EN



Gewichte / Geschwindigkeiten
Weights / Working speeds
Poids / Vitesses
Pesos / Velocidades de trabajo

	Achse / Axle Essieu / Eje	1	2	3	4	5	6	Gesamtgewicht / Total weight Poids total / Peso total
	(t)	12	12	12	12	12	12	12

* Incl. 12,5 t Hakengeschrir, Werkzeugkasten, Antrieb 12 x 8 x 12, Bereifung 445/95 R 25 (16.00 R 25).
 * Incl. 12.5 t swivel hook, toolbox, drive 12 x 8 x 12, tyres 445/95 R 25 (16.00 R 25).
 * Incl. 12,5 t elingues, boîte à outils, entraînement 12 x 8 x 12, pneus 445/95 R 25 (16.00 R 25).
 * Incl. 12,5 t gancho de bola, caja de herramientas, tracción 12 x 8 x 12, neumáticos 445/95 R 25 (16.00 R 25).

	Traglast / Lifting capacity / Force de levage / Capacidad de elevación	Rollen / Sheaves Pulies / Poleas	Stränge / Parts of line Brins / Ramales de cable	Gewicht / Weight Poid / Peso
	221.6 t (Typ / Type / Typo 250)*	9	19	2700 kg
177.1 t (Typ / Type / Typo 200)*	7	15	2300 kg	
131.4 t (Typ / Type / Typo 160)*	5	11	1800 kg	
84.6 t (Typ / Type / Typo 100)*	3	7	1550 kg	
36.7 t (Typ / Type / Typo 40)	1	3	600 kg/950 kg	
12.3 t (Typ / Type / Typo 12.5)	-	1	410 kg	

* Doppelhaken
 * Rams horn
 * Moufle avec crochet marin
 * Gancho doble



	1	2	3	4	5	6	7	8	9	10	11	12	R1	R2	
km/h	3.6	4.6	5.9	7.6	9.6	12.3	16.3	20.9	27.0	34.6	43.9	56.3	3.9	4.9	54.9%
km/h	445/95 R 25 (16.00 R 25)		53.5%*												
	3.9	5.0	6.4	8.3	10.5	13.4	17.7	22.7	29.4	37.7	47.7	61.2	4.2	5.4	49.2%
km/h	6.0	7.7	9.9	12.7	16.1	20.6	27.3	35.0	45.2	58.0	73.5	85.0	6.5	8.3	

* Mit Geländeübersetzung * Avec mode tout terrain
 * Off road range * Con transmisión todo terreno

V+	Stufenlos Infinitely variable Progressivement variable Infinitamente variable	Seil Rope Câble Cable	Seilzug Single line pull Effort au brin simple Trio por ramal
	0 - 125 m/min für einfachen Strang single line au brin simple ramal simple	23 mm / 350 m	120 kN
	0 - 125 m/min für einfachen Strang single line au brin simple ramal simple	23 mm / 580 m	120 kN
	0 - 1.1 min ⁻¹		
	- 0.8° - + 83.5° ca. 50 s approx. 50 s env. 50 s aproximadamente 50 s		
	15.0 m - 60.0 m ca. 500 s approx. 500 s env. 500 s aproximadamente 500 s		

Hubhöhen
Lifting heights
Hauteurs de levage
Alturas de elevación

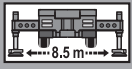
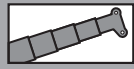

98t

DIN/ISO/EN

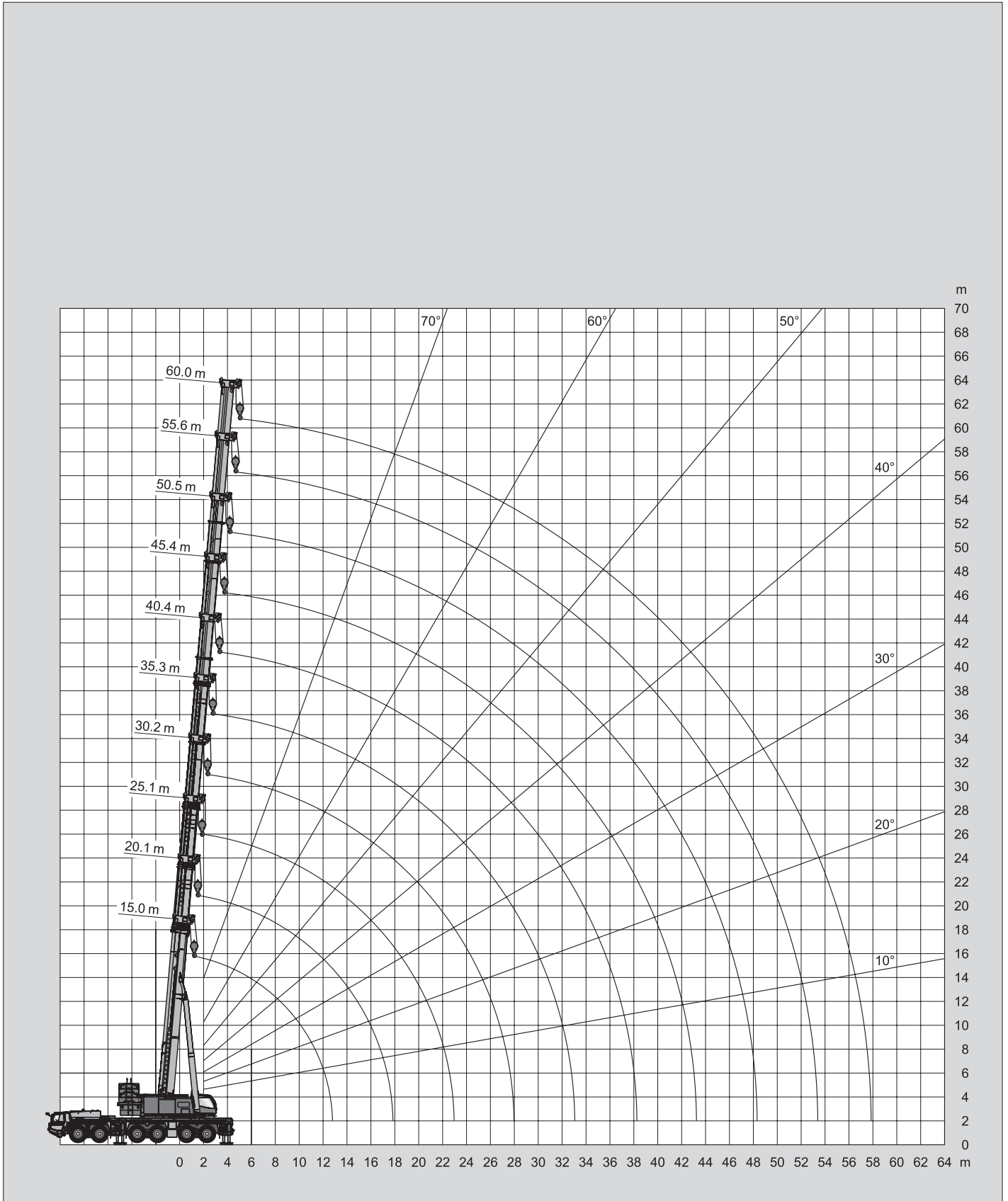

Tragfähigkeiten
Lifting capacities
Capacités de levage
Capacidades de elevación



 m	15.0 m	20.1 m	25.1 m	30.2 m	35.3 m	40.4 m	45.4 m	50.5 m	55.6 m	60.0 m
2.7	400.0*									
3.0	200.0	170.0	162.0							
3.5	200.0	170.0	162.0							
4.0	200.0	170.0	162.0	139.0						
4.5	192.9	170.0	162.0	139.0						
5.0	180.6	170.0	162.0	139.0	123.4					
6.0	158.0	157.6	157.0	139.0	113.8	84.2				
7.0	139.9	139.6	138.9	127.9	103.1	84.2	71.6			
8.0	125.2	124.8	124.1	118.2	94.2	84.2	71.6	54.3		
9.0	112.9	112.5	112.5	109.8	86.7	79.5	69.5	54.3	45.0	
10.0	102.6	102.2	102.2	102.4	81.2	73.6	65.7	54.3	45.0	38.0
11.0	93.5	93.1	93.0	93.2	76.5	68.5	62.4	54.0	45.0	38.0
12.0	83.4	85.1	85.0	85.2	72.3	64.0	59.3	50.9	44.6	38.0
14.0		71.9	72.8	72.0	65.3	56.5	52.7	45.6	40.4	38.0
16.0		59.2	60.1	59.2	59.5	50.5	47.1	41.3	36.9	35.0
18.0		41.9	50.8	50.0	51.1	45.6	42.6	37.6	33.9	32.3
20.0			43.8	44.8	43.9	41.6	38.8	34.6	31.4	29.6
22.0			38.3	39.3	38.4	37.7	35.5	32.0	29.0	27.2
24.0				34.8	33.8	33.0	32.7	29.7	26.9	25.1
26.0				31.0	29.9	29.2	29.6	27.7	25.1	23.3
28.0				24.4	26.8	25.9	26.8	26.0	23.5	21.7
30.0					24.1	23.2	24.0	24.0	22.1	20.3
32.0					21.8	20.8	21.7	21.7	20.8	19.0
34.0						18.8	19.6	19.6	19.6	17.9
36.0						17.1	17.9	17.8	18.2	16.7
38.0						15.0	16.3	16.4	16.6	15.6
40.0							14.9	15.6	15.2	14.5
42.0							13.7	14.7	13.9	13.6
44.0								13.5	12.8	12.7
46.0								12.6	11.8	11.8
48.0								11.5	10.9	10.9
50.0									10.0	10.0
52.0									9.3	9.3
54.0										8.6
56.0										7.9
58.0										6.2

* mit Zusatzausstattung
* with additional equipment
* avec équipement supplémentaire
* con equipo adicional

MB

Tragfähigkeiten
Lifting capacities
Capacités de levage
Capacidades de elevación





78t

DIN/ISO/EN

 m	15.0 m	20.1 m	25.1 m	30.2 m	35.3 m	40.4 m	45.4 m	50.5 m	55.6 m	60.0 m
3.0	200.0	170.0	162.0							
3.5	200.0	170.0	162.0							
4.0	200.0	170.0	162.0	139.0						
4.5	189.0	170.0	162.0	139.0						
5.0	175.6	170.0	162.0	139.0	123.4					
6.0	153.2	152.8	152.2	139.0	113.8	84.2				
7.0	135.3	134.9	134.3	127.9	103.1	84.2	71.6			
8.0	120.8	120.4	120.3	118.2	94.2	84.2	71.6	54.3		
9.0	107.9	107.5	107.5	107.7	86.7	79.5	69.5	54.3	45.0	
10.0	97.2	96.7	96.7	95.7	81.2	73.6	65.7	54.3	45.0	38.0
11.0	88.2	87.7	87.6	84.7	76.5	68.5	62.4	54.0	45.0	38.0
12.0	77.4	76.8	77.8	75.8	72.3	64.0	59.3	50.9	44.6	38.0
14.0		60.8	61.7	60.9	61.5	56.5	52.7	45.6	40.4	38.0
16.0		51.7	50.7	51.9	51.1	49.4	47.1	41.3	36.9	35.0
18.0		41.9	44.1	43.8	43.0	42.3	41.8	37.6	33.9	32.3
20.0			37.9	37.5	36.6	35.8	36.3	34.6	31.4	29.6
22.0			33.0	32.5	31.5	30.8	31.7	31.8	29.0	27.2
24.0				28.5	27.5	26.7	27.6	27.7	26.9	25.1
26.0				25.3	24.2	23.4	24.3	24.3	24.7	23.3
28.0				22.7	21.5	20.6	21.5	22.0	21.9	21.7
30.0					19.2	18.3	19.2	20.3	19.6	19.7
32.0					17.3	17.3	17.6	18.2	17.5	17.6
34.0						16.4	16.6	16.5	15.7	15.9
36.0						15.6	15.4	14.9	14.2	14.3
38.0						14.7	14.0	13.5	12.8	12.9
40.0							12.8	12.3	11.6	11.7
42.0							11.8	11.2	10.5	10.6
44.0								10.3	9.5	9.6
46.0								9.4	8.6	8.7
48.0								8.7	7.8	7.9
50.0									7.1	7.2
52.0									6.5	6.5
54.0										5.9
56.0										5.4
58.0										4.9

Tragfähigkeiten
Lifting capacities
Capacités de levage
Capacidades de elevación

DIN/ISO/EN

 m	15.0 m	20.1 m	25.1 m	30.2 m	35.3 m	40.4 m	45.4 m	50.5 m	55.6 m	60.0 m
3.0	200.0	170.0	162.0							
3.5	200.0	170.0	162.0							
4.0	198.5	170.0	162.0	139.0						
4.5	183.3	170.0	162.0	139.0						
5.0	170.0	169.6	162.0	139.0	123.4					
6.0	147.8	147.4	146.8	139.0	113.8	84.2				
7.0	129.3	128.9	128.9	123.7	103.1	84.2	71.6			
8.0	113.9	113.4	110.3	103.7	94.2	84.2	71.6	54.3		
9.0	101.2	100.0	95.3	88.8	85.9	79.5	69.5	54.3	45.0	
10.0	85.0	84.4	82.8	77.4	75.3	70.8	65.7	54.3	45.0	38.0
11.0	72.9	72.4	72.9	71.1	66.9	63.0	61.0	54.0	45.0	38.0
12.0	63.6	65.1	64.1	63.7	59.9	56.5	55.0	50.9	44.6	38.0
14.0		51.5	52.1	51.9	49.3	46.5	46.0	44.5	40.4	38.0
16.0		41.8	42.4	42.1	41.1	38.9	38.8	37.6	36.9	35.0
18.0		35.0	35.3	35.0	34.0	33.0	33.1	32.5	31.7	31.0
20.0			29.9	29.5	28.5	27.7	28.6	29.2	27.5	27.0
22.0			26.0	25.2	24.2	24.1	25.4	25.6	24.1	23.7
24.0				23.0	20.8	22.3	22.6	22.1	21.3	20.9
26.0				20.4	18.4	20.2	19.7	19.3	18.6	18.6
28.0				18.3	17.2	17.9	17.4	16.9	16.2	16.4
30.0					15.9	15.9	15.4	15.0	14.2	14.4
32.0					14.4	14.2	13.7	13.3	12.5	12.7
34.0						12.8	12.3	11.8	11.1	11.2
36.0						11.6	11.0	10.5	9.8	9.9
38.0						10.6	9.9	9.4	8.7	8.8
40.0							8.9	8.4	7.7	7.8
42.0							8.1	7.5	6.8	6.9
44.0								6.8	6.0	6.1
46.0								6.1	5.3	5.4
48.0								5.5	4.7	4.7
50.0									4.1	4.1
52.0									3.6	3.6
54.0										3.1
56.0										2.7
58.0										2.3

MB

Tragfähigkeiten
Lifting capacities
Capacités de levage
Capacidades de elevación







47t



DIN/ISO/EN

 m	15.0 m	20.1 m	25.1 m	30.2 m	35.3 m	40.4 m	45.4 m	50.5 m	55.6 m	60.0 m
3.0	200.0	170.0	162.0							
3.5	200.0	170.0	162.0							
4.0	195.3	170.0	162.0	139.0						
4.5	180.1	170.0	162.0	139.0						
5.0	166.8	166.4	162.0	139.0	123.4					
6.0	144.2	143.8	143.0	137.2	113.8	84.2				
7.0	125.0	124.6	119.6	111.3	103.1	84.2	71.6			
8.0	109.8	106.5	100.6	93.1	89.4	83.3	71.6	54.3		
9.0	89.9	89.3	85.6	81.5	77.1	72.1	69.3	54.3	45.0	
10.0	75.3	74.8	74.2	72.1	67.5	63.3	61.1	54.3	45.0	38.0
11.0	64.5	66.0	65.0	63.8	59.8	56.2	54.5	52.9	45.0	38.0
12.0	56.2	57.6	58.2	57.0	53.5	50.2	49.4	47.5	44.6	38.0
14.0		45.4	46.0	45.8	43.4	40.7	40.4	39.0	38.2	37.2
16.0		37.0	37.6	37.3	36.1	33.8	33.8	34.1	32.1	31.4
18.0		30.6	31.1	30.6	29.5	28.7	30.6	29.2	27.4	26.8
20.0			26.2	26.9	24.6	26.2	26.5	25.3	23.7	23.2
22.0			22.5	23.0	21.5	23.1	22.6	22.1	20.6	20.2
24.0				20.0	19.8	19.9	19.4	19.0	18.1	17.8
26.0				17.5	17.3	17.4	16.9	16.4	15.7	15.7
28.0				15.7	15.2	15.3	14.8	14.3	13.6	13.8
30.0					13.5	13.5	13.0	12.5	11.8	12.0
32.0					12.1	12.0	11.5	11.0	10.3	10.4
34.0						10.7	10.2	9.7	9.0	9.1
36.0						9.6	9.0	8.6	7.8	8.0
38.0						8.7	8.1	7.6	6.8	6.9
40.0							7.2	6.7	5.9	6.0
42.0							6.5	5.9	5.2	5.2
44.0								5.2	4.5	4.5
46.0								4.6	3.8	3.9
48.0								4.1	3.3	3.3
50.0									2.7	2.8
52.0									2.3	2.3
54.0										1.9
56.0										1.5

Tragfähigkeiten
Lifting capacities
Capacités de levage
Capacidades de elevación

  36t DIN/ISO/EN										
→ m	15.0 m	20.1 m	25.1 m	30.2 m	35.3 m	40.4 m	45.4 m	50.5 m	55.6 m	60.0 m
3.0	200.0	170.0	162.0							
3.5	200.0	170.0	162.0							
4.0	192.1	170.0	162.0	139.0						
4.5	177.0	170.0	162.0	139.0						
5.0	163.7	163.4	162.0	139.0	123.4					
6.0	139.8	139.3	131.2	120.1	109.8	84.2				
7.0	120.9	113.6	106.2	97.2	92.5	84.2	71.6			
8.0	97.9	92.8	87.9	84.2	78.0	72.4	69.2	54.3		
9.0	79.4	78.2	74.6	72.1	67.1	62.5	60.6	54.3	45.0	
10.0	66.4	68.0	66.5	62.8	58.3	54.3	52.9	50.5	45.0	38.0
11.0	56.7	58.2	58.3	55.0	51.1	47.6	46.8	45.9	43.5	38.0
12.0	49.2	50.7	51.3	48.7	45.3	42.2	41.7	41.5	39.0	37.8
14.0		39.2	39.9	39.2	36.4	35.2	35.9	34.1	31.9	31.1
16.0		31.0	31.8	32.5	30.0	31.6	30.0	28.5	26.7	26.0
18.0		25.5	26.0	26.8	25.8	26.9	25.5	24.2	22.6	22.1
20.0			21.7	22.4	22.3	22.6	22.0	20.8	19.3	18.9
22.0			18.5	19.1	18.9	19.1	18.6	18.0	16.7	16.3
24.0				16.4	16.2	16.4	15.9	15.4	14.4	14.2
26.0				14.3	14.1	14.2	13.7	13.2	12.5	12.3
28.0				12.7	12.3	12.3	11.8	11.4	10.7	10.8
30.0					10.8	10.8	10.3	9.8	9.1	9.2
32.0					9.6	9.5	9.0	8.5	7.8	7.9
34.0						8.4	7.8	7.3	6.6	6.7
36.0						7.4	6.8	6.4	5.6	5.7
38.0						6.7	6.0	5.5	4.8	4.9
40.0							5.2	4.7	4.0	4.1
42.0							4.6	4.0	3.3	3.4
44.0								3.4	2.7	2.8
46.0								2.9	2.1	2.2
48.0								2.5	1.6	1.7

MB

  25t DIN/ISO/EN										
→ m	15.0 m	20.1 m	25.1 m	30.2 m	35.3 m	40.4 m	45.4 m	50.5 m	55.6 m	60.0 m
3.0	200.0	170.0	162.0							
3.5	200.0	170.0	162.0							
4.0	188.2	170.0	162.0	139.0						
4.5	173.1	170.0	162.0	139.0						
5.0	158.5	158.1	144.9	131.4	117.8					
6.0	134.4	122.1	112.2	103.7	95.1	84.2				
7.0	105.9	95.4	89.4	84.9	77.7	71.4	68.0			
8.0	83.8	80.6	76.0	70.6	64.6	59.3	57.2	54.0		
9.0	67.8	67.3	63.7	59.4	54.6	50.3	50.6	48.1	44.7	
10.0	56.4	57.0	54.4	51.0	47.0	45.4	44.8	42.1	39.2	37.8
11.0	47.3	49.1	47.2	44.4	40.9	42.1	39.5	37.3	34.7	33.5
12.0	39.8	41.6	41.8	40.8	36.5	37.4	35.2	33.2	30.9	30.0
14.0		31.2	32.2	32.8	31.4	30.3	28.6	27.0	25.0	24.3
16.0		24.4	25.2	26.1	25.9	25.1	23.7	22.3	20.6	20.1
18.0		19.8	20.4	21.2	21.1	21.2	19.9	18.7	17.2	16.8
20.0			16.8	17.5	17.4	17.6	16.9	15.9	14.5	14.2
22.0			14.1	14.7	14.5	14.7	14.2	13.5	12.2	12.0
24.0				12.5	12.3	12.4	11.9	11.5	10.4	10.2
26.0				10.7	10.5	10.6	10.1	9.6	8.8	8.6
28.0				9.4	9.0	9.1	8.5	8.1	7.4	7.3
30.0					7.8	7.8	7.2	6.8	6.1	6.2
32.0					6.8	6.7	6.1	5.7	5.0	5.1
34.0						5.8	5.2	4.7	4.0	4.1
36.0						5.0	4.4	3.9	3.2	3.3
38.0						4.4	3.7	3.2	2.4	2.5
40.0							3.0	2.5	1.8	1.8
42.0							2.5	1.9		

Tragfähigkeiten
Lifting capacities
Capacités de levage
Capacidades de elevación





16.5t

DIN/ISO/EN

 m	15.0 m	20.1 m	25.1 m	30.2 m	35.3 m	40.4 m	45.4 m	50.5 m	55.6 m	60.0 m
3.0	200.0	170.0	162.0							
3.5	200.0	170.0	162.0							
4.0	185.2	170.0	162.0	139.0						
4.5	168.8	168.4	148.7	132.5						
5.0	154.1	143.9	128.5	114.2	104.3					
6.0	118.9	105.0	97.5	90.5	81.7	73.4				
7.0	90.9	84.9	78.8	72.0	64.9	58.9	57.4			
8.0	71.8	67.8	63.5	58.7	53.3	52.9	49.6	46.1		
9.0	58.2	55.7	53.2	51.1	45.7	45.6	42.5	39.6	36.6	
10.0	47.0	46.9	45.2	43.8	41.4	39.5	36.9	34.5	31.9	30.7
11.0	38.5	40.2	39.1	38.1	36.2	34.6	32.4	30.4	28.0	27.1
12.0	32.2	34.0	34.2	33.6	31.9	30.7	28.7	26.9	24.8	24.0
14.0		25.1	26.1	26.7	25.5	24.6	23.0	21.6	19.8	19.2
16.0		19.4	20.2	21.1	20.9	20.2	18.8	17.6	16.0	15.6
18.0		15.5	16.1	16.9	16.8	16.8	15.6	14.5	13.0	12.7
20.0			13.0	13.7	13.6	13.9	13.0	12.0	10.6	10.3
22.0			10.8	11.4	11.2	11.4	10.9	9.9	8.6	8.4
24.0				9.4	9.2	9.4	8.9	8.2	7.0	6.8
26.0				7.9	7.6	7.7	7.2	6.7	5.6	5.5
28.0				6.8	6.3	6.4	5.9	5.4	4.5	4.4
30.0					5.3	5.3	4.7	4.3	3.5	3.4
32.0					4.4	4.3	3.8	3.3	2.6	2.5
34.0						3.5	3.0	2.5		
36.0						2.9	2.3	1.8		
38.0						2.4	1.7			





7.5t

DIN/ISO/EN

 m	15.0 m	20.1 m	25.1 m	30.2 m	35.3 m	40.4 m	45.4 m	50.5 m	55.6 m	60.0 m
3.0	200.0	170.0	162.0							
3.5	199.3	170.0	162.0							
4.0	180.9	170.0	162.0	139.0						
4.5	163.8	146.8	128.4	115.3						
5.0	141.1	120.3	108.6	98.5	86.6					
6.0	99.1	90.8	82.0	73.4	65.0	63.3				
7.0	73.1	68.0	63.3	59.5	54.8	51.2	46.9			
8.0	56.4	53.6	50.8	48.4	45.1	42.5	39.2	36.2		
9.0	45.2	43.7	42.0	40.5	38.0	36.0	33.3	30.9	28.1	
10.0	36.4	36.5	35.4	34.5	32.5	31.0	28.7	26.6	24.3	23.3
11.0	29.4	31.1	30.4	29.8	28.2	27.0	25.0	23.2	20.9	20.0
12.0	24.3	26.1	26.4	26.1	24.7	23.7	21.8	20.1	18.0	17.4
14.0		18.9	19.9	20.1	19.0	18.3	16.8	15.4	13.7	13.2
16.0		13.9	14.8	15.7	15.0	14.4	13.2	12.0	10.5	10.2
18.0		10.5	11.2	12.0	11.9	11.6	10.5	9.4	8.1	7.8
20.0			8.6	9.4	9.2	9.3	8.3	7.4	6.1	5.9
22.0			6.7	7.3	7.2	7.4	6.6	5.8	4.6	4.4
24.0				5.8	5.6	5.8	5.3	4.4	3.3	
26.0				4.6	4.4	4.5	3.9	3.3		
28.0				3.8	3.3	3.4	2.9			
30.0					2.5	2.5	2.0			
32.0					1.9	1.8				

Tragfähigkeiten
Lifting capacities
Capacités de levage
Capacidades de elevación





0t

DIN/ISO/EN

 m	15.0 m	20.1 m	25.1 m	30.2 m	35.3 m	40.4 m	45.4 m	50.5 m	55.6 m	60.0 m
3.0	200.0	170.0	162.0							
3.5	195.4	170.0	162.0							
4.0	175.4	170.0	162.0	139.0						
4.5	150.6	124.7	112.7	98.4						
5.0	119.8	106.1	93.8	81.2	69.8					
6.0	80.8	73.4	66.9	61.7	55.9	51.4				
7.0	58.0	54.4	51.0	48.0	44.2	41.1	37.4			
8.0	44.2	42.5	40.5	38.8	36.1	33.9	31.0	28.0		
9.0	35.0	34.4	33.2	32.2	30.0	28.1	25.5	23.1	20.4	
10.0	28.0	28.0	27.3	26.7	24.8	23.5	21.3	19.3	17.0	16.2
11.0	22.1	22.9	22.6	22.4	20.9	19.9	18.0	16.3	14.2	13.6
12.0	17.3	19.0	19.0	19.0	17.8	17.0	15.4	13.8	12.0	11.5
14.0		12.9	13.9	14.1	13.3	12.7	11.4	10.1	8.6	8.2
16.0		8.9	9.8	10.7	10.1	9.6	8.5	7.5	6.1	5.8
18.0		6.3	7.0	7.9	7.7	7.4	6.4	5.4		
20.0			5.0	5.8	5.7	5.6	4.7	3.8		
22.0			3.6	4.2	4.0	4.2	3.4			
24.0				3.0	2.8	2.9				
26.0				2.0	1.8	1.9				

MB





0t

DIN/ISO/EN

 m	15.0 m	20.1 m	25.1 m	30.2 m	35.3 m	40.4 m	45.4 m	50.5 m	55.6 m	60.0 m
3.0	200.0	170.0	162.0							
3.5	190.9	170.0	162.0							
4.0	171.1	170.0	162.0	139.0						
4.5	136.7	114.0	97.8	83.7						
5.0	104.2	91.0	80.1	72.6	64.7					
6.0	69.0	63.4	58.3	54.1	49.2	45.4				
7.0	50.2	47.6	44.8	42.5	39.2	36.5	33.3			
8.0	38.6	37.4	35.9	34.5	32.1	30.2	27.6	25.2		
9.0	30.7	30.3	29.5	28.7	26.9	25.4	23.3	21.3	19.0	
10.0	24.5	25.1	24.7		22.8	21.7	19.9	18.2	16.2	15.5
11.0	19.4	21.1	21.0	20.8	19.6	18.7	17.1	15.6	13.8	13.3
12.0	15.7	17.6	18.0	18.0	17.0	16.2	14.8	13.5	11.8	11.4
14.0		12.2	13.2	13.8	13.0	12.5	11.3	10.1	8.6	8.2
16.0		8.7	9.6	10.4	10.1	9.6	8.5	7.5	6.1	5.8
18.0		6.3	7.0	7.8	7.7	7.4	6.4	5.4		
20.0			5.0	5.7	5.6	5.6	4.7	3.8		
22.0			3.6	4.2	4.0	4.2	3.4			
24.0				3.0	2.8	2.9				
26.0				2.0	1.8	1.9				

Hubhöhen
Lifting heights
Hauteurs de levage
Alturas de elevación

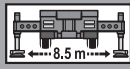
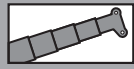

98t

DIN/ISO/EN

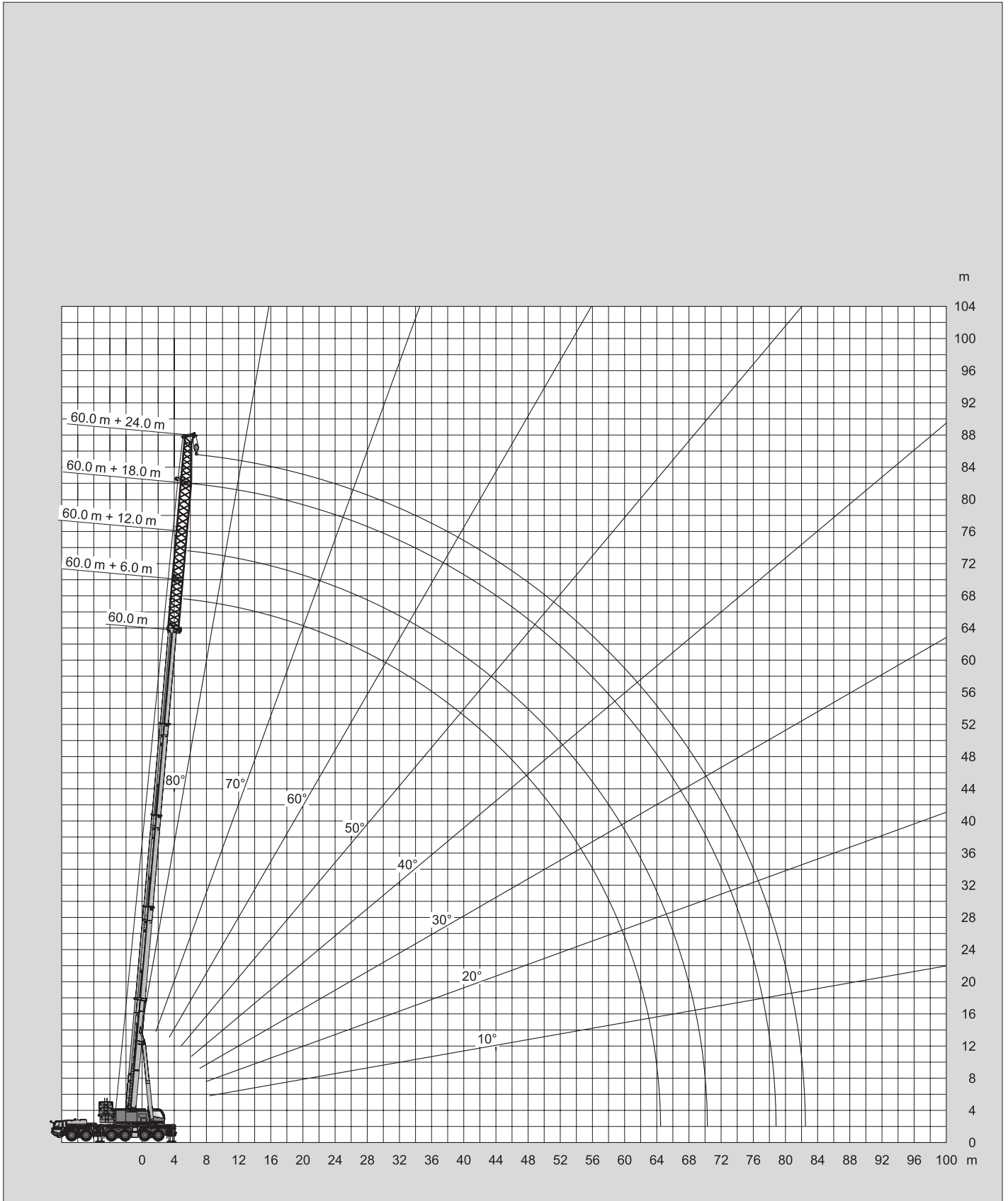

Tragfähigkeiten
Lifting capacities
Capacités de levage
Capacidades de elevación





98t

DIN/ISO/EN

m	LFJ 6.0 m					LFJ 12.0 m					LFJ 18.0 m					LFJ 24.0 m						
	40.4 m	45.4 m	50.5 m	55.6 m	60.0 m	40.4 m	45.4 m	50.5 m	55.6 m	60.0 m	40.4 m	45.4 m	50.5 m	55.6 m	60.0 m	40.4 m	45.4 m	50.5 m	55.6 m	60.0 m		
7.0	54.2																					
8.0	50.7	43.2																				
9.0	47.6	40.8	32.2			43.5																
10.0	44.9	38.6	30.5	26.8		41.0	34.9	27.5			34.3											
11.0	42.5	36.8	29.0	25.5	24.2	38.8	33.1	26.1			32.8	30.2				24.6						
12.0	40.4	35.1	27.6	24.2	23.0	36.8	31.5	24.8	22.1		31.4	28.7	22.9			23.8	22.6					
14.0	36.8	32.2	25.2	22.1	21.0	33.4	28.8	22.6	20.3	19.1	29.0	26.2	20.9	18.2	17.3	22.2	21.4	18.8				
16.0	33.8	29.7	23.3	20.4	19.3	30.6	26.5	20.8	18.7	17.6	26.9	24.1	19.2	16.8	16.0	20.8	20.2	17.3	15.2	13.9		
18.0	31.3	27.5	21.7	18.9	18.0	28.2	24.6	19.3	17.3	16.3	25.0	22.3	17.8	15.7	14.9	19.5	19.1	16.1	14.1	13.4		
20.0	29.2	25.5	20.3	17.7	16.8	26.2	23.0	18.0	16.1	15.2	23.4	20.8	16.5	14.6	13.9	18.2	18.1	15.0	13.1	12.5		
22.0	27.4	23.9	19.1	16.6	15.7	24.5	21.6	16.8	15.0	14.2	22.0	19.5	15.4	13.7	13.1	17.1	17.0	14.1	12.3	11.7		
24.0	25.8	22.4	18.0	15.6	14.8	23.0	20.4	15.9	14.1	13.3	20.7	18.3	14.5	12.9	12.3	16.1	16.1	13.2	11.6	11.0		
26.0	24.4	21.2	17.1	14.8	14.0	21.7	19.3	15.0	13.3	12.6	19.6	17.3	13.6	12.2	11.5	15.2	15.3	12.4	10.9	10.4		
28.0	22.9	20.0	16.2	14.0	13.3	20.5	18.2	14.2	12.6	11.9	18.6	16.4	12.9	11.5	10.9	14.4	14.5	11.7	10.3	9.9		
30.0	21.5	19.0	15.5	13.4	12.6	19.5	17.3	13.5	12.0	11.3	17.6	15.6	12.2	10.9	10.3	13.6	13.8	11.0	9.8	9.4		
32.0	20.3	18.2	14.8	12.8	12.1	18.6	16.4	12.9	11.4	10.7	16.8	14.8	11.6	10.3	9.8	13.0	13.2	10.5	9.3	8.9		
34.0	18.5	17.3	14.3	12.2	11.5	17.7	15.6	12.3	10.9	10.2	16.1	14.2	11.1	9.8	9.3	12.3	12.6	9.9	8.9	8.4		
36.0	16.8	16.6	13.7	11.7	11.1	17.0	14.9	11.8	10.4	9.8	15.4	13.6	10.6	9.4	8.9	11.8	12.0	9.5	8.4	8.0		
38.0	15.2	15.5	13.2	11.3	10.6	15.7	14.3	11.3	9.9	9.4	14.7	13.0	10.1	8.9	8.5	11.3	11.5	9.0	8.0	7.6		
40.0	13.8	14.1	12.8	10.9	10.2	14.3	13.7	10.9	9.5	9.0	14.1	12.5	9.7	8.6	8.1	10.8	11.1	8.6	7.7	7.3		
42.0	12.6	12.9	12.4	10.5	9.9	13.1	13.2	10.5	9.2	8.6	13.6	12.0	9.3	8.2	7.8	10.4	10.7	8.3	7.3	6.9		
44.0	10.9	11.8	12.1	10.2	9.5	11.9	12.1	10.2	8.8	8.3	12.4	11.5	9.0	7.9	7.5	10.0	10.3	7.9	7.0	6.6		
46.0		10.8	11.3	9.8	9.2	10.9	11.1	9.8	8.5	8.0	11.4	11.1	8.7	7.6	7.2	9.6	9.9	7.6	6.7	6.4		
48.0		9.9	10.4	9.6	9.0	10.0	10.2	9.6	8.3	7.7	10.5	10.5	8.4	7.3	6.9	9.3	9.6	7.3	6.5	6.0		
50.0			9.6	9.3	8.7	8.7	9.3	9.3	8.0	7.5	9.6	9.7	8.1	7.1	6.7	9.0	9.3	7.1	6.2	5.7		
54.0			7.8	8.5	8.3		7.9	8.2	7.5	7.0	8.2	8.2	7.6	6.6	6.0	8.3	8.3	6.6	5.8	5.0		
58.0				7.2	7.2			7.0	7.2	6.3			6.9	7.2	6.2	5.4	7.0	7.0	6.2	5.4	4.4	
62.0					6.1					6.2				6.1	5.9	4.8	5.1	5.9	5.0	3.9		
66.0										5.1				5.0	5.4	4.4		5.0	5.1	4.7	3.5	
70.0														4.6	4.0				4.3	4.3	3.1	
74.0															3.7					3.7	2.8	
78.0																					2.5	

MB + LFJ

Tragfähigkeiten
Lifting capacities
Capacités de levage
Capacidades de elevación

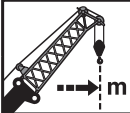

DIN/ISO/EN

 m	LFJ 6.0 m					LFJ 12.0 m					LFJ 18.0 m					LFJ 24.0 m					
	40.4 m	45.4 m	50.5 m	55.6 m	60.0 m	40.4 m	45.4 m	50.5 m	55.6 m	60.0 m	40.4 m	45.4 m	50.5 m	55.6 m	60.0 m	40.4 m	45.4 m	50.5 m	55.6 m	60.0 m	
7.0	54.2																				
8.0	50.7	43.2																			
9.0	47.6	40.8	32.2			43.5															
10.0	44.9	38.6	30.5	26.8		41.0	34.9	27.5			34.3										
11.0	42.5	36.8	29.0	25.5	24.2	38.8	33.1	26.1			32.8	30.2			24.6						
12.0	40.4	35.1	27.6	24.2	23.0	36.8	31.5	24.8	22.1		31.4	28.7	22.9		23.8	22.6					
14.0	36.8	32.2	25.2	22.1	21.0	33.4	28.8	22.6	20.3	19.1	29.0	26.2	20.9	18.2	17.3	22.2	21.4	18.8			
16.0	33.8	29.7	23.3	20.4	19.3	30.6	26.5	20.8	18.7	17.6	26.9	24.1	19.2	16.8	16.0	20.8	20.2	17.3	15.2	13.9	
18.0	31.3	27.5	21.7	18.9	18.0	28.2	24.6	19.3	17.3	16.3	25.0	22.3	17.8	15.7	14.9	19.5	19.1	16.1	14.1	13.4	
20.0	27.1	25.5	20.3	17.7	16.8	26.2	23.0	18.0	16.1	15.2	23.4	20.8	16.5	14.6	13.9	18.2	18.1	15.0	13.1	12.5	
22.0	23.3	23.3	19.1	16.6	15.7	23.5	21.6	16.8	15.0	14.2	22.0	19.5	15.4	13.7	13.1	17.1	17.0	14.1	12.3	11.7	
24.0	19.8	20.3	18.0	15.6	14.8	20.5	20.3	15.9	14.1	13.3	20.7	18.3	14.5	12.9	12.3	16.1	16.1	13.2	11.6	11.0	
26.0	17.0	17.5	17.1	14.8	14.0	17.7	18.0	15.0	13.3	12.6	18.3	17.3	13.6	12.2	11.5	15.2	15.3	12.4	10.9	10.4	
28.0	14.7	15.1	15.8	14.0	13.3	15.4	15.7	14.2	12.6	11.9	16.0	16.0	12.9	11.5	10.9	14.4	14.5	11.7	10.3	9.9	
30.0	12.7	13.1	13.8	13.4	12.6	13.4	13.7	13.5	12.0	11.3	14.0	14.1	12.2	10.9	10.3	13.6	13.8	11.0	9.8	9.4	
32.0	11.1	11.5	12.1	12.6	12.1	11.7	12.0	12.4	11.4	10.7	12.3	12.4	11.6	10.3	9.8	12.7	12.6	10.5	9.3	8.9	
34.0	9.6	10.0	10.7	11.1	11.2	10.2	10.5	10.9	10.9	10.2	10.8	10.9	11.1	9.8	9.3	11.2	11.1	9.9	8.9	8.4	
36.0	8.4	8.7	9.4	9.8	9.9	8.9	9.2	9.6	10.1	9.8	9.5	9.6	10.0	9.4	8.9	9.8	9.8	9.5	8.4	8.0	
38.0	7.3	7.6	8.3	8.7	8.8	7.8	8.1	8.5	8.9	8.8	8.4	8.5	8.9	8.5	8.7	8.7	8.7	8.9	8.0	7.6	
40.0	6.3	6.6	7.3	7.7	7.7	6.8	7.1	7.4	7.9	7.8	7.4	7.4	7.9	8.1	7.9	7.7	7.7	7.9	7.7	7.3	
42.0	5.5	5.8	6.4	6.8	6.8	5.9	6.2	6.5	7.0	6.9	6.5	6.5	6.9	7.2	7.0	6.8	6.8	7.0	7.1	6.9	
44.0	4.8	5.0	5.6	6.0	6.0	5.2	5.4	5.7	6.2	6.1	5.7	5.7	6.1	6.4	6.2	5.9	5.9	6.1	6.3	6.1	
46.0		4.3	4.9	5.3	5.3	4.5	4.7	5.0	5.4	5.3	5.0	5.0	5.4	5.6	5.5	5.2	5.2	5.4	5.6	5.4	
48.0		3.7	4.2	4.6	4.6	3.9	4.0	4.4	4.8	4.7	4.3	4.4	4.7	5.0	4.8	4.5	4.5	4.7	4.9	4.7	
50.0			3.6	4.0	4.0	3.3	3.4	3.8	4.2	4.1	3.7	3.8	4.1	4.4	4.2	3.9	3.9	4.1	4.3	4.1	
54.0			2.7	3.0	3.0		2.4	2.7	3.1	3.0	2.7	2.7	3.1	3.3	3.1	2.9	2.8	3.0	3.2	3.0	
58.0				2.2	2.1			1.9	2.2	2.1		1.9	2.2	2.4	2.2	2.0	2.0	2.1	2.3	2.1	
62.0									1.5				1.6	1.5				1.5			

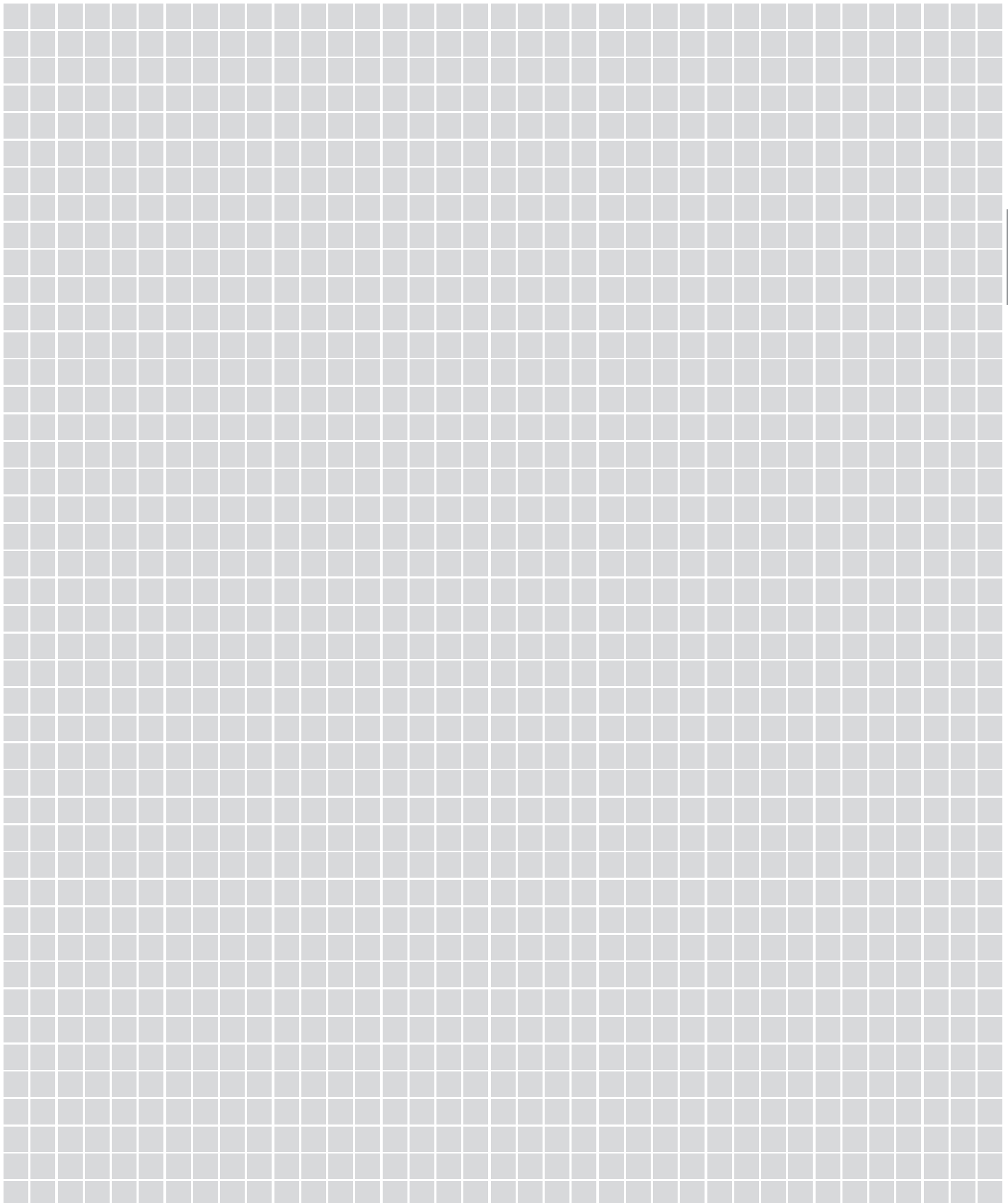

Hubhöhen
Lifting heights
Hauteurs de levage
Alturas de elevación

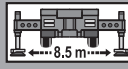
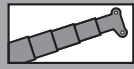

98 t

DIN/ISO/EN

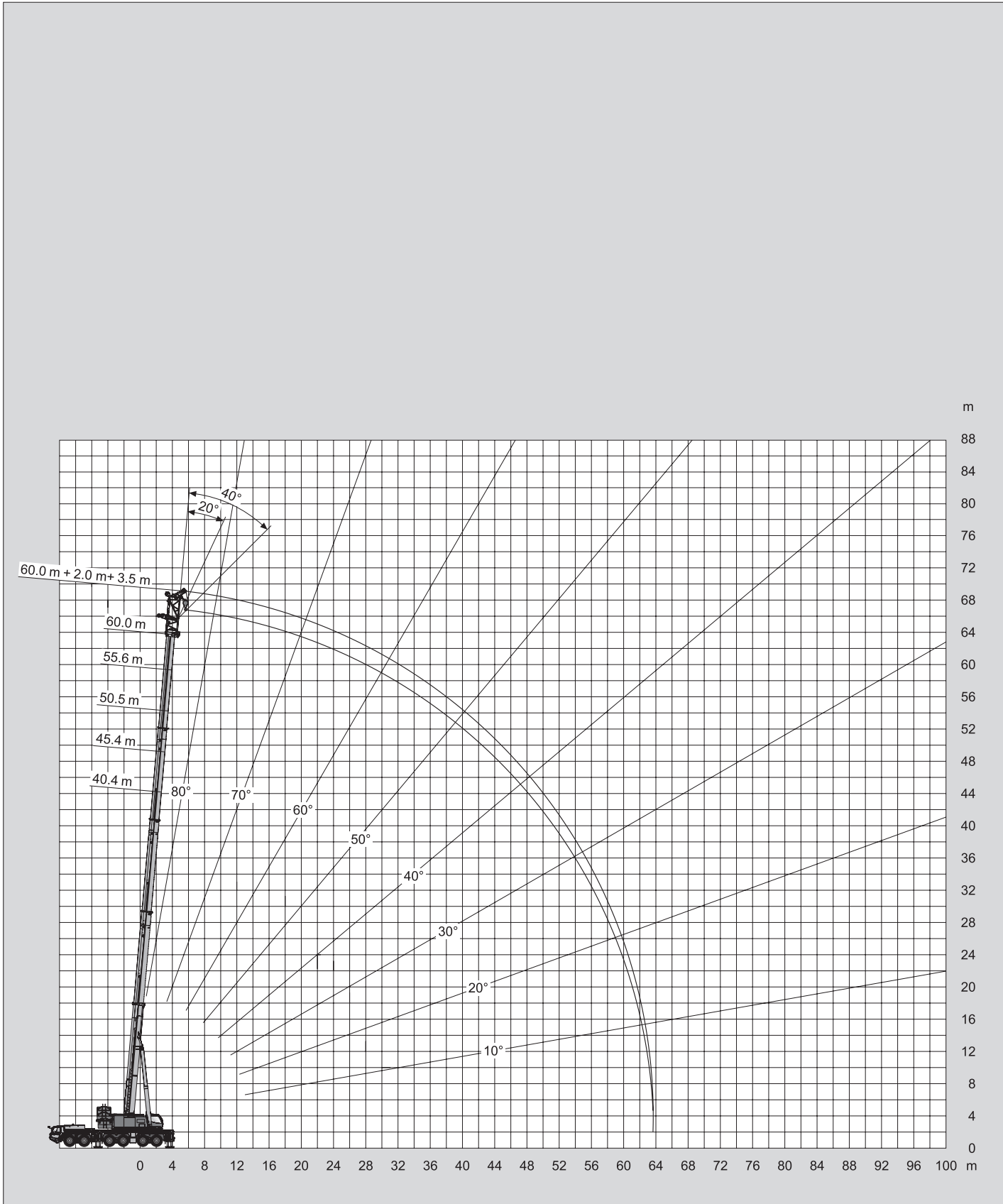

Tragfähigkeiten
Lifting capacities
Capacités de levage
Capacidades de elevación

98t

DIN/ISO/EN

m	40.4 m + 2.0 m + 3.5 m			45.4 m + 2.0 m + 3.5 m			50.5 m + 2.0 m + 3.5 m			55.6 m + 2.0 m + 3.5 m			60.0 m + 2.0 m + 3.5 m		
	0°	20°	40°	0°	20°	40°	0°	20°	40°	0°	20°	40°	0°	20°	40°
8.0	48.2														
9.0	45.4	42.9		38.4											
10.0	42.9	40.7	39.3	36.5	34.3		28.7								
11.0	40.7	38.8	37.5	34.8	32.8	31.4	27.3	25.7			24.1				
12.0	38.7	37.0	35.8	33.2	31.4	30.2	26.0	24.6	23.7	23.0	21.7			21.8	
14.0	35.3	33.9	33.0	30.6	29.1	28.1	23.8	22.7	21.9	21.0	20.2	19.4	19.9	19.1	18.4
16.0	32.5	31.3	30.6	28.4	27.1	26.3	22.0	21.1	20.5	19.4	18.7	18.2	18.4	17.7	17.3
18.0	30.2	29.2	28.6	26.3	25.4	24.7	20.5	19.7	19.2	18.0	17.4	17.0	17.0	16.5	16.1
20.0	28.1	27.3	26.8	24.5	23.9	23.3	19.2	18.5	18.0	16.8	16.3	15.9	15.9	15.4	15.1
22.0	26.4	25.7	25.3	22.9	22.3	22.0	18.0	17.4	17.1	15.7	15.3	15.0	14.9	14.5	14.2
24.0	24.9	24.2	23.9	21.5	21.0	20.8	17.0	16.5	16.2	14.8	14.4	14.2	14.0	13.6	13.4
26.0	23.5	23.0	22.7	20.3	19.9	19.7	16.2	15.7	15.4	14.0	13.6	13.4	13.2	12.9	12.7
28.0	22.1	21.9	21.7	19.2	18.8	18.7	15.4	14.9	14.7	13.3	13.0	12.8	12.5	12.2	12.1
30.0	20.7	20.7	20.7	18.2	17.9	17.8	14.7	14.3	14.1	12.6	12.3	12.2	11.9	11.7	11.5
32.0	19.4	19.5	19.4	17.3	17.1	17.0	14.0	13.7	13.5	12.0	11.8	11.6	11.3	11.1	11.0
34.0	17.3	17.5	17.5	16.6	16.3	16.2	13.5	13.2	13.0	11.5	11.3	11.2	10.8	10.6	10.5
36.0	15.5	15.6	15.7	15.8	15.7	15.6	13.0	12.7	12.6	11.0	10.8	10.7	10.4	10.2	10.1
38.0	13.9	14.0		14.2	14.4	14.4	12.5	12.3	12.2	10.6	10.4	10.3	9.9	9.8	9.7
40.0	12.5	12.6		12.8	12.9	12.9	12.1	11.9	11.8	10.2	10.0	10.0	9.6	9.4	9.3
42.0	11.3	11.3		11.5	11.6		11.7	11.5	11.5	9.8	9.7	9.6	9.2	9.1	9.0
44.0	5.5			10.4	10.5		11.0	11.1	11.1	9.5	9.4	9.3	8.9	8.7	8.7
46.0				9.4	9.5		10.0	10.0		9.2	9.1	9.1	8.6	8.5	8.4
48.0				8.5			9.0	9.1		8.9	8.8	8.8	8.3	8.2	8.2
50.0							8.2	8.2		8.7	8.6		8.1	8.0	7.9
54.0							4.1			7.2	7.2		7.1	7.2	
58.0										5.9			5.9	5.9	
62.0													4.8	4.8	

MB
+ Heavy Duty

58t

DIN/ISO/EN

m	40.4 m + 2.0 m + 3.5 m			45.4 m + 2.0 m + 3.5 m			50.5 m + 2.0 m + 3.5 m			55.6 m + 2.0 m + 3.5 m			60.0 m + 2.0 m + 3.5 m		
	0°	20°	40°	0°	20°	40°	0°	20°	40°	0°	20°	40°	0°	20°	40°
8.0	48.2														
9.0	45.4	42.9		38.4											
10.0	42.9	40.7	39.3	36.5	34.3		28.7								
11.0	40.7	38.8	37.5	34.8	32.8	31.4	27.3	25.7			24.1				
12.0	38.7	37.0	35.8	33.2	31.4	30.2	26.0	24.6	23.7	23.0	21.7			21.8	
14.0	35.3	33.9	33.0	30.6	29.1	28.1	23.8	22.7	21.9	21.0	20.2	19.4	19.9	19.1	18.4
16.0	32.5	31.3	30.6	28.4	27.1	26.3	22.0	21.1	20.5	19.4	18.7	18.2	18.4	17.7	17.3
18.0	30.2	29.2	28.6	26.3	25.4	24.7	20.5	19.7	19.2	18.0	17.4	17.0	17.0	16.5	16.1
20.0	26.0	26.6	26.8	24.5	23.9	23.3	19.2	18.5	18.0	16.8	16.3	15.9	15.9	15.4	15.1
22.0	22.2	22.7	23.1	22.1	22.3	22.0	18.0	17.4	17.1	15.7	15.3	15.0	14.9	14.5	14.2
24.0	18.7	19.2	19.4	19.1	19.5	19.8	17.0	16.5	16.2	14.8	14.4	14.2	14.0	13.6	13.4
26.0	15.9	16.3	16.5	16.2	16.6	16.9	16.2	15.7	15.4	14.0	13.6	13.4	13.2	12.9	12.7
28.0	13.5	13.8	14.0	13.9	14.2	14.4	14.5	14.9	14.7	13.3	13.0	12.8	12.5	12.2	12.1
30.0	11.5	11.8	11.9	11.9	12.2	12.3	12.5	12.9	13.0	12.6	12.3	12.2	11.9	11.7	11.5
32.0	9.8	10.1	10.2	10.2	10.4	10.6	10.8	11.1	11.3	11.4	11.7	11.6	11.3	11.1	11.0
34.0	8.4	8.6	8.6	8.7	8.9	9.0	9.3	9.6	9.7	9.9	10.2	10.3	10.0	10.3	10.4
36.0	7.1	7.3	7.3	7.4	7.6	7.7	8.1	8.3	8.4	8.6	8.9	9.0	8.7	8.9	9.1
38.0	6.0	6.1		6.3	6.5	6.5	6.9	7.1	7.2	7.5	7.7	7.8	7.5	7.8	7.9
40.0	5.0	5.1		5.3	5.4	5.4	5.9	6.1	6.1	6.5	6.6	6.7	6.5	6.7	6.8
42.0	4.2	4.2		4.4	4.5		5.0	5.2	5.2	5.6	5.7	5.8	5.6	5.8	5.9
44.0	3.5			3.6	3.7		4.2	4.3	4.3	4.7	4.9	4.9	4.8	4.9	5.0
46.0				3.0	3.0		3.5	3.6		4.0	4.1	4.2	4.1	4.2	4.2
48.0				2.3			2.9	2.9		3.4	3.5	3.5	3.4	3.5	3.5
50.0							2.3	2.3		2.8	2.8		2.8	2.9	2.9
54.0										1.7	1.8		1.7	1.8	

Hubhöhen
Lifting heights
Hauteurs de levage
Alturas de elevación

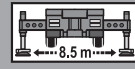
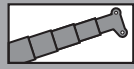

98t

DIN/ISO/EN

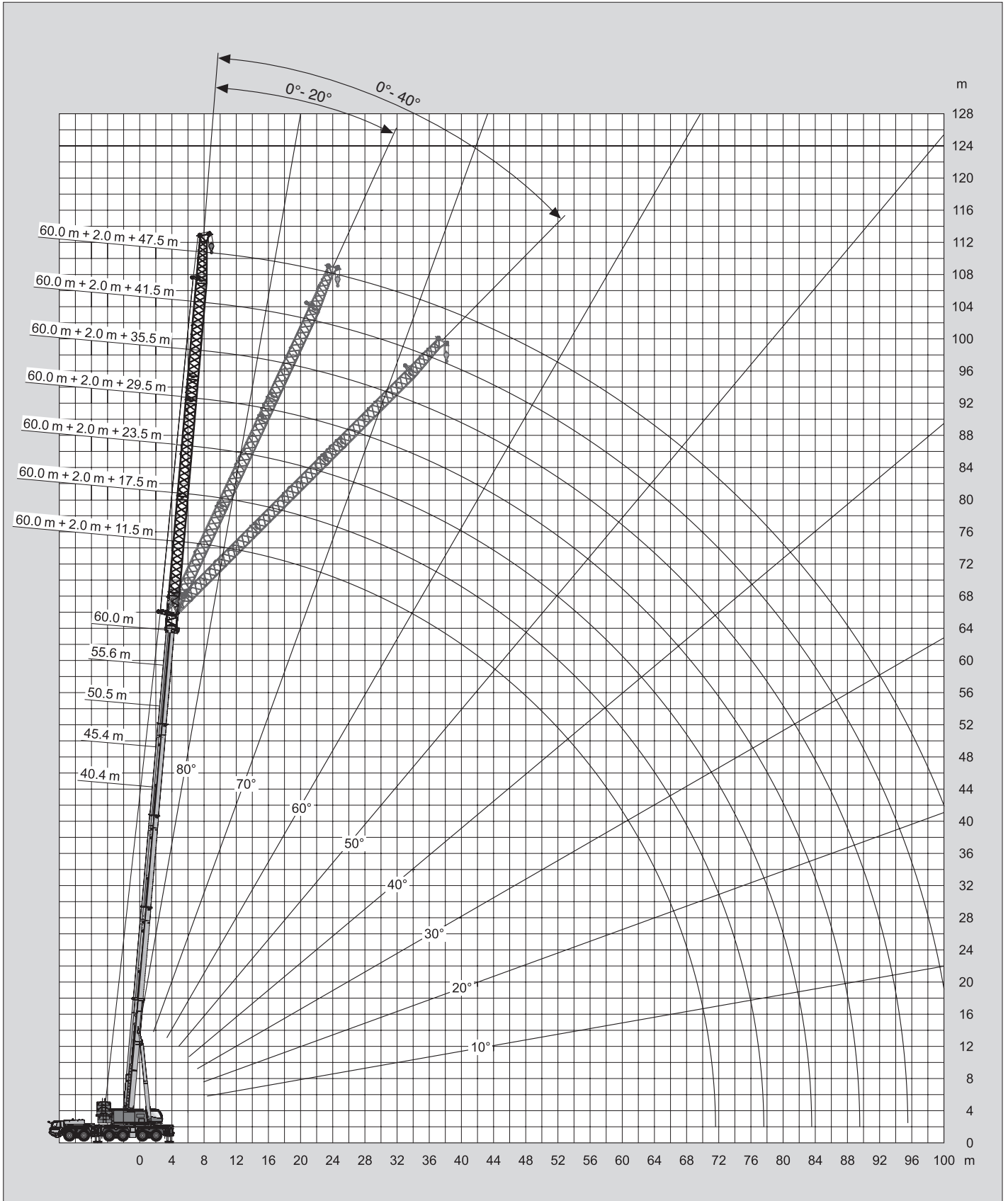

Tragfähigkeiten
Lifting capacities
Capacités de levage
Capacidades de elevación

DIN/ISO/EN

m	40.4 m + 2.0 m + 11.5 m			45.4 m + 2.0 m + 11.5 m			50.5 m + 2.0 m + 11.5 m			55.6 m + 2.0 m + 11.5 m			60.0 m + 2.0 m + 11.5 m		
	0°	20°	40°	0°	20°	40°	0°	20°	40°	0°	20°	40°	0°	20°	40°
9.0	41.7														
10.0	39.2			33.2											
11.0	37.1			31.5			24.8								
12.0	35.1			29.9			23.5			20.8					
14.0	31.9	27.6		27.3	23.7		21.4			19.0			18.0		
16.0	29.1	26.1	22.7	25.1	22.1		19.6	16.9		17.6	15.0		16.6		
18.0	26.9	24.5	21.8	23.3	20.6	19.0	18.1	16.0	14.1	16.2	14.1		15.3	13.4	
20.0	24.9	22.9	21.0	21.7	19.4	17.9	16.9	15.2	13.5	15.0	13.3	12.1	14.2	12.6	
22.0	23.3	21.5	20.3	20.3	18.3	17.0	15.8	14.3	13.0	14.0	12.6	11.5	13.2	12.0	11.0
24.0	21.8	20.2	19.2	19.1	17.3	16.2	14.8	13.5	12.5	13.1	12.0	11.0	12.4	11.4	10.5
26.0	20.5	19.1	18.3	18.1	16.5	15.5	13.9	12.8	12.0	12.4	11.4	10.6	11.6	10.8	10.0
28.0	19.4	18.1	17.4	17.1	15.7	14.8	13.2	12.1	11.5	11.7	10.9	10.1	11.0	10.3	9.6
30.0	18.4	17.3	16.6	16.2	15.0	14.2	12.5	11.6	11.0	11.0	10.3	9.8	10.4	9.7	9.3
32.0	17.4	16.5	15.9	15.4	14.4	13.7	11.9	11.0	10.5	10.5	9.8	9.4	9.8	9.3	8.9
34.0	16.6	15.8	15.3	14.6	13.8	13.2	11.3	10.6	10.1	9.9	9.4	9.0	9.4	8.8	8.5
36.0	15.9	15.1	14.7	13.9	13.3	12.7	10.8	10.1	9.7	9.5	9.0	8.6	8.9	8.4	8.2
38.0	14.7	14.5	14.1	13.3	12.8	12.3	10.4	9.7	9.4	9.0	8.6	8.3	8.5	8.1	7.8
40.0	13.3	13.9	13.7	12.7	12.3	12.0	10.0	9.4	9.0	8.7	8.2	8.0	8.1	7.7	7.5
42.0	12.0	12.5	12.8	12.2	11.8	11.6	9.6	9.0	8.7	8.3	7.9	7.7	7.8	7.4	7.2
44.0	10.9	11.3	11.5	11.0	11.4	11.2	9.2	8.7	8.5	8.0	7.6	7.4	7.5	7.1	7.0
46.0	9.9	10.2		10.0	10.5	10.7	8.9	8.4	8.2	7.7	7.3	7.1	7.2	6.9	6.7
48.0	8.9	9.2		9.1	9.5	9.6	8.6	8.2	8.0	7.4	7.1	6.9	6.9	6.6	6.5
50.0	8.1	8.3		8.2	8.6		8.4	8.0	7.8	7.1	6.8	6.7	6.5	6.3	6.3
54.0				6.7	6.9		7.0	7.3		6.7	6.4	6.3	5.7	5.6	5.6
58.0							5.8	6.0		6.1	6.1	6.0	5.1	5.0	5.1
62.0							2.0			5.0	5.2		4.5	4.5	4.6
66.0										4.0	4.1		3.9	4.0	
70.0													3.1	3.1	

DIN/ISO/EN

m	40.4 m + 2.0 m + 11.5 m			45.4 m + 2.0 m + 11.5 m			50.5 m + 2.0 m + 11.5 m			55.6 m + 2.0 m + 11.5 m			60.0 m + 2.0 m + 11.5 m		
	0°	20°	40°	0°	20°	40°	0°	20°	40°	0°	20°	40°	0°	20°	40°
9.0	41.7														
10.0	39.2			33.2											
11.0	37.1			31.5			24.8								
12.0	35.1			29.9			23.5			20.8					
14.0	31.9	27.6		27.3	23.7		21.4			19.0			18.0		
16.0	29.1	26.1	22.7	25.1	22.1		19.6	16.9		17.6	15.0		16.6		
18.0	26.9	24.5	21.8	23.3	20.6	19.0	18.1	16.0	14.1	16.2	14.1		15.3	13.4	
20.0	24.9	22.9	21.0	21.7	19.4	17.9	16.9	15.2	13.5	15.0	13.3	12.1	14.2	12.6	
22.0	22.2	21.5	20.3	20.3	18.3	17.0	15.8	14.3	13.0	14.0	12.6	11.5	13.2	12.0	11.0
24.0	19.3	20.2	19.2	19.0	17.3	16.2	14.8	13.5	12.5	13.1	12.0	11.0	12.4	11.4	10.5
26.0	16.7	18.2	18.3	16.7	16.5	15.5	13.9	12.8	12.0	12.4	11.4	10.6	11.6	10.8	10.0
28.0	14.3	15.7	16.7	14.6	15.7	14.8	13.2	12.1	11.5	11.7	10.9	10.1	11.0	10.3	9.6
30.0	12.4	13.5	14.4	12.6	13.8	14.2	12.5	11.6	11.0	11.0	10.3	9.8	10.4	9.7	9.3
32.0	10.6	11.7	12.5	10.9	12.0	12.8	11.2	11.0	10.5	10.5	9.8	9.4	9.8	9.3	8.9
34.0	9.2	10.1	10.8	9.4	10.4	11.1	9.7	10.6	10.1	9.9	9.4	9.0	9.4	8.8	8.5
36.0	7.9	8.7	9.3	8.1	9.0	9.6	8.5	9.3	9.7	8.9	9.0	8.6	8.7	8.4	8.2
38.0	6.8	7.5	8.0	7.0	7.8	8.3	7.3	8.1	8.7	7.7	8.6	8.3	7.6	8.1	7.8
40.0	5.8	6.4	6.8	6.0	6.7	7.1	6.3	7.0	7.5	6.7	7.5	8.0	6.6	7.4	7.5
42.0	4.9	5.4	5.7	5.1	5.7	6.1	5.4	6.1	6.5	5.8	6.5	7.0	5.7	6.4	6.9
44.0	4.1	4.6	4.8	4.3	4.8	5.1	4.6	5.2	5.6	5.0	5.6	6.0	4.9	5.5	6.0
46.0	3.4	3.8		3.5	4.0	4.3	3.9	4.4	4.7	4.3	4.8	5.2	4.1	4.7	5.1
48.0	2.8	3.1		2.9	3.3	3.5	3.2	3.7	4.0	3.6	4.1	4.4	3.5	4.0	4.4
50.0	2.2	2.4		2.3	2.7		2.6	3.0	3.2	3.0	3.5	3.7	2.8	3.4	3.7
54.0				1.5			1.6	1.9		1.9	2.3	2.5	1.8	2.2	2.4

Tragfähigkeiten
Lifting capacities
Capacités de levage
Capacidades de elevación

98t

DIN/ISO/EN

--- m	40.4 m + 2.0 m + 17.5 m			45.4 m + 2.0 m + 17.5 m			50.5 m + 2.0 m + 17.5 m			55.6 m + 2.0 m + 17.5 m			60.0 m + 2.0 m + 17.5 m		
	0°	20°	40°	0°	20°	40°	0°	20°	40°	0°	20°	40°	0°	20°	40°
10.0	32.8														
11.0	31.5			28.7											
12.0	30.3			27.3			21.5								
14.0	28.1			24.8			19.7			17.1					
16.0	26.3	20.6		22.8			18.1			15.8			14.9		
18.0	24.7	19.5		21.1	18.0		16.7	13.5		14.6			13.8		
20.0	23.0	18.6		19.6	17.0		15.5	12.8		13.6	11.4		12.9		
22.0	21.4	17.8	15.4	18.3	16.0		14.4	12.2		12.7	10.8		12.1	10.3	
24.0	20.1	17.1	14.9	17.2	15.1	13.8	13.5	11.6	10.2	12.0	10.2		11.3	9.7	
26.0	18.8	16.4	14.5	16.2	14.3	13.2	12.7	11.1	9.8	11.2	9.7	8.7	10.6	9.3	8.4
28.0	17.8	15.8	14.0	15.3	13.6	12.6	11.9	10.6	9.4	10.6	9.3	8.4	10.0	8.8	8.0
30.0	16.8	15.3	13.6	14.5	13.0	12.1	11.3	10.2	9.1	10.0	8.9	8.1	9.4	8.4	7.7
32.0	15.9	14.8	13.3	13.8	12.4	11.6	10.7	9.7	8.8	9.4	8.5	7.8	8.9	8.1	7.4
34.0	15.1	14.1	13.0	13.1	11.9	11.2	10.2	9.3	8.5	8.9	8.1	7.5	8.4	7.7	7.1
36.0	14.4	13.5	12.7	12.6	11.4	10.8	9.7	8.9	8.3	8.5	7.8	7.2	8.0	7.4	6.9
38.0	13.8	12.9	12.4	12.0	11.0	10.4	9.2	8.5	8.0	8.1	7.5	7.0	7.6	7.1	6.6
40.0	13.2	12.4	12.0	11.5	10.6	10.0	8.8	8.1	7.7	7.7	7.2	6.8	7.3	6.8	6.4
42.0	12.5	11.9	11.5	11.1	10.2	9.7	8.5	7.8	7.5	7.4	6.9	6.5	6.9	6.5	6.2
44.0	11.3	11.5	11.2	10.6	9.9	9.4	8.1	7.5	7.2	7.0	6.6	6.4	6.6	6.2	6.0
46.0	10.3	11.0	10.8	10.2	9.6	9.2	7.8	7.3	7.0	6.7	6.4	6.1	6.3	6.0	5.8
48.0	9.3	10.0	10.3	9.3	9.3	8.9	7.5	7.0	6.8	6.5	6.1	5.9	5.9	5.6	5.6
50.0	8.5	9.0	9.3	8.5	9.0	8.7	7.3	6.8	6.6	6.2	5.9	5.7	5.5	5.3	5.3
54.0	7.0	7.3		7.0	7.5	7.7	6.8	6.4	6.2	5.8	5.5	5.3	4.8	4.7	4.7
58.0				5.7	6.0		6.0	6.0	5.9	5.3	5.1	5.0	4.2	4.1	4.2
62.0				4.4	4.8		4.9	5.2		4.8	4.7	4.6	3.6	3.6	3.7
66.0							3.9	4.1		4.1	4.3		3.2	3.2	3.3
70.0										3.3	3.4		2.8	2.8	
74.0													2.3	2.5	

58t

DIN/ISO/EN

--- m	40.4 m + 2.0 m + 17.5 m			45.4 m + 2.0 m + 17.5 m			50.5 m + 2.0 m + 17.5 m			55.6 m + 2.0 m + 17.5 m			60.0 m + 2.0 m + 17.5 m		
	0°	20°	40°	0°	20°	40°	0°	20°	40°	0°	20°	40°	0°	20°	40°
10.0	32.8														
11.0	31.5			28.7											
12.0	30.3			27.3			21.5								
14.0	28.1			24.8			19.7			17.1					
16.0	26.3	20.6		22.8			18.1			15.8			14.9		
18.0	24.7	19.5		21.1	18.0		16.7	13.5		14.6			13.8		
20.0	23.0	18.6		19.6	17.0		15.5	12.8		13.6	11.4		12.9		
22.0	21.4	17.8	15.4	18.3	16.0		14.4	12.2		12.7	10.8		12.1	10.3	
24.0	19.4	17.1	14.9	17.2	15.1	13.8	13.5	11.6	10.2	12.0	10.2		11.3	9.7	
26.0	17.0	16.4	14.5	16.2	14.3	13.2	12.7	11.1	9.8	11.2	9.7	8.7	10.6	9.3	8.4
28.0	15.0	15.8	14.0	14.6	13.6	12.6	11.9	10.6	9.4	10.6	9.3	8.4	10.0	8.8	8.0
30.0	12.9	14.7	13.6	12.9	13.0	12.1	11.3	10.2	9.1	10.0	8.9	8.1	9.4	8.4	7.7
32.0	11.2	12.8	13.3	11.2	12.4	11.6	10.7	9.7	8.8	9.4	8.5	7.8	8.9	8.1	7.4
34.0	9.7	11.2	12.3	9.7	11.2	11.2	10.1	9.3	8.5	8.9	8.1	7.5	8.4	7.7	7.1
36.0	8.4	9.7	10.8	8.4	9.8	10.8	8.8	8.9	8.3	8.5	7.8	7.2	8.0	7.4	6.9
38.0	7.3	8.5	9.4	7.3	8.5	9.5	7.7	8.5	8.0	7.9	7.5	7.0	7.6	7.1	6.6
40.0	6.3	7.3	8.1	6.3	7.4	8.3	6.6	7.8	7.7	6.8	7.2	6.8	6.7	6.8	6.4
42.0	5.4	6.3	7.0	5.4	6.4	7.1	5.7	6.8	7.5	5.9	6.9	6.5	5.7	6.5	6.2
44.0	4.6	5.4	6.0	4.6	5.5	6.1	4.9	5.9	6.6	5.1	6.1	6.4	4.9	6.0	6.0
46.0	3.8	4.6	5.0	3.8	4.7	5.2	4.2	5.0	5.7	4.4	5.3	5.9	4.2	5.1	5.8
48.0	3.2	3.8	4.2	3.2	3.9	4.4	3.5	4.3	4.8	3.7	4.5	5.1	3.5	4.4	5.1
50.0	2.6	3.1	3.4	2.6	3.2	3.6	2.9	3.6	4.1	3.1	3.8	4.4	2.9	3.7	4.3
54.0	1.6	1.9		1.5	2.0	2.2	1.8	2.4	2.7	2.0	2.7	3.1	1.8	2.5	3.0
58.0									1.6		1.6	1.9			1.9

Tragfähigkeiten
Lifting capacities
Capacités de levage
Capacidades de elevación

--- m	40.4 m + 2.0 m + 23.5 m			45.4 m + 2.0 m + 23.5 m			50.5 m + 2.0 m + 23.5 m			55.6 m + 2.0 m + 23.5 m			60.0 m + 2.0 m + 23.5 m		
	0°	20°	40°	0°	20°	40°	0°	20°	40°	0°	20°	40°	0°	20°	40°
11.0	26.7														
12.0	25.7														
14.0	23.9			22.1			17.8								
16.0	22.2			20.7			16.3				14.3			13.6	
18.0	20.8			19.4			15.1				13.2			12.6	
20.0	19.6	15.3		18.1			14.1				12.3			11.7	
22.0	18.5	14.6		16.9	13.8		13.2	10.4			11.5			10.9	
24.0	17.5	13.9		15.8	13.2		12.3	9.9			10.8	8.9		10.2	
26.0	16.6	13.3	10.9	14.8	12.6		11.5	9.5			10.1	8.4		9.6	8.1
28.0	15.8	12.8	10.6	14.0	12.2	10.5	10.9	9.0			9.5	8.0		9.1	7.7
30.0	15.1	12.3	10.3	13.2	11.6	10.2	10.2	8.7	7.6		9.0	7.6	6.8	8.6	7.3
32.0	14.5	11.9	10.0	12.5	11.1	9.9	9.7	8.3	7.3		8.6	7.3	6.5	8.1	7.0
34.0	13.9	11.4	9.8	11.9	10.6	9.7	9.2	8.0	7.0		8.1	7.0	6.3	7.7	6.7
36.0	13.3	11.1	9.5	11.3	10.1	9.4	8.7	7.7	6.8		7.7	6.7	6.1	7.3	6.4
38.0	12.7	10.7	9.3	10.8	9.7	9.0	8.3	7.4	6.6		7.3	6.4	5.8	6.9	6.1
40.0	12.1	10.4	9.1	10.4	9.3	8.7	7.9	7.1	6.4		6.9	6.2	5.6	6.5	5.9
42.0	11.6	10.1	8.9	9.9	9.0	8.4	7.5	6.9	6.2		6.6	5.9	5.4	6.2	5.7
44.0	11.1	9.8	8.8	9.5	8.6	8.1	7.2	6.6	6.1		6.3	5.7	5.3	5.8	5.4
46.0	10.6	9.6	8.7	9.2	8.3	7.9	6.9	6.3	5.9		6.0	5.5	5.1	5.4	5.1
48.0	9.7	9.3	8.5	8.8	8.1	7.6	6.6	6.1	5.8		5.7	5.3	4.9	5.0	4.8
50.0	8.8	9.1	8.4	8.5	7.8	7.4	6.4	5.9	5.6		5.4	5.1	4.8	4.6	4.4
54.0	7.3	8.0	8.3	7.2	7.3	7.0	5.9	5.5	5.2		4.8	4.6	4.4	4.0	3.9
58.0	6.0	6.5	6.6	5.9	6.6	6.7	5.4	5.1	4.9		4.3	4.1	4.0	3.4	3.4
62.0	4.9	5.1		4.8	5.3	5.4	4.9	4.7	4.5		3.8	3.7	3.6	2.9	2.9
66.0				3.9	4.1		4.0	4.3	4.3		3.5	3.3	3.3	2.5	2.5
70.0							3.1	3.4			3.1	3.0	3.0	2.1	2.1
74.0											2.5	2.8		1.8	1.8
78.0											1.8	2.0		1.5	1.6

MB+FJ

--- m	40.4 m + 2.0 m + 23.5 m			45.4 m + 2.0 m + 23.5 m			50.5 m + 2.0 m + 23.5 m			55.6 m + 2.0 m + 23.5 m			60.0 m + 2.0 m + 23.5 m		
	0°	20°	40°	0°	20°	40°	0°	20°	40°	0°	20°	40°	0°	20°	40°
11.0	26.7														
12.0	25.7														
14.0	23.9			22.1			17.8								
16.0	22.2			20.7			16.3				14.3			13.6	
18.0	20.8			19.4			15.1				13.2			12.6	
20.0	19.6	15.3		18.1			14.1				12.3			11.7	
22.0	18.5	14.6		16.9	13.8		13.2	10.4			11.5			10.9	
24.0	17.5	13.9		15.8	13.2		12.3	9.9			10.8	8.9		10.2	
26.0	16.6	13.3	10.9	14.8	12.6		11.5	9.5			10.1	8.4		9.6	8.1
28.0	15.8	12.8	10.6	14.0	12.2	10.5	10.9	9.0			9.5	8.0		9.1	7.7
30.0	15.1	12.3	10.3	12.9	11.6	10.2	10.2	8.7	7.6		9.0	7.6	6.8	8.6	7.3
32.0	14.5	11.9	10.0	12.5	11.1	9.9	9.7	8.3	7.3		8.6	7.3	6.5	8.1	7.0
34.0	13.9	11.4	9.8	12.1	10.6	9.7	9.2	8.0	7.0		8.1	7.0	6.3	7.7	6.7
36.0	13.3	11.1	9.5	11.7	10.1	9.4	8.7	7.7	6.8		7.7	6.7	6.1	7.3	6.4
38.0	12.7	10.7	9.3	11.3	9.3	9.0	8.3	7.4	6.6		7.3	6.4	5.8	6.9	6.1
40.0	12.1	10.4	9.1	10.8	9.3	8.7	7.8	7.1	6.4		6.9	6.2	5.6	6.5	5.9
42.0	11.6	10.1	8.9	10.4	9.0	8.3	7.5	6.9	6.2		6.0	5.9	5.4	5.7	5.7
44.0	11.1	9.8	8.8	10.0	8.6	8.1	7.2	6.6	6.1		5.7	5.3	4.9	5.4	5.4
46.0	10.6	9.6	8.7	9.6	8.3	7.9	6.9	6.3	5.9		5.2	5.7	5.3	4.9	5.4
48.0	9.7	9.3	8.5	9.2	8.1	7.6	6.6	6.1	5.8		5.0	4.9	4.5	4.2	4.7
50.0	8.8	9.1	8.4	8.8	7.8	7.4	6.4	5.9	5.6		4.8	4.9	4.9	4.0	4.3
54.0	7.3	8.0	8.3	8.1	7.3	7.0	5.9	5.5	5.2		4.4	4.6	4.8	3.5	4.7
58.0	6.0	6.5	6.6	7.7	6.6	6.7	5.4	5.1	4.9		4.1	4.2	4.8	2.9	4.0
62.0	4.9	5.1		6.6	5.3	5.4	4.9	4.7	4.5		3.8	3.7	3.6		
66.0				5.4	4.1		4.0	4.3	4.3		3.5	3.3	3.3	2.5	2.5
70.0							3.1	3.4			3.1	3.0	3.0	2.1	2.1
74.0											2.5	2.8		1.8	1.8
78.0											1.8	2.0		1.5	1.6

Tragfähigkeiten
Lifting capacities
Capacités de levage
Capacidades de elevación



 m	40.4 m + 2.0 m + 29.5 m			45.4 m + 2.0 m + 29.5 m			50.5 m + 2.0 m + 29.5 m			55.6 m + 2.0 m + 29.5 m			60.0 m + 2.0 m + 29.5 m		
	0°	20°	40°	0°	20°	40°	0°	20°	40°	0°	20°	40°	0°	20°	40°
12.0	21.9														
14.0	20.4			18.9											
16.0	19.0			17.7			14.8			13.6					
18.0	17.8			16.7			13.7			12.5			11.9		
20.0	16.7			15.7			12.7			11.6			11.0		
22.0	15.8			14.9			11.9			10.7			10.2		
24.0	14.9	10.9		14.1	10.8		11.1			10.0			9.6		
26.0	14.1	10.4		13.4	10.3		10.5	8.2		9.4			9.0		
28.0	13.4	10.0		12.7	9.9		9.9	7.9		8.8	7.2		8.4		
30.0	12.8	9.6		12.1	9.5		9.3	7.5		8.3	6.9		7.9	6.6	
32.0	12.2	9.2	7.5	11.4	9.1	7.5	8.8	7.2		7.9	6.6		7.5	6.3	
34.0	11.6	8.8	7.3	10.8	8.8	7.3	8.3	6.9	6.0	7.5	6.3		7.1	5.9	
36.0	11.1	8.5	7.1	10.3	8.5	7.1	7.9	6.6	5.7	7.1	6.0	5.3	6.7	5.5	
38.0	10.6	8.2	6.9	9.8	8.2	6.9	7.5	6.3	5.5	6.7	5.7	5.1	6.4	5.2	4.4
40.0	10.1	7.9	6.8	9.3	7.9	6.7	7.1	6.1	5.4	6.4	5.5	4.9	5.9	4.9	4.2
42.0	9.7	7.7	6.6	8.9	7.7	6.5	6.8	5.9	5.2	6.1	5.2	4.7	5.4	4.6	4.0
44.0	9.3	7.4	6.4	8.5	7.4	6.4	6.4	5.7	5.0	5.8	5.0	4.6	5.0	4.3	3.8
46.0	8.9	7.2	6.3	8.2	7.2	6.3	6.1	5.5	4.9	5.4	4.8	4.4	4.6	4.1	3.6
48.0	8.6	7.0	6.2	7.8	7.0	6.1	5.9	5.3	4.7	5.1	4.7	4.2	4.2	3.9	3.4
50.0	8.3	6.8	6.1	7.5	6.8	6.0	5.5	5.1	4.6	4.7	4.4	4.1	3.9	3.6	3.3
54.0	7.4	6.5	5.9	7.0	6.3	5.8	4.9	4.5	4.3	4.1	3.9	3.8	3.3	3.2	3.0
58.0	6.1	6.2	5.8	6.0	5.9	5.6	4.4	4.1	3.9	3.6	3.4	3.3	2.8	2.7	2.7
62.0	5.0	5.6	5.7	4.9	5.5	5.2	4.0	3.7	3.5	3.2	3.0	2.9	2.3	2.3	2.4
66.0	4.1	4.4		3.9	4.5	4.7	3.6	3.3	3.2	2.8	2.6	2.6	1.9	1.9	2.0
70.0				3.1	3.5		3.1	3.0	2.9	2.4	2.3	2.3	1.5	1.6	1.7
74.0				2.0	2.5		2.4	2.8		2.1	2.0	2.0			
78.0							1.7	1.9		1.8	1.7	1.7			
82.0											1.5				

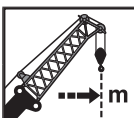

 m	40.4 m + 2.0 m + 29.5 m			45.4 m + 2.0 m + 29.5 m			50.5 m + 2.0 m + 29.5 m			55.6 m + 2.0 m + 29.5 m			60.0 m + 2.0 m + 29.5 m		
	0°	20°	40°	0°	20°	40°	0°	20°	40°	0°	20°	40°	0°	20°	40°
12.0	21.9														
14.0	20.4			18.9											
16.0	19.0			17.7			14.8			13.6					
18.0	17.8			16.7			13.7			12.5			11.9		
20.0	16.7			15.7			12.7			11.6			11.0		
22.0	15.8			14.9			11.9			10.7			10.2		
24.0	14.9	10.9		14.1	10.8		11.1			10.0			9.6		
26.0	14.1	10.4		13.4	10.3		10.5	8.2		9.4			9.0		
28.0	13.4	10.0		12.7	9.9		9.9	7.9		8.8	7.2		8.4		
30.0	12.8	9.6		12.1	9.5		9.3	7.5		8.3	6.9		7.9	6.6	
32.0	11.6	9.2	7.5	11.2	9.1	7.5	8.8	7.2		7.9	6.6		7.5	6.3	
34.0	10.3	8.8	7.3	9.9	8.8	7.3	8.3	6.9	6.0	7.5	6.3		7.1	5.9	
36.0	9.1	8.5	7.1	8.8	8.5	7.1	7.9	6.6	5.7	7.1	6.0	5.3	6.7	5.5	
38.0	7.9	8.2	6.9	7.8	8.2	6.9	7.5	6.3	5.5	6.7	5.7	5.1	6.4	5.2	4.4
40.0	6.9	7.9	6.8	6.7	7.9	6.7	6.8	6.1	5.4	6.4	5.5	4.9	5.9	4.9	4.2
42.0	5.9	7.7	6.6	5.8	7.6	6.5	5.9	5.9	5.2	6.0	5.2	4.7	5.4	4.6	4.0
44.0	5.1	6.7	6.4	5.0	6.6	6.4	5.1	5.7	5.0	5.2	5.0	4.6	4.8	4.3	3.8
46.0	4.4	5.8	6.3	4.2	5.8	6.3	4.3	5.5	4.9	4.5	4.8	4.4	4.2	4.1	3.6
48.0	3.7	5.0	6.1	3.6	5.0	6.1	3.6	5.1	4.7	3.9	4.7	4.2	3.5	3.9	3.4
50.0	3.1	4.3	5.3	2.9	4.3	5.3	3.0	4.4	4.6	3.3	4.4	4.1	3.0	3.6	3.3
54.0	2.0	3.0	3.8	1.9	3.0	3.8	1.9	3.1	4.0	2.2	3.4	3.8		3.2	3.0
58.0		1.9	2.4		1.9	2.6		2.0	2.8		2.3	3.1			2.7
62.0											2.0				

Tragfähigkeiten
Lifting capacities
Capacités de levage
Capacidades de elevación

98t

DIN/ISO/EN

	40.4 m + 2.0 m + 35.5 m			45.4 m + 2.0 m + 35.5 m			50.5 m + 2.0 m + 35.5 m			55.6 m + 2.0 m + 35.5 m			60.0 m + 2.0 m + 35.5 m		
	0°	20°	40°	0°	20°	40°	0°	20°	40°	0°	20°	40°	0°	20°	40°
14.0	17.2														
16.0	16.2			15.1											
18.0	15.3			14.3			12.9			11.0					
20.0	14.5			13.6			12.1			10.7			9.7		
22.0	13.7			12.9			11.3			9.9			9.5		
24.0	12.8			12.3			10.5			9.2			8.8		
26.0	12.0	8.5		11.7			9.9			8.6			8.2		
28.0	11.3	8.1		11.1	8.1		9.3			8.1			7.7		
30.0	10.7	7.8		10.6	7.7		8.7	6.9		7.6			7.3		
32.0	10.1	7.5		10.1	7.4		8.3	6.6		7.2	5.9		6.9	5.4	
34.0	9.6	7.1		9.7	7.1		7.8	6.3		6.8	5.6		6.5	5.0	
36.0	9.1	6.9	5.6	9.2	6.8		7.4	6.0		6.4	5.3		6.1	4.7	
38.0	8.7	6.6	5.4	8.8	6.6	5.4	7.1	5.7		6.1	5.1		5.8	4.4	
40.0	8.3	6.3	5.3	8.4	6.3	5.2	6.7	5.5	4.8	5.8	4.9		5.3	4.1	
42.0	7.9	6.1	5.1	8.1	6.1	5.1	6.4	5.3	4.6	5.5	4.7	4.1	4.9	3.9	3.3
44.0	7.6	5.9	5.0	7.7	5.9	4.9	6.1	5.1	4.5	5.2	4.5	3.9	4.5	3.6	3.1
46.0	7.3	5.7	4.8	7.4	5.7	4.8	5.8	4.9	4.3	4.8	4.3	3.7	4.1	3.4	2.9
48.0	7.0	5.5	4.7	7.1	5.5	4.7	5.4	4.7	4.2	4.5	4.0	3.5	3.7	3.2	2.7
50.0	6.7	5.3	4.6	6.8	5.4	4.6	5.1	4.6	4.0	4.1	3.8	3.3	3.4	3.0	2.6
54.0	6.2	5.0	4.4	6.2	5.0	4.4	4.5	4.1	3.7	3.6	3.4	3.0	2.8	2.6	2.3
58.0	5.8	4.8	4.3	5.6	4.8	4.2	3.9	3.6	3.4	3.0	2.9	2.7	2.3	2.3	2.0
62.0	5.2	4.5	4.1	5.0	4.5	4.1	3.5	3.2	3.0	2.6	2.5	2.4	1.9	1.9	1.8
66.0	4.2	4.3	4.1	4.1	4.1	3.9	3.1	2.8	2.7	2.2	2.1	2.1	1.5	1.6	1.6
70.0	3.4	3.9	4.0	3.2	3.8	3.6	2.7	2.5	2.4	1.9	1.8	1.8			
74.0	2.7	2.9		2.5	3.0	3.1	2.4	2.2	2.1	1.5	1.5	1.5			
78.0				1.8	2.1		1.9	2.0	1.9						
82.0								1.6							

MB + FJ

58t

DIN/ISO/EN

	40.4 m + 2.0 m + 35.5 m			45.4 m + 2.0 m + 35.5 m			50.5 m + 2.0 m + 35.5 m			55.6 m + 2.0 m + 35.5 m			60.0 m + 2.0 m + 35.5 m		
	0°	20°	40°	0°	20°	40°	0°	20°	40°	0°	20°	40°	0°	20°	40°
14.0	17.2														
16.0	16.2			15.1											
18.0	15.3			14.3			12.9			11.0					
20.0	14.5			13.6			12.1			10.7			9.7		
22.0	13.7			12.9			11.3			9.9			9.5		
24.0	12.8			12.3			10.5			9.2			8.8		
26.0	12.0	8.5		11.7			9.9			8.6			8.2		
28.0	11.3	8.1		11.1	8.1		9.3			8.1			7.7		
30.0	10.7	7.8		10.6	7.7		8.7	6.9		7.6			7.3		
32.0	10.1	7.5		10.1	7.4		8.3	6.6		7.2	5.9		6.9	5.4	
34.0	9.6	7.1		9.7	7.1		7.8	6.3		6.8	5.6		6.5	5.0	
36.0	9.1	6.9	5.6	9.2	6.8		7.4	6.0		6.4	5.3		6.1	4.7	
38.0	8.2	6.6	5.4	8.8	6.6	5.4	7.1	5.7		6.1	5.1		5.8	4.4	
40.0	7.1	6.3	5.3	8.4	6.3	5.2	6.7	5.5	4.8	5.8	4.9		5.3	4.1	
42.0	6.2	6.1	5.1	8.1	6.1	5.1	6.1	5.3	4.6	5.5	4.7	4.1	4.9	3.9	3.3
44.0	5.4	5.9	5.0	7.7	5.9	4.9	6.1	5.1	4.5	5.2	4.5	3.9	4.5	3.6	3.1
46.0	4.6	5.7	4.8	7.4	5.7	4.8	5.8	4.9	4.3	4.8	4.3	3.7	4.1	3.4	2.9
48.0	3.9	5.5	4.7	7.1	5.5	4.7	5.4	4.7	4.2	4.5	4.0	3.5	3.7	3.2	2.7
50.0	3.3	5.3	4.6	6.8	5.4	4.6	5.1	4.6	4.0	4.1	3.8	3.3	3.4	3.0	2.6
54.0	2.2	5.0	4.4	6.2	5.0	4.4	4.5	4.1	3.7	3.6	3.4	3.0	2.8	2.6	2.3
58.0		4.8	4.3	5.6	4.8	4.2	3.9	3.6	3.4	3.0	2.9	2.7	2.3	2.3	2.0
62.0		4.5	4.1	5.0	4.5	4.1	3.5	3.2	3.0	2.6	2.5	2.4	1.9	1.9	1.8

Tragfähigkeiten
Lifting capacities
Capacités de levage
Capacidades de elevación

98t

DIN/ISO/EN

m	40.4 m + 2.0 m + 41.5 m			45.4 m + 2.0 m + 41.5 m			50.5 m + 2.0 m + 41.5 m			55.6 m + 2.0 m + 41.5 m			60.0 m + 2.0 m + 41.5 m		
	0°	20°	40°	0°	20°	40°	0°	20°	40°	0°	20°	40°	0°	20°	40°
16.0	13.4			12.3											
18.0	12.7			11.7			10.5								
20.0	12.0			11.1			10.0			8.9					
22.0	11.3			10.5			9.6			8.6			7.9		
24.0	10.6			10.0			9.2			8.2			7.7		
26.0	10.0			9.5			8.8			7.8			7.4		
28.0	9.3			9.1			8.3			7.3			6.9		
30.0	8.8	6.2		8.7			7.8			6.8			6.5		
32.0	8.3	5.9		8.3	5.8		7.3			6.4			6.1		
34.0	7.8	5.6		7.9	5.6		6.9	5.4		6.0			5.6		
36.0	7.4	5.4		7.5	5.3		6.5	5.2		5.7	4.6		5.1	3.7	
38.0	7.0	5.1		7.1	5.1		6.2	4.9		5.3	4.3		4.7	3.4	
40.0	6.6	4.9		6.7	4.9		5.9	4.7		5.0	4.0		4.3	3.1	
42.0	6.3	4.7	3.8	6.4	4.7		5.5	4.4		4.6	3.7		3.9	2.9	
44.0	6.0	4.5	3.6	6.1	4.5	3.6	5.1	4.2		4.2	3.4		3.6	2.7	
46.0	5.7	4.3	3.5	5.8	4.3	3.5	4.8	3.9	3.2	3.8	3.2		3.3	2.5	
48.0	5.5	4.1	3.4	5.6	4.2	3.4	4.4	3.7	3.0	3.5	3.0	2.5	2.9	2.3	1.9
50.0	5.2	4.0	3.3	5.3	4.0	3.3	4.1	3.5	2.9	3.2	2.7	2.3	2.6	2.1	1.7
54.0	4.8	3.7	3.0	4.9	3.7	3.1	3.5	3.1	2.5	2.6	2.4	2.0	2.1	1.7	
58.0	4.4	3.4	2.8	4.5	3.5	2.9	3.0	2.7	2.3	2.1	2.0	1.7	1.6		
62.0	4.0	3.2	2.7	4.0	3.2	2.7	2.5	2.3	2.0	1.7	1.6				
66.0	3.7	3.0	2.5	3.5	3.0	2.5	2.1	1.9	1.8						
70.0	3.3	2.8	2.4	3.1	2.7	2.4	1.8	1.6	1.5						
74.0	2.6	2.6	2.4	2.3	2.4	2.3									
78.0	1.9	2.3		1.7	2.1	2.0									
82.0					1.5										

58t

DIN/ISO/EN

m	40.4 m + 2.0 m + 41.5 m			45.4 m + 2.0 m + 41.5 m			50.5 m + 2.0 m + 41.5 m			55.6 m + 2.0 m + 41.5 m			60.0 m + 2.0 m + 41.5 m		
	0°	20°	40°	0°	20°	40°	0°	20°	40°	0°	20°	40°	0°	20°	40°
16.0	13.4			12.3											
18.0	12.7			11.7			10.5								
20.0	12.0			11.1			10.0			8.9					
22.0	11.3			10.5			9.6			8.6			7.9		
24.0	10.6			10.0			9.2			8.2			7.7		
26.0	10.0			9.5			8.8			7.8			7.4		
28.0	9.3			9.1			8.3			7.3			6.9		
30.0	8.8	6.2		8.7			7.8			6.8			6.5		
32.0	8.3	5.9		8.3	5.8		7.3			6.4			6.1		
34.0	7.8	5.6		7.9	5.6		6.9	5.4		6.0			5.6		
36.0	7.4	5.4		7.5	5.3		6.5	5.2		5.7	4.6		5.1	3.7	
38.0	7.0	5.1		7.1	5.1		6.2	4.9		5.3	4.3		4.7	3.4	
40.0	6.6	4.9		6.6	4.9		5.9	4.7		5.0	4.0		4.3	3.1	
42.0	6.2	4.7	3.8	6.2	4.7		5.5	4.4		4.6	3.7		3.9	2.9	
44.0	5.4	4.5	3.6	5.0	4.5	3.6	4.9	4.2		4.2	3.4		3.6	2.7	
46.0	4.7	4.3	3.5	4.3	4.3	3.5	4.2	3.9	3.2	3.8	3.2		3.3	2.5	
48.0	4.0	4.1	3.4	3.7	4.2	3.4	3.6	3.7	3.0	3.4	3.0	2.5	2.9	2.3	1.9
50.0	3.4	4.0	3.3	3.1	4.0	3.3	3.0	3.5	2.9	2.9	2.7	2.3		2.1	1.7
54.0	2.3	3.7	3.0		3.7	3.1		3.1	2.5		2.4	2.0		1.7	
58.0		2.7	2.8		2.6	2.9		2.6	2.3			1.7			
62.0		1.7	2.7			2.7			2.0						

Tragfähigkeiten
Lifting capacities
Capacités de levage
Capacidades de elevación

m	40.4 m + 2.0 m + 47.5 m			45.4 m + 2.0 m + 47.5 m			50.5 m + 2.0 m + 47.5 m			55.6 m + 2.0 m + 47.5 m			60.0 m + 2.0 m + 47.5 m		
	0°	20°	40°	0°	20°	40°	0°	20°	40°	0°	20°	40°	0°	20°	40°
16.0	10.7														
18.0	10.1			9.3											
20.0	9.6			8.8			7.8								
22.0	9.0			8.3			7.5			6.5					
24.0	8.5			7.9			7.1			6.3			5.8		
26.0	8.1			7.5			6.8			6.0			5.6		
28.0	7.6			7.1			6.5			5.8			5.4		
30.0	7.2			6.8			6.2			5.6			5.2		
32.0	6.7			6.5			5.9			5.3			4.9		
34.0	6.3	4.4		6.2			5.6			5.1			4.7		
36.0	6.0	4.1		5.9	4.1		5.4			4.9			4.2		
38.0	5.6	3.9		5.6	3.9		5.2	3.8		4.6			3.8		
40.0	5.3	3.7		5.3	3.7		4.9	3.6		4.2	3.1		3.5	2.3	
42.0	5.0	3.5		5.1	3.5		4.7	3.5		3.8	2.8		3.1	2.1	
44.0	4.7	3.4		4.8	3.4		4.4	3.2		3.5	2.6		2.8	1.9	
46.0	4.5	3.2		4.6	3.2		4.0	3.0		3.2	2.4		2.5	1.7	
48.0	4.2	3.0	2.2	4.3	3.0		3.6	2.8		2.8	2.1		2.2	1.5	
50.0	4.0	2.9	2.0	4.1	2.9	2.0	3.3	2.6		2.5	1.9		2.0		
54.0	3.6	2.6	1.8	3.7	2.6	1.8	2.7	2.2	1.6	2.0	1.5		1.5		
58.0	3.3	2.3	1.6	3.4	2.4	1.6	2.2	1.9		1.5					
62.0	2.9	2.0	1.5	3.1	2.1	1.5	1.8	1.6							
66.0	2.6	1.8		2.6	1.9										
70.0	2.3	1.6		2.2	1.7										
74.0	2.0			1.8	1.5										
78.0	1.8			1.5											

MB+FJ

m	40.4 m + 2.0 m + 47.5 m			45.4 m + 2.0 m + 47.5 m			50.5 m + 2.0 m + 47.5 m			55.6 m + 2.0 m + 47.5 m			60.0 m + 2.0 m + 47.5 m		
	0°	20°	40°	0°	20°	40°	0°	20°	40°	0°	20°	40°	0°	20°	40°
16.0	10.7														
18.0	10.1			9.3											
20.0	9.6			8.8			7.8								
22.0	9.0			8.3			7.5			6.5					
24.0	8.5			7.9			7.1			6.3			5.8		
26.0	8.1			7.5			6.8			6.0			5.6		
28.0	7.6			7.1			6.5			5.8			5.4		
30.0	7.2			6.8			6.2			5.6			5.2		
32.0	6.7			6.5			5.9			5.3			4.9		
34.0	6.3	4.4		6.2			5.6			5.1			4.7		
36.0	6.0	4.1		5.9	4.1		5.4			4.9			4.2		
38.0	5.6	3.9		5.6	3.9		5.2	3.8		4.6			3.8		
40.0	5.3	3.7		5.3	3.7		4.9	3.6		4.2	3.1		3.5	2.3	
42.0	5.0	3.5		5.1	3.5		4.7	3.5		3.8	2.8		3.1	2.1	
44.0	4.7	3.4		4.8	3.4		4.4	3.2		3.5	2.6		2.8	1.9	
46.0	4.5	3.2		4.2	3.2		4.0	3.0		3.2	2.4		2.5	1.7	
48.0	3.9	3.0	2.2	3.5	3.0		3.4	2.8		2.8	2.1			1.5	
50.0	3.3	2.9	2.0	2.9	2.9	2.0	2.8	2.6			1.9				
54.0	2.2	2.6	1.8		2.6	1.8		2.2	1.6		1.5				
58.0		2.3	1.6		2.4	1.6									
62.0			1.5			1.5									

Hubhöhen
Lifting heights
Hauteurs de levage
Alturas de elevación

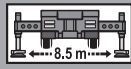
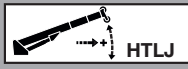
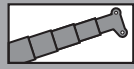

98t

DIN/ISO/EN

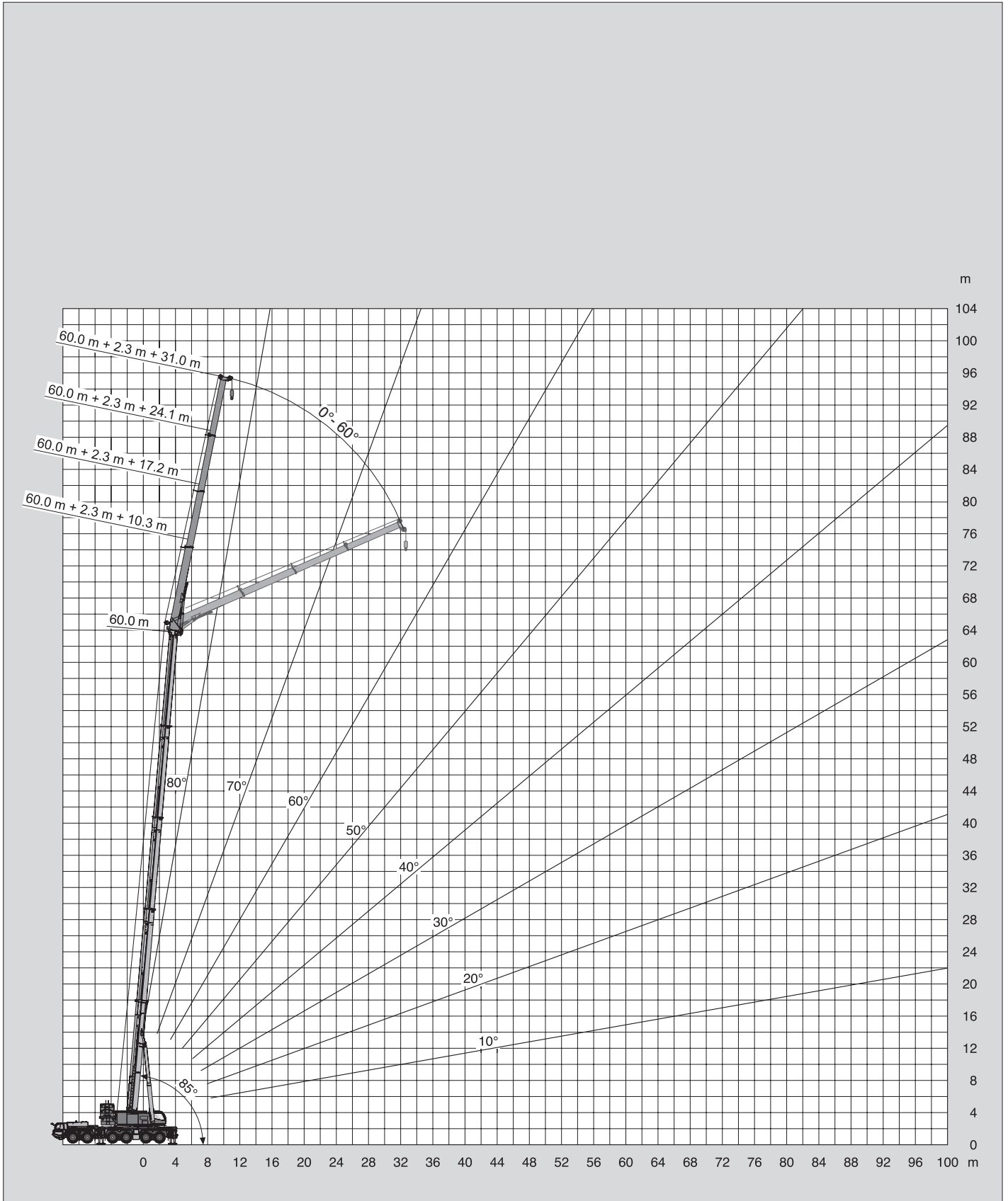

Tragfähigkeiten
Lifting capacities
Capacités de levage
Capacidades de elevación

98t

DIN/ISO/EN

m	40.4 m + 2.3 m + 10.3 m					40.4 m + 2.3 m + 17.2 m					40.4 m + 2.3 m + 24.1 m					40.4 m + 2.3 m + 31.0 m				
	5°	15°	30°	45°	60°	5°	15°	30°	45°	60°	5°	15°	30°	45°	60°	5°	15°	30°	45°	60°
9.0	38.4																			
10.0	36.0					16.7														
11.0	33.8	31.6				16.7														
12.0	31.9	30.2				16.7														
14.0	28.6	27.3	25.2			16.7	16.7				16.0									
16.0	25.8	24.8	23.5	22.1	21.1	16.7	16.7				15.5					10.9				
18.0	23.5	22.6	21.6	20.9	20.3	16.7	16.7	16.7			15.0	13.5				10.8				
20.0	21.5	20.8	19.9	19.4	19.0	16.7	16.7	15.9			14.5	13.0				10.5				
22.0	19.8	19.2	18.5	18.0	17.7	16.7	16.7	15.2	14.0		13.9	12.5				10.3	9.2			
24.0	18.3	17.8	17.2	16.8	16.5	16.7	16.2	14.5	13.4	12.9	13.4	12.1	10.8			10.0	8.8			
26.0	17.0	16.5	16.0	15.7	15.5	15.9	15.4	13.9	13.0	12.5	12.9	11.7	10.5			9.7	8.4			
28.0	15.8	15.4	15.0	14.7	14.6	14.8	14.4	13.3	12.5	12.1	12.5	11.4	10.1	9.3		9.2	8.1			
30.0	13.9	14.2	14.0	13.8		13.9	13.5	12.8	12.1	11.8	12.1	11.1	9.8	9.0	8.5	8.8	7.8	6.7		
32.0	12.1	12.4	12.7	12.9		13.0	12.6	12.2	11.8	11.6	11.7	10.8	9.5	8.8	8.4	8.5	7.5	6.4		
34.0	10.5	10.8	11.1	11.2		11.9	11.9	11.5	11.3	11.2	11.3	10.4	9.3	8.6	8.3	8.1	7.2	6.2		
36.0	9.1	9.4	9.6	9.7		10.5	10.9	10.9	10.7	10.6	10.9	10.0	9.0	8.5	8.2	7.8	6.9	6.1	5.5	
38.0	7.9	8.1	8.3	8.3		9.3	9.7	10.1	10.1		10.2	9.6	8.8	8.3	8.1	7.5	6.7	5.9	5.3	
40.0	6.7	6.9	7.1			8.2	8.5	9.0	9.2		9.1	9.3	8.5	8.1	8.0	7.2	6.5	5.7	5.2	5.0
42.0	5.7	5.9	6.0			7.1	7.5	7.9	8.1		8.1	8.5	8.2	7.9		7.0	6.3	5.5	5.1	5.0
44.0	4.8	4.9	5.0			6.2	6.5	6.9	7.0		7.2	7.6	8.0	7.7		6.7	6.1	5.4	5.0	4.9
46.0	3.9	4.0				5.3	5.6	5.9			6.3	6.8	7.3	7.4		6.5	5.9	5.3	4.9	4.8
48.0	3.1	3.2				4.6	4.8	5.0			5.6	6.0	6.5	6.7		6.3	5.7	5.1	4.8	
50.0						3.8	4.0	4.2			4.9	5.2	5.7	5.9		5.9	5.5	5.0	4.7	
54.0						2.5	2.7				3.6	3.9	4.2			4.6	5.0	4.8	4.6	
58.0											2.5	2.7	2.9			3.5	3.9	4.3		
62.0											1.5	1.6				2.5	2.8	3.1		
66.0																1.7	1.9			

MB + HTLJ

58t

DIN/ISO/EN

m	40.4 m + 2.3 m + 10.3 m					40.4 m + 2.3 m + 17.2 m					40.4 m + 2.3 m + 24.1 m					40.4 m + 2.3 m + 31.0 m				
	5°	15°	30°	45°	60°	5°	15°	30°	45°	60°	5°	15°	30°	45°	60°	5°	15°	30°	45°	60°
9.0	38.4																			
10.0	36.0					16.7														
11.0	33.8	31.6				16.7														
12.0	31.9	30.2				16.7														
14.0	28.6	27.3	25.2			16.7	16.7				16.0									
16.0	25.8	24.8	23.5	22.1	21.1	16.7	16.7				15.5					10.9				
18.0	23.5	22.6	21.6	20.9	20.3	16.7	16.7	16.7			15.0	13.5				10.8				
20.0	20.5	20.8	19.9	19.4	19.0	16.7	16.7	15.9			14.5	13.0				10.5				
22.0	16.8	17.9	18.5	18.0	17.7	16.7	16.7	15.2	14.0		13.9	12.5				10.3	9.2			
24.0	13.8	14.7	15.9	16.8	16.5	15.7	16.2	14.5	13.4	12.9	13.4	12.1	10.8			10.0	8.8			
26.0	11.3	12.1	13.1	13.8	14.2	13.2	14.5	13.9	13.0	12.5	12.9	11.7	10.5			9.7	8.4			
28.0	9.1	9.8	10.7	11.3	11.5	11.0	12.2	13.3	12.5	12.1	12.4	11.4	10.1	9.3		9.2	8.1			
30.0	7.2	7.9	8.6	9.1		9.2	10.2	11.7	12.1	11.8	10.6	11.1	9.8	9.0	8.5	8.8	7.8	6.7		
32.0	5.5	6.1	6.7	7.0		7.5	8.5	9.8	10.8	11.4	9.0	10.3	9.5	8.8	8.4	8.5	7.5	6.4		
34.0	4.0	4.5	5.0	5.2		6.1	7.0	8.1	9.0	9.4	7.5	8.8	9.3	8.6	8.3	8.1	7.2	6.2		
36.0	2.6	3.1	3.5	3.7		4.8	5.6	6.6	7.3	7.5	6.3	7.4	8.9	8.5	8.2	7.6	6.9	6.1	5.5	
38.0			2.2	2.3		3.6	4.3	5.2	5.8		5.1	6.2	7.5	8.3	8.1	6.4	6.7	5.9	5.3	
40.0						2.6	3.2	3.9	4.4		4.1	5.0	6.3	7.2	7.7	5.4	6.5	5.7	5.2	5.0
42.0							2.2	2.8	3.1		3.1	4.0	5.1	5.9		4.5	5.6	5.5	5.1	5.0
44.0											2.3	3.0	4.0	4.7		3.6	4.7	5.4	5.0	4.9
46.0												2.2	3.0	3.6		2.9	3.8	5.1	4.9	4.8
48.0													2.1	2.6			3.0	4.2	4.8	
50.0																	2.3	3.3	4.1	
54.0																			2.4	

Tragfähigkeiten
Lifting capacities
Capacités de levage
Capacidades de elevación



m	45.4 m + 2.3 m + 10.3 m					45.4 m + 2.3 m + 17.2 m					45.4 m + 2.3 m + 24.1 m					45.4 m + 2.3 m + 31.0 m					
	5°	15°	30°	45°	60°	5°	15°	30°	45°	60°	5°	15°	30°	45°	60°	5°	15°	30°	45°	60°	
10.0	29.3																				
11.0	27.6																				
12.0	26.1	24.4				16.7															
14.0	23.5	22.1	20.5			16.7					14.5										
16.0	21.3	20.2	18.8	17.9		16.7	16.7				14.5					10.2					
18.0	19.5	18.5	17.4	16.6	15.4	16.7	16.7				14.1				10.0						
20.0	17.9	17.1	16.1	15.5	15.1	16.4	15.4	14.3			13.7	12.5			9.8						
22.0	16.5	15.8	15.0	14.4	14.1	15.2	14.3	13.3			13.4	12.1			9.6	8.8					
24.0	15.3	14.7	14.0	13.5	13.2	14.1	13.3	12.5	11.9		13.0	11.7			9.4	8.4					
26.0	14.2	13.7	13.1	12.7	12.5	13.1	12.4	11.7	11.2	10.1	12.1	11.4	10.1		9.2	8.1					
28.0	13.3	12.8	12.3	12.0	11.8	12.2	11.6	11.0	10.5	9.9	11.3	10.7	9.8		8.9	7.8					
30.0	12.1	12.0	11.6	11.3	11.2	11.4	10.9	10.3	9.9	9.7	10.6	10.0	9.4	8.8	8.6	7.5	6.5				
32.0	10.8	10.8	10.7	10.6		10.7	10.2	9.7	9.4	9.2	9.9	9.4	8.9	8.5	7.3	8.2	7.3	6.3			
34.0	9.7	9.7	9.6	9.6		10.0	9.6	9.2	8.9	8.7	9.3	8.9	8.4	8.1	7.2	7.9	7.0	6.1			
36.0	8.3	8.6	8.7	8.6		9.1	9.1	8.7	8.4	8.3	8.8	8.4	7.9	7.7	7.1	7.6	6.8	5.9	5.4		
38.0	7.1	7.3	7.6	7.7		8.2	8.2	8.0	7.8	7.7	8.2	7.9	7.5	7.2	7.0	7.4	6.6	5.7	5.3		
40.0	5.9	6.2	6.4	6.5		7.4	7.4	7.4	7.3		7.5	7.2	6.9	6.7	6.5	7.1	6.4	5.6	5.1	4.9	
42.0	4.9	5.2	5.4			6.4	6.7	6.8	6.7		6.9	6.7	6.4	6.2	6.1	6.9	6.2	5.4	5.0	4.9	
44.0	4.0	4.2	4.4			5.5	5.8	6.1	6.1		6.2	6.2	5.9	5.8		6.3	6.0	5.3	4.9	4.8	
46.0	3.2	3.3	3.5			4.6	5.0	5.4	5.5		5.6	5.7	5.5	5.3		5.8	5.7	5.2	4.8	4.7	
48.0	2.4	2.5	2.6			3.8	4.2	4.5	4.6		4.9	5.2	5.1	4.9		5.4	5.2	5.0	4.7	4.7	
50.0	1.7	1.8				3.1	3.4	3.7			4.2	4.6	4.7	4.6		5.0	4.8	4.7	4.5		
54.0						1.9	2.1	2.2			2.9	3.3	3.7			3.9	4.1	4.0	3.9		
58.0											1.8	2.1	2.4			2.8	3.3	3.3	3.3		



m	45.4 m + 2.3 m + 10.3 m					45.4 m + 2.3 m + 17.2 m					45.4 m + 2.3 m + 24.1 m					45.4 m + 2.3 m + 31.0 m					
	5°	15°	30°	45°	60°	5°	15°	30°	45°	60°	5°	15°	30°	45°	60°	5°	15°	30°	45°	60°	
10.0	29.3																				
11.0	27.6																				
12.0	26.1	24.4				16.7															
14.0	23.5	22.1	20.5			16.7					14.5										
16.0	21.3	20.2	18.8	17.9		16.7	16.7				14.5				10.2						
18.0	19.5	18.5	17.4	16.6	15.4	16.7	16.7				14.1				10.0						
20.0	17.9	17.1	16.1	15.5	15.1	16.4	15.4	14.3			13.7	12.5			9.8						
22.0	16.3	15.8	15.0	14.4	14.1	15.2	14.3	13.3			13.4	12.1			9.6	8.8					
24.0	13.4	14.3	14.0	13.5	13.2	14.1	13.3	12.5	11.9		13.0	11.7			9.4	8.4					
26.0	10.9	11.7	12.8	12.7	12.5	12.7	12.4	11.7	11.2	10.1	12.1	11.4	10.1		9.2	8.1					
28.0	8.8	9.5	10.5	11.1	11.4	10.6	11.6	11.0	10.5	9.9	11.3	10.7	9.8		8.9	7.8					
30.0	7.0	7.6	8.4	9.0	9.2	8.8	9.9	10.3	9.9	9.7	10.1	10.0	9.4	8.8	8.6	7.5	6.5				
32.0	5.4	6.0	6.7	7.1		7.2	8.2	9.5	9.4	9.2	8.5	9.4	8.9	8.5	7.3	8.2	7.3	6.3			
34.0	4.0	4.5	5.1	5.5		5.8	6.7	7.9	8.8	8.7	7.1	8.4	8.4	8.1	7.2	7.9	7.0	6.1			
36.0		3.2	3.7	3.9		4.5	5.3	6.4	7.2	7.6	5.9	7.0	7.9	7.7	7.1	7.1	6.8	5.9	5.4		
38.0						3.4	4.1	5.1	5.8	6.0	4.8	5.8	7.3	7.2	7.0	6.0	6.6	5.7	5.3		
40.0							3.1	3.9	4.5		3.8	4.7	6.0	6.7	6.5	5.0	6.2	5.6	5.1	4.9	
42.0								2.8	3.3		2.8	3.7	4.9	5.9	6.1	4.1	5.2	5.4	5.0	4.9	
44.0												2.8	3.9	4.7		3.2	4.3	5.3	4.9	4.8	
46.0													3.0	3.7			3.5	4.8	4.8	4.7	
48.0														2.7			2.7	4.0	4.7	4.7	
50.0																	3.2	4.1			

Tragfähigkeiten
Lifting capacities
Capacités de levage
Capacidades de elevación







98t
DIN/ISO/EN

m	50.5 m + 2.3 m + 10.3 m					50.5 m + 2.3 m + 17.2 m					50.5 m + 2.3 m + 24.1 m					50.5 m + 2.3 m + 31.0 m				
	5°	15°	30°	45°	60°	5°	15°	30°	45°	60°	5°	15°	30°	45°	60°	5°	15°	30°	45°	60°
11.0	21.2																			
12.0	20.0																			
14.0	17.8	16.8				16.5														
16.0	16.0	15.2	14.2			15.0					13.0									
18.0	14.5	13.9	13.1	12.4	11.0	13.6	12.5				12.4					9.3				
20.0	13.2	12.7	12.1	11.6	10.7	12.4	11.7				11.5					9.3				
22.0	12.1	11.6	11.1	10.7	10.5	11.4	10.8	9.8			10.7	9.6				9.2				
24.0	11.1	10.7	10.3	9.9	9.7	10.5	10.0	9.2	8.5		9.9	9.0				9.0	8.3			
26.0	10.2	9.9	9.5	9.2	9.1	9.7	9.3	8.7	8.1	7.7	9.1	8.5	7.5			8.7	7.8			
28.0	9.3	9.0	8.7	8.5	8.3	8.9	8.6	8.2	7.7	7.4	8.4	8.0	7.1			8.2	7.4			
30.0	8.3	8.1	7.8	7.6	7.5	8.2	7.9	7.6	7.4	7.1	7.8	7.5	6.8			7.7	7.0			
32.0	7.4	7.2	7.0	6.9	6.7	7.3	7.1	6.9	6.7	6.6	7.1	6.9	6.4	6.0		7.2	6.6	5.9		
34.0	6.6	6.4	6.3	6.1		6.5	6.4	6.2	6.1	6.0	6.4	6.2	6.1	5.7	5.4	6.6	6.3	5.6		
36.0	5.8	5.7	5.6	5.5		5.9	5.7	5.6	5.5	5.4	5.7	5.6	5.5	5.4	5.2	5.9	5.8	5.3		
38.0	5.1	5.1	4.9	4.9		5.2	5.1	5.0	4.9	4.9	5.1	5.0	5.0	4.9	4.8	5.3	5.3	5.1	4.7	
40.0	4.5	4.5	4.4	4.3		4.6	4.6	4.5	4.4	4.4	4.6	4.5	4.5	4.4	4.4	4.8	4.8	4.7	4.5	
42.0	4.0	3.9	3.8	3.8		4.1	4.1	4.0	4.0		4.1	4.0	4.0	4.0	3.9	4.3	4.3	4.3	4.2	4.0
44.0	3.5	3.4	3.4	3.3		3.6	3.6	3.6	3.5		3.6	3.6	3.6	3.6	3.5	3.9	3.9	3.9	3.9	3.7
46.0	2.8	2.9	2.9			3.2	3.1	3.1	3.1		3.2	3.2	3.2	3.2		3.4	3.5	3.5	3.5	3.5
48.0	2.0	2.2	2.4			2.7	2.7	2.7	2.7		2.8	2.8	2.8	2.8		3.0	3.1	3.1	3.1	3.1
50.0		1.5	1.6			2.4	2.4	2.4	2.3		2.4	2.4	2.5	2.5		2.7	2.7	2.8	2.8	2.8
54.0						1.5	1.7	1.7			1.7	1.8	1.8	1.8		2.0	2.1	2.2	2.2	2.2
58.0																1.5	1.6	1.6	1.6	1.6

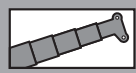
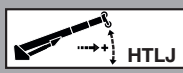
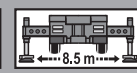
MB + HTLJ



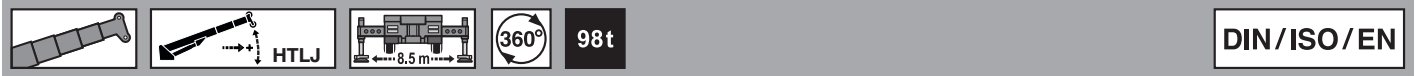

58t
DIN/ISO/EN

m	50.5 m + 2.3 m + 10.3 m					50.5 m + 2.3 m + 17.2 m					50.5 m + 2.3 m + 24.1 m					50.5 m + 2.3 m + 31.0 m				
	5°	15°	30°	45°	60°	5°	15°	30°	45°	60°	5°	15°	30°	45°	60°	5°	15°	30°	45°	60°
11.0	21.2																			
12.0	20.0																			
14.0	17.8	16.8				16.5														
16.0	16.0	15.2	14.2			15.0					13.0									
18.0	14.5	13.9	13.1	12.4	11.0	13.6	12.5				12.4					9.3				
20.0	13.2	12.7	12.1	11.6	10.7	12.4	11.7				11.5					9.3				
22.0	12.1	11.6	11.1	10.7	10.5	11.4	10.8	9.8			10.7	9.6				9.2				
24.0	11.1	10.7	10.3	9.9	9.7	10.5	10.0	9.2	8.5		9.9	9.0				9.0	8.3			
26.0	10.2	9.9	9.5	9.2	9.1	9.7	9.3	8.7	8.1	7.7	9.1	8.5	7.5			8.7	7.8			
28.0	8.8	9.0	8.7	8.5	8.3	8.9	8.6	8.2	7.7	7.4	8.4	8.0	7.1			8.2	7.4			
30.0	7.0	7.7	7.8	7.6	7.5	8.2	7.9	7.6	7.4	7.1	7.8	7.5	6.8			7.7	7.0			
32.0	5.4	6.0	6.8	6.9	6.7	7.1	7.1	6.9	6.7	6.6	7.1	6.9	6.4	6.0		7.2	6.6	5.9		
34.0	4.1	4.6	5.2	5.7		5.7	6.4	6.2	6.1	6.0	6.4	6.2	6.1	5.7	5.4	6.6	6.3	5.6		
36.0			3.9	4.2		4.5	5.3	5.6	5.5	5.4	5.7	5.6	5.5	5.4	5.2	5.9	5.8	5.3		
38.0						3.4	4.1	5.0	4.9	4.9	4.6	5.0	5.0	4.9	4.8	5.3	5.3	5.1	4.7	
40.0							3.1	4.0	4.4	4.4	3.6	4.5	4.5	4.4	4.4	4.8	4.8	4.7	4.5	
42.0									3.5					3.7	4.0	3.9	4.3	4.3	4.2	4.0
44.0														3.6	3.6	3.5	3.1	3.9	3.9	3.7
46.0														3.2			3.4	3.5	3.5	3.5
48.0																		3.1	3.1	3.1
50.0																		2.8	2.8	2.8

Tragfähigkeiten
Lifting capacities
Capacités de levage
Capacidades de elevación



m	55.6 m + 2.3 m + 10.3 m					55.6 m + 2.3 m + 17.2 m					55.6 m + 2.3 m + 24.1 m					55.6 m + 2.3 m + 31.0 m				
	5°	15°	30°	45°	60°	5°	15°	30°	45°	60°	5°	15°	30°	45°	60°	5°	15°	30°	45°	60°
12.0	16.1																			
14.0	15.6	14.5																		
16.0	13.9	13.2				12.7														
18.0	12.5	12.1	11.2			11.6	10.7				10.3									
20.0	11.3	11.0	10.4	9.9	8.5	10.7	9.8				10.1					6.9				
22.0	10.3	10.0	9.6	9.2	8.2	9.8	9.1	8.3			9.3	8.5				6.9				
24.0	9.3	9.1	8.8	8.6	8.0	8.9	8.5	7.8			8.6	7.9				6.9				
26.0	8.1	8.0	7.8	7.7	7.5	8.0	7.9	7.3	6.9		8.0	7.4				6.9	6.9			
28.0	7.0	6.9	6.8	6.7	6.6	7.0	6.9	6.8	6.5	6.2	7.3	6.9	6.3			6.9	6.4			
30.0	6.1	6.0	6.0	5.9	5.8	6.1	6.1	6.1	6.0	5.9	6.5	6.5	5.9			6.5	6.0			
32.0	5.2	5.2	5.2	5.1	5.0	5.3	5.3	5.3	5.3	5.3	5.7	5.7	5.6			5.8	5.6			
34.0	4.5	4.5	4.4	4.4	4.3	4.6	4.6	4.7	4.7	4.6	5.0	5.1	5.1	4.9		5.1	5.2	4.9		
36.0	3.8	3.8	3.8	3.7	3.7	3.9	4.0	4.1	4.1	4.0	4.4	4.5	4.6	4.5	4.3	4.5	4.6	4.5		
38.0	3.1	3.1	3.2	3.1		3.3	3.4	3.5	3.5	3.5	3.8	3.9	4.0	4.1	4.0	3.9	4.1	4.1		
40.0	2.5	2.6	2.6	2.6		2.8	2.9	3.0	3.0	3.0	3.2	3.4	3.5	3.6	3.6	3.4	3.6	3.7	3.5	
42.0	2.0	2.0	2.1	2.0		2.3	2.4	2.5	2.5	2.5	2.7	2.9	3.0	3.1	3.1	3.0	3.1	3.3	3.2	
44.0	1.5	1.5	1.6	1.6		1.8	1.9	2.0	2.1		2.3	2.4	2.6	2.7	2.7	2.5	2.7	2.9	2.9	2.8
46.0							1.5	1.6	1.6		1.9	2.0	2.2	2.3	2.3	2.1	2.3	2.5	2.6	2.6
48.0											1.5	1.6	1.8	1.9		1.7	1.9	2.1	2.3	2.3
50.0														1.5		1.6	1.8	1.9	2.0	2.0



m	55.6 m + 2.3 m + 10.3 m					55.6 m + 2.3 m + 17.2 m					55.6 m + 2.3 m + 24.1 m					55.6 m + 2.3 m + 31.0 m				
	5°	15°	30°	45°	60°	5°	15°	30°	45°	60°	5°	15°	30°	45°	60°	5°	15°	30°	45°	60°
12.0	16.1																			
14.0	15.6	14.5																		
16.0	13.9	13.2				12.7														
18.0	12.5	12.1	11.2			11.6	10.7				10.3									
20.0	11.3	11.0	10.4	9.9	8.5	10.7	9.8				10.1					6.9				
22.0	10.3	10.0	9.6	9.2	8.2	9.8	9.1	8.3			9.3	8.5				6.9				
24.0	9.3	9.1	8.8	8.6	8.0	8.9	8.5	7.8			8.6	7.9				6.9				
26.0	8.1	8.0	7.8	7.7	7.5	8.0	7.9	7.3	6.9		8.0	7.4				6.9	6.9			
28.0	7.0	6.9	6.8	6.7	6.6	7.0	6.9	6.8	6.5	6.2	7.3	6.9	6.3			6.9	6.4			
30.0	6.1	6.0	6.0	5.9	5.8	6.1	6.1	6.1	6.0	5.9	6.5	6.5	5.9			6.5	6.0			
32.0	5.2	5.2	5.2	5.1	5.0	5.3	5.3	5.3	5.3	5.3	5.7	5.7	5.6			5.8	5.6			
34.0	4.2	4.5	4.4	4.4	4.3	4.6	4.6	4.7	4.7	4.6	5.0	5.1	5.1	4.9		5.1	5.2	4.9		
36.0		3.5	3.8	3.7	3.7	3.9	4.0	4.1	4.1	4.0	4.4	4.5	4.6	4.5	4.3	4.5	4.6	4.5		
38.0							3.4	3.5	3.5	3.5	3.8	3.9	4.0	4.1	4.0	3.9	4.1	4.1		
40.0								3.0	3.0	3.0	3.2	3.4	3.5	3.6	3.6	3.4	3.6	3.7	3.5	
42.0									2.5	2.5		2.9	3.0	3.1	3.1	3.0	3.1	3.3	3.2	
44.0													2.6	2.7	2.7		2.7	2.9	2.9	2.8
46.0														2.3	2.3		2.3	2.5	2.6	2.6
48.0																		2.1	2.3	2.3
50.0																		1.9	2.0	2.0

Tragfähigkeiten
Lifting capacities
Capacités de levage
Capacidades de elevación

98t

DIN/ISO/EN

	60.0 m + 2.3 m + 10.3 m					60.0 m + 2.3 m + 17.2 m					60.0 m + 2.3 m + 24.1 m					60.0 m + 2.3 m + 31.0 m				
	5°	15°	30°	45°	60°	5°	15°	30°	45°	60°	5°	15°	30°	45°	60°	5°	15°	30°	45°	60°
14.0	13.2																			
16.0	12.8	12.3				8.8														
18.0	11.5	11.2	10.5			8.8					7.8									
20.0	10.4	10.1	9.7	9.2		8.8	8.8				7.8					6.2				
22.0	9.4	9.2	8.9	8.6	8.3	8.8	8.8				7.8					6.2				
24.0	8.2	8.1	8.0	7.9	7.7	8.5	8.2	7.5			7.8	7.4				6.2				
26.0	7.1	7.0	7.0	6.9	6.7	7.5	7.5	7.0			7.5	6.9				6.2				
28.0	6.1	6.1	6.0	6.0	5.9	6.5	6.5	6.5	6.2		6.6	6.5				6.2				
30.0	5.2	5.2	5.2	5.1	5.1	5.6	5.7	5.7	5.7	5.7	5.8	5.9	5.3			5.8	5.4			
32.0	4.4	4.4	4.4	4.4	4.3	4.9	4.9	5.0	5.0	5.0	5.0	5.1	4.9			5.1	4.9			
34.0	3.6	3.7	3.7	3.7	3.6	4.1	4.2	4.3	4.4	4.3	4.4	4.5	4.5	4.2		4.4	4.4			
36.0	3.0	3.0	3.1	3.1	3.0	3.5	3.6	3.7	3.8	3.7	3.7	3.9	4.1	3.9		3.8	4.0	3.6		
38.0	2.3	2.4	2.5	2.5		2.9	3.0	3.2	3.2	3.2	3.2	3.3	3.5	3.5	3.5	3.3	3.5	3.3		
40.0	1.8	1.8	1.9	1.9		2.3	2.5	2.6	2.7	2.7	2.6	2.8	3.0	3.2	3.2	2.8	3.0	3.0		
42.0						1.8	2.0	2.1	2.2	2.2	2.1	2.3	2.6	2.7	2.7	2.3	2.6	2.7	2.6	
44.0							1.5	1.7	1.8		1.7	1.9	2.1	2.3	2.3	1.9	2.2	2.5	2.4	
46.0												1.5	1.7	1.9	1.9	1.5	1.8	2.1	2.2	2.2
48.0													1.5	1.5			1.7	1.9	2.0	2.0
50.0																		1.6	1.6	1.6

58t

DIN/ISO/EN

	60.0 m + 2.3 m + 10.3 m					60.0 m + 2.3 m + 17.2 m					60.0 m + 2.3 m + 24.1 m					60.0 m + 2.3 m + 31.0 m				
	5°	15°	30°	45°	60°	5°	15°	30°	45°	60°	5°	15°	30°	45°	60°	5°	15°	30°	45°	60°
14.0	13.2																			
16.0	12.8	12.3				8.8														
18.0	11.5	11.2	10.5			8.8					7.8									
20.0	10.4	10.1	9.7	9.2		8.8	8.8				7.8					6.2				
22.0	9.4	9.2	8.9	8.6	8.3	8.8	8.8				7.8					6.2				
24.0	8.2	8.1	8.0	7.9	7.7	8.5	8.2	7.5			7.8	7.4				6.2				
26.0	7.1	7.0	7.0	6.9	6.7	7.5	7.5	7.0			7.5	6.9				6.2				
28.0	5.6	6.1	6.0	6.0	5.9	6.5	6.5	6.5	6.2		6.6	6.5				6.2				
30.0			5.2	5.1	5.1	5.6	5.7	5.7	5.7	5.7	5.8	5.9	5.3			5.8	5.4			
32.0							4.9	5.0	5.0	5.0	5.0	5.1	4.9			5.1	4.9			
34.0								4.3	4.4	4.3		4.5	4.5	4.2		4.4	4.4			
36.0									3.8	3.7			4.1	3.9		4.0	3.6			
38.0													3.5	3.5	3.5		3.5	3.3		
40.0														3.2	3.2		3.0	3.0		
42.0															2.7		2.7	2.6		
44.0																	2.4	2.4		
46.0																				2.2

MB+HTLJ

Anmerkungen zu den Traglasttabellen Remarks relating to the rating charts Remarques relatives aux tableaux des charges Notas relativas a los graficos de carga

Anmerkungen zu den Traglasttabellen

Die Tragfähigkeiten im Festigkeitsbereich basieren auf DIN 15018 Blatt 2 und Blatt 3 und F.E.M.

Die Tragfähigkeiten im Standsicherheitsbereich entsprechen DIN 15019 Teil 2 / ISO 4305 / EN 13000.

In Abhängigkeit der Auslegerlänge sind bei den Traglasttabellen Windgeschwindigkeiten von max. 10 m/s am Teleskopausleger und max. 7 m/s mit der Auslegerverlängerung zulässig.

Die Tragfähigkeiten sind in metrischen Tonnen angegeben.



Das Gewicht des Lasthakens bzw. der Hakenflasche und weiterer Anschlagmittel ist von der Tragfähigkeit abzuziehen.

Die Tragfähigkeiten für den Teleskopausleger gelten nur bei demontierter Auslegerverlängerung.

Die Ausladung ist der horizontale Abstand von Mitte Drehkranz bis Mitte freihängender, nicht schwingender Last.

Für Lasten über 157 t Zusatzrollen im Rollenkopf erforderlich.

Für bestimmte Lastfälle ist der Einsatz der 2. Hubwinde erforderlich.

	MB	25,1 m	30,2 m	35,3 m
	max. t	> 154,4	> 131,4	> 108,1

Tragfähigkeitsänderungen vorbehalten.

Obige Angaben dienen nur zur Information. Die Bedienungsanleitungen müssen zu Rate gezogen werden, bevor die Maschine in Betrieb genommen wird. Alle hier gemachten Angaben beziehen sich auf die Standard-Ausführung. Jegliche Ausrüstungsveränderungen können die angegebenen Werte beeinflussen.

Remarks relating to the rating charts

The lifting capacities in the structural area are based on DIN 15018 parts 2 and 3 and F.E.M.

The lifting capacities in the stability area are based on DIN 15019 part 2 / ISO 4305 / EN 13000.

Maximum admissible wind velocity for working with telescopic boom is 10 m/sec to 7 m/sec depending at boom length and for working with boom extension 7 m/sec.

The lifting capacities are shown in metric tons.



The weight of load handling devices such as hook blocks, slings, etc., must be considered as part of the load and must be deducted from the lifting capacities.

The lifting capacities for the telescopic boom apply to a crane with no boom extensions being stowed or mounted on the crane.

The working radius is the horizontal distance from the centre of rotation to the centre of the freely suspended non-oscillating load.

Additional sheaves for boom head essential for loads bigger than 157 t.

2. Winch is essential for particular loads.

	MB	25.1 m	30.2 m	35.3 m
	max. t	> 154.4	> 131.4	> 108.1

The lifting capacities are subject to change without prior notice.

The above remarks are for basic information only and the operator's manual must be consulted before operating this crane. All data and performances refer to the standard crane. The addition of optional and other equipment may affect the performance of the crane.

Remarques relatives aux tableaux des charges

Les forces de levage sont conformes aux normes DIN 15018, p. 2 et 3, et F.E.M.

Les forces de levage dans la partie de stabilité au renversement sont conformes aux normes DIN 15019, chap. 2 / ISO 4305 / EN 13000.

Des vitesses de vent sont admissibles entre 7 m/s jusqu'à max 10 m/s en fonction de la longueur de flèche.

Les forces de levage sont données en tonnes métriques.



Le poids du crochet-moufle et de tous les accessoires d'élingage font partie de la charge et sont à déduire des charges indiquées.

Les forces de levage indiquées pour la flèche télescopique s'entendent flèche déposée.

Comme portée, on entend la distance horizontale du centre de la couronne de rotation au centre de la charge librement suspendue et non oscillante.

Pour des charges supérieures à 157 t, des poulies supplémentaires sont nécessaires sur la tête de flèche.

Un 2^{ème} treuil est nécessaire pour les levages spéciaux.

	MB	25,1 m	30,2 m	35,3 m
	max. t	> 154,4	> 131,4	> 108,1

Sauf modification de forces de levage.

Les données ci-dessus servent à titre d'information. Avant la mise en marche de la grue il est conseillé d'étudier les instructions de service. Toutes les données indiquées ci-dessus se réfèrent à la machine de base. Tout changement de l'équipement de la grue peut influencer ces valeurs.

Notas relativas a los graficos de carga

En cuanto a los datos referentes a resistencia, las capacidades de carga están basados sobre las normas DIN 15018, pág. 2 y 3, y F.E.M.

En cuanto a los datos referentes a estabilidad anti-vuelco, las capacidades de carga están basados sobre las normas DIN 15019, Cap. 2 / ISO 4305 / EN 13000.

En independencia a la longitud de la pluma, están toleradas velocidades de viento de entre 7 m/s y 10 m/s.

Las capacidades de carga indicadas en las tablas corresponden a toneladas métricas.



Hay que deducir los pesos del gancho, eslingas y de otros dispositivos para fijación de cargas de los valores indicados en las tablas.

Las capacidades de carga referentes a la pluma telescópica valen solamente si el plumin está desmontada.

Como alcance se entiende la distancia horizontal desde el centro de la corona de giro hasta el centro de la carga suspendida libremente y no oscilante.

Para cargar superiores a 157 t / es necesario poleas adicionales en cabeza de pluma.

Para posibles trabajos es necesario el montaje del 2º cabestrante.

	MB	25,1 m	30,2 m	35,3 m
	max. t	> 154,4	> 131,4	> 108,1

Salvo modificación de capacidades de carga, sin previo aviso.

Los datos arriba indicados sirven solamente para su información. Hay que leer las instrucciones para el uso antes de la puesta en servicio de la máquina. Todos los datos mencionados en las presentes tablas rigen para los modelos standard. Cualquier modificación del equipo montado puede dar lugar a modificaciones de aquellos valores.

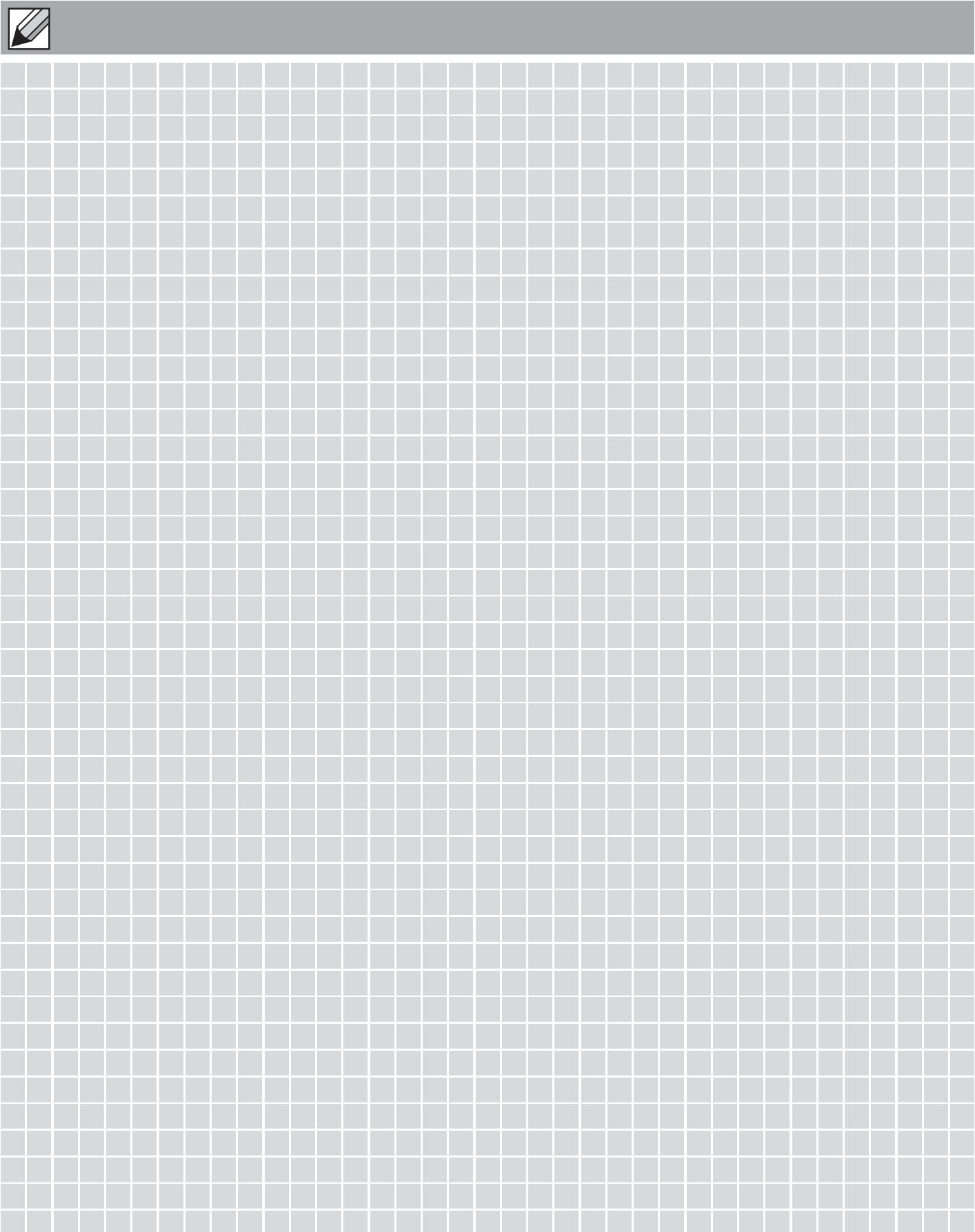
 A large rectangular area filled with a light grey grid pattern, intended for taking notes. It is positioned below a grey horizontal bar that contains a pencil icon.

Ausrüstung



Rahmen Verwindungs- und biegesteife Schweißkonstruktion aus hochfestem Feinkornstahl. Zentralschmieranlage.

Abstützung 4-Punkt-Abstützung, hydraulisch, Bedienungsmöglichkeiten an beiden Seiten des Fahrgestelles und in der Oberwagenkabine.
Abstützbasis 8,5 m (und 8,0 m, 6,8 m, 5,5 m) x 8,9 m.

Motor Mercedes-Benz 8-Zylinder-Dieselmotor OM 502 LA (Euromot III B), wassergekühlt, Leistung 480 kW (653 PS) bei 1800 min⁻¹.
Drehmoment 3000 Nm (306 kpm) bei 1300 min⁻¹.
Motorleistung nach 80 / 1269 / EWG. Kraftstoffbehälter 450 l. AdBlue-Behälter 40 l.

Getriebe ZF-TC-Tronic "Heavy Duty", mechanisches Schaltgetriebe mit Wandlerschaltkupplung und integriertem Intarder, elektronisch-pneumatisch betätigter Trockenkupplung und vollautomatischer Schaltung mit 12 Vorwärts- und 2 Rückwärtsgängen. Power and Economy Modus wählbar.

Antrieb 12 x 8 x 12

Achsen

1. Achse: gelenkt, angetrieben, Differentialsperre quer.
2. Achse: gelenkt, nicht angetrieben.
3. Achse: gelenkt, angetrieben, Differentialsperre längs und quer.
4. Achse: gelenkt, angetrieben, Differentialsperre quer.
5. Achse: gelenkt, angetrieben, Differentialsperre quer.
6. Achse: gelenkt, nicht angetrieben.

Achsaufhängung Hydropneumatische Federung mit Niveauregulierung.

Bremsen Druckluft-Zweikreis-Scheibenbremsanlage. Feststellbremse als Federspeicherbremse an der 3., 4., 5. und 6. Achse wirkend. Intarder mit Bremsomat-Funktion und Konstantdrosselanlage mit Auspuffklappenbremse als Dauerbremse.

Räder 12-fach 445/95 R 25 (16.00 R 25), Breite 3 m.

Lenkung ZF-Servocom-Zweikreis-Hydraulenlenkung mit Notlenkpumpe. Mechanische Lenkung der 1. und 2. Achse.
Im Betriebsmodus "Straße" werden die Achsen 3-6 bis zu einer Geschwindigkeit von 30 km/h elektronisch mitgelenkt.
Ab einer Geschwindigkeit von 30 km/h werden die Achsen 4 und 5 in in Geradeausposition verriegelt und ab einer Geschwindigkeit von 50 km/h zusätzlich die Achsen 3 und 6.

Unterswagenkabine Zwei-Mann-Frontfahrerhaus in Stahl-Kunststoff-Verbund-Konstruktion, Sicherheitsverglasung, luftgefederte Sitze (Fahrersitz mit Heizung) und motorabhängige Warmwasserheizung, Klimaanlage, Radio-CD-Player, Kontroll- und Bedienungselemente für den Fahrbetrieb, Tempomat- / Bremsomat-Funktion.

Elektrische Anlage 24 Volt-Gleichstrom, 2 Batterien, Verdrahtung mit CAN-Bus-Komponenten, integrierte Eigendiagnose Faun-CSS-System, Abstützbeleuchtung.
Die elektrische Anlage entspricht der EG-Norm.

Zusatzausrüstung (gegen Mehrpreis)
Anhängekupplung, motorunabhängige Zusatzheizung mit Motorvorwärmung, ABS, 525/80 R 25 (20.5 R 25) Bereifung / Breite 3,2 m, Reserverad, Sonderlackierung und Beschriftung.
Weitere Zusatzausrüstung auf Anfrage.

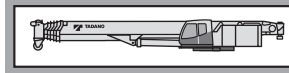

Rahmen Verwindungssteife Schweißkonstruktion mit einer außenverzahnten, dreireihigen Rollendrehverbindung, um 360° unbegrenzt drehbar. Zentralschmieranlage.

Motor Mercedes-Benz 6-Zylinder-Dieselmotor OM 926 LA (Euromot III B), wassergekühlt. Drehzahl ist über Fußpedal stufenlos regelbar, Leistung 195 kW (265 PS) bei 2200 min⁻¹.
Drehmoment 1100 Nm (112 kpm) bei 1200 - 1600 min⁻¹,
Motorleistung nach DIN 6270B / DIN 6271.
Kraftstoffbehälter 230 l. AdBlue-Behälter: 8 l.

Hydraulik System Diesel-hydraulisch mit 3-Kreis-Hydraulik, 1 leistungsgeregelte Axialkolben-Doppelpumpe (hydraulisch verstellbar), 1 Axialkolbenpumpe und 1 Zahnradpumpe, Ölkühler.

Steuerung Zwei 4-fach Kreuzsteuerhebel mit elektrischer Vorsteuerung.

Teleskopausleger Fünfteiliger Teleskopausleger aus hochfestem Feinkornstahl, bestehend aus einem Grundaussleger und 4 Teleskopteilen, 1 Teleskopzylinder, hydraulisch unter Teillast teleskopierbar. 15,0 m - 60,0 m lang. Rollenkopf mit 7 Seilrollen.

Wippwerk Ein Differentialzylinder mit angebautem Senkbremssperrventil.

Hubwerk Axialkolben-Verstell-Motor, Hubwerkstrommel mit eingebautem Planetengetriebe und federbelasteter Hydro-Lamellenbremse mit integriertem Freilauf beim Heben. Hubseil mit 'Super-Stop' Einrichtung.

Drehwerk Axialkolben-Motor, dreistufiges Planetengetriebe mit automatischer Betriebs- und Feststellbremse. Offener Hydraulikkreislauf mit Drehwerk-Freischtaltung.
Drehgeschwindigkeit stufenlos von 0 - 1,1 min⁻¹.

Gegengewicht Gesamtgewicht 98 t teilbar.
Die Bedienung erfolgt mittels einer Fernbedieneinheit.

Oberwagenkabine Großräumige Krankkabine in Stahl-Kunststoffausführung mit Sicherheitsverglasung und getönten Scheiben, kippbarem Arbeitsplatz mit verstellbarem, hydraulisch gedämpftem Fahrersitz mit Heizung, motorabhängige und motorunabhängige Warmwasserheizung (mit Motorvorwärmung), Klimaanlage, Radio-CD-Player, Kontroll- und Bedienungselemente sowie graphische LCD-Anzeige für Kranbetrieb.

Elektrische Anlage 24 Volt-Gleichstrom, 2 Batterien.

Sicherheitseinrichtungen 'Lift- und 'Release Adjuster' (automatische Überwachung des Arbeitsradius in Folge Auslegerverformung durch Lasteinwirkung), Lastmomentbegrenzung (LMB), Windmesser, Arbeitsbereichsbegrenzung, Hubendschalter, Windenendschalter, Seilwindendrehmelder, Sicherheitsventile gegen Rohr- und Schlauchbrüche. Sperrventile an Hydraulik-Zylindern.

Zusatzausrüstung (gegen Mehrpreis)
Auslegerverlängerungen: Light fixed jib 6,0 m - 24,0 m, Fixed jib 13,5 m - 49,5 m, HTLJ 10,3 m - 31,0 m, Unterflaschen von 12,5 t bis 250 t, Zusatzgegengewicht 20 t / 40 t, 2. Hubwerk, Zusatzölkühler, Sonderlackierung und Beschriftung.
Weitere Zusatzausrüstung auf Anfrage.

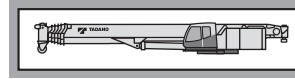
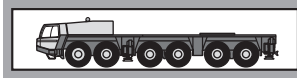

Frame Torsion resistant, welded construction made from high strength, fine-grained steel. Central lubricating system.

Outriggers 4 point, double telescopic hydraulic outriggers with controls on both sides of carrier and in superstructure cab. Outrigger base 8.5 m (8.0 m, 6.8 m, 5.5 m mid extension) x 8.9 m.

Carrier engine Mercedes-Benz 8 cylinder model OM 502 LA (Euromot III B), water-cooled diesel engine. Rated at 480 kW (653 HP) at 1800 min⁻¹. Torque 3000 Nm (306 kpm) at 1300 min⁻¹. Engine rating according to 80 / 1269 / EWG. Fuel tank 450 l. AdBlue-tank 40 l.

Transmission ZF-TC-Tronic HD transmission in "heavy duty" version with torque converter and integrated interarder, electro-pneumatically operated dry-type clutch and automatic gear shifting with 12 forward gears and 2 reverse gears. Power / Economy mode.

Drive 12 x 8 x 12

Axles

1st axle: steered, driven.
2nd axle: steered, not driven.
3rd axle: steered, driven, with longitudinal differential lock.
4th axle: steered, driven.
5th axle: steered, driven.
6th axle: steered, not driven.
All driven axles with transverse differential locks.

Suspension Hydro-pneumatic with levelling adjustment.

Brake system Service disc brakes: dual circuit compressed air system. Parking brake: spring loaded type acting on 3rd, 4th, 5th and 6th axles. Auxiliary brakes: interarder with 'Bremsomat' function, engine exhaust brake and constant throttle engine brake system.

Tyres (12) 445/95 R 25 (16.00 R 25), width 3 m.

Steering system ZF-Servocom, dual circuit hydraulic steering with emergency steering pump, mechanical hydraulically-assisted steering of front two axles. On road mode the 1st and 2nd axle are permanently steered and mechanically connected to the steering gear unit and the 3rd, 4th, 5th and 6th axle are automatically steered, electro-hydraulically, with the 1st and 2nd axles up to a travel speed of 30 km/h and 50 km/h respectively. At a speed of 30 km/h, the 4th and 5th axles are automatically locked in the straight ahead position. At a speed of 50 km/h, the 3rd and 6th axle is automatically locked in the straight ahead position.

Carrier cab Two man full width cab of composite (steel sheet metal and fibre-glass) structure, with safety glass, air-cushioned adjustable seats (driver seat with heater) and engine dependent hot-water heater, air conditioning, radio-CD-player, complete controls and instrumentation for road travel. 'Tempomat- / Bremsomat' function.

Electrical system 24 volt DC system, 2 batteries, CAN-Bus system with Faun CSS integrated self-diagnosis system, outrigger lighting. Electrical system conforms with EEC regulations.

Optional Equipment (at extra charge)

Towing attachment, engine independent additional heater with engine pre-heat, ABS, 525/80 R 25 (20.5 R 25) tyres / width 3.2 m, spare wheel and tyre, special painting and lettering. Further optional equipment available upon request.

Frame Torsion-resistant, all-welded structure of high strength steel. Connected to carrier by triple roller bearing slewing ring with external gearing for 360° continuous rotation. Central lubricating system.

Superstructure engine Mercedes-Benz 6 cylinder model OM 926 LA (Euromot III B), water cooled, diesel engine. PRM infinitely variable via foot pedal, rating 195 kW (265 HP) at 2200 min⁻¹. Torque 1100 Nm (112 kpm) at 1200 - 1600 min⁻¹. Engine rating according to DIN 6270B / DIN 6271. Fuel tank 230 l. AdBlue-tank 8 l.

Hydraulic system Three circuit diesel hydraulic system with 1 power controlled axial piston double pump (hydraulically adjustable) 1 axial piston pump and 1 gear pump, oil cooler.

Controls Electrical, 2 joy-stick levers for simultaneous operation of crane motions.

Telescopic boom 5 sections, made of high tensile, fine-grained steel, consisting of 1 base section and 4 telescoping sections extended by means of a single telescopic cylinder. All telescope sections extendable under partial load. 15.0 m to 60.0 m long. Boom head with 7 sheaves.

Derricking system 1 double acting hydraulic cylinder with integral brake and holding valve.

Main winch Axial piston variable displacement motor, winch drum with integrated planetary reduction and with hydraulically controlled spring-loaded, multiple disc brake. Hoist cable with 'Super-Stop' easy reeving system.

Slewing system Axial piston motor with three-stage planetary gear with automatic service and a parking brake. Open hydraulic circuit with free slewing function. Speed infinitely variable 0 - 1.1 min⁻¹.

Counterweight Total 98 t divisible, assembled and disassembled by hydraulic cylinders operated by remote control.

Superstructure cab Spacious panoramic cab of composite structure with safety (tinted) glass windows, tiltable cockpit with hydraulically cushioned adjustable seat with heater, one engine dependent hot-water heater and one engine independent hot-water heater (with engine pre-heat), air conditioning, radio-CD-player. Complete controls and instrumentation plus LCD graphic display for crane operation.

Electrical system 24 volt DC system, 2 batteries.

Safety devices 'Lift- and Release Adjuster', (automatic radius correction based on boom deflection under load) load moment device (LMD), anemometer, working area limitation, hoist limit switch, lower limit switch and drum turn indicator, safety valves against pipe and hose rupture, holding valves on hydraulic cylinders.

Optional Equipment (at extra charge)

Boom extensions: Light fixed jib 6.0 m - 24.0 m, Fixed jib 13.5 m - 49.5 m, HTLJ 10.3 m - 31.0 m, hook blocks 12.5 t - 250 t, additional counterweight 20 t / 40 t, auxiliary winch, additional oil cooler, special painting and lettering.

Further optional equipment available upon request.

Equipement



Châssis Construction mécanosoudé, en acier à grain fin très rigide, résistant aux flexions et aux torsions. Graissage centralisé.

Calage Dispositif de calage horizontal et vertical en 4 points, entièrement déployable hydrauliquement. Commande des mouvements sur les deux côtés du porteur et depuis la cabine de la superstructure.

Calage 8,5 m (8,0 m, 6,8 m, 5,5 m à mi-extension) x 8,9 m.

Moteur Mercedes Benz diesel 8 cylindres, modèle OM 502 LA (Euromot III B), refroidi par eau, de 480 kW (653 CV) à 1800 min⁻¹. Couple: 3000 Nm (275 kpm) à 1300 min⁻¹. Puissance selon 80 / 1269 / EWG. Capacité du réservoir 450 l. AdBlue-capacité du réservoir 40 l.

Boîte de vitesse Boîte de vitesse ZF-TC-Tronic "Heavy Duty". Boîte mécanique avec convertisseur et Intarder intégré, avec embrayage électro-pneumatique à commande automatique, 12 vitesses AV et 2 vitesses AR. Mode max. performance / économique.

Entraînement 12 x 8 x 12

Essieux

1^{er} essieu: directeur, entraîné, blocage de différentiel transversal.

2^{ième} essieu: directeur, non entraîné.

3^{ième} essieu: directeur, entraîné, blocage de différentiel longitudinal et transversal.

4^{ième} essieu: directeur, entraîné, blocage de différentiel transversal.

5^{ième} essieu: directeur, entraîné, blocage de différentiel transversal.

6^{ième} essieu: directeur, non entraîné.

Suspension Hydro-pneumatique, avec réglage de niveau.

Freins Freins de service à disque: système à double circuit d'air comprimé. Frein destination: avec accumulateurs à ressort agissant sur le 3^{ième}, 4^{ième}, 5^{ième} et 6^{ième} essieu. Freins continus: frein moteur par clapet sur échappement. Ralentisseur hydrodynamique Intarder.

Pneus 12 x 445/95 R 25 (16.00 R 25), largeur 3 m.

Direction Servocom à double circuit, marque ZF avec pompe de direction auxiliaire. Direction mécanique du 1^{er} et 2^{ième} essieu. En mode "route" les essieux 3 - 6 sont directionnels jusqu'à une vitesse de 30 km/h. A partir d'une vitesse de 30 km/h les essieux 4 et 5 sont verrouillés dans une droite et position à partir de 50 km/h les essieux 3 et 6 sont aussi verrouillés.

Cabine Cabine bi-place, construction en matière composite fibre de verre et acier. Vitrage en verre de sécurité, siège conducteur chauffant suspendu hydrauliquement. Chauffage à eau chaude relié au moteur, climatisation, radio-CD-player. Organes de contrôle et de commande pour la conduite. Régulateur de vitesse, système automatique de freinage.

Système électrique 24 V courant continu, 2 batteries, connexion circuit électrique avec CAN-Bus. Équipement avec prise diagnostic et avec interprétation de code erreur de système FAUN CSS, éclairage des points de calage. Conforme aux normes CE.

Équipement supplémentaire (avec supplément de prix)

Attache-remorque, chauffage auxiliaire indépendant du moteur avec préchauffage du moteur, ABS, pneus 525/80 R 25 (20.5 R 25) / largeur 3,2 m, roue de secours, peinture spéciale et inscription.

Autres équipements supplémentaires sur demande.

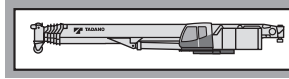

Plate forme Construction mécano-soudée résistante à la torsion. Couronne d'orientation à triple rangée de rouleaux avec denture extérieure pour une rotation à 360° en continu. Graissage centralisé.

Moteur Mercedes Benz diesel 6 cylindres, modèle OM 926 LA (Euromot III B), refroidi par eau.

Réglage du nombre de tours par pédale, de 195 kW (265 CV) à 2200 min⁻¹. Couple: 1100 Nm (112 kpm) à 1200 - 1600 min⁻¹.

Puissance selon DIN 6270B / DIN 6271.

Capacité du réservoir 230 l.

AdBlue-capacité du réservoir 8 l

Système hydraulique Diesel-hydraulique à 3 circuits, 1 double pompe à pistons axiaux à régulation de puissance (à réglage hydraulique) 1 pompe à pistons axiaux et 1 pompe à engreages, refroidisseur d'huile.

Commande 2 manipulateurs à commande en croix (4 sens), assistés électriquement.

Flèche télescopique 1 flèche de base et 4 éléments télescopiques en acier fin, 1 vérin télescopique, hydrauliquement télescopable avec charge partielle. Longueur de 15,0 m à 60,0 m. Tête de flèche avec 7 poulies.

Mécanisme de relevage 1 vérin différentiel muni de clapet de freinage de descente.

Mécanisme de levage Moteur hydraulique à cylindrée variable, tambour de levage avec boîte planétaire incorporée, frein d'arrêt à disques multiples à ressort, libéré lors du levage. Câble de levage avec dispositif 'Super-Stop'.

Orientation Moteur hydraulique avec entraînement planétaire à 3 gammes avec frein de stationnement automatique. Circuit ouvert avec déconnexion de l'orientation.

Vitesse de rotation 0 à 1,1 min⁻¹ en continu.

Contrepoids Poids total 98 t divisible, assembles et démantelés grâce à des vérins hydrauliques télécommandés.

Cabine du grutier Cabine de grue spacieuse, construction en matière combinée acier / synthétique, avec vitrage de sécurité en verre teinté, siège chauffant, réglable et amorti hydrauliquement, inclinable avec instruments de commande, chauffage à eau chaude dépendant et indépendant du moteur (avec préchauffage du moteur), climatisation, radio-CD-player, éléments de commande et de contrôle avec affichage digital pour travaux.

Système électrique 24 V courant continu, 2 batteries.

Dispositifs de sécurité 'Lift- et 'Release Adjuster', limiteur de charge (CEC), anémomètre, limitation de zone de travail, interrupteur de fin de course de levage et de treuil, indicateur du nombre de tours, soupapes de sécurité contre ruptures des conduites et flexibles, clapets sur vérins hydraulique.

Équipement supplémentaire (avec supplément de prix)

Fléchette: Light fixed jib 6,0 m - 24,0 m, Fixed jib 13,5 m - 49,5 m, HTLJ 10,3 m - 31,0 m, moufles de 12,5 t à 250 t, 2^{ième} treuil de levage, contrepoids additionnel de 20 t / 40 t, refroidisseur d'huile supplémentaire, peinture spéciale et inscription.

Autres équipements supplémentaires sur demande.

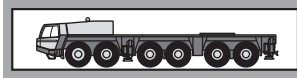

Chasis portante Construcción en acero de alta resistencia soldado, resistente a la torsión y flexión. Engrase centralizado.

Estabilizadores Estabilizadores hidráulicos de 4 puntos. Posibilidad de manejo desde ambos lados del chasis y desde la cabina de la grúa. Base de apoyo 8,5 m (variante 8,0 m, 6,8 m, 5,5 m) x 8,9 m.

Motor Mercedes Benz 8 cilindros; OM 502 LA (Euromot III B), refrigerado por agua.
Potencia de 480 kW (653 CV) a 1800 min⁻¹; par 3000 Nm (275 kpm) a 1300 min⁻¹. Potencia de motor según 80 / 1269 / EWG. Depósito de combustible de 450 l. Depósito AdBlue 40 l.

Transmisión Transmisión mecánica modelo ZF-TC Tronic "Heavy Duty". Con convertidor y embrague de puente con Intarder integrado, accionamiento electro-neumático. Embrague seco cambio automático con 12 marchas delanteras + 2 traseras. Modo rendimiento máximo / económico.

Tracción 12 x 8 x 12

Ejes

- 1° eje: direccional, accionado, con bloqueo diferencial transversal.
- 2° eje: direccional.
- 3° eje: direccional, accionado, con bloqueo diferencial transversal + longitudinal.
- 4° eje: direccional, accionado, con bloqueo diferencial transversal.
- 5° eje: direccional, accionado, con bloqueo diferencial transversal.
- 6° eje: direccional.

Suspensión Suspensión hidroneumática con regulación de nivel.

Sistemas de frenos Accionamiento neumático con frenos de disco. Frenos de estacionamiento tipo muelles cargados, en los ejes 3°, 4°, 5° y 6°. Intarder con sistema automático de frenado continuo. Sistema de estrangulador sobre el escape.

Neumáticos 12 x 445/95 R 25 (16.00 R 25), ancho 3 m.

Dirección Dirección hidráulica ZF Servocom de doble circuito y bomba auxiliar de dirección. Dirección mecánica en los ejes 1° y 2°. Ejes 3° - 6° en servicio modo circulación "carretera" acompañan la dirección hasta una velocidad de 30 km/h. A partir de 30 km/h los ejes 4° - 5° se bloquean y quedan sin dirección. A partir de 50 km/h quedan sin dirección los ejes 3° - 6°.

Cabina Cabina para dos personas, en construcción de acero de fibra de vidrio. Cristales de seguridad, asiento con suspensión neumática y calefactado. Calefacción por agua caliente del motor, climatización, radio-CD-player. Elementos de control e instrumentación para la circulación por carretera. Regulador de velocidad, sistema automático de frenado.

Sistema eléctrico Sistema de 24 V c.c. con dos baterías, conexiones eléctricas integradas en el sistema CAN-Bus, sistema integrado de diagnóstico Faun-CSS. Faros de trabajo en los estabilizadores. El sistema eléctrico cumple la normativa CEE.

Equipo adicional (con suplemento de precio)

Embrague de remolque, calefacción adicional con precalefacción del motor, ABS, neumáticos 525/80 R 25 (20.5 R 25) / ancho 3,2 m, rueda de repuesto, pintura especial y rotulación.

Otros equipamientos sobre pedido.

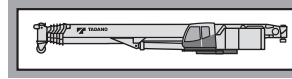

Superestructura Construida en aceros soldados, resistente a la torsión. Corona de giro de dientes externos con un giro de 360°.

Motor Mercedes Benz 6 cilindros modelo OM 926 LA (Euromot III B), refrigerado por agua. Las revoluciones aumentan de forma gradual accionado por el acelerador. Potencia 195 kW (265 Cv) a 2200 min⁻¹. Par 1100 Nm (112 kpm) a 1200 -1600 min⁻¹. Potencia de motor según normativa DIN 6270B / DIN 6271. Depósito de combustible 230 l; depósito de AdBlue 8 l.

Sistema hidráulico Sistema hidráulico de 3 circuitos, 1 bomba doble de pistones axiales (regulada hidráulicamente) 1 bomba axial y 1 bomba dentada. Enfriador de aceite.

Mandos 2 palancas de control de tipo joy-stick para movimientos simultáneos de la grúa (4 direcciones), asistidos eléctricamente.

Pluma telescópica Pluma telescópica compuesta de 5 tramos de acero de alta resistencia, 1 trama base + 4 tramos telescópicos, extensibles bajo carga. Longitud 15,0 m - 60,0 m. Cabeza de pluma con 7 poleas.

Elevación de pluma Cilindro telescópico con válvula de anti-caída.

Cabrestante principal Motor de pistones axiales variable. Cabestrante con reducción de planetarios y frenos de disco con sistema libre de elevación. Cable de elevación con sistema fácil de guiado 'Super-Stop'.

Sistema de giro Motor hidráulico de pistones axiales con reducción planetaria de tres etapas. Circuito hidráulico abierto con posibilidad con reductor posición veleta. Velocidad de giro gravable desde 0 - 1,1 min⁻¹.

Contrapeso Peso total 98 t divisible. Accionamiento mediante mando a distancia.

Cabina de la grúa Cabina espaciosa y confortable en construcción de acero de fibra de vidrio. Con cristales tintados de seguridad. Asiento de conductor amortiguado hidráulicamente, calefactado. Calefacción independiente, climatización, radio-CD-player. Controles e instrumentación a sí como display digital LCD para la operación de la grúa.

Sistema eléctrico Sistema de 24 V c.c. con dos baterías.











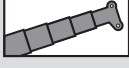
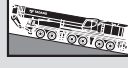
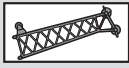







Medidas de seguridad Sistema de 'Lift- and Release Adjuster' limitación de momentos de carga (LMC). Anemómetro limitación de área de trabajo. Final de carrera, control de cabestrante, indicador de vueltas de cabestrante, válvulas de seguridad contra rotura de tuberías y latiguillos. Válvulas de cierre en cilindros hidráulicos.

Equipo adicional (con suplemento de precio)

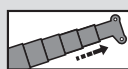
Plumin: Light fixed jib 6,0 m - 24,0 m, Fixed jib 13,5 m - 49,5 m, HTLJ 10,3 m - 31,0 m, Pastecas desde 12,5 t - 250 t, 2° cabrestante, enfriador adicional, contrapeso adicional de 20 t / 40 t, pintura especial y rotulación.

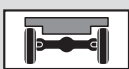
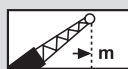
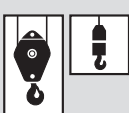
Otros equipamientos sobre pedido.

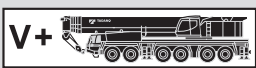
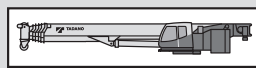
Symbolerklärung
 Symbols
 Glossaire des symboles
 Glosario de símbolos

	Teleskopausleger Telescopic boom Flèche télescopique Pluma telescópica		Steigfähigkeit Gradeability Abtitude en pente Superacion de pendientes
	Auslegerverlängerung Boom extension Fléchette Plumín		Gelände Off road Tout-terrain Todo terreno
	Auslegerverlängerung hydraulisch Boom extension hydraulically Fléchette hydrauliquement Plumín hidráulicamente		Straße On road En route En carretera
	Auslegerverlängerung HTLJ Boom extension HTLJ Fléchette HTLJ Plumín HTLJ		Geschwindigkeiten Oberwagen Superstructure speeds Vitesses du partie tournante Velocidades de la superestructura
	Abstützung Outriggers Calage Estabilizadores		Hubwerk Main winch Mécanisme de levage Cabrestante principal
	Drehwerk Slewing system Orientation Sistema de giro		2. Hubwerk Auxiliary winch 2 ^{ème} treuil de levage 2 ^o cabrestante
	Gegengewicht Counterweight Contrepoids Contrapeso		Wippwerk Derricking system Mécanisme de relevage Elevación de pluma
	Siehe Seite 40 As on Page 40 Voyez la page 40 Véase la pagina 40		Teleskopieren Boom telescoping Télescopage de flèche Telescopaje de pluma
	Räder / Größe Tyres / Size Pneus / Largeur Neumáticos / Tamaño de ruedas		Ausladung Radius Portée Radio
	Achslast Axle load Charge à l'essieu Carga por eje		Ausladung Radius Portée Radio
	Unterflasche / Hakengeschrir Hook block / Swivel hook Moufle / Elingues Gancho / Gancho de bola		Unterwagen Carrier châssis chasis
	Geschwindigkeiten Unterwagen Carrier speeds Vitesses du châssis Velocidades del chasis		Oberwagen Superstructure partie tournante superestructura
	Getriebe / Gang Transmission / Gear Boîte de vitesse / Rapport Transmisión / Marchas		

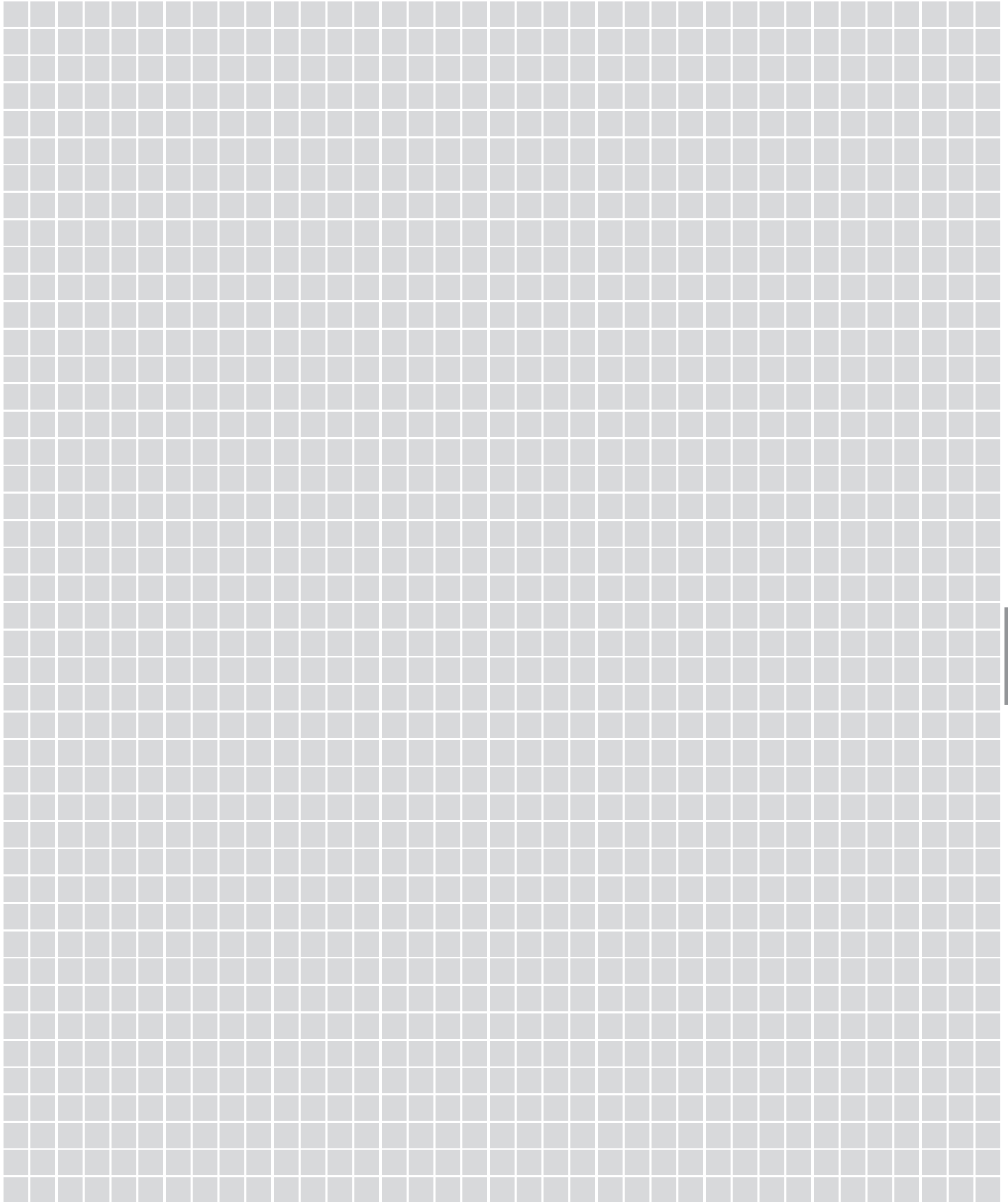

7



TADANO FAUN GmbH

Faunberg 2, 91207 Lauf a. d. Pegnitz, Germany
Phone: +49-9123-185-0 Fax: +49-9123-3085
<http://www.tadanofaun.de> E-mail: info@tadanofaun.de

TADANO LTD. (International Division)

4-12, Kamezawa 2-chome, Sumida-ku Tokyo 130-0014, Japan
Phone: 81-3-3621-7750 Fax: 81-3-3621-7785
<http://www.tadano-global.com> E-mail: tdnihq@tadano.co.jp