

15/105

Articulating Crane



► 15/105 Articulating Crane

Strength and reach come together in our 15/105 articulating cranes, with a max lifting capacity of 12,125 lb (5500 kg) for the SL model and 13,740 lb (6110 kg) for the DL model. A horizontal reach of 56 ft 5 in (17.2 m) make both of these compact cranes high-performing, must-have pieces of equipment for your job sites. What's more, they have hexagonal booms for greater strength and stability, the ability to stow within themselves, and unique features and options for easy operation.



15/105SL Specifications

	1 - Hydraulic	2 - Hydraulic	3 - Hydraulic	4 - Hydraulic	5 - Hydraulic	6 - Hydraulic
Crane Rating*	104,880 ft-lb (14.5 tm)	101,260 ft-lb (14 tm)	98,370 ft-lb (13.6 tm)	95,475 ft-lb (13.2 tm)	92,580 ft-lb (12.8 tm)	90,415 ft-lb (12.5 tm)
Max Horizontal Reach	20' 4" (6.2 m)	27' 3" (8.3 m)	34' 1" (10.4 m)	41' 8" (12.7 m)	48' 11" (14.9 m)	56' 5" (17.2 m)
Max Vertical Reach	28' 7" (8.7 m)	35' 5" (10.8 m)	42' 4" (12.9 m)	49' 10" (15.2 m)	57' 1" (17.4 m)	64' 8" (19.7 m)
Max Capacity	12,125 lb (5500 kg)	11,575 lb (5250 kg)	11,135 lb (5050 kg)	10,690 lb (4850 kg)	10,205 lb (4630 kg)	9920 lb (4500 kg)
Max Cap @ Max Reach	5135 lb (2330 kg)	3660 lb (1660 kg)	2645 lb (1200 kg)	1940 lb (880 kg)	1435 lb (650 kg)	1060 lb (480 kg)
Crane Weight **	3020 lb (1370 kg)	3330 lb (1510 kg)	3640 lb (1650 kg)	3935 lb (1785 kg)	4200 lb (1905 kg)	4410 lb (2000 kg)
Hook Approach						
Vertical	9' 1" (2.76 m)	8' 11" (2.71 m)	8' 7" (2.62 m)	8' 4" (2.53 m)	8' 0" (2.44 m)	7' 9" (2.35 m)
Horizontal	2' 5" (0.74 m)	2' 7" (0.79 m)	2' 9" (0.84 m)	2' 11" (0.89 m)	3' 1" (0.94 m)	3' 3" (1 m)
Center of Gravity - Stored						
Vertical	2' 5" (730 mm)	2' 6" (755 mm)	2' 7" (780 mm)	2' 8" (805 mm)	2' 8" (805 mm)	2' 8" (820 mm)
Horizontal (C/L Rotation to Bridge)	14" (355 mm)	13.8" (350 mm)	13.2" (335 mm)	12.6" (320 mm)	12" (305 mm)	11.4" (290 mm)

15/105DL Specifications

	1 - Hydraulic	2 - Hydraulic	3 - Hydraulic	4 - Hydraulic	5 - Hydraulic	6 - Hydraulic
Crane Rating*	104,880 ft-lb (14.5 tm)	101,260 ft-lb (14 tm)	98,370 ft-lb (13.6 tm)	95,475 ft-lb (13.2 tm)	92,580 ft-lb (12.8 tm)	90,410 ft-lb (12.5 tm)
Max Horizontal Reach	20' 4" (6.2 m)	27' 3" (8.3 m)	34' 1" (10.4 m)	41' 8" (12.7 m)	48' 11" (14.9 m)	56' 5" (17.2 m)
Max Vertical Reach	28' 7" (8.7 m)	35' 5" (10.8 m)	42' 4" (12.9 m)	49' 10" (15.2 m)	57' 1" (17.4 m)	64' 8" (19.7 m)
Max Capacity	13,470 lb (6110 kg)	13,115 lb (5950 kg)	12,520 lb (5680 kg)	11,970 lb (5430 kg)	11,465 lb (5200 kg)	11,000 lb (4990 kg)
Max Cap @ Max Reach	5135 lb (2330 kg)	3640 lb (1650 kg)	2645 lb (1200 kg)	1940 lb (880 kg)	1435 lb (650 kg)	1060 lb (480 kg)
Crane Weight **	3130 lb (1420 kg)	3440 lb (1560 kg)	3750 lb (1700 kg)	4045 lb (1835 kg)	4310 lb (1955 kg)	4520 lb (2050 kg)
Hook Approach						
Vertical	9' 1" (2.76 m)	8' 11" (2.71 m)	8' 7" (2.62 m)	8' 4" (2.53 m)	8' 0" (2.44 m)	7' 9" (2.35 m)
Horizontal	2' 5" (0.74 m)	2' 7" (0.79 m)	2' 9" (0.84 m)	2' 11" (0.89 m)	3' 1" (0.94 m)	3' 3" (1 m)
Center of Gravity - Stored						
Vertical	2' 7" (785 mm)	2' 7" (800 mm)	2' 8" (820 mm)	2' 9" (835 mm)	2' 9" (850 mm)	2' 10" (860 mm)
Horizontal (C/L Rotation to Bridge)	13" (330 mm)	12.8" (325 mm)	12.4" (315 mm)	12" (305 mm)	11.8" (300 mm)	11" (280 mm)

* Crane rating (ft-lb) is the rated load (lb) multiplied by the respective distance (ft) from centerline of rotation with all extensions retracted and the inner and outer booms in a horizontal position, per ANSI B30.22. ** Crane weight does not include stabilizers.

Standard Features

- Application-specific product offering
- Superior lift-to-weight ratio
- Long-reach capabilities
- Hexagonal booms for superior reach and maximum control
- Internal hose routing
- 15° overbending on outer boom

Options

- Radio remote control
- Various stabilizer configurations
- Double link arm system
- Boom mounted winch
- Floodlight on outer boom
- Boom tip functions for hydraulic attachments
- Oil cooler

Specifications

Stabilizer Pad Diameter	6" (160 mm)
Crane Storage Height	7' 5" (2250 mm)
Mounting Space***	2' 8" (820 mm)
Rotational Torque	12,295 ft-lb (1.7 tm)
Rotation	400°
Optimum Pump Performance	13.2 gpm (50 L/min)
System Pressure	4350 psi (300 bar)
Oil Reservoir Capacity	23.8 gal (90 L)
Stabilizer Extension Span	
Standard (manual out/hydraulic down)	15' 2" (4615 mm)
Weight	440 lb (200 kg)
Opt. 1 (manual out/hydraulic down)	18' 4" (5590 mm)
Weight	520 lb (235 kg)
Opt. 2 (hydraulic out/hydraulic down)	21' 3" (6470 mm)
Weight	660 lb (300 kg)

*** Maximum swing clearance radius required is 24" (600 mm) at 7' 10" (2375 mm) from top of chassis frame.

Minimum Chassis Specifications

Front Axle Rating (GAWR)	12,000 lb (5445 kg)
Rear Axle Rating (GAWR)	21,000 lb (9525 kg)
Resistance to Bending Moment Minimum	1,850,000 in-lb (213,145 kg-m)

Hexagonal Boom Design

A wide hexagonal profile with large bearing surfaces ensures greater strength and stability for horizontal and vertical spans — even when working in extreme positions with long reaches. Plus, it's protected by powdercoat paint that never fades, flakes, or corrodes.



Internal Hose Routing

Fed internally through protective nylon drag chains or roller guides, all hoses are equipped with sturdy, high-pressure swivel couplings to prevent them from twisting.



Overbending

Overbending between the main boom and jib provides greater flexibility when working under power wires and more potential for high lifting in narrow passages. It also lowers the total height when the loader is stowed over the truck body.



Stow Bracket Innovation

The stow bracket is designed to secure the boom for transport position but not allow for bracket damage. Unlike systems with rigid fixed brackets, the "J" hook will pivot if an incorrect movement is attempted.

► 15/105SL Capacity Charts

15/105SL K1

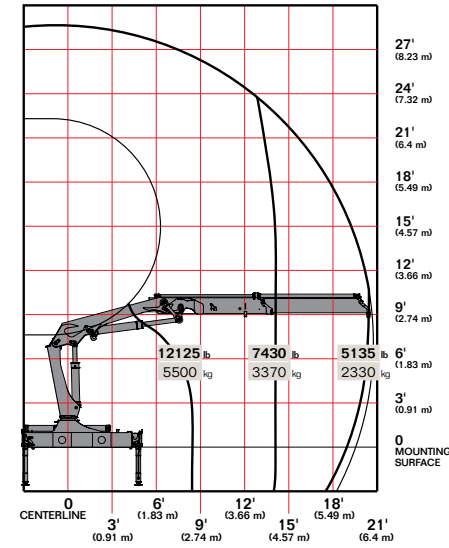

15/105SL K2

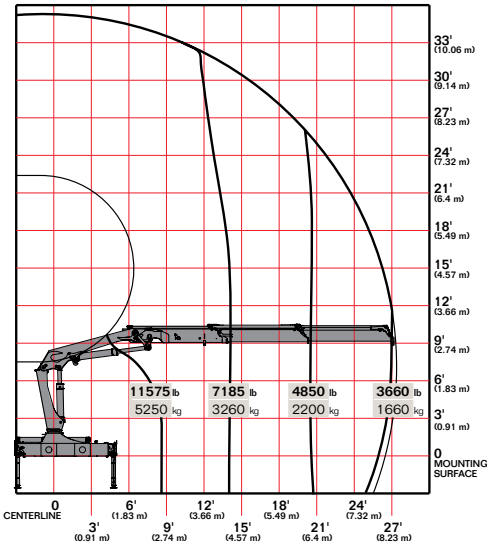

15/105SL K3

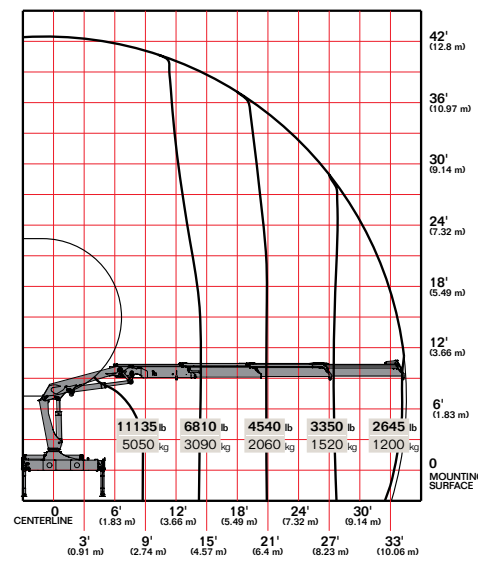

15/105SL K4

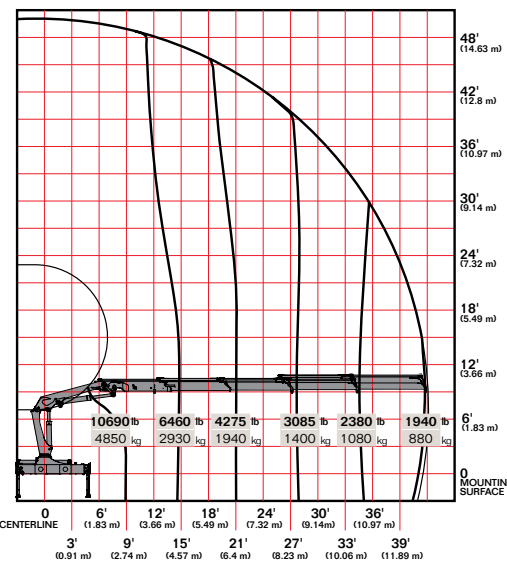

15/105SL K5

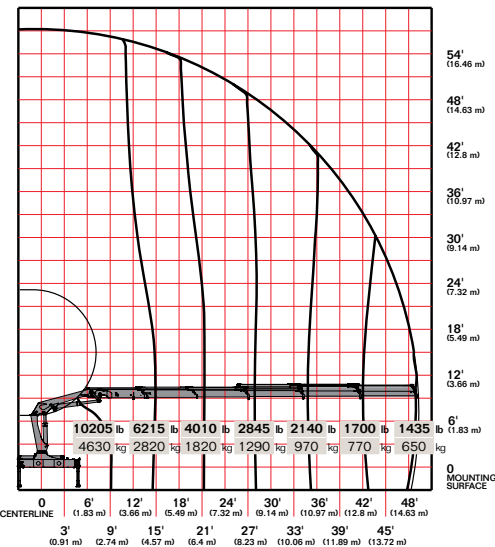

15/105SL K6

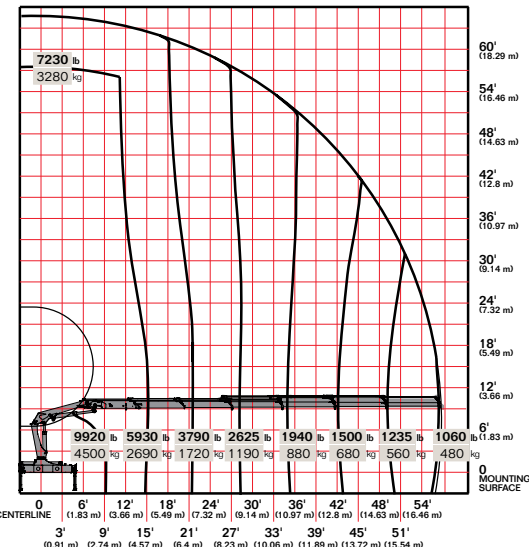

► 15/105SL Lifting Capacity

15/105SL - 1 Hydraulic

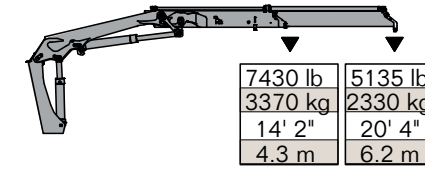

15/105SL - 2 Hydraulic

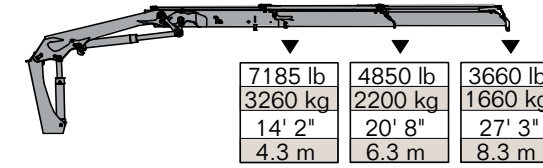

15/105SL - 3 Hydraulic

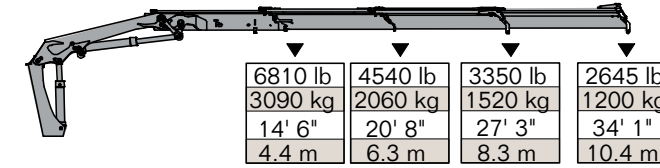

15/105SL - 4 Hydraulic

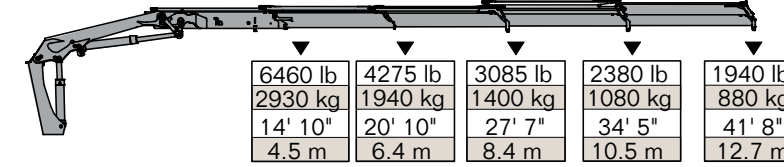

15/105SL - 5 Hydraulic

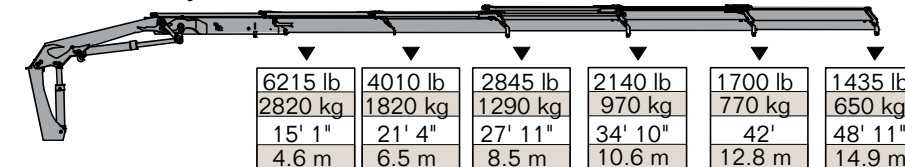

15/105SL - 6 Hydraulic

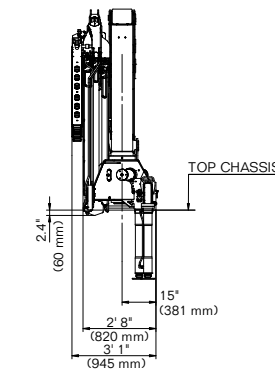
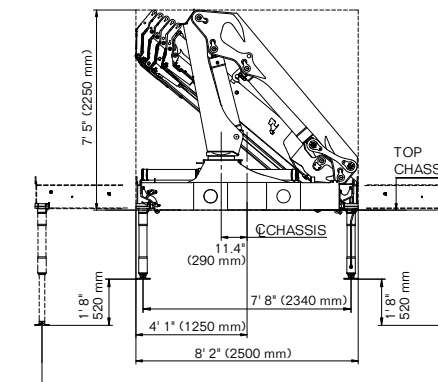
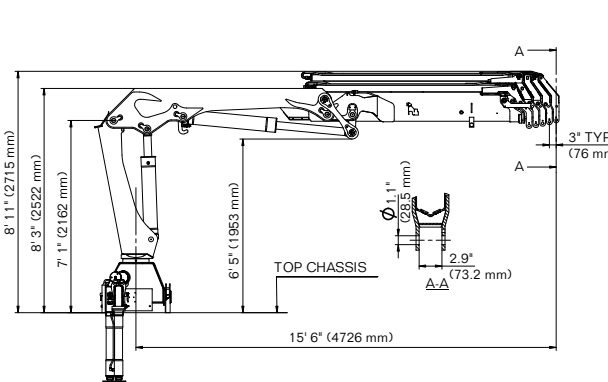
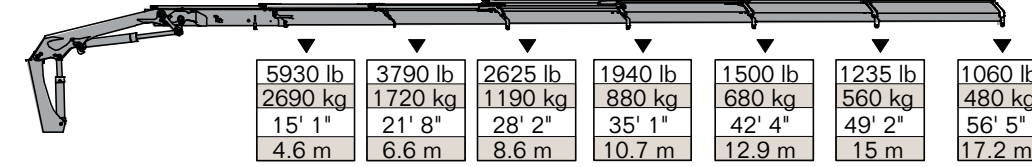

Limit working loads to those shown. Deduct the weight of load-handling devices.

► 15/105DL Capacity Charts

15/105DL K1

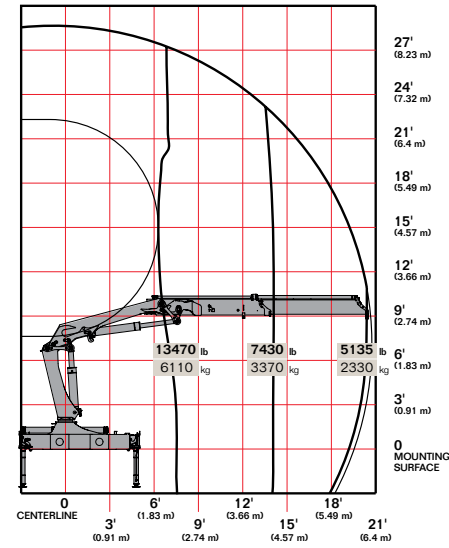

15/105DL K2

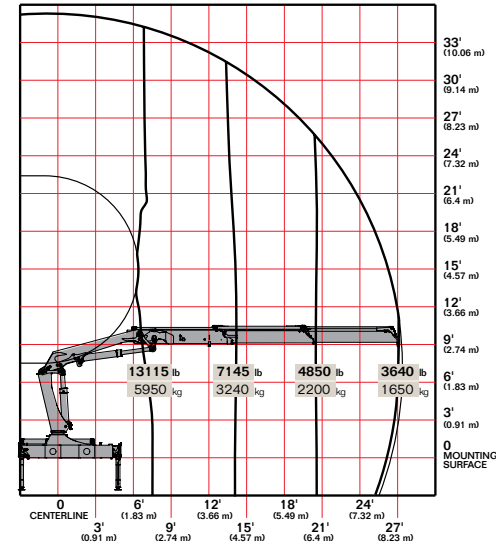

15/105DL K3

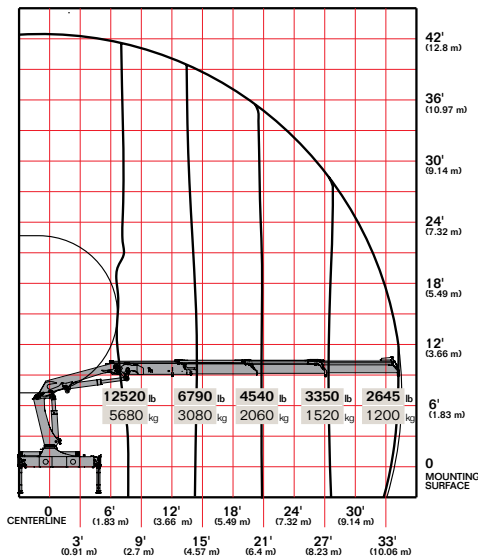

15/105DL K4

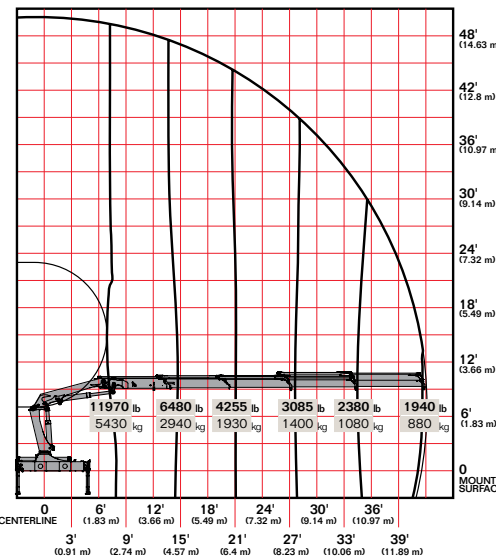

15/105DL K5

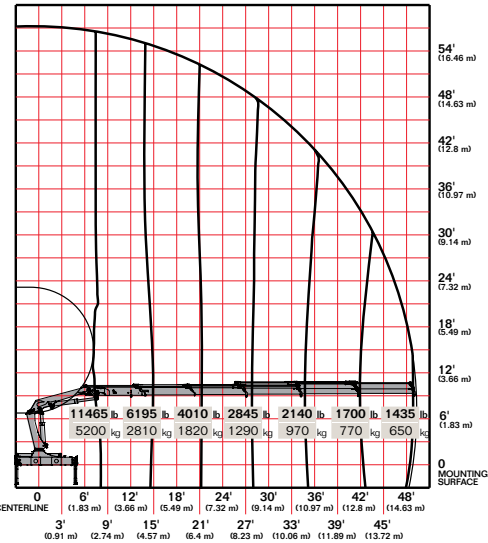

15/105DL K6

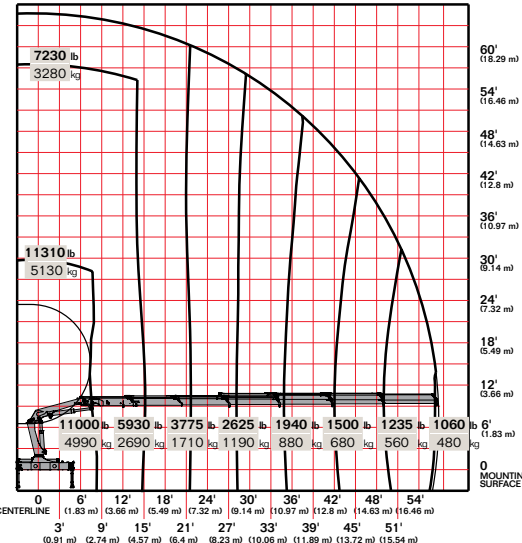

► 15/105DL Lifting Capacity

15/105DL - 1 Hydraulic

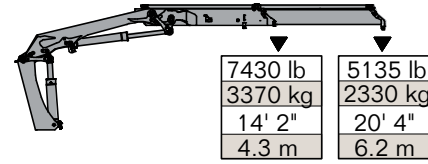

15/105DL - 2 Hydraulic

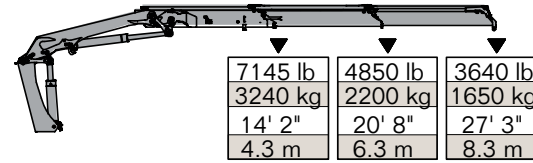

15/105DL - 3 Hydraulic

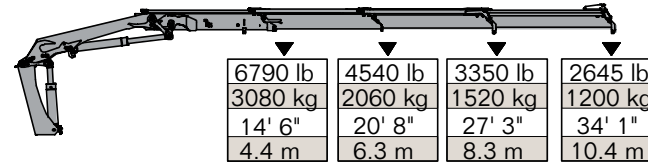

15/105DL - 4 Hydraulic

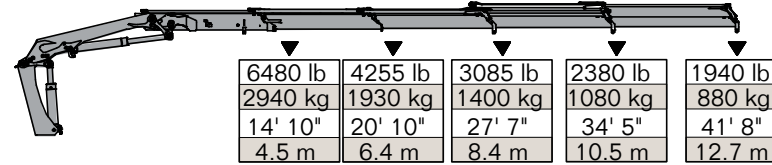

15/105DL - 5 Hydraulic

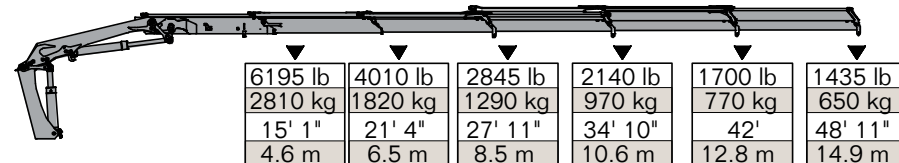

15/105DL - 6 Hydraulic

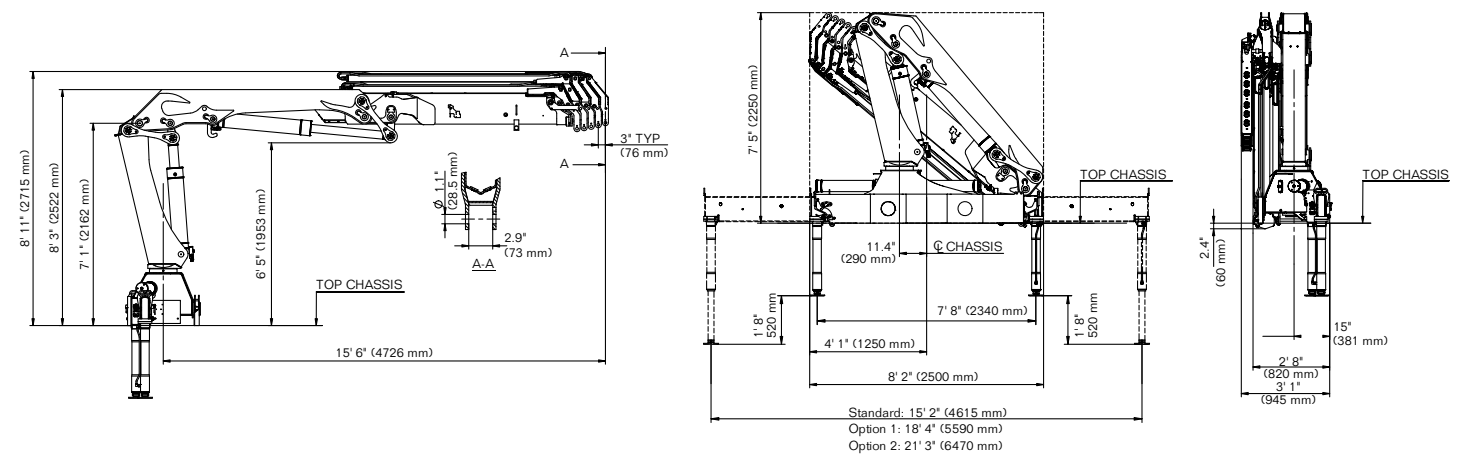
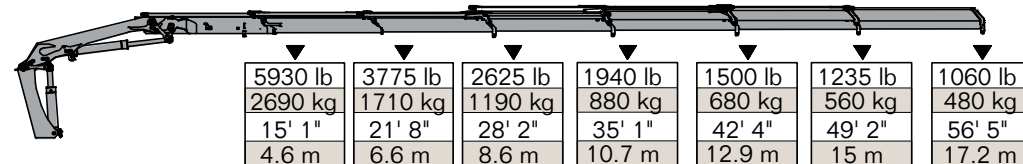

Limit working loads to those shown. Deduct the weight of load-handling devices.

Power Source

- Standard integral-mounted piston hydraulic pump and PTO application

Cylinder Holding Valves

- Integral-mounted counterbalance valves or load-holding check valves
- Prevention of sudden cylinder collapse in case of hose failure

Rotation System

- 400 degree rack and pinion
- 12,295 ft-lb (1.7 tm) rotational torque
- Counterbalance valve on each cylinder to stop motion in case of hose failure

Hydraulic System

- Open-centered system — closed optional
- Regeneration system on extension cylinder to ensure quick deployment
- Hydraulic oil reservoir, air breather, replaceable return-line filter, and control valve with levers

Overload System

- Load-limiting capability for boom functions
- Rated capacity limitation (RCL) 5300 blocks load-increasing functions when full capacity is attained



Nothing Says Commitment Like The Diamond.™

IMT has been meeting the needs of our customers for over 50 years and none of it would have been possible without a distributor network that's second to none. IMT distributors offer fast, knowledgeable service and the ability to help customers find the right product for every application. When you're looking for reliable equipment and dependable service, remember IMT.



An Oshkosh Corporation Company

Iowa Mold Tooling Co., Inc.
500 Highway 18 West
Garner, Iowa 50438
800-247-5958 • www.imt.com

IMT reserves the right to make changes in engineering, design, and specifications; add improvements; or discontinue manufacturing at any time without notice or obligation. IMT, the IMT logo and NOTHING SAYS COMMITMENT LIKE THE DIAMOND are registered trademarks or trademarks of Iowa Mold Tooling Co., Inc., Garner, IA, USA.
© 2013 Iowa Mold Tooling Co., Inc. All Rights Reserved.