

**61-RB**

**61-RB**

**61-RB**

**61-RB**

**61-RB**

**61-RB**

**61-RB**

**61-RB**

**61-RB**

**61-RB heavy duty**

**61-RB**

**61-RB**

**61-RB**

**EXPORT RATINGS**

**61-RB**

**61-RB**

**61-RB**

**61-RB**

**61-RB**

**61-RB**

**61-RB**

**61-RB**

**61-RB**

**61-RB heavy duty**

**61-RB**

**61-RB**

**61-RB**

**Contents**

General description of superstructure, crawler mounting and front-end equipment	3 & 4
Machine options	5
Approximate weights	6
Clearance dimensions	6
Crawler mounting	6
Power units and rope data	7
Rear-hitch lowerable A-frame	7
Lifting crane range diagram	8
Lifting crane main-boom service notes	9
Lifting crane main-boom ratings	10 & 11
Fly-jib service notes	12
Fly-jib ratings	13
Dragline and grabbing crane range diagram	14
Dragline and grabbing crane ratings and service notes	15
Dragline bucket data	16
Grab bucket data	17
Transportation	18

# superstructure



## Revolving frame

Single-unit heat-treated cast alloy-steel revolving frame of deep box-section design provides rigid foundation for main machinery and power unit. Integral boom-foot lugs.

## Main machinery

Simple, open layout for efficient transmission of power. Cast-steel machinery side frames bolted to revolving frame and located by shear plugs.

Single main shaft with side-by-side drums. Swing transmission shaft and boom-hoist unit separately mounted for accessibility. Drumshaft and two-piece main transmission shaft are of heat-treated alloy-steel and mounted in anti-friction bearings. Cast alloy-steel main hoist gear with machine-cut hardened teeth.

## Hoist drums

Specially developed hoist drums with Lebus laggings providing adequate rope capacity to match requirements of long boom and fly-jib range.

Power-controlled load lowering is standard equipment for main hoist drum and available for auxiliary hoist.

## Drum clutches and brakes

Concentric brake and clutch contact surfaces are separated by cooling spaces. Air-controlled clutches are internal-expanding band-type. External contracting band-type brakes with choice of application systems to suit operating requirements; air-assist is standard; full-air and fail-safe systems optional for lifting crane; direct mechanical for bucket service. Split drum laggings for easy removal.

## Boom hoist

Independent boom hoist with single lever control for raising and lowering clutches, safety pawl and spring-set air-released brake. Lebus lagging for correct spooling.

## Swing/propel machinery

Air-controlled quick-shift spline-type clutches engage either horizontal swing gear or propel gear.

Clutches interconnected to prevent simultaneous engagement. Internal-expanding two-shoe type reversing clutches, air-controlled. Special propel bevel pinion design allows speedy removal of superstructure for transportation.

Engine-driven blower system for swing/propel reversing clutches, with optional extensions to operating clutches and brakes, gives positive cooling.

## Swing brake

V-type swing brake is applied directly to top of vertical swing shaft and has air-assisted spring setting. Brake release is by hand-operated control valve delivering graduated air pressure to balance the application pressure, releasing the brake under extremely accurate control.

## Swing lock

Swing lock assembly for positively locking the superstructure to the crawler mounting, i.e. when the machine is being transported. A divert valve is incorporated on the swing lock control lever which reduces air pressure to the swing clutches bringing swing movement to a minimum thereby facilitating the application of the swing lock.

## Lubrication

All gears shielded; lubrication fittings easily accessible or grouped in centralised locations. Lubricating-gun mounted inside the operator's compartment lubricates the horizontal gears, swing rack and hoist gears.

## Counterweight and counterweight handling

Stability counterweight consists of slab weights bolted to the rear of the superstructure. These counterweights, and also the rear-end casting, can be removed by means of an independent hydraulic assembly, details of which are given on page 5.

## Operator's controls and cab

Air control for all machine functions. All-metal cab with separate offset operator's compartment.

Wide-opening doors and hatches provide easy access to machinery.

Full vision through large safety-glass windows. Wiper for upper front window.

## Twin-lever dual-governor control

Two independent levers, conveniently located at the driver's position, provide sensitive control of the setting of the engine and torque-converter output-shaft governors. This system enables the relationship between power and speed to be adjusted to suit operating conditions.

# crawler mounting

Specially designed to give increased stability and manoeuvrability for heavy lifting service.

## Side frame assemblies

Single-unit cast alloy-steel side frames.

Round-type driving tumblers are heat-treated alloy-steel castings for smooth propel and long life. Tumblers are mounted on adjustable shafts for maintaining propel-chain tension. Heat-treated alloy-steel take-up tumblers are similarly mounted for crawler belt adjustment.

Upper rollers are bushed castings. Lower rollers are bushed alloy-steel castings, differentially hardened. The rollers are small diameter single-path type providing good support along the lower length of the crawlers combined with lateral flexibility.

The roller shafts are housed in bearing blocks which are bolted to the underside of the crawler frame.

Bearings have piston-ring type seals. Track links are heat-treated alloy-steel with hardened roller path and driving lugs. Two-pin connexion.

Each side frame, complete with crawler links and propel chains, can be removed as a unit to reduce the size and weight of the crane for transportation purposes. A special stub shaft with square-section mating-ends is incorporated into each outer section of the horizontal propel shaft to facilitate this operation.

The optional hydraulic counterweight handling assembly can be used to assist in the removal and installation of the crawler side frames.

## Axles

Deep I-section cast alloy-steel axles secured to truck frame by large bolts and shear plugs. Machined axle ends located in side frames allowing easy removal for transportation purposes.

## Propel machinery

Power transmitted directly from vertical propel shaft in truck frame to driving chains by a bevel gear reduction and horizontal propel shaft.

Propel bevel gears are enclosed and run in oil. Easy manoeuvrability by spring-set air-released steering jaw clutches and V-type propel brakes. Interlock of clutches prevents simultaneous disengagement.

Brakes are set by springs with air-assist for extra holding power.

## Truck frame

One-piece heat-treated alloy-steel casting designed to accommodate the ball-bearing swing circle and incorporating an integral oil-tight housing for the propel bevel gears.

X-design ensures strength and accurate alignment of horizontal and vertical propel shafts.

Towing eyes are provided at the front of the truck frame.

## Swing circle

Consists of two independent rows of precision balls and spacers. Permanently adjusted and requires only occasional lubrication. Mounted on the truck frame and bolted to the revolving frame, the swing circle incorporates the internal-tooth flame-hardened swing rack.

# front-end equipment

The boom is of welded lattice construction with high-tensile alloy-steel angle chord members and round-tube lacing members. The sheave pins in the boom point structure carry the four main hoist sheaves for lifting crane service. All boom-head sheaves are mounted on ball bearings.

The boom point can be quickly connected for dragline or grabbing crane service.

Basic boom length is 50ft 15,24m comprising a 25ft 7,62m lower section and a 25ft 7,62m upper section, which can be extended to maximum of 160ft 48,77m by the insertion of 10ft 3,05m, 20ft 6,10m and 30ft 9,14m intermediate sections.

A fly jib of 15ft 4,57m or 30ft 9,14m in length is available to extend the range of the lifting crane equipment.

Multi-piece pendent suspension is employed with multi-part continuous rope suspension between the rear-hitch lowerable high A-frame and the floating bridle; with multi-piece pendants from the floating bridle to the boom point.

All boom lengths can be raised from ground level without assistance by means of the rear-hitch lowerable A-frame in the raised position; with multi-part continuous rope suspension between the A-frame and the floating bridle and multi-piece pendants between the floating bridle and the boom point.

# heavy-duty machine options

Different crane applications call for different crane equipment. Heavy-duty machines can be fitted with a number of optional items to suit different site requirements.

## **Independent propel**

Gives immediate propel availability or machine movement in conjunction with swing for accurate load location in crane work; includes gears, air-operated clutches and brakes, mounted in special bracket.

## **Third drum**

Comprises third drum assembly mounted at boom foot, complete with drive chain and sprockets, bearing brackets, operating valves and levers.

## **Load indicators**

Standard indicator is of mechanical pendulum type with scales indicating boom angle and also load/radius for a specified boom length.

A visible and audible automatic load indicator of approved make can be fitted as an optional extra.

## **Hoist-line movement sensing unit**

This comprises drive wheel, spring-loaded against outer face of clutch housing, with flexible drive to a rotating sensing knob at the driver's position. A flexible control cable, complete with hand grip, is also provided.

## **Auxiliary hoist lagging**

Consists of a 26in 660mm diameter Lebus lagging, suitable for 22mm rope, to give auxiliary hoist facility.

## **Power-controlled lowering of auxiliary hoist line**

Comprises air-controlled drive clutch, gear and shaft, drive chain and sprockets, giving controlled reverse-motion of hoist drum.

## **Hook blocks for main hoist**

Triple-sheave block to handle maximum capacity. Single-sheave swivel-hook block available to suit other duties.

## **Boom-angle limit device**

At a pre-set boom angle, the air supply to the boom-hoist clutch is exhausted and the boom-hoist brake is automatically set, thus preventing the boom from exceeding the maximum angle. A warning whistle is also incorporated.

## **Hydraulic counterweight-handling assembly**

Comprises portable hydraulic-pump unit powered by single-cylinder petrol engine, controls, hoses with quick-release couplings, cylinders and hydraulic fluid. Links to enable unit to be used for crawler side-frame movement included.

## **Blower equipment for operating clutches and brakes**

Additional ducting to right-hand or left-hand operating clutch and brake, as specified by customer.

## **Alternative systems for operating brakes**

Full-air type, retaining operator "feel", may be fitted in place of standard air-assisted type.

Also available:

Fail-safe system with spring-set, air-released brakes for lifting crane.

Direct mechanical type for bucket service.

## **Alternative power unit**

Dorman 8JT turbo-charged water-cooled diesel with torque-converter may be supplied as an alternative to the Cummins NT855PTC.

## **Lighting equipment**

Engine-driven alternator with rectifier provides 24-volt dc supply for cab-mounted floodlights, interior lights and hand-lamp. Additional boom-mounted floodlights available.

## **Air-operated fuel transfer pump**

Can be fitted instead of standard manual semi-rotary pump.

## **Heater for operator's compartment**

Water-circulation heater with electrically-driven fan.

## **Extra windscreen wiper**

Electrically-operated wiper for lower front window of cab.

## **Windscreen washers—air-operated**

Two for upper front window of cab or one for upper front window and one for lower front window.

## **Cleaning-down hose**

Comprises air-control valve, 15ft 4.57m hose and blow gun.

## **Supplementary maintenance kits.**

For power unit and machine.

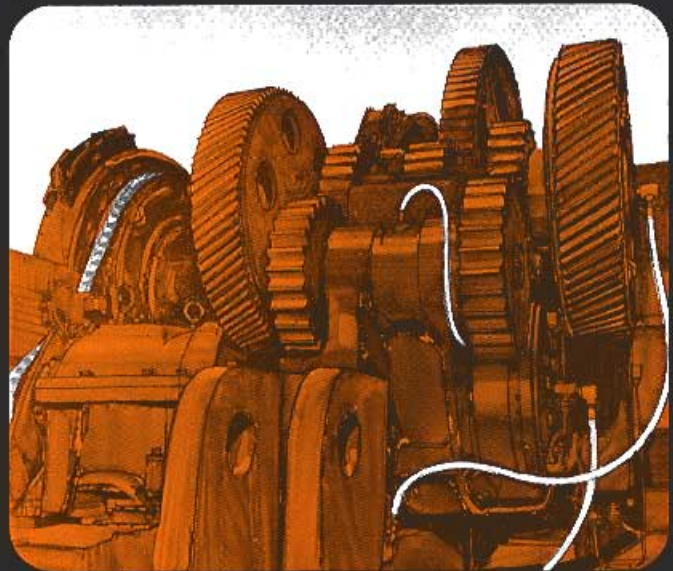

Independent propel

Third drum



Power-controlled load lowering

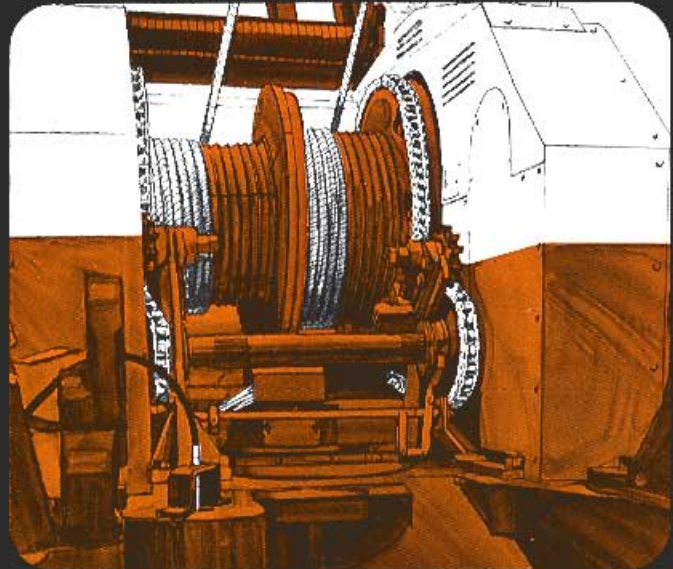

# approximate weights

With diesel power, long and wide mounting, 50ft 15,24m boom and appropriate counterweight	Lifting crane, including hook block		Dragline, including bucket		Grabbing crane, including bucket	
	lb	kg	lb	kg	lb	kg
Working	212 410	96 350	197 950	89 790	195 850	88 840
Domestic shipping	210 410	95 440	195 950	88 885	193 850	87 930
Packed for export	218 510	99 120	206 950	93 420	203 850	92 470

*The above weights will vary considerably for different combinations of front-end equipment, etc.*

Stability counterweight	Lifting crane		Dragline, grabbing crane or magnet crane	
	Amount	Location	Amount	Location
	35 000lb 15 800kg	Three 9500lb 4310kg and one 6500lb 2950kg weights outside rear-end casting	19 000lb 8620kg	Two 9500lb 4310kg weights outside rear-end casting

# clearance dimensions

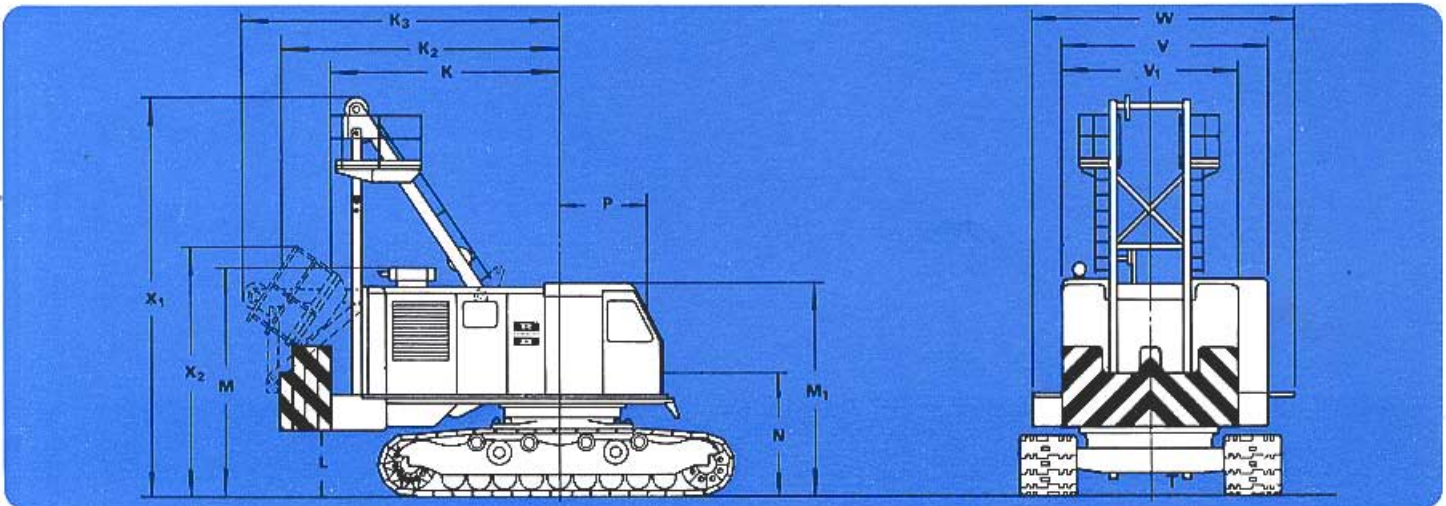

K	Clearance radius of rear-end casting	13' 11½" 4,25m	T	Clearance under mounting (propel gear-case)	1' 6" 457mm
K <sub>2</sub>	Clearance radius over external rear counterweight	16' 1" 4,90m	V	Width of cab without platforms	11' 11½" 3,56m
K <sub>3</sub>	Clearance radius over folded A-frame	18' 9¼" 5,72m	V <sub>1</sub>	Width of rear-section of cab (operator's compartment removed)	10' 6" 3,20m
L	Clearance under frame to ground level	3' 9½" 1,15m	W	Width over superstructure with platforms	15' 2" 4,63m
M	Clearance height over exhaust (handrails removed)	14' 0" 4,27m		Overall width of machine with platforms	15' 5½" 4,71m
M <sub>1</sub>	Height of cab	12' 9" 3,88m	X <sub>1</sub>	Height over erected A-frame	23' 7½" 7,20m
N	Height of boom-foot pin above ground level	7' 3¼" 2,21m	X <sub>2</sub>	Height over folded A-frame with handrails and platforms	14' 11¼" 4,55m
P	Distance from boom-foot pin to centre of rotation	5' 2" 1,58m			

# crawler mounting

	Width of track links	C to C of crawler belts	Overall width	C to C of tumblers approx.	Overall length approx.	Height of crawler tracks	Approximate bearing area
Long frame, wide axle	42" 1,07m	12' 3" 3,73m	15' 9" 4,70m	17' 3" 5,26m	20' 6" 6,25m	44" 1,12m	126ft <sup>2</sup> 11,70m <sup>2</sup>

# power units

Make and model	Cummins NT 855 PTC	Dorman 8JT
Type	Turbo-charged, water-cooled diesel	Turbo-charged, water-cooled vee-form diesel
Torque converter	Clark 16.1	Clark 16.1
Cylinders	Six, 5-50" 140mm bore x 6" 162mm stroke	Eight, 5-12" 130mm bore x 4.92" 125mm stroke
<b>Ratings:</b>		
Engine hp (gross)	291 217 kW	278 207 kW
Engine speed rev/min	2000	1900
Torque-converter output-shaft hp (net)	208 155 kW	208 155 kW
Torque-converter output-shaft speed rev/min	1300	1300
<b>Operating ranges:</b>		
Ambient temperature	— 8° C to 46° C	— 20° C to 46° C
Altitude	Up to 10 000' 3050m	Up to 5000' 1525m
Fuel tank capacity	140 gallons 636 litres	
Starting system	24-volt electric	

# laggings and ropes

## Boom suspension

Rear-hitch lowerable A-frame for all boom lengths.

10-part tackle between A-frame and bridle.

Tackle rope 19mm diameter.

Multi-piece pendants 38mm diameter.

## Lifting crane

Hoist drum, grooved (RH) 22½" diameter 571mm

Hoist rope 28mm diameter

Auxiliary hoist drum, grooved (LH) 26" diameter 660mm

Auxiliary hoist rope 22mm diameter

Boom-point sheaves (four) 27" p diameter 686mm

## Dragline

Hoist drum, grooved (LH) 26" diameter 660mm

Drag drum, grooved (RH) 26" diameter 660mm

Hoist rope, one part 26mm diameter

Drag rope, one part 28mm diameter

Boom-point sheave (one) 27" p diameter 686mm

## Grabbing crane

Hoisting and closing drum, grooved (RH) 26" diameter 660mm

Holding drum, grooved (LH) 26" diameter 660mm

Hoist rope, one part 26mm diameter

Holding rope, one part 26mm diameter

Boom-point sheaves (two) 27" p diameter 686mm

# rope pulls and speeds

Drum lagging	Diameter	One-part line				Two-part line				Three-part line			
		Pull lbf	kgf	Speed ft/min	m/min	Pull lbf	kgf	Speed ft/min	m/min	Pull lbf	kgf	Speed ft/min	m/min
Right-hand drum	22½" 571mm	37 470	17 000	158-50	48,31	72 960	33 100	79-20	24,14	108 480	48 300	52-80	16,10
	26" 660mm	32 580	14 780	182-80	55,75	—	—	—	—	—	—	—	—
Left-hand drum	26" 660mm	32 580	14 780	182-80	55,75	63 440	28 780	91-40	27,88	—	—	—	—

Swing speed: 3-6 rev/min Propel speed: 83 ft/min 25,30 m/min

Figures given are based on power unit operating at full-load speed.

When torque converter is stalled, line pulls are approximately twice the figures quoted.

## Rear-hitch lowerable A-frame

The rear-hitch A-frame can be lowered and folded over the rear of the machine to reduce overhead clearance, both for transportation and on site. All boom lengths can be raised from ground level, without assistance, by means of the rear-hitch A-frame in the raised position. With the rear-hitch A-frame lowered to reduce overhead clearance height, the maximum length of boom with which the machine can be travelled in the horizontal position is 60ft 18.29m.

# 61-RB Heavy-duty lifting crane range diagram

working radius and  
height above ground at  
various boom angles

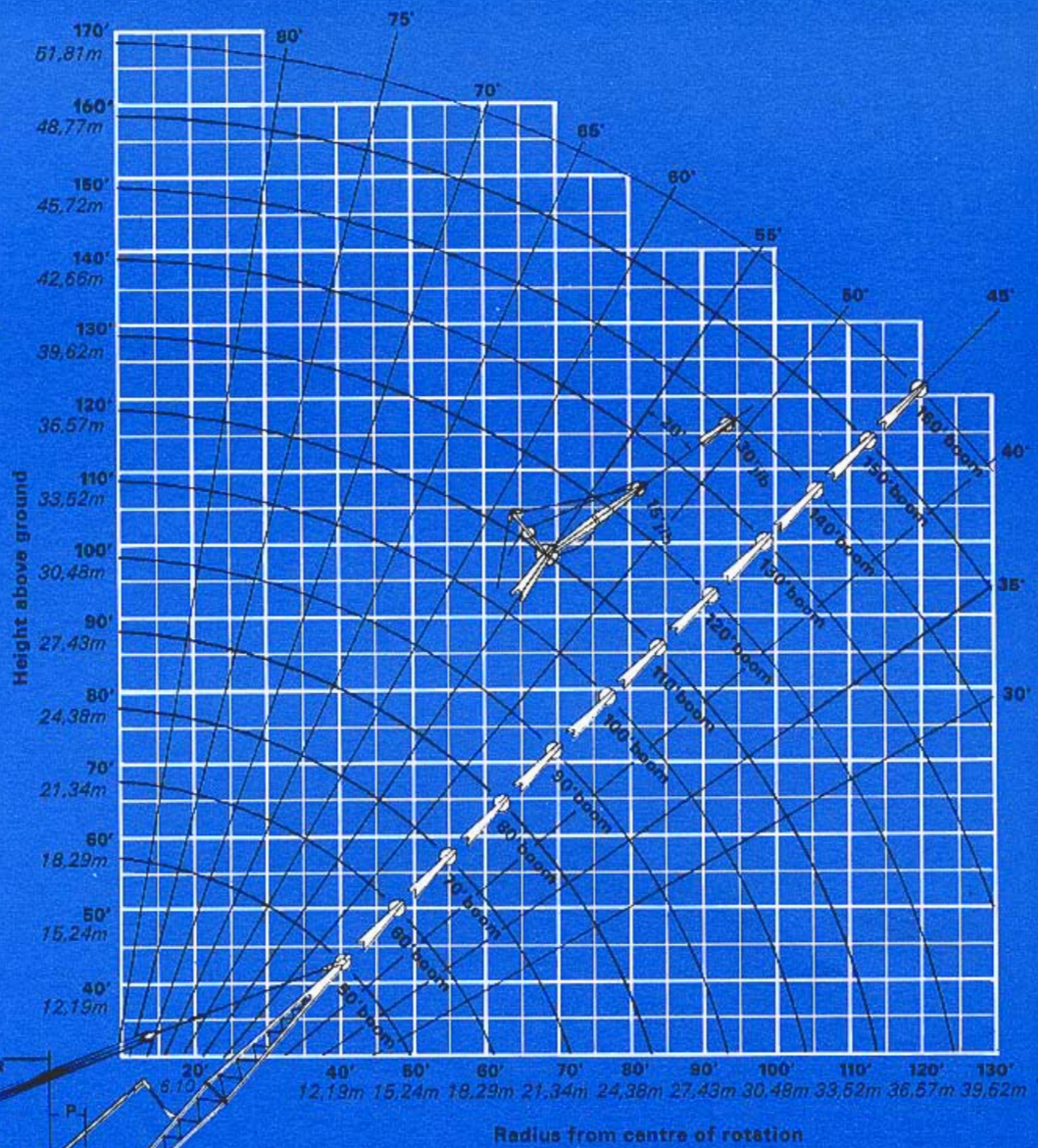

- $K_2$  Clearance radius over external rear counterweight 18' 1" / 4.90m
- $L$  Clearance under frame to ground level 3' 9 1/2" / 1.15m
- $N$  Height of boom-foot pin above ground level 7' 3 1/2" / 2.21m
- $P$  Distance from boom-foot pin to centre of rotation 5' 2" / 1.59m
- $X_1$  Height over erected A-frame 23' 7 1/2" / 7.20m

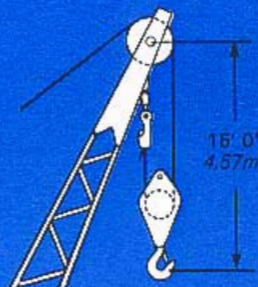

**Main hoist**  
93.5 tonnes  
triple-sheave hook block  
41.7 tonnes  
single-sheave hook block

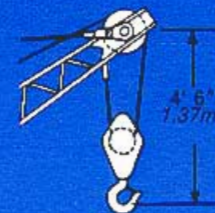

**Auxiliary hoist**  
10.10 tonnes  
single-sheave swivel-hook block



# lifting crane main-boom service notes

## Boom construction

The two-section basic boom is 50' 0" 15,24m long, and comprises a 25' 0" 7,62m lower section and a 25' 0" 7,62m upper section constructed from alloy-steel angles. Boom cross-section 4' 0" 1,22m deep x 4' 6" 1,37m wide.

Intermediate sections 10' 0" 3,05m, 20' 0" 6,10m and 30' 0" 9,14m in length may be inserted to make booms up to 160' 0" 43,77m long. Sections are connected by three-bolt butt-type machined joints.

Knee-type boom safety stops are fitted as standard equipment.

See page 12 for use of fly jibs on booms.

## Working loads

The main-boom working loads listed on pages 10 and 11 for lifting crane service are based on USA rating factors and do not exceed 75% of tipping load with the machine standing on firm, level and uniform supporting surface and without appreciable wind. Loads must be freely suspended. The radii specified are loaded radii and the working loads listed are for booms without fly jibs. Working loads include blocks, hooks, slings and other equipment used in handling loads. Proper care must be exercised by the operator at all times to avoid shock or side loadings on the boom (and jib, when fitted) which might hazard crane stability, particularly when operating with long boom at low angles.

Ratings apply only to machines having booms in first-class condition built and recommended by Ruston-Bucyrus Ltd.

The machine should not be operated outside the tabulated range appropriate to the service and the equipment fitted.

## Working load reduction for jib

The working loads over the main boom sheaves, at any radius, as given on pages 10 and 11, must be reduced in accordance with the following schedule when a jib is fitted (but not in use).

Length of jib	Working load reduction
15' 0" 4,57m	2000 lb 907 kg
30' 0" 9,14m	2600 lb 1220 kg

## Hook blocks

The weight of the hook block in use, together with any slings or other lifting tackle, must be deducted from the working load to arrive at the actual (net) load lifting capacity for any boom length and radius.

Standard equipment for main hoist: 93,5 tonnes triple-sheave swivel-hook block, 3810 lb 1730 kg.

Alternative equipment for main hoist: 41,7 tonnes single-sheave, swivel-hook block 1450 lb 660 kg.

## Boom suspension

All boom lengths are suspended by 10-part rope tackle, 19mm diameter, between the rear-hitch, lowerable A-frame and the floating bridle assembly, and multi-piece pendants, 38mm diameter, between the floating bridle and the boom point.

## Main-load hoist ropes

Standard equipment for all boom lengths: 28mm diameter six-strand (6/19) type with independent wire-rope core.

Optional equipment: 28mm diameter multi-strand (17x26) DYFORM type.

## Main-load hoist-rope loads

Recommended parts of reeving with standard rope and hook block are as follows:

1-part line for loads up to	24 750 lb 11 225 kg
2-part line for loads up to	48 950 lb 22 205 kg
3-part line for loads up to	72 800 lb 33 020 kg
4-part line for loads up to	96 100 lb 43 590 kg
5-part line for loads up to	118 950 lb 53 955 kg
6-part line for loads up to	141 350 lb 64 115 kg
7-part line for all greater loads	

## Load indicators

Standard indicator is of mechanical pendulum type with scales indicating boom angle and also load/radius for a specified boom length.

Additional load/radius scales for alternative boom lengths or boom/jib combinations are available.

A visible and audible automatic load indicator of approved make can be fitted as an optional extra.

Automatic load indicator standard calibration is based on the ratings listed and on the hoist-line reeving specified below.

Boom length	No. of parts main hoist line
50' 0" 15,24m	7
60' 0" 18,29m	6
70' 0" 21,34m	5
80' 0" 24,38m	5
90' 0" 27,43m	4
100' 0" 30,48m	4
110' 0" 33,52m	3
120' 0" 36,57m	3
130' 0" 39,62m	3
140' 0" 42,67m	2
150' 0" 45,72m	2
160' 0" 48,77m	2

# lifting crane

## no fly jib fitted

Length of boom		Operating radius		Equivalent angle of boom	Approximate height of boom-point sheave pin above ground		Capacities based on USA rating factors			
							Maximum counterweight		Bucket service counterweight	
ft	m	ft	m	degrees	ft	m	lb	kg	lb	kg
50	14,24	15	4,57	78	58	17,07	183 800	83 370	154 500	70 080
		20	6,10	73	55	16,76	115 400	52 345	96 700	43 865
		25	7,62	66	53	16,15	83 500	37 815	69 800	31 660
		30	9,14	60	51	15,55	65 000	29 485	54 100	24 540
		35	10,67	54	48	14,63	52 900	23 995	43 900	19 915
		40	12,19	46	43	13,10	44 400	20 140	36 800	16 690
		48	14,63	30	33	10,06	35 100	15 920	28 900	13 110
60	18,29	25	7,62	71	64	19,51	83 000	37 650	69 300	31 435
		30	9,14	66	62	18,90	64 500	29 255	53 600	24 310
		35	10,67	60	59	17,90	52 400	23 770	43 400	19 685
		40	12,19	55	56	17,07	43 900	19 915	36 300	16 465
		50	15,24	42	47	14,32	32 700	14 830	26 800	12 155
		57	17,37	30	38	11,58	27 500	12 475	22 400	10 160
70	21,34	20	6,10	78	76	23,16	114 500	51 935	95 800	43 455
		25	7,62	74	74	22,55	82 500	37 420	68 800	31 205
		30	9,14	70	73	22,25	64 000	29 030	53 100	24 085
		40	12,19	60	68	20,72	43 400	19 685	35 800	16 240
		50	15,24	51	51	18,59	32 300	14 650	26 300	11 930
		60	18,29	39	51	15,55	25 200	11 430	20 400	9 255
		65	19,81	30	44	13,41	22 600	10 250	18 200	8 055
80	24,38	22	6,70	78	86	26,21	98 900	44 860	82 600	37 465
		30	9,14	72	83	25,30	63 700	28 895	52 800	23 950
		40	12,19	65	79	24,08	43 100	19 550	35 400	16 055
		50	15,24	56	74	22,56	31 900	14 470	26 000	11 795
		60	18,29	47	66	20,12	24 900	11 295	20 100	9 115
		70	21,34	36	57	17,37	20 100	9 115	16 000	7 255
		74	22,56	30	48	14,63	18 500	8 390	14 700	6 665
90	27,43	24	7,31	78	95	28,95	86 600	39 280	72 100	32 705
		30	9,14	74	94	28,65	63 100	28 620	52 300	23 725
		40	12,19	68	90	27,43	42 500	19 280	34 900	15 830
		50	15,24	60	85	25,90	31 400	14 245	25 500	11 565
		60	18,29	53	79	24,08	24 300	11 020	19 500	8 845
		70	21,34	44	70	21,34	19 500	8 845	15 500	7 030
		83	25,30	30	53	16,15	15 100	6 850	11 800	5 350
100	30,48	26	7,92	78	105	32,00	76 800	34 835	63 800	28 940
		30	9,14	76	104	31,70	62 700	28 440	51 900	23 540
		40	12,19	70	101	30,79	42 100	19 095	34 500	15 650
		55	16,76	60	94	28,65	27 100	12 290	21 800	9 890
		70	21,34	50	83	25,30	19 100	8 665	15 100	6 850
		80	24,38	42	74	22,56	15 600	7 075	12 100	5 490
		91	27,74	30	59	17,98	12 700	5 760	9 650	4 375
110	33,52	28	8,53	78	115	35,05	68 800	31 205	57 000	25 855
		40	12,19	72	112	34,14	41 800	18 960	34 200	15 515
		50	15,24	66	108	32,92	30 600	13 880	24 700	11 205
		60	18,29	60	103	31,39	23 800	10 705	18 800	8 535
		80	24,38	47	88	26,82	15 300	6 940	11 800	5 350
		90	27,43	40	77	23,47	12 600	5 715	9 500	4 310
		100	30,48	30	63	19,20	10 500	4 760	7 750	3 515

# main-boom ratings

Length of boom		Operating radius		Equivalent angle of boom degrees	Approximate height of boom-point sheave pin above ground		Capacities based on USA rating factors	
ft	m	ft	m		ft	m	Maximum counterweight lb	kg
120	36.57	30	9.14	78	125	38.10	61 900	28 075
		40	12.19	73	122	37.19	41 300	18 735
		50	15.24	68	119	36.27	30 100	13 655
		60	18.29	63	114	34.75	23 100	10 480
		70	21.34	58	108	32.92	18 300	8300
		90	27.43	45	92	28.04	12 000	5445
		100	30.48	38	81	24.69	9950	4515
130	39.62	33	10.06	78	134	40.84	53 700	24 360
		40	12.19	75	133	40.54	40 900	18 550
		50	15.29	70	129	39.32	29 700	13 470
		70	21.34	60	120	36.58	17 800	8075
		90	27.43	50	106	32.31	11 700	5305
		100	30.48	43	96	29.26	9550	4330
140	42.67	35	10.67	78	144	43.89	49 100	22 270
		40	12.19	76	143	43.59	40 600	18 415
		50	15.24	72	140	42.67	29 400	13 335
		70	21.34	63	131	39.93	17 500	7940
		90	27.43	53	119	36.27	11 300	5125
		100	30.48	48	110	33.53	9200	4175
150	45.72	37	11.28	78	154	36.97	44 700	20 275
		40	12.19	77	153	36.66	39 900	18 100
		50	15.24	73	151	36.05	28 700	13 020
		60	18.29	69	147	34.83	21 700	9845
		80	24.38	60	138	32.09	13 300	6030
		100	30.48	51	124	37.82	4550	3880
160	48.77	39	7.01	78	164	50.02	41 000	18 595
		50	15.24	74	161	49.10	28 300	12 835
		60	18.29	70	158	48.19	21 300	9660
		70	21.34	66	154	46.91	16 500	7485
		80	24.38	62	149	34.34	13 000	5895
		100	30.48	54	137	41.78	8150	3695
		120	36.57	44	119	36.29	5050	2290

For service notes see page 9

# lifting crane fly-jib service notes

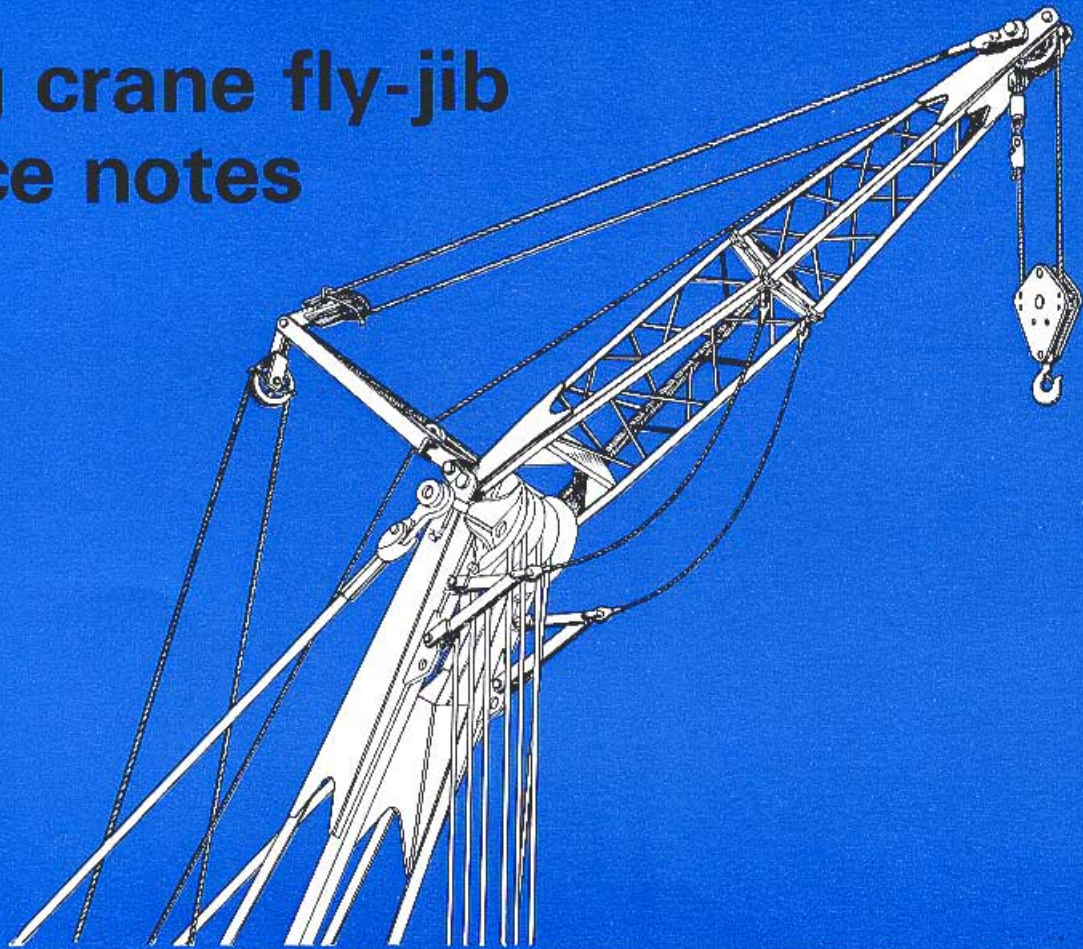

## Jib construction

Jibs are of all-welded lattice construction with alloy-steel angle-type chord members and mild-steel lacing members. Basic length of jib is 15' 0" 4,57m comprising 7' 6" 2,28m upper and lower sections with three-bolt butt-type machined joints between the sections.

Jib cross section 1' 6" 457mm deep x 2' 0" 610mm wide.

An intermediate section 15' 0" 4,57m in length is available to enable a maximum jib length of 30' 0" 9,14m to be obtained.

## Jib service notes

Jibs are designed for load lifting purposes only and are not suitable for dragline or grabbing crane operation.

Jibs may only be used at 20° offset to the centre-line of the main boom.

All permissible combinations of boom and jib are given on page 13 and the machine should not be operated outside the tabulated range appropriate to the service and the equipment fitted.

## Working loads

Jib working loads listed on page 13 are applicable to machines fitted with 10-part boom-suspension tackle and lifting crane counterweight.

Working loads are given in terms of boom/jib lengths and boom angles but must not exceed 22 400 lb 10 160 kg with 15' 0" 4,57m jib and 13 500 lb 6120 kg with 30' 0" 9,14m jib.

Working loads are based on USA rating factors and do not exceed 75% of tipping load and are for a machine standing on firm, level ground.

The weight of the hook in use, together with any slings or other lifting tackle, must be deducted from the working load to arrive at the actual (net) load capacity for any jib length and radius.

Standard equipment: 10,16 tonnes single-sheave swivel-hook block 360 lb 163 kg.

1-part line for loads up to 18 500 lb 8390 kg

2-part line for all greater loads.

## Jib hoist rope

22mm diameter multi-strand (17 x 19) DYFORM type.

Two-part auxiliary hoist line is standard for all 15' 0" 4,57m jib combinations; single-part hoist line is standard for 30' 0" 9,14m combinations. Calibration of visible and audible safe-load indicator (when fitted) is based on the appropriate standard reeving.

# lifting crane fly-jib ratings

	Length of main boom		Angle of main boom degrees	Working load over jib sheave		Jib load radius		Approximate height of jib point	
	ft	m		lb	kg	ft	m	ft	m
<b>15 ft 4,57m fly jib</b>  93,5 tonnes main hook block fitted to main hoist	80	24,38	76	22 400	10 160	33	10,06	98	29,87
			72	22 400	10 160	40	12,19	96	29,26
			66	22 000	9980	50	15,24	91	27,74
			58	21 000	9520	60	18,29	86	25,91
			47	16 600	7530	74	22,55	73	22,25
	90	27,43	78	22 400	10 160	36	10,97	108	32,92
			74	22 400	10 160	45	13,71	107	32,62
			68	22 000	9980	50	15,24	102	31,09
			62	21 000	9520	60	18,29	97	29,57
			45	17 700	8030	70	21,34	90	27,43
	100	30,48	76	22 400	10 160	38	11,58	118	35,97
			70	22 000	9980	50	15,24	113	34,44
64			21 000	9520	60	18,29	109	33,22	
59			17 200	7800	70	21,34	102	31,09	
45			13 600	6170	80	24,38	95	28,96	
110	33,53	76	22 400	10 160	41	12,49	127	38,71	
		67	22 000	9980	60	18,29	120	36,58	
		61	18 300	8300	70	21,34	114	34,75	
		56	14 700	6670	80	24,38	108	32,92	
		43	11 900	5400	90	27,43	99	30,18	
120	36,58	76	22 400	10 160	43	13,10	137	41,76	
		89	21 500	9750	60	18,29	131	39,93	
		64	17 800	8070	70	21,34	126	38,41	
		59	14 200	6440	80	24,38	120	36,58	
		48	11 400	5170	90	27,43	112	34,11	
130	39,62	76	22 400	10 160	46	14,02	147	44,80	
		70	21 100	9570	60	18,29	142	43,28	
		66	17 400	7890	70	21,34	137	41,76	
		61	13 800	6260	80	24,38	132	40,23	
		46	11 000	4990	90	27,43	125	38,10	
140	42,67	76	22 400	10 160	48	14,63	158	47,55	
		71	20 800	9430	60	18,29	152	46,33	
		67	17 100	7760	70	21,34	148	45,11	
		63	13 500	6220	80	24,38	143	43,59	
		50	10 700	4850	90	28,43	137	41,76	
30 ft 9,14m fly jib	80	24,38	76	13 500	6120	42	12,80	111	33,83
			72	12 000	5440	50	15,24	107	32,62
			66	11 500	5220	60	18,29	102	31,09
			57	10 200	4630	74	22,55	93	28,35
			76	13 500	6120	44	13,41	120	37,58
90	27,43	73	12 000	5440	50	15,24	118	35,97	
		68	11 800	5350	60	18,29	114	34,75	
		62	11 100	5030	70	21,34	108	32,92	
		56	10 200	4630	83	25,30	98	29,87	
		76	13 500	6120	47	14,32	130	39,62	
100	30,48	70	12 000	5440	60	18,29	126	38,10	
		65	11 700	5310	70	21,34	119	36,27	
		60	11 000	4990	80	24,38	113	34,44	
		53	10 300	4670	91	27,74	104	31,70	
		76	13 500	6120	49	14,93	140	42,67	
110	33,53	67	12 400	5620	70	21,34	131	39,93	
		62	11 600	5260	80	24,38	125	38,10	
		67	10 800	4900	90	27,43	118	35,97	
		62	10 300	4670	100	30,48	110	33,53	
		76	13 500	6120	52	15,85	149	45,41	
120	36,58	69	12 600	5710	70	21,34	142	43,28	
		64	11 800	5350	80	24,38	137	41,76	
		60	11 000	4990	90	27,43	130	39,62	
		55	10 200	4630	100	30,48	123	37,49	
		76	13 500	6120	54	16,46	159	48,46	
130	39,62	66	12 000	5440	80	24,38	148	45,11	
		62	11 200	5080	90	27,43	142	43,28	
		67	9800	4440	100	30,48	136	41,15	
		63	8000	3630	110	33,53	127	38,71	
		76	13 500	6120	54	16,46	159	48,46	

For service notes see opposite

# dragline and grabbing crane working ranges

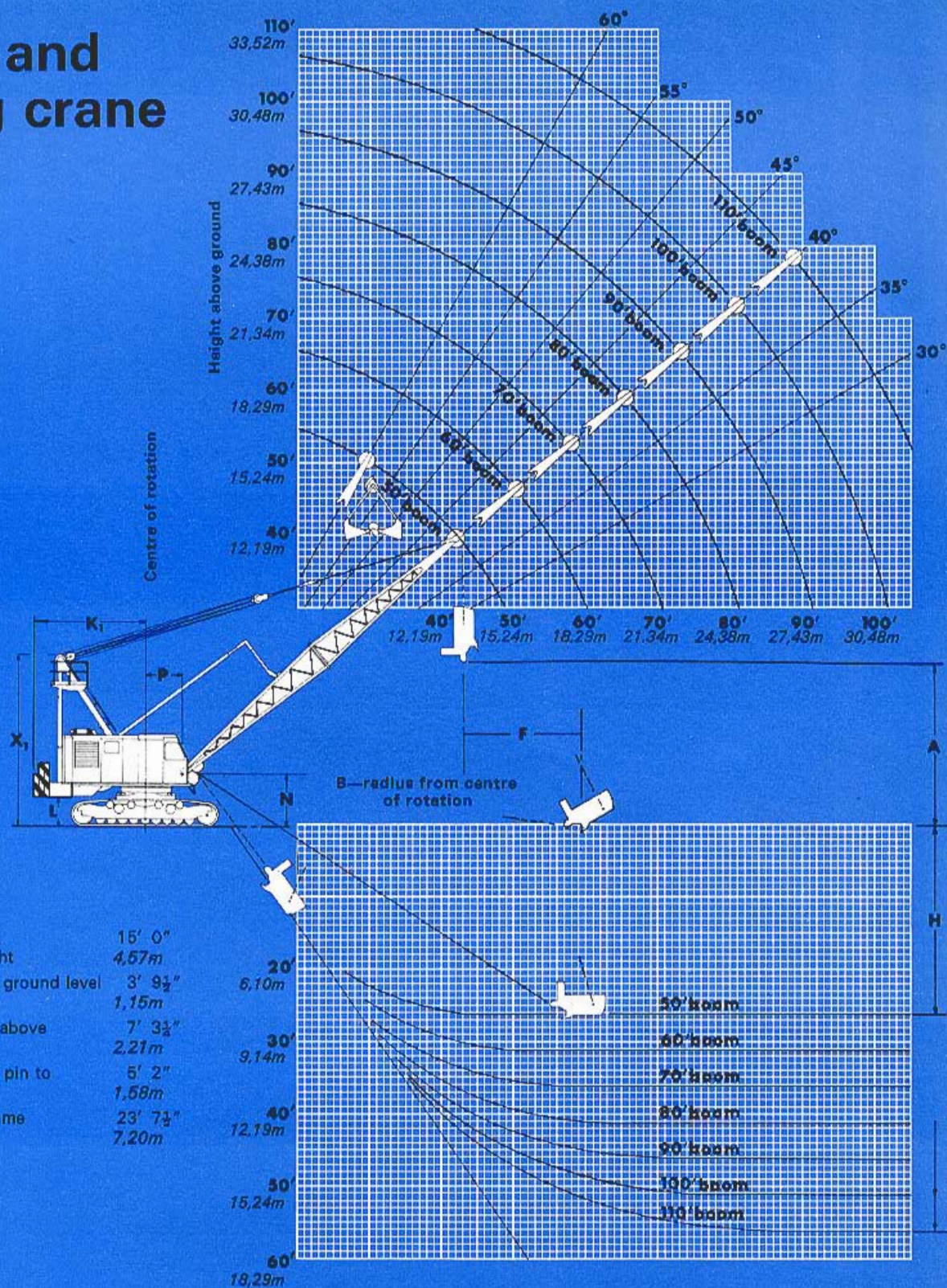

K <sub>1</sub>	Clearance radius over external rear counterweight	15' 0"	4,57m
L	Clearance under frame to ground level	3' 9½"	1,15m
N	Height of boom-foot pin above ground level	7' 3½"	2,21m
P	Distance from boom-foot pin to centre of rotation	5' 2"	1,58m
X <sub>1</sub>	Height over erected A-frame	23' 7½"	7,20m

A Dumping height  
 B Dumping radius  
 F Throw of bucket beyond boom point  
 H Digging depth below ground level

Depth shown on diagram is with standard ropes; one wrap on drum and boom in position indicated—depths for other boom positions may be determined by striking equal arcs from the proposed location of boom-point pin.

Equal to the height of the boom-point pin, less vertical dimension R given in the tables on pages 16 & 17. Approximately the same as the operating radius—see ratings table on page 15.

For a dragline this dimension, usually one-third to one-half of boom length, depends upon the ability of the operator, length of boom, height of boom head, depth of excavation and weight of bucket.

**Dragline**  
 Half operating radius B is a fair average; actual depth depends on character of material and conditions. It is possible when working conditions are unusually favourable and by using suitable ropes, to reach a depth equal to the operating radius.

**Grabbing crane**  
 Digging depth for grabbing crane, using standard ropes, is approximately 8' 0" 2,44m greater than indicated for dragline.

# dragline and grabbing crane ratings

Length of boom		Operating radius		Equivalent angle of boom	Approximate height of boom-point sheave pin above ground		Capacities based on USA rating factors			
							Dragline working load		Grabbing crane or magnet crane working load	
ft	m	ft	m	degrees	ft	m	lb	kg	lb	kg
50	15,24	30	9,14	60	51	15,55	20 800*	9435	22 500†	10 200
		40	12,19	46	43	13,11	20 800*	9435	22 500†	10 200
		48	14,63	30	33	10,06	20 800*	9435	22 500†	10 200
60	18,29	35	10,67	60	59	17,99	20 800*	9435	22 500†	10 200
		40	12,19	55	56	17,08	20 800*	9435	22 500†	10 200
		52	15,86	39	45	13,72	20 800*	9435	22 500†	10 200
		55	16,77	34	41	12,50	20 800*	9435	21 250	9640
70	21,34	57	17,37	30	38	11,59	20 800*	9435	20 240	9180
		40	12,19	60	68	20,74	20 800*	9435	22 500†	10 200
		50	15,24	51	61	18,60	20 800*	9435	22 500†	10 200
		52	15,86	48	60	18,29	20 800*	9435	22 500†	10 200
		55	16,77	45	57	17,38	20 800*	9435	20 800	9430
80	24,38	59	17,99	40	52	15,86	20 800*	9435	18 850	8550
		65	19,82	30	44	13,42	18 250	8280	16 420	7450
		45	13,72	60	77	23,48	20 800*	9435	22 500†	10 200
		50	15,24	56	74	22,57	20 800*	9435	22 500†	10 200
		51	15,55	55	73	22,26	20 800*	9435	22 500†	10 200
90	27,43	58	17,69	49	68	20,74	20 800*	9435	18 990	8610
		65	19,82	42	61	18,60	17 890	8115	16 100	7300
		74	22,57	30	48	14,64	14 740	6685	13 270	6020
		50	15,24	60	85	25,92	20 800*	9435	22 500†	10 200
		57	17,37	55	81	24,70	22 800*	9435	18 990	8610
100	30,48	60	18,29	53	79	24,09	19 560	8870	17 600	7985
		70	21,34	44	70	21,34	15 490	7025	13 940	6320
		83	25,31	30	53	16,16	11 790	5345	10 610	4810
		55	16,77	60	94	28,67	20 800*	9435	19 630	8900
		56	17,08	59	93	28,36	20 800*	9435	19 120	8760
110	33,52	70	21,34	50	83	25,31	15 080	6840	13 580	6160
		80	24,38	42	74	22,57	12 120	5495	10 910	4950
		91	27,75	30	59	17,99	9660	4380	8700	3950
		60	18,29	60	103	31,41	18 830	8540	16 950	7690
		70	21,34	54	96	29,28	14 760	6695	13 280	6020
110	33,52	80	24,38	47	88	26,84	11 790	5345	10 610	4810
		90	27,43	40	77	23,48	9530	4320	8580	3890
		100	30,48	30	63	19,21	7750	3515	6980	3170

## service notes

### General

Maximum length of boom for bucket service is 110' 0" 33,52m. Loads must be reduced when operating on soft or uneven ground, for bucket suction, or other unfavourable operating conditions.

Boom angles greater than 60 degrees or less than 30 degrees are not recommended for bucket service, and the machine should not be operated outside the tabulated range appropriate to the service and the equipment fitted.

### Booms

The basic length is 50' 0" 15,24m comprising a 25' 0" 7,62m lower section and a 25' 0" 7,62m upper section with three-bolt butt-type machined joints, and this can be extended to a maximum of 110' 0" 33,52m for bucket service by the insertion of appropriate intermediate sections.

Multi-piece pendant type suspension is standard for all boom lengths; 10-part rope 19mm diameter between the rear-hitch lowerable A-frame and the floating bridle. Pendants 38mm diameter.

### Dragline service

Working loads listed above are based on USA rating factors and do not exceed 75% of tipping load for the machine when standing on firm and level ground with the boom in the least favourable position.

\*Listed working loads represent the weight of the bucket and contents, which must not exceed 20 800 lb 9435 kg.

Knee-type boom-safety stops may be fitted as optional equipment.

### Grabbing (or magnet) crane service

Working loads listed above are based on USA rating factors and do not exceed 68% of tipping load for the machine when standing on firm and level ground with the boom in the least favourable position.

†Listed working loads represent the weight of grab and contents (or magnet and load), which must not exceed 22 500 lb 10 200 kg.

Knee-type boom-safety stops are fitted as standard equipment.

# dragline buckets

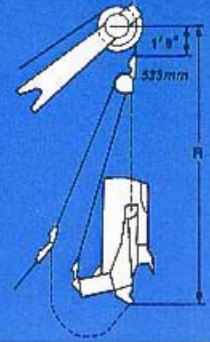

Type		BAX	'Lincoln'						
Capacity	cubic yards <i>litres</i>	4½ 3440	4* 3055	3½* 2675	3* 2290	2½ 1910	2 1530	1½ 1350	1½ 1150
Weight empty	lb <i>kg</i>	7700 3495	7450 3380	7000 3175	6565 2990	4700 2130	4250 1925	3300 1495	2900 1315
Vertical dimension R		20' 3" 6.17m	20' 11" 6.37m	20' 3" 6.17m	20' 1" 6.12m	18' 1" 5.52m	17' 11" 5.46m	15' 7½" 4.76m	15' 3" 4.65m
Material	Weight lb per cubic yard <i>kg per cubic metre</i>	Suspended load—weight of bucket and contents							
Earth—moist	2500 1490	18 950 8585	17 450 7915	15 750 7145	14 065 6380	10 950 4965	9250 4195	7675 3480	6650 3015
Sand—dry	2700 1600	19 850 8990	18 250 8280	16 450 7460	14 665 6650	11 450 5190	9650 4375	8025 3640	6950 3150
Sand—wet	3300 1960	22 550 10 215	20 650 9220	18 550 8415	16 465 7470	12 950 5875	10 850 4920	9075 4115	7850 3560
Gravel	2900 1720	20 750 9400	19 050 8640	17 150 7780	15 265 6925	11 950 5420	10 050 4550	8375 3795	7250 3290
Loose stone	2700 1600	19 850 8990	18 250 8280	16 450 7460	14 665 6650	11 450 5190	9650 4375	8025 3640	6950 3150
Clay—wet	3000 1780	21 200 9605	19 450 8820	17 500 7940	15 565 7060	12 200 5535	10 250 4650	8550 3875	7400 3355
Coal	1350 800	13 775 6420	12 850 5830	11 725 5320	10 615 4815	8075 3660	6950 3150	5660 2565	4920 2230

\* Weights given above are with forged steel chains.

When cast chains are fitted, a reduction of 200 lb 91kg should be made.



# medium-weight grabs

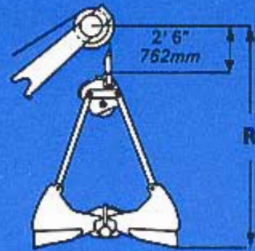

Heaped



15° (C.E.C.E. rating)

Capacities given are heaped and 15° (C.E.C.E. rating) see diagrams

Capacity	cubic feet	100/80	90/72	80/64	71/57	63/51	50/40	44/35
	litres	2750/ 2250	2500/ 2000	2250/ 1750	2000/ 1600	1750/ 1500	1500/ 1100	1250/ 1000
Weight empty	lb	6650	5200	5100	3900	3850	3050	2950
	kg	2975	2400	2350	1800	1750	1375	1350
Vertical dimension R		14' 6"	13' 8"	13' 5"	12' 7"	12' 6"	11' 6"	11' 4"
		4,42m	4,17m	4,09m	3,83m	3,81m	3,50m	3,46m
Material	Weight lb per cubic yard kg per cubic metre	Suspended load—weight of bucket and contents						
Earth—moist	2500	15 800/ 13 950	13 520/ 11 870	12 500/ 11 010	10 470/ 9080	9675/ 8570	7675/ 6750	7110/ 6190
	1490	7165/ 6330	6135/ 5385	5670/ 4995	4750/ 4120	4390/ 3890	3480/ 3060	3225/ 2810
Sand/dry	2700	16 550/ 14 550	14 200/ 12 400	13 100/ 11 500	11 000/ 9600	10 150/ 8950	8050/ 7050	7350/ 6450
	1600	7505/ 6600	6440/ 5625	4940/ 5215	4990/ 4355	4605/ 4060	3650/ 3200	3335/ 2925
Sand—wet	3300	18 750/ 16 320	16 200/ 14 000	14 880/ 12 920	12 580/ 10 870	11 550/ 10 080	9160/ 7950	8330/ 7230
	1960	8505/ 7405	7350/ 6350	6750/ 5860	4705/ 4930	5240/ 4570	4155/ 3605	3780/ 3280
Gravel	2900	17 300/ 15 150	14 860/ 12 930	13 700/ 11 980	11 520/ 10 020	10 520/ 9320	8420/ 7350	7670/ 6710
	1720	7845/ 6870	6740/ 5865	6215/ 5435	5225/ 4545	4815/ 4225	3820/ 3335	3480/ 3045
Loose stone	2700	16 550/ 14 550	14 200/ 12 400	13 100/ 11 500	11 000/ 9600	10 150/ 8950	8050/ 7050	7350/ 6450
	1600	7505/ 6600	6440/ 5625	5940/ 5215	4990/ 4355	4605/ 4060	3650/ 3200	3335/ 2925
Clay—wet	3000	17 650/ 15 430	15 200/ 13 200	13 980/ 12 210	11 790/ 10 230	10 850/ 9520	8610/ 7490	7840/ 6840
	1740	8005/ 6200	6895/ 5985	6340/ 5540	5350/ 4640	4920/ 4320	3905/ 3395	3555/ 3105
Coal	1350	11 550/ 10 550	9700/ 8800	9100/ 8300	7450/ 6750	7000/ 6400	5605/ 5050	5150/ 4700
	800	5240/ 4785	4400/ 3990	4130/ 3765	3380/ 3060	3175/ 2905	2515/ 2290	2335/ 2130
Coke	850	9690/ 9070	8030/ 7470	7620/ 7120	6130/ 5690	5830/ 5450	4620/ 4310	4350/ 4050
	505	4395/ 4115	3640/ 3390	3455/ 3230	2780/ 2580	2645/ 2470	2095/ 1955	1970/ 1835

Note: Data given for medium-weight rehandling grabs.

Additional sizes and types, e.g., coal, general-purpose, excavating, etc., are available to suit duties.

# unit dimensions and weights

(for transportation)

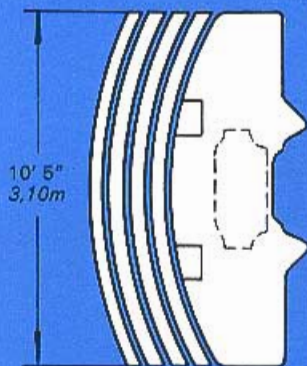

**Rear-end casting**  
 10' 5" 3,10m long  
 4' 3" 1,30m wide  
 3' 1" 940mm deep

**Counterweights (4 pieces)**  
 10' 5" 3,18m long  
 3' 8" 1,12m wide  
 4' 8" 1,42m deep  
 3  
 10' 5" 3,18m long  
 3' 8" 1,12m wide  
 3' 4" 1,02m deep  
 1

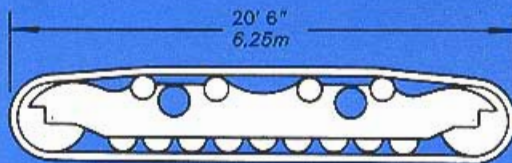

**Crawler side-frame assembly**

20' 6" 6,25m long  
 5' 8½" 1,73m wide  
 3' 8" 1,12m deep

**Truck frame, swing circle and axles**

13' 10¼" 4,24m long  
 8' 7" 2,62m wide  
 4' 6½" 1,38m deep

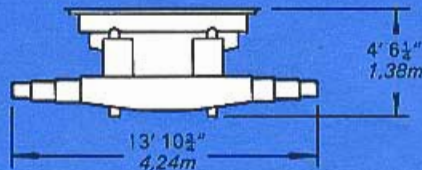

**Rear-hitch A-frame**  
 See page 6 for folded arrangement

**Superstructure**

18' 5" 5,61m long  
 10' 6" 3,20m wide  
 8' 10" 2,69m deep

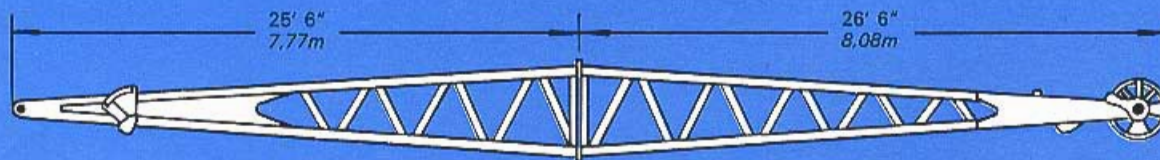
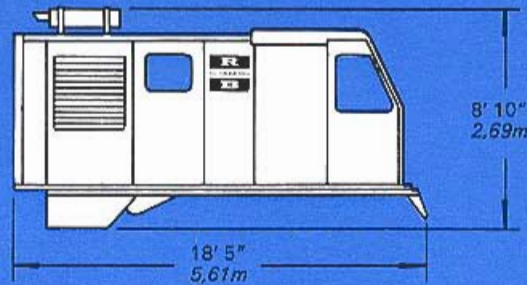

**UNIT WEIGHTS (approximate)**

Boom : upper section	5050 lb	2290 kg
lower section	4640 lb	2105 kg
Intermediate section (not illustrated)		
10' 3,05m long	1180 lb	535 kg
20' 6,10m long	2100 lb	950 kg
30' 9,14m long	3050 lb	1385 kg
Superstructure	54 420 lb	24 685 kg
"A" frame	6610 lb	3000 kg
Hook block	3810 lb	1730 kg
Rear-end casting	22 230 lb	10 085 kg
Counterweight—three at 9500 lb 4310 kg and one at 6500 lb 2950 kg	35 000 lb	15 880 kg
Truck frame	16 460 lb	7465 kg
Axles—two (5500 lb 2500 kg each)	11 000 lb	5000 kg
Crawler side-frame assemblies (each 26 100 lb 11 840 kg)	52 200 lb	11 840 kg

**Boom**

4' 6" 1,37m wide  
 4' 0" 1,22m deep



**Hook block**

7' 6" 2,29m high  
 3' 4½" 1,03m wide  
 2' 5½" 750mm deep



## **RUSTON-BUCYRUS LIMITED**

Lincoln, England LN6 7DJ

Telephone: 0522 25261    Telegrams: Bucyruston Lincoln    Telex: 56191

Subsidiary of Bucyrus-Erie Company, South Milwaukee, Wisconsin 53172, U.S.A.

Represented in most parts of the world

*Although every care is taken in the preparation of this publication, which cancels all previous editions, the illustrations, specifications, weights and dimensions must not be taken as binding until confirmed.*

*While all dimensions are set out as accurately as possible, due allowance must be made in relating certain operating dimensions to practical field applications.*

*The metric figures in this publication are approximate.*

*It is the policy of Ruston-Bucyrus Limited to improve its products continually and, in accordance with this policy or because of the unavailability of materials, alterations may be necessary from time to time.*

*Any variation from the standard specification may involve increase in price and extended delivery.*