

LIEBHERR
FASTOWER

66K

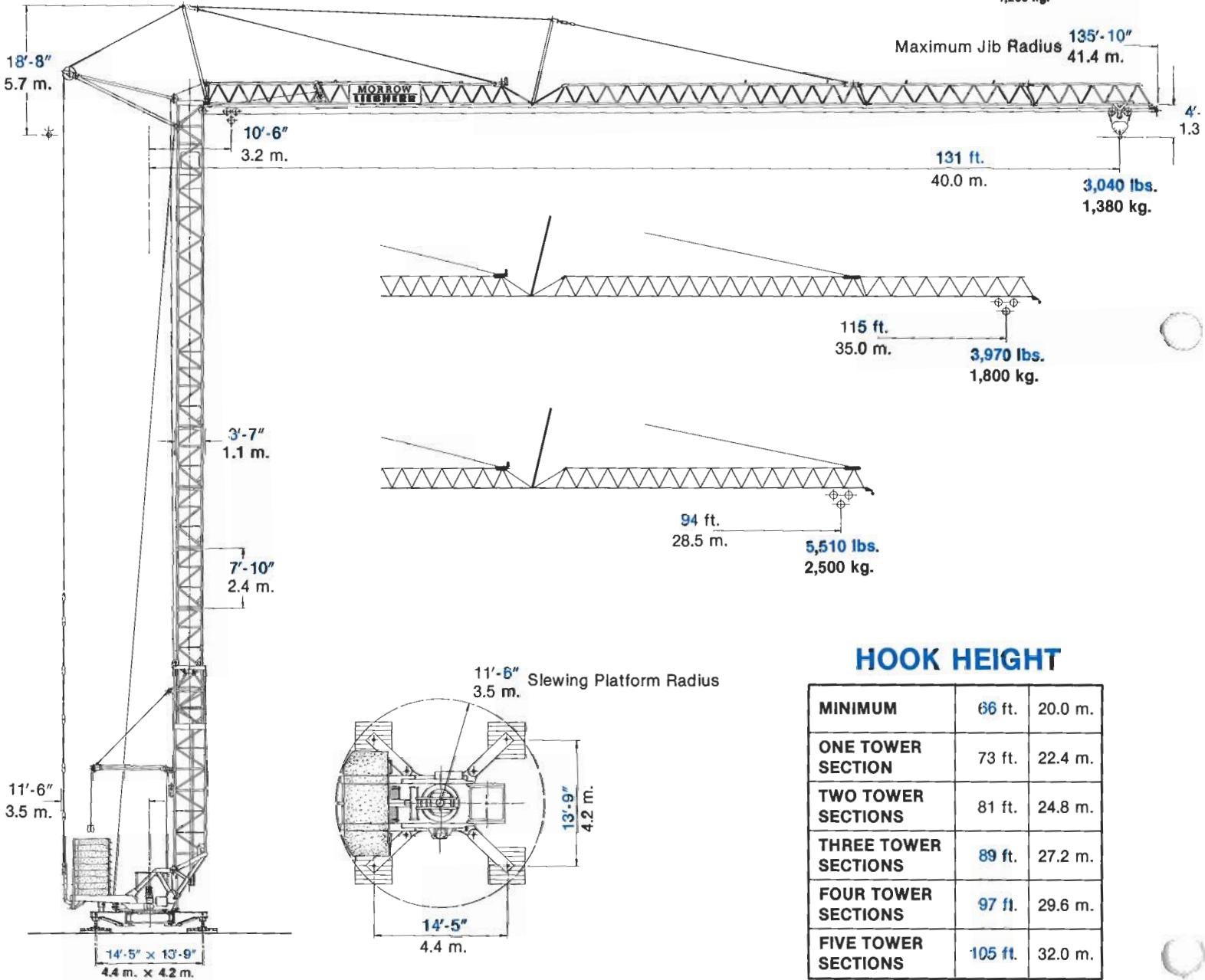

66 K

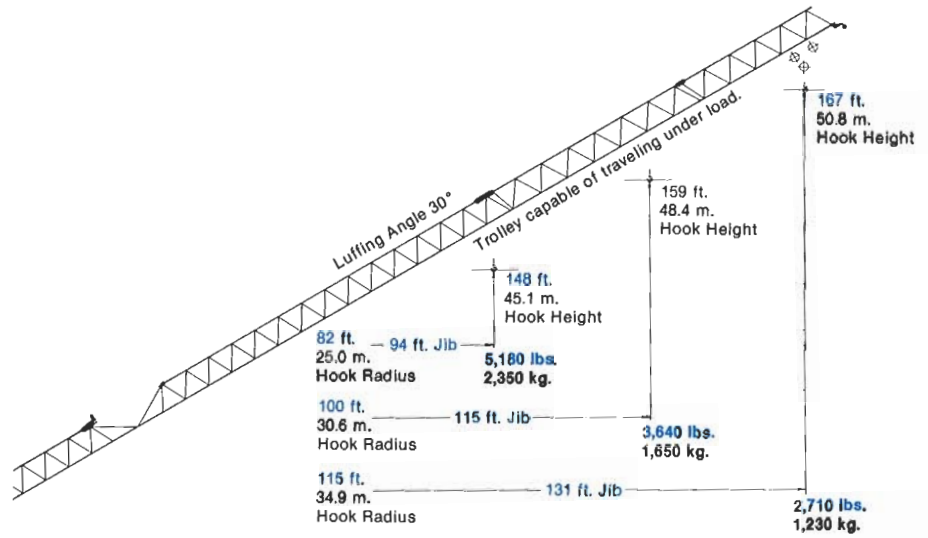

HOOK HEIGHT

MINIMUM	66 ft.	20.0 m.
ONE TOWER SECTION	73 ft.	22.4 m.
TWO TOWER SECTIONS	81 ft.	24.8 m.
THREE TOWER SECTIONS	89 ft.	27.2 m.
FOUR TOWER SECTIONS	97 ft.	29.6 m.
FIVE TOWER SECTIONS	105 ft.	32.0 m.

Stationary
(on outriggers)

Plan View — showing slewing platform radius and outriggers deployed on pads.

Mobile . . . Self-erecting . . . Efficient . . . Economical.

Built to excel on small to mid-sized construction and materials handling jobs. Loaded with cost-reducing features. That's the new FasTower crane by Liebherr. And they've been proving themselves for years on job sites around the world. Now they are available in North America from Morrow Crane Company on an immediate delivery basis.

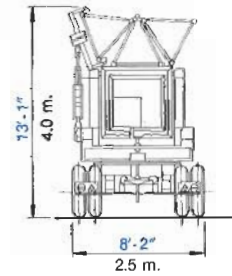
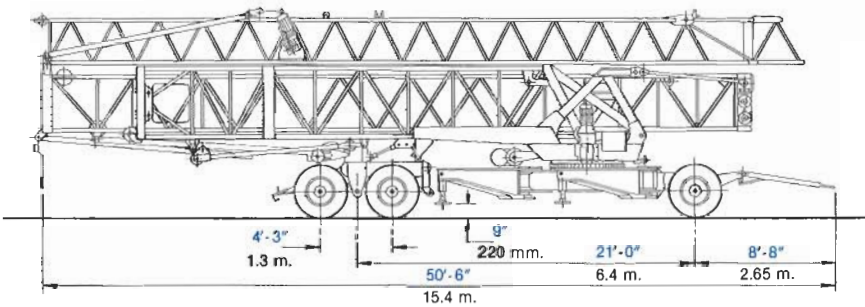

Transporter
(3-Axle unit without counterweights)

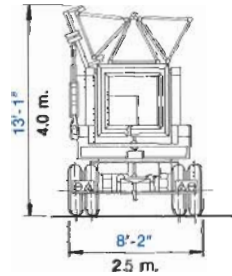
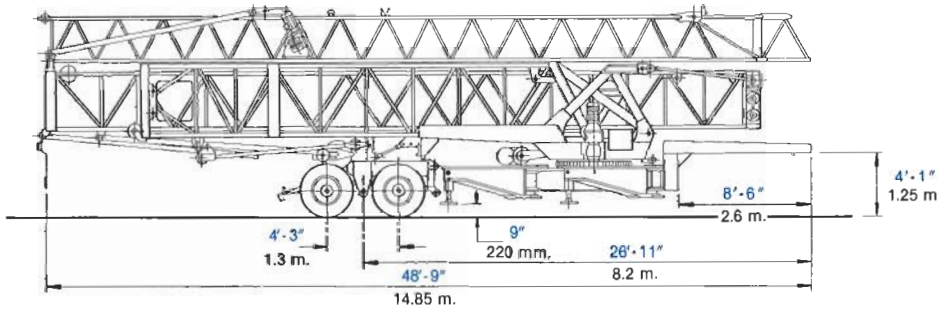

Transporter
(Fifth wheel unit without counterweights)

OPTIONAL UNDERCARRIAGES

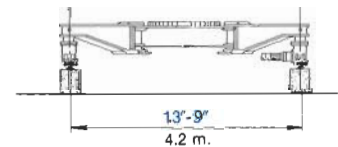
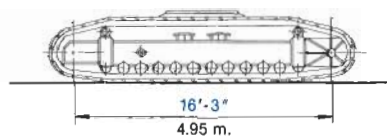
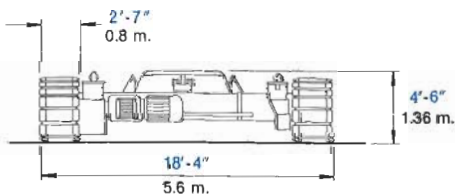

Crawler

Rail Traveling

LIEBHERR MODEL 66 K

RADIUS AND CAPACITIES

HOOK RADIUS ft. m.	MAXIMUM CAPACITIES ft. lbs. m. kg.		2-PART LINE												
			ft. m.	75 22.9	80 24.4	85 25.9	90 27.4	94 28.5	100 30.5	105 32.0	110 33.5	115 35.0	120 36.6	125 38.1	131 40.0
131 40.0	80.0 5,510	24.4 2,500	lbs. kg.	5,510 2,500	5,510 2,500	5,140 2,330	4,805 2,180	4,585 2,080	4,245 1,925	3,990 1,810	3,915 1,775	3,570 1,620	3,380 1,535	3,230 1,465	3,040 1,380
115 35.0	87.2 5,510	26.6 2,500	lbs. kg.	5,510 2,500	5,510 2,500	5,510 2,500	5,325 2,415	5,070 2,300	4,685 2,125	4,410 2,000	4,355 1,975	3,970 1,800			
94 28.5	94.0 5,510	28.5 2,500	lbs. kg.	5,510 2,500	5,510 2,500	5,510 2,500	5,510 2,500	5,510 2,500							

HOOK RADIUS ft. m.	MAXIMUM CAPACITIES ft. lbs. m. kg.		4-PART LINE														
			ft. m.	40 12.2	50 15.2	60 18.3	70 21.3	80 24.4	90 27.4	94 28.5	100 30.5	105 32.0	110 33.5	115 35.0	120 36.6	125 38.1	131 40.0
131 40.0	43.6 11,025	13.3 5,000	lbs. kg.	11,025 5,000	9,265 4,200	7,335 3,330	6,055 2,745	5,095 2,310	4,375 1,985	4,165 1,890	3,815 1,730	3,570 1,620	3,375 1,530	3,175 1,440	3,000 1,360	2,835 1,285	2,645 1,200
115 35.0	48.9 11,025	14.9 5,000	lbs. kg.	11,025 5,000	10,890 4,940	8,515 3,865	7,030 3,190	5,945 2,695	5,130 2,325	4,870 2,210	4,485 2,035	4,210 1,910	3,970 1,800	3,750 1,700			
94 28.5	51.8 11,025	15.8 5,000	lbs. kg.	11,025 5,000	11,025 5,000	9,200 4,175	7,615 3,455	6,435 2,920	5,565 2,525	5,290 2,400							

JIB LENGTH ft. m.	HOOK RADIUS ft. m.	MAXIMUM CAPACITIES ft. lbs. m. kg.		2-PART LINE • JIB LUFFED 30°														
				ft. m.	70 21.3	76 23.2	82 25.0	85 25.9	88 26.8	91 27.7	94 28.7	97 29.6	100 30.6	103 31.4	106 32.3	109 33.2	112 34.1	115 35.0
131 40.0	115 35.0	69.9 5,180	21.3 2,350	lbs. kg.	5,160 2,340	4,675 2,120	4,235 1,920	4,035 1,830	3,860 1,750	3,680 1,670	3,525 1,600	3,375 1,530	3,240 1,470	3,110 1,410	3,000 1,360	2,890 1,310	2,800 1,270	2,710 1,230
115 35.0	100 30.6	76.4 5,180	23.3 2,350	lbs. kg.	5,180 2,350	5,180 2,350	4,740 2,150	4,520 2,050	4,320 1,960	4,125 1,870	3,945 1,790	3,790 1,720	3,640 1,650					
94 28.5	82 25.0	82.0 5,180	25.0 2,350	lbs. kg.	5,180 2,350	5,180 2,350	5,180 2,350											

WEIGHT SPECIFICATIONS*

Transporter weight (3-axle unit) (without counterweight)	53,500 lbs./24,275 kg.	Dead weight (without counterweight)	46,200 lbs./20,950 kg.
Transporter weight (5th wheel unit) (without counterweight)	51,600 lbs./23,425 kg.	Counterweight (9 slabs)	57,300 lbs./26,000 kg.
Maximum corner pressure (in operation)	72,400 lbs./32,850 kg.	Tower sections (each)	1,000 lbs./450 kg.

*Weights are approximate. Specific information available from Morrow Crane Co., Inc.

Specifications

HOIST SPEED AND CAPACITY

HOIST UNIT	2-PART LINE						
	MOTOR SPEED	SPEED feet/minute		CAPACITY pounds	SPEED meters/minute		CAPACITY kilograms
24 HP 18 kW AC Hoist Unit Pole Changing (3-Speed) Electromagnetic Brake	1	26	@	5,510	8.0	@	2,500
	2	115	@	5,510	35.0	@	2,500
	3	236	@	2,975	72.0	@	1,350
	4-PART LINE						
	1	13	@	11,025	4.0	@	5,000
	2	58	@	11,025	17.5	@	5,000
3	118	@	4,960	36.0	@	2,250	

TROLLEY

DRIVE UNIT	SPEED
4.0 hp 3.0 kW	36/148 ft./min. 11.0/45.0 m./min.

SWING

DRIVE UNIT	SPEED
5.0 hp 3.75 kW Fluid Coupling	0.8 rpm

TRAVELING

DRIVE UNIT	SPEED
2 × 3.0 hp 2 × 2.2 kW	98 ft./min. 30.0 m./min.

POWER REQUIREMENTS

440 volts, 3-phase, 60-cycle, 75 amp. service.

DO NOT exceed 460 volts.