

Grove GBT35

Product Guide



Features

- 38,7 m five-section boom
- 35 t rating
- Self-lubricating Easy Glide wear pads
- 2041 kg tailswing counterweight

Features



Outriggers

Outrigger span of 7,52 m when fully extended; 5,33 m at mid-span.

Equipped with both ground level and in-cab outrigger controls, the GBT35 outriggers allow quick and easy crane set-up and can be positioned at 0%, 50% and 100%.



Overload protection

All Grove boom trucks are equipped with overload protection. A Load Moment Indicator (LMI) is standard on all GBT35 machines. The LCD display is visible in full or low light and displays all crane load lifting values simultaneously. Includes Work Area Definition System (WADS).

Five-section boom

At 38,71 m, the GBT35 five-section boom is the longest in its size range. The long boom allows the operator to perform more lifts without the use of a jib, reducing setup time and improving efficiency.

Introducing the GBT35

- 35,0 t maximum capacity
- 41,15 m maximum tip height (main boom)
- 57,61 m maximum tip height (boom with jib)

Deluxe operator's cab

Rigid galvanized steel structure, well insulated, with tinted safety glass for operator visibility and comfort. Multi-position seat with arm rest mounted single axis controls, ventilation fans, diesel heater, dual cab mounted worklights and wipers. Optional air conditioning is available.



Features

Grove is proud to introduce the GBT35 crane

Comfort:

- Easy Glide Boom wear pads reduces the vibration
- State the art control valves provides smoother operation

Versatility:

- Largest boom that allows to use the crane for multiple jobsites cranes

Transport:

- No road permit needed
- Turntable lock to secure superstructure for travel

Longevity:

- Rust reduced thanks to painting crane components before assembly
- Booms section are supported by one hydraulic extend cylinder, minimizing maintenance



Contents

Specifications	5
Dimensions	8
Working range	9
Load charts	10

Specifications

Superstructure



Boom

9,45m – 38,7m. Five-section, 5-section, 4-plate construction, full-power boom. Integral holding valve on the telescope cylinder. Three (3) quick reeve cast iron sheaves in the main boom nose.

Maximum tip height: 41,1 m



Swingaway extension

9.45m-16.76m Telescoping boom extension includes 7.32m manual pull-out to 16.76m. Stows alongside base boom section.

Maximum tip height: 57,7 m



Boom elevation

One double acting hydraulic cylinder with integral holding valve.

Elevation from -10° to +80°



Load moment and anti-two block system

Graphical, LMI system with Audio-visual (light/buzzer) warning system and control lever lockout system with electronic display of boom angle and length, relative load moment indication, rated load, load, radius and boom tip height. The standard Work Area Definition System (WADS) allows the operator to pre-select and define safe working areas.



Cab

All steel construction with acoustical lining and tinted glass throughout, deluxe seat with armrest mounted single-axis hydraulic pilot controllers, windshield and sliding skylight with electric wipers, hot water cab heater with defroster which is diesel fired, circulating fan, fire extinguisher, dual cab mounted work lights. EET electronic throttles included. Unit is equipped with a signal horn switch and engine start/stop switches.



Slewing

360° continuous rotation, planetary “Glide swing” with foot actuated multi-disk brake, pinion guard.



Counterweight

Pinned to structure.

2495 kg.



Hydraulic system

Pressure compensated, load-sense, closed-center hydraulic system with (1) left-hand rotation, variable displacement piston pump; hydraulic reservoir, external sight level indicator, filter condition indicator; oil temperature indication and oil cooler with electric fan. Reservoir capacity 378l equipped with butterfly valve on the suction line to the pump.



Hoist

Main hoist with grooved drum, two-speed power up and down with automatic multi-disc brake, electronic drum rotation indicator (DRI) & Last Layer Indicator and drum cable follower. Bare drum pull 6,804 kg low speed.

Maximum permissible line pull:

5,103 kg with 7x35 class rope.

Planetary reduction with automatic spring applied multi-disc wet brake. Electronic hoist drum rotation indicators, and hoist drum cable followers.

Maximum single line pull:

1st layer: 5,280 kg

3rd layer: 4,323 kg

5th layer: 3,656 kg

Maximum permissible line pull:

5,280 kg with 6x37 class rope.

5,280 kg with 35x7 class rope.

Maximum single line speed: 136 m/min

Rope construction:

6X36 EIPS IWRC, Special Flexible

35x7 Flex-X, Rotation Resistant

Rope diameter: 16 mm

Rope length:

Main hoist: 137 m

Auxiliary hoist: 137 m

Maximum rope stowage: 181 m

Rope diameter: 16 mm

Rope length: 137 m

**Denotes optional equipment*

Specification

Superstructure continued

Hookblock

18t, 149 kg single sheave, "quick reeve" type block with swivel hook and safety latch. (Maximum capacity 15,300 kgs).



Outrigger system

Hydraulic front and rear. 2 section extendable beams with integral check valves for 360° operation; 607 mm diameter aluminum outrigger floats.

3 Position settings: 0%, 50% and 100%.

Controls located in crane cab and on both sides of subframe.

Unit has outrigger in motion alarm system.

Single front stabilizer - folds for tilting truck hood (requires extended front truck chassis frame rails).

*Optional equipment

- ▶ Air Conditioning in Cab
- ▶ Manual applied lock on rotation bearing (360° positioning)
- ▶ Swing away extension
- ▶ Auxiliary winch
- ▶ Four function remote control. (Will not function auxiliary winch option)

Carrier

Chassis

FM 340HP 8*4 Rigid High, B ride



Electrical system

Two 12V-maintenance free batteries.

24V electrical system with 24V starting and 24V lights.

Can-Bus diagnostic system.

Master battery disconnect for superstructure electrical system



Engine

Euro 3 Engine emission level

Euro 3 Engine emission control

Engine, 9 litre, 340 hp, 1600 Nm

Gearbox 9 speed, 2000 Nm

Fuel tank

114 l

Cab interior

Grey mirrors, insteps and bumper; sunvisor, smoke colour; manual locking, internal remote to passenger door; roof hatch; electrical window lift; rubber floor mats; driver seat, comf, susp; pass seat, regular; storage on engine tunnel and rear cab wall; climate unit manual air condition; engine block heater (220 volt, 1.5 kW); ambient temperature meter; cruise control, standard; dual dash outlets, 24V + 12V; black safety belts, pass. and driver seats; back up alarm; fire extinguisher, 2 kg, French decal; first aid kit and two warning triangles; one day tachograph, EC approved; speed limiter setting 90 km/h, EC; Jack, 20 tonnes; toolkit, complete; tyre inflation hose (20 metre); tire pressure gauge.

Cab exterior

Front steel bumper; insect net in front of radiator; manual cab tilt pump; mechanical cab suspension; halogen H7 head lamps; headlamp adjustment; head lamp asymmetric, left hand drive; two auxiliary front driving lamps; front fog lights white; three identification lamps on cab roof; switch in cab for identification lamps; one cab roof pass through, passenger side; CB radio antenna preparation kit; emblem mounted; signal Yellow.

Tyres

Steel rims

315/80R22.5 K CONT HSC1

315/80R22.5 L CONT HDW

Spare wheel&tyre equal to front wheel

*Auxiliary equipment

- ▶ Auxiliary lighting package (includes cab mounted amber flashing light, hoist mounted work light, and dual base boom mounted floodlights)
- ▶ LMI light bar (in cab)
- ▶ Air conditioning (28 500 BTU)
- ▶ 360° NYC style mechanical swing lock
- ▶ Rear Pintle hook
- ▶ Cab controlled cross axle differential locks, (front and rear)
- ▶ PAT data logger
- ▶ Rubber mat for storage trough

**Denotes optional equipment*

Specifications

GBT35 hookblock data

- All winch pulls and speeds are shown on the fourth layer.
- Winch line pulls would increase on the first, second, and third layers.
- Winch line speed would decrease on the first, second, and third layers.
- Winch line pulls may be limited by the winch capacity or the ANSI 5 to 1 cable safety factor.

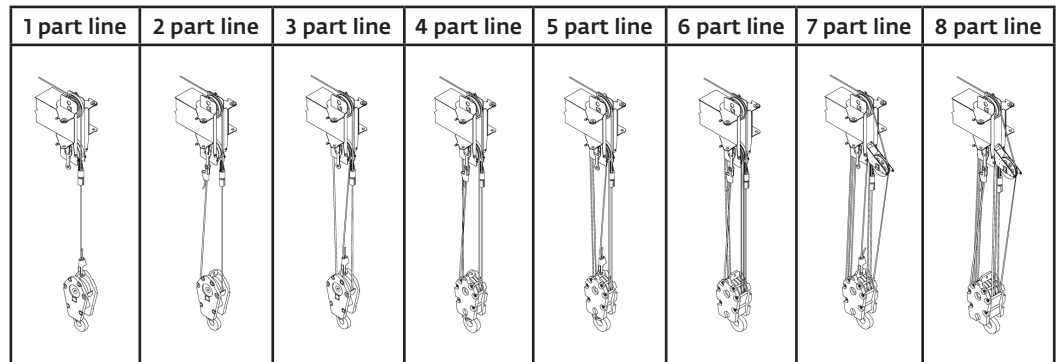

Standard planetary winch	Cable supplied	Average breaking strength	Max. pull	Max. pull	Max. pull	Max. pull	Max. pull	Max. pull	Max. pull	Max. pull
Low speed	16 mm diameter rotation resistant IWRC	25 583 kg	5103 kg 62 m/min	10 206 kg 31 m/min	15 309 kg 21 m/min	20 412 kg 16 m/min	25 515 kg 13 m/min	30 618 kg 10 m/min	35 721 kg 9 m/min	40 824 kg 8 m/min
High speed	16 mm diameter rotation resistant IWRC	25 583 kg	2268 kg 125 m/min	4536 kg 62 m/min	6804 kg 42 m/min	9072 kg 31 m/min	11 340 kg 25 m/min	13 608 kg 21 m/min	15 876 kg 18 m/min	18 144 kg 16 m/min

Winch	Fourth layer pull	Allowable cable pull
Standard planetary and auxiliary planetary	2268 kg high speed 5103 kg low speed	5117 kg 5117 kg

Loadline deduct		
	Aux boom head	45 kg
5,1 t	Downhaul weight	82 kg
15,3 t	1-sheave block	170 kg
25,5 t	2-sheave block	250 kg
35,7 t	3-sheave block	318 kg
40,8 t	4-sheave block	409 kg

Dimensions

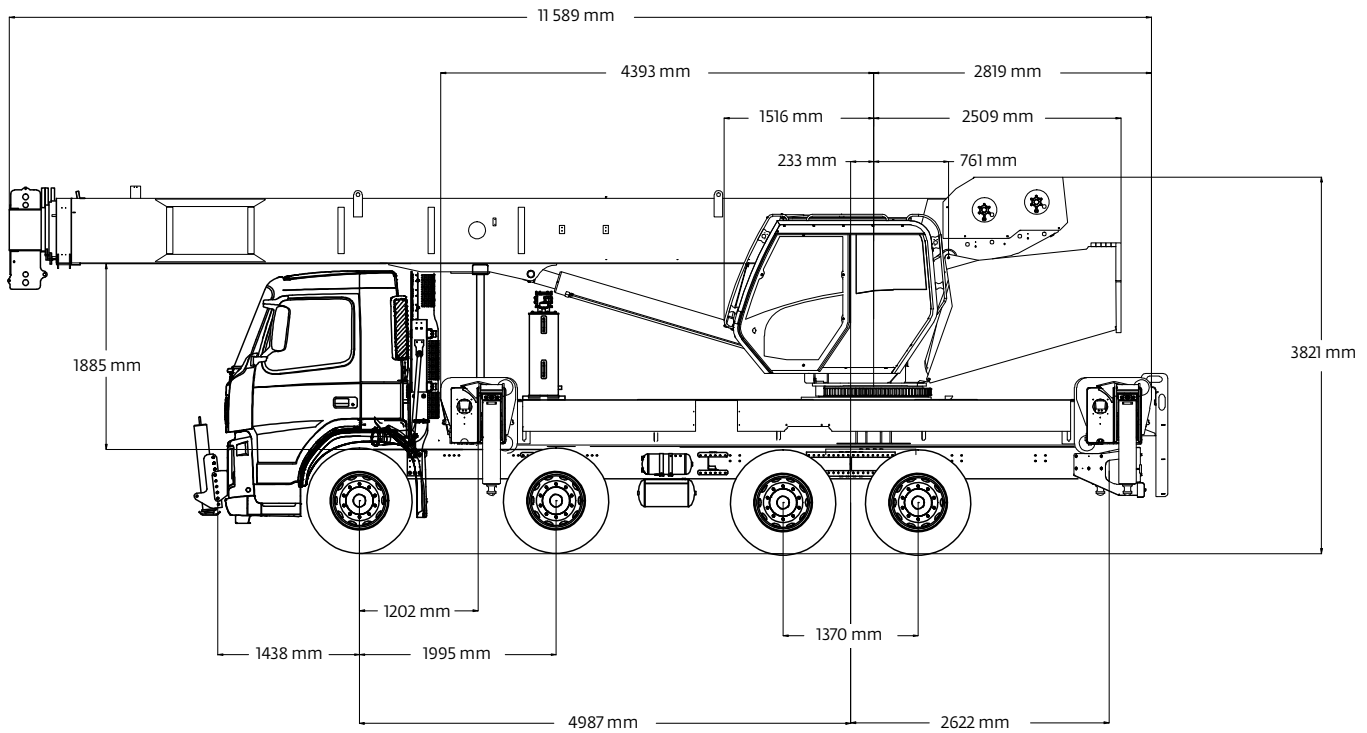

C/L Rotation

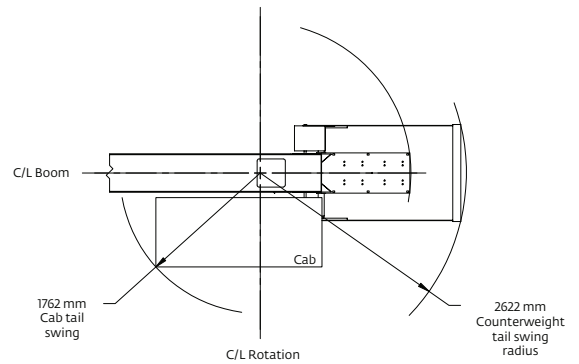
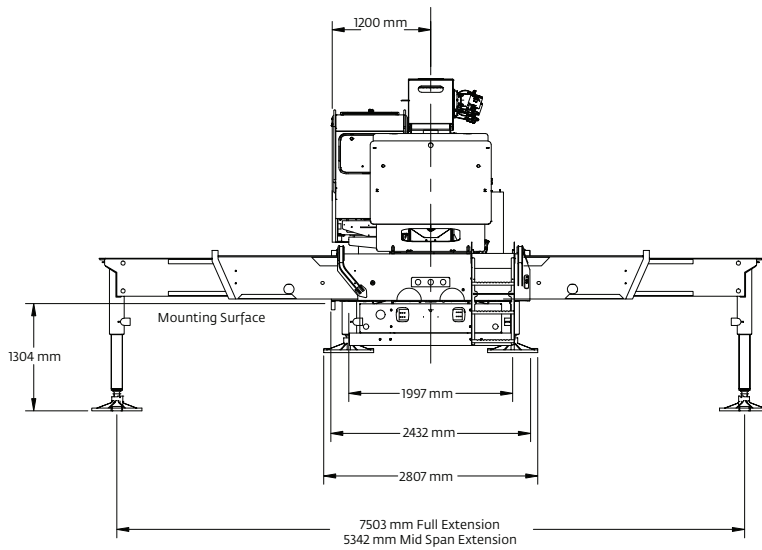

Weight/CG Data					
Series	Dimension G	Weight with oil	front axles	rear axles	GVW
GBT35127	50"	38,179 lb	13040 kg	16400 kg	29440 kg

No jib, no auxiliary hoist, with 2/3 hookblock.

Working range

38,71 m boom main boom with extension, outriggers fully extended

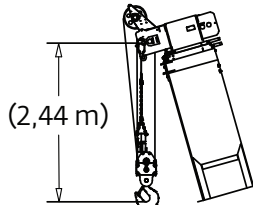
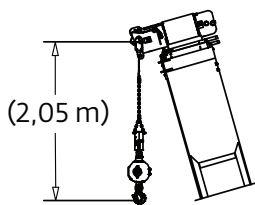
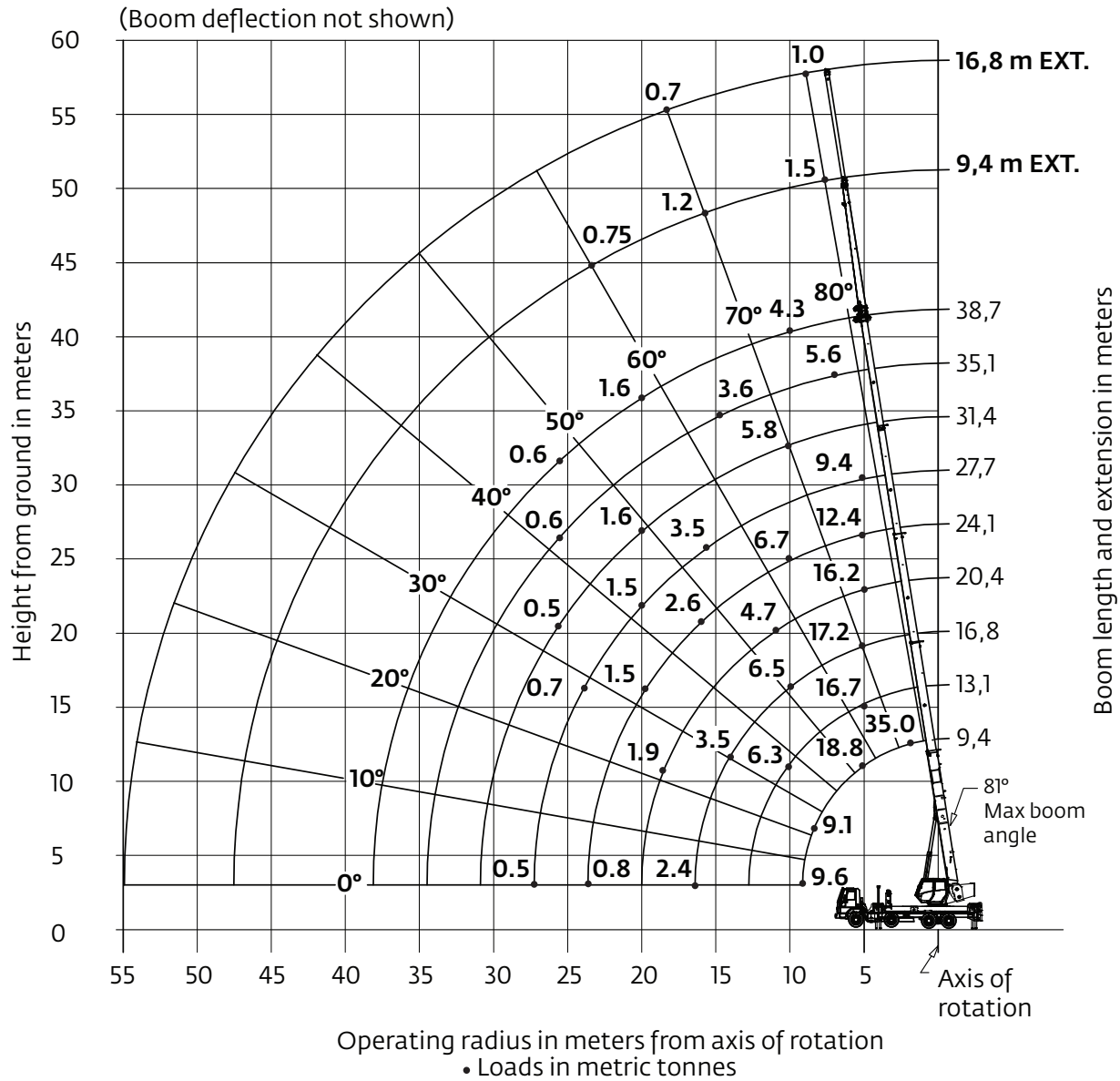

Dimensions are for largest furnished hook block and headache ball, with anti-two block activated.

*Drawing is to show the physical reach of the machine. Always refer to load chart to see what portions of this range are structurally and stability limited.

Load chart

38,71 m main boom, full span outriggers, 360°, without stowed extension

Radius in meters	#01								
	Main boom length in meters								
	9,4	13,1-A	16,8-B	20,4-C	24,1-D	27,7-E	31,4-F	35,1-G	38,7
2,5	35 000 (70,9)								
3	31 950 (67,7)								
3,5	27 500 (64,4)	18 550 (71,7)							
4	23 950 (61)	18 250 (69,4)	18 350 (74,1)	17 750 (77)					
4,5	20 950 (57,4)	17 750 (67,1)	18 350 (72,3)	17 000 (75,5)					
5	18 800 (53,7)	16 950 (64,6)	17 450 (70,5)	16 400 (74,1)	12 550 (76,5)	9550 (78,4)			
6	15 150 (45,7)	15 200 (59,7)	15 400 (66,8)	15 250 (71,1)	11 450 (74,1)	8850 (76,2)			
7	12 200 (36,3)	12 550 (54,4)	12 700 (63)	12 800 (68,1)	10 600 (71,6)	8200 (74,1)	7000 (76)	5750 (77,5)	
8	9500 (23,9)	9800 (48,8)	10 000 (59,1)	10 050 (65,1)	9800 (69,1)	7600 (71,9)	6600 (74,1)	5600 (75,8)	4500 (77,1)
9		7950 (42,6)	8100 (55)	8200 (61,9)	8250 (66,5)	7150 (69,7)	6250 (72,2)	5350 (74,1)	4450 (75,6)
10		6550 (35,5)	6700 (50,6)	6800 (58,7)	6850 (63,8)	6750 (67,5)	5900 (70,3)	5100 (72,4)	4350 (74,1)
12		4600 (13,9)	4800 (41)	4900 (51,8)	4950 (58,4)	4950 (62,9)	4950 (66,3)	4700 (68,9)	4100 (70,9)
14			3550 (28,9)	3600 (44,2)	3700 (52,6)	3700 (58,2)	3750 (62,3)	3750 (65,4)	3700 (67,8)
16			2600 (1,6)	2750 (35,3)	2800 (46,3)	2850 (53,2)	2850 (58)	2850 (61,7)	2850 (64,5)
18				2050 (23,7)	2150 (39,2)	2150 (47,8)	2200 (53,6)	2200 (57,9)	2200 (61,2)
20					1650 (30,8)	1650 (41,9)	1700 (48,9)	1700 (53,9)	1700 (57,7)
22					1200 (19,4)	1250 (35,2)	1250 (43,8)	1300 (49,8)	1300 (54,1)
24						900 (27,1)	950 (38,2)	950 (45,3)	950 (50,3)
26						650 (15,6)	650 (31,8)	700 (40,5)	700 (46,3)
Minimum boom angle (°) for indicated length (no load)								0	15
Maximum boom length (m) at 0° boom angle (no load)								35,1	

NOTE: () Boom angles are in degrees.

#LMI operating code. Refer to LMI manual for operating instructions.

Lifting capacities at zero degree boom angle									
Boom angle	Main boom length in meters								
	9,4	13,1-A	16,8-B	20,4-C	24,1-D	27,7-E			
0°	7950 (8,7)	4300 (12,3)	2600 (16)	1600 (19,7)	1000 (23,3)	500 (27)			

NOTE: () Reference radii in meters.

80028653

Rated Load Reductions from main boom capacity when lifting over main boom nose with ext. erected (retracted):									
(in kg)	1,045	975	910	885	865	840	820	795	775

Load chart

38,71 m main boom, full span outriggers, 360°, with stowed extension

Radius in meters	#02								
	Main boom length in meters								
	9,4	13,1-A	16,8-B	20,4-C	24,1-D	27,7-E	31,4-F	35,1-G	38,7
2,5	35 000 (70,9)								
3	31 585 (67,7)								
3,5	27 135 (64,4)	18 255 (71,7)							
4	23 585 (61)	17 955 (69,4)	18 145 (74,1)	17 565 (77)					
4,5	20 585 (57,4)	17 455 (67,1)	18 145 (72,3)	16 815 (75,5)					
5	18 435 (53,7)	16 655 (64,6)	17 245 (70,5)	16 215 (74,1)	12 365 (76,5)	9390 (78,4)			
6	14 785 (45,7)	14 905 (59,7)	15 195 (66,8)	15 065 (71,1)	11 265 (74,1)	8690 (76,2)			
7	11 835 (36,3)	12 255 (54,4)	12 495 (63)	12 615 (68,1)	10 415 (71,6)	8040 (74,1)	6860 (76)	5635 (77,5)	
8	9135 (23,9)	9 505 (48,8)	9795 (59,1)	9865 (65,1)	9615 (69,1)	7440 (71,9)	6460 (74,1)	5485 (75,8)	4405 (77,1)
9		7655 (42,6)	7895 (55)	8015 (61,9)	8065 (66,5)	6990 (69,7)	6110 (72,2)	5235 (74,1)	4355 (75,6)
10		6255 (35,5)	6495 (50,6)	6615 (58,7)	6665 (63,8)	6590 (67,5)	5760 (70,3)	4985 (72,4)	4255 (74,1)
12		4305 (13,9)	4595 (41)	4715 (51,8)	4765 (58,4)	4790 (62,9)	4810 (66,3)	4585 (68,9)	4005 (70,9)
14			3345 (28,9)	3415 (44,2)	3515 (52,6)	3540 (58,2)	3610 (62,3)	3635 (65,4)	3605 (67,8)
16			2395 (1,6)	2565 (35,3)	2615 (46,3)	2690 (53,2)	2710 (58)	2735 (61,7)	2755 (64,5)
18				1865 (23,7)	1965 (39,2)	1990 (47,8)	2060 (53,6)	2085 (57,9)	2105 (61,2)
20					1465 (30,8)	1490 (41,9)	1560 (48,9)	1585 (53,9)	1605 (57,7)
22					1015 (19,4)	1090 (35,2)	1110 (43,8)	1185 (49,8)	1205 (54,1)
24						740 (27,1)	810 (38,2)	835 (45,3)	855 (50,3)
26						490 (15,6)	510 (31,8)	585 (40,5)	605 (46,3)
Minimum boom angle (°) for indicated length (no load)								0	15
Maximum boom length (m) at 0° boom angle (no load)								35,1	

NOTE: () Boom angles are in degrees.

#LMI operating code. Refer to LMI manual for operating instructions.

Lifting capacities at zero degree boom angle									
Boom angle	Main boom length in meters								
	9,4	13,1-A	16,8-B	20,4-C	24,1-D	27,7-E			
0°	7585 (8,7)	4005 (12,3)	2395 (16)	1415 (19,7)	815 (23,3)	340 (27)			

NOTE: () Reference radii in meters.

80028658

Load chart

38,71 m main boom, full span outrigger, 360°, with telescopic jib

Radius in meters	9,4 m LENGTH
	#03
9,1	1525 (80)
14,0	1450 (75)
18,2	1200 (70)
22,2	950 (65)
25,9	750 (60)
29,2	525 (55)
32,3	275 (50)
Min. boom angle for indicated length (no load)	45°
Max. boom length at 0° boom angle (no load)	27,7 m

Radius in meters	16,8 m LENGTH
	#04
10,9	1000 (80)
16,4	1000 (75)
21,3	700 (70)
25,9	450 (65)
Min. boom angle for indicated length (no load)	50°
Max. boom length at 0° boom angle (no load)	24,1 m

80028722

NOTE: () Boom angles are in degrees.
#LMI operating code. Refer to LMI manual for operating instructions.

Boom extension capacity notes:

1. All capacities above the bold line are based on structural strength of boom extension.
2. 9,4 m and 16,8 m extension lengths may be used for single line lifting service
3. Radii listed are for a fully extended boom with the boom extension erected. For main boom lengths less than fully extended, the rated loads are determined by boom angle. For boom angles not shown, use the rating of the next lower angle.
Warning: Operation of this machine with heavier loads than the capacities listed is strictly prohibited. Machine tipping with boom extension occurs rapidly and without advance warning.
4. Boom angle is the angle above or below horizontal of the longitudinal axis of the boom base section after lifting rated load.
5. Capacities listed are with outriggers properly extended and vertical jacks set.
6. When lifting over the main boom nose with 9,4 m or 16,8 m extension erected, the outriggers must be fully extended or 50% extended.

Notes

Manitowoc Cranes

Regional headquarters

Americas

Manitowoc, Wisconsin, USA
Tel: +1 920 684 6621
Fax: +1 920 683 6277

Shady Grove, Pennsylvania, USA
Tel: +1 717 597 8121
Fax: +1 717 597 4062

Europe, Middle East, Africa

Ecully, France
Tel: +33 (0)4 72 18 20 20
Fax: +33 (0)4 72 18 20 00

China

Shanghai, China
Tel: +86 21 6457 0066
Fax: +86 21 6457 4955

Greater Asia-Pacific

Singapore
Tel: +65 6264 1188
Fax: +65 6862 4040

Regional offices

Americas

Brazil
Alphaville
Mexico
Monterrey
Chile
Santiago

Europe, Middle East, Africa

Czech Republic
Netvorice
France
Baudemont
Cergy
Decines
Germany
Langenfeld
Hungary
Budapest
Italy
Lainate
Netherlands
Breda
Poland
Warsaw
Portugal
Baltar
Russia
Moscow
U.A.E.
Dubai
U.K.
Buckingham

China

Beijing
Chengdu
Guangzhou
Xian

Greater Asia-Pacific

Australia
Adelaide
Brisbane
Melbourne
Sydney
India
Calcutta
Chennai
Delhi
Hyderabad
Pune
Korea
Seoul
Philippines
Makati City
Singapore

Factories

Brazil
Alphaville
China
TaiAn
Zhangjiagang
France
Charlieu
Moulins
Germany
Wilhelmshaven
India
Pune
Italy
Niella Tanaro
Portugal
Baltar
Fânzeres
Slovakia
Saris
USA
Manitowoc
Port Washington
Shady Grove

This document is non-contractual. Constant improvement and engineering progress make it necessary that we reserve the right to make specification, equipment, and price changes without notice. Illustrations shown may include optional equipment and accessories and may not include all standard equipment.